

Product Data Sheet 4414/2N-522

ebmpapst

Die Wahl der Ingenieure



4414/2N-522

INDEX

1	General	3
2	Mechanics	3
2.1	General	3
2.2	Connections	3
3	Operating Data	4
3.1	Operating Data - Electrical Interface - Input	4
3.2	Electrical Operating Data	5
3.3	Operating Data - Electrical Interface -Output	6
3.4	Electrical Features	7
3.5	Aerodynamic	8
3.6	Sound Data	9
4	Environment.....	9
4.1	General	9
4.2	Climatic requirements*)	9
5	Safety.....	10
5.1	Electrical Safety	10
5.2	Approval Tests	10
6	Reliability.....	10
6.1	General	10

1 General

Fan type	Fan	
Rotational direction looking at rotor	clockwise	
Airflow direction	Air outlet over struts	
Bearing system	Ball bearing	
Mounting position	any	

2 Mechanics

2.1 General

Width	119,0 mm	
Height	119,0 mm	
Depth	38,0 mm	
Weight	0,285 kg	
Housing material	Plastic	
Impeller material	Plastic	
Max. torque when mounted across both mounting flanges	wire outlet corner: 80 Ncm remaining corners: 80 Ncm	
Screw size	ISO 4762 - M4 degreased, without an additional brace and without washer	

2.2 Connections

Electrical connection	Wires	
Length of lead wire	L = 1.000 mm	
Tolerance	+/- 15,0 mm	
Wire gauge (AWG)	24	
Insulation diameter	1,10 mm	
Contact	see drawing	

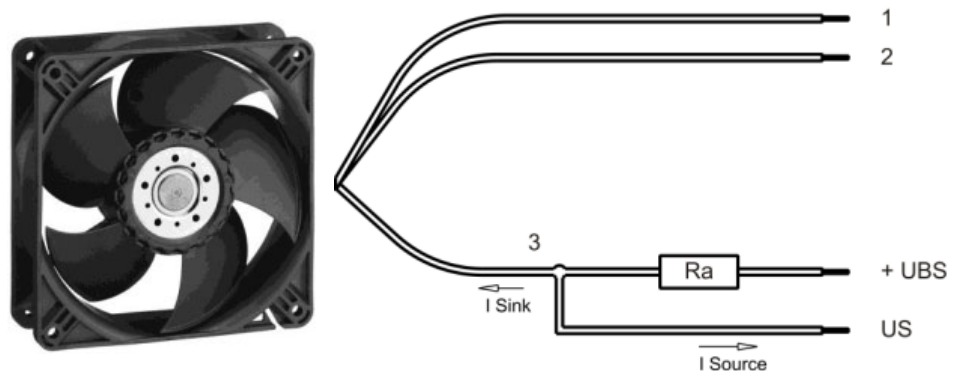

	Colour	Operation
Wire 1	red	+ UB
Wire 2	blue	- GND
Wire 3	white	Tacho

The auxiliaries shown on the schematic diagram (which are required for the intended use) are not part of our delivery.

3 Operating Data

3.1 Operating Data - Electrical Interface - Input

Control input	None
---------------	------

3.2 Electrical Operating Data

Measurement conditions: Normal air density = 1,2 kg/m³; Temperature 23°C +/- 3°C; Motor axis horizontal; warm-up time before measuring 5 minutes (unless otherwise specified). In the intake and outlet area should not be any solid obstruction within 0,5 m.

$\Delta p = 0$: corresp. to free air flow (see section 3.5)
 I: corresp. to arithm. mean current value

Features	Condition	Symbol	Values		
Voltage range	$\Delta p = 0$	U	18,0 V		28,0 V
Nominal voltage	$\Delta p = 0$	U_N		24,0 V	
Power consumption	$\Delta p = 0$	P	2,8 W	5,4 W	7,8 W
Tolerance	0001		+/- 17,5 %	+/- 12,5 %	+/- 15,0 %
Current consumption	$\Delta p = 0$	I	157 mA	226 mA	280 mA
Tolerance	0001		+/- 17,5 %	+/- 12,5 %	+/- 15,0 %
Speed	$\Delta p = 0$	n	2.870 1/min	3.650 1/min	4.070 1/min
Tolerance	0001		+/- 12,5 %	+/- 7,5 %	+/- 10,0 %
Starting current consumption				< 1.850 mA	

3.3 Operating Data - Electrical Interface -Output

Tacho type	/2 (Open collector)
------------	---------------------

Signal-Ausgangsspannung / Signal output voltage

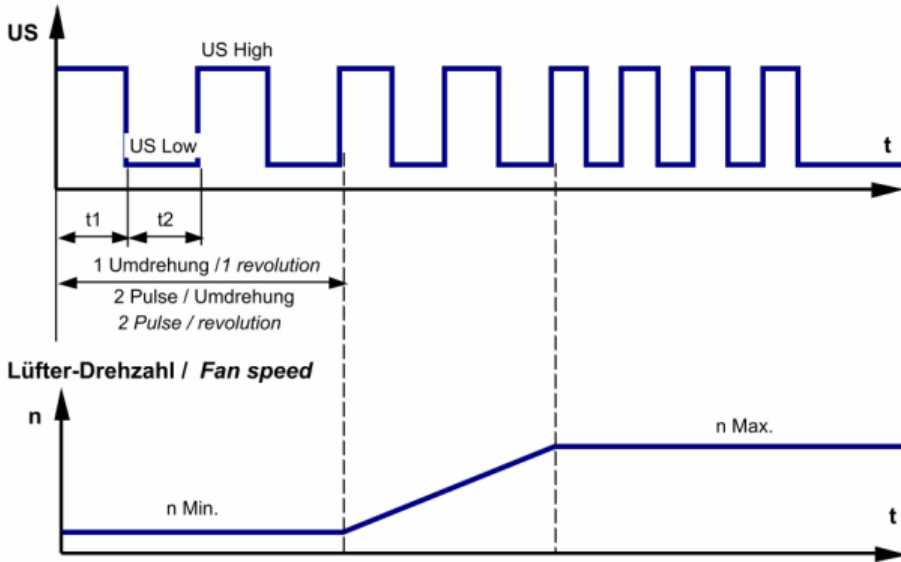

$$R_a = \frac{U_{BS} - US_{Low}}{I_{Sink}}$$

Features	Note	Values
Tacho operating voltage (UBS)		30 V
Tacho signal Low	I sink: 2 mA	<= 0,4 V
Tacho signal High	I source: 0 mA	30 V
Maximum sink current		<= 4 mA
External resistor	External resistor Ra from UBS to US required. All voltages measured to GND.	
Tacho frequency	(2 x n) / 60	
Tacho isolated from motor	No	
Slew rate		=> 0,5 V/us

Alarm type	None
------------	------

3.4 Electrical Features

Electronic function	None	
Reversed polarity protection	Rectifying diode	
Max. residual current at U_n	$I_F \leq 50 \mu A$	
Locked rotor protection	Auto restart	
Locked rotor current at U_n	approx. 1.850 mA	
Clock signal t_3/t_4 at locked rotor	Typical: 0,5 s / 2,8 s	

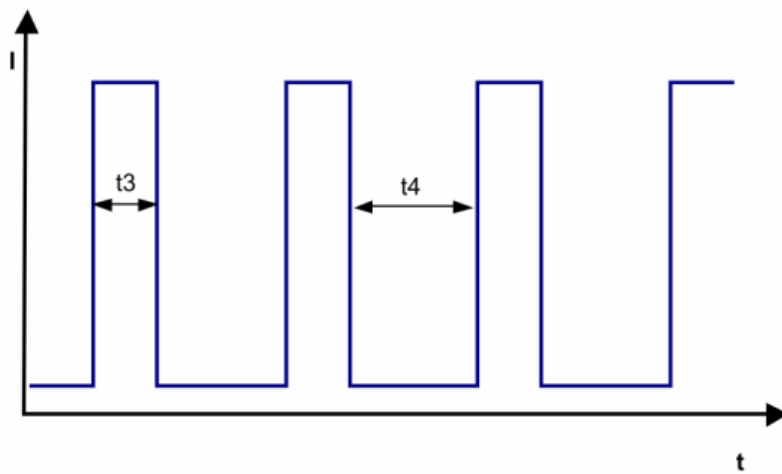

3.5 Aerodynamic

Measurement conditions: Measured with a double chamber intake rig acc. to DIN EN ISO 5801.
 Normal air density = 1,2 kg/m³; Temperature 23°C +/- 3°C;
 In the intake and outlet area should not be any solid obstruction within 0,5 m.
 The information is only valid under the specified test conditions and may be changed by the installation conditions. If there are deviations from the standard test conditions, the characteristic values must be checked under the installed conditions.

a.) Operation condition:

3.650 1/min at free air flow

Max. free-air flow ($\Delta p = 0 / \dot{V} = \text{max.}$)	205,0 m ³ /h	
Max. static pressure ($\Delta p = \text{max.} / \dot{V} = 0$)	118 Pa	

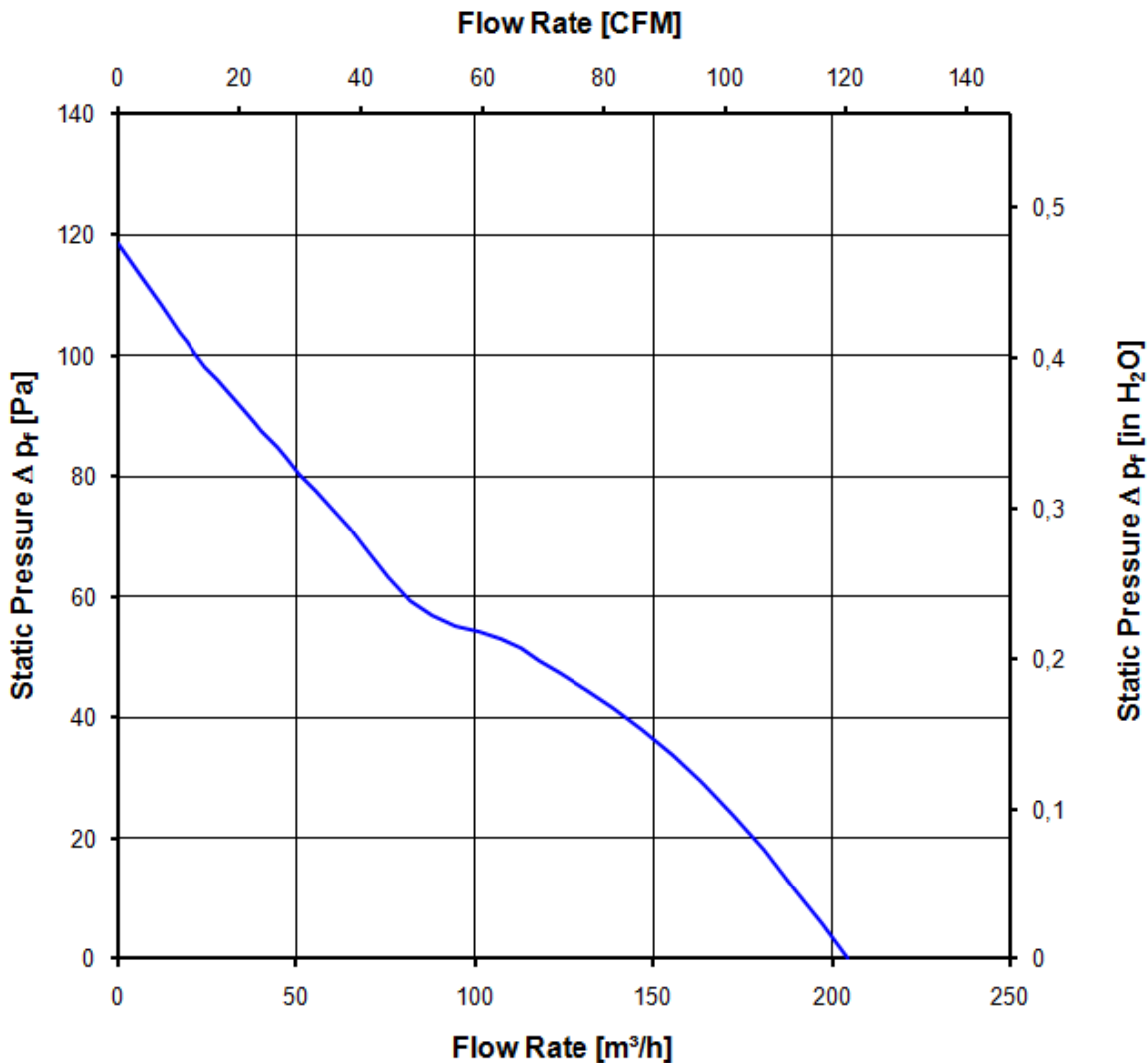

3.6 Sound Data

Measurement conditions: Sound pressure level: 1 Meter distance between microphone and the air intake.
 Sound power level: Acc. to DIN 45635 part 38 (ISO 10302)
 Measured in a semianchoic chamber with a background noise level of $L_p(A) < 5 \text{ dB(A)}$
 For further measurement conditions see section 3.5

a.) Operation condition:

3.650 1/min at free air flow

Optimal operating point	125,0 m ³ /h @ 42 Pa	
Sound power level at the optimal operating point	5,6 bel(A)	
Sound pressure level at free air flow, measured in rubber bands	46,0 dB(A)	

4 Environment

4.1 General

Min. permitted ambient temperature TU min.	-30 °C	
Max. permitted ambient temperature TU max.	75 °C	
Min. permitted storage temperature TL min.	-40 °C	
Max. permitted storage temperature TL max.	80 °C	

4.2 Climatic requirements*)

Humidity requirements	humid heat, constant; according to DIN EN 60068-2-78, 14 days	
Water exposure	None	
Dust requirements	None	
Salt fog requirements	None	

*) Permitted application area:

The product is intended for use in sheltered rooms with controlled temperature and controlled humidity. Directly exposure to water must be avoided.

Pollution degree 1 (according DIN EN 60664-1)

There is either no pollution or it occurs only dry, non-conductive pollution. The pollution has no negative impact. Please require severity levels and specification parameters from the responsible development departments

5 Safety

5.1 Electrical Safety

Dielectric strength DIN EN 60950 (VDE 0805) and DIN EN 60335 (VDE 0700) A.) Type test Measuring conditions: After 48h of storage at 95% R.H. and 25°C. No arcing or breakdown is allowed! All connections together to ground.	500 VAC / 1 Min.	
B.) Routine test Measuring conditions: At indoor climate. No arcing or breakdown is allowed! All connections together to ground.	500 VAC / 1 Sec.	
Isolation resistance Measuring conditions: After 48h of storage at 95% R.H. and 25°C measured with U=500 VDC for 1 min.	RI > 10 MOhm	
clearance / creepage distance	1,0 mm / 1,2 mm	
Protection class	III	

5.2 Approval Tests

CE	EC Declaration of Conformity	Yes
EAC	Eurasian Conformity	Yes
UL	Underwriters Laboratories	Yes / UL507, Electric Fans
VDE	Association for Electrical, Electronic and Information Technologies	Yes / Approval acc. to EN 60950 (VDE 0805) - Information technology equipment
CSA	Canadian Standards Association	Yes / C22.2 No. 113 Fans and Ventilators
CCC	China Compulsory Certification	No

The approval tests are observed to:

U approval max.: 28,0 V @ TU approval max.: 70,0 °C

6 Reliability

6.1 General



Life expectancy L10 at TU = 40 °C	62.500 h	
Life expectancy L10 Delta (40 °C)	120.000 h	

Handling of this document, and particularly its contents, shall be the sole responsibility of the customer. However, the customer shall be responsible for the accuracy of the data and the technical specifications. All rights are reserved. In the event of a dispute, the responsibility of a liability shall be assigned.

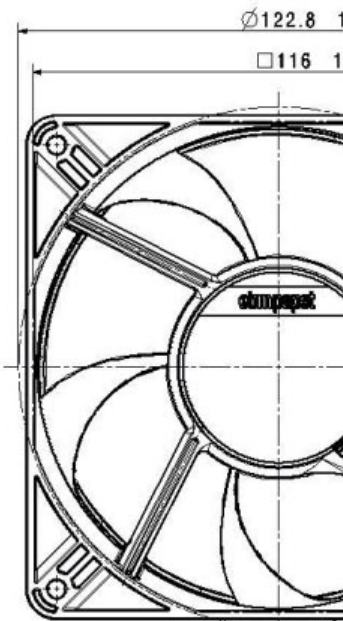
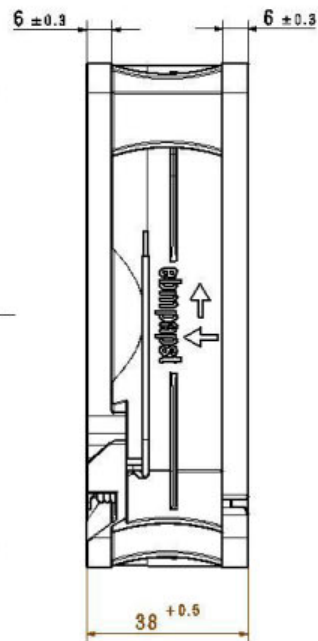
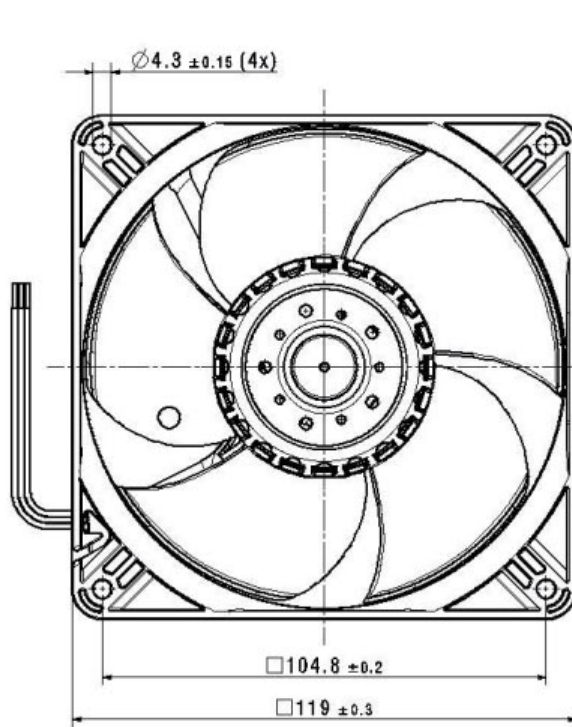
Handgezeichnet nach DIN 276 nach Maßstab 1:1
 Nach der Produktion prüfen nach DIN 276/1



- 1.) Maße fuer Montageausschnitt
- max. Anziehdrehmoment = 0.8Nm
 - Axialspiel: mit Feder spielfrei verspannt
 - Anzahl und Länge der Litzen siehe BV- Bl. 1
- 1.) measures for mounting cut-out
- max. tightening torque = 0.8Nm
 - without axial clearance by a pre-loaded spring
 - length and number of wires see design specification page 1

VP-Name/Part	Verf.-Nr./ Drawing No.	Größe/Größe-Typ/Größe/ Size/Size-Var./Size	Gr. Änderung/ Gr. Document	Skizzen / Bilder
	Datum		Name	
	Zeichner / Dessiner	Gepr. / Appr.		
Toleranzang. / Tolerances:		Zugl. - Nr. / Invenc.		
Allgemeintoleranz / Gen. Tolerances:		 ebm-papst st. georgien 60481 A CO KG		
		Arbeitsart / Type of Document:		

X-ON Electronics

Largest Supplier of Electrical and Electronic Components

Click to view similar products for [DC Fans](#) category:

Click to view products by [ebm papst](#) manufacturer:

Other Similar products are found below :

[614R](#) [AUB0612L](#) [AFB0948HH-S687](#) [G2E085-AA05-10](#) [4318/12T](#) [AUB0912H-F00](#) [3412N/2ME](#) [W2G110-AM39-01](#) [8412GLV](#) [8412NGL-12](#) [6448-384](#) [4114N/17-251](#) [622/2N](#) [4318/2R](#) [4412F/2D](#) [424JMU](#) [4414/2HH](#) [4112 N/12GL-175](#) [9GA0912F402](#) [9GA0812B20011](#) [AFB0824SHBAV1](#) [DV5214/2NP-230](#) [9GA0912H4021](#) [THC1548MGDJJ](#) [GFB1224SHG](#) [8500NU](#) [DC0401012V2B-3T0](#) [3254J/2HPU](#) [9A0612G402](#) [AD5012HB-C71](#) [AD5012MB-C71](#) [EF92251S3-1000U-A99](#) [PF80251B3-000U-Q99](#) [026758A](#) [3258J/2H3PU????](#) [412/2H](#) [4292](#) [MF60152V1-1000U-G99](#) [3610KL-04W-B50-D00](#) [EE92251B1-000U-G99](#) [8218J/2H4P](#) [4318NN](#) [4318NH3](#) [4314NL](#) [4312NM](#) [MITX-CORE-HTSNK](#) [ME45101V1-000U-A99](#) [OD1238-24HBIP55](#) [4312NHH](#) [612N/2GH](#)