

Max. 340 m³/h

DC axial fans

□ 127 x 38 mm



- **Material:** Housing: GRP¹⁾ (PBT)
Impeller: GRP¹⁾ (PA)
- **Direction of air flow:** Exhaust over struts
- **Direction of rotation:** Counterclockwise, looking towards rotor
- **Connection:** Via single wires AWG 22, TR 64
- **Weight:** 310 g

- **Possible special versions:**
(See chapter DC fans - specials)
 - Speed signal
 - Go / NoGo alarm
 - Alarm with speed limit
 - External temperature sensor
 - Internal temperature sensor
 - PWM control input
 - Analog control input
 - Moisture protection
 - Salt spray protection
 - Degree of protection: IP 54 / IP 68

1) Fiberglass-reinforced plastic

Series 5200 N														
Nominal data	Air flow		Nominal voltage	Voltage range	Sound pressure level	Sound power level	Sinter sleeve bearings Ball bearings	Power consumption**	Nominal speed	Temperature range	Service life L ₁₀ (40 °C) ebm-papst standard	Service life L ₁₀ (T _{max}) ebm-papst standard	Life expectancy L ₁₀ IPC (40 °C) see page 17	Curve
	m ³ /h	cfm												
5212 NM	187	110	12	7...14.5	43	5.3	■	4.1	2 750	-20...+75	62 500 / 27 500	105 000	①	
5212 NN	216	127	12	7...14	46	5.6	■	6.2	3 150	-20...+70	57 500 / 25 000	97 500	②	
5212 NH	252	148	12	7...14	51	6.0	■	9.8	3 650	-20...+70	45 000 / 22 500	75 000	③	
5212 NHH*	340	200	12	9...15	58	6.6	■	19.0	4 900	-20...+65	45 000 / 25 000	75 000	④	
5214 NM	187	110	24	12...28	43	5.3	■	4.6	2 750	-20...+75	62 500 / 27 500	105 000	①	
5214 NN	216	127	24	12...28	46	5.6	■	6.0	3 150	-20...+75	57 500 / 25 000	97 500	②	
5214 NH	252	148	24	12...28	51	6.0	■	9.8	3 650	-20...+70	45 000 / 22 500	75 000	③	
5214 NHH*	340	200	24	16...30	58	6.6	■	17.5	4 900	-20...+65	45 000 / 25 000	75 000	④	
5218 NM	187	110	48	36...56	43	5.3	■	4.5	2 750	-20...+75	62 500 / 27 500	105 000	①	
5218 NN	216	127	48	36...56	46	5.6	■	6.2	3 150	-20...+70	57 500 / 32 500	97 500	②	
5218 NH	252	148	48	36...56	51	6.0	■	9.6	3 650	-20...+55	45 000 / 32 500	75 000	③	
5218 NHH*	340	200	48	36...60	58	6.6	■	18.0	4 900	-20...+65	45 000 / 25 000	75 000	④	

Subject to change

** Power consumption at free air flow, these values can be significantly higher in the operating point.

*NHH models: fan housing with molded-in spacers.

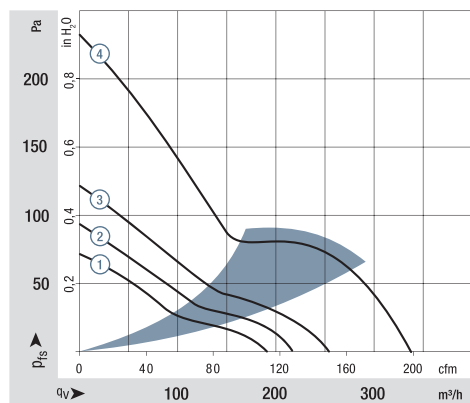
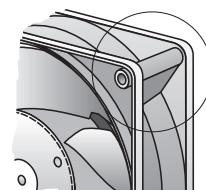

Air performance measured according to: ISO 5801. Installation category A, without contact protection. Noise: Total sound power level L_{WA} ISO 103002 measured on a hemisphere with a radius of 2 m. Sound pressure level L_{PA} measured at 1 m distance from fan axis. The values given are applicable only under the specified measuring conditions and may differ depending on the installation conditions. In the event of deviation from the standard configuration, the parameters must be checked after installation! For detailed information see <http://www.ebmpapst.com/general conditions>

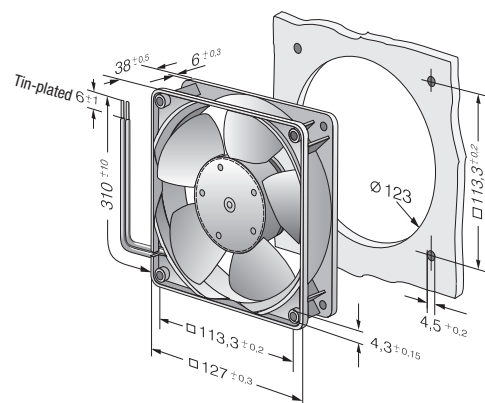

X-ON Electronics

Largest Supplier of Electrical and Electronic Components

Click to view similar products for [DC Fans](#) category:

Click to view products by [ebm papst](#) manufacturer:

Other Similar products are found below :

[614R](#) [AUB0612L](#) [AFB0948HH-S687](#) [G2E085-AA05-10](#) [4318/12T](#) [AUB0912H-F00](#) [3412N/2ME](#) [W2G110-AM39-01](#) [8412GLV](#) [8412NGL-12](#) [6448-384](#) [4114N/17-251](#) [622/2N](#) [4318/2R](#) [4412F/2D](#) [424JMU](#) [4414/2HH](#) [4112 N/12GL-175](#) [9GA0912F402](#) [9GA0812B20011](#) [AFB0824SHBAV1](#) [DV5214/2NP-230](#) [9GA0912H4021](#) [THC1548MGDJJ](#) [GFB1224SHG](#) [8500NU](#) [DC0401012V2B-3T0](#) [3254J/2HPU](#) [9A0612G402](#) [AD5012HB-C71](#) [AD5012MB-C71](#) [EF92251S3-1000U-A99](#) [PF80251B3-000U-Q99](#) [026758A](#) [3258J/2H3PU????](#) [412/2H](#) [4292](#) [MF60152V1-1000U-G99](#) [3610KL-04W-B50-D00](#) [EE92251B1-000U-G99](#) [8218J/2H4P](#) [4318NN](#) [4318NH3](#) [4314NL](#) [4312NM](#) [MITX-CORE-HTSNK](#) [ME45101V1-000U-A99](#) [OD1238-24HBIP55](#) [4312NHH](#) [612N/2GH](#)