

Product Data Sheet 6314 N/2TDHHP

**ebmpapst**

The engineer's choice



**6314 N/2TDHHP**

**INDEX**

<b>1</b>	<b>General .....</b>	<b>3</b>
<b>2</b>	<b>Mechanics .....</b>	<b>3</b>
2.1	General .....	3
2.2	Connections .....	3
<b>3</b>	<b>Operating Data .....</b>	<b>5</b>
3.1	Electrical Interface - Input .....	5
3.2	Electrical Operating Data .....	6
3.3	Electrical Interface - Output .....	7
3.4	Electrical Features .....	8
3.5	Data According ErP Directive .....	8
3.6	Aerodynamics .....	9
3.7	Sound Data .....	11
<b>4</b>	<b>Environment.....</b>	<b>11</b>
4.1	General .....	11
4.2	Climatic Requirements.....	11
4.3	Mechanical Requirements .....	11
<b>5</b>	<b>Safety.....</b>	<b>14</b>
5.1	Electrical Safety .....	14
5.2	Approval Tests .....	14
<b>6</b>	<b>Reliability.....</b>	<b>14</b>
6.1	General .....	14

**1 General**

Fan type	Fan	
Rotating direction looking at rotor	Counterclockwise	
Airflow direction	Air outlet over struts	
Bearing system	Ball bearing	
Mounting position - shaft	Any	

**2 Mechanics****2.1 General**

Depth	51,0 mm	
Diameter	172,0 mm	
Mass	0,875 kg	
Housing material	Metal	
Impeller material	Plastic	
Max. torque when mounted across both mounting flanges Screw size	Wire outlet corner: 440 Ncm Remaining corners: 440 Ncm ISO 4762 - M4 degreased, without an additional brace and without washer	

**2.2 Connections**

Electrical connection	Wires	
Lead wire length	L = 365 mm	
Tolerance	+ - 10,0 mm	
Tube length	S = 10 mm	
Tolerance	+ - 5,0 mm	
Wire size (AWG)	18 22	
Insulation diameter	1,7 mm 2,2 mm	

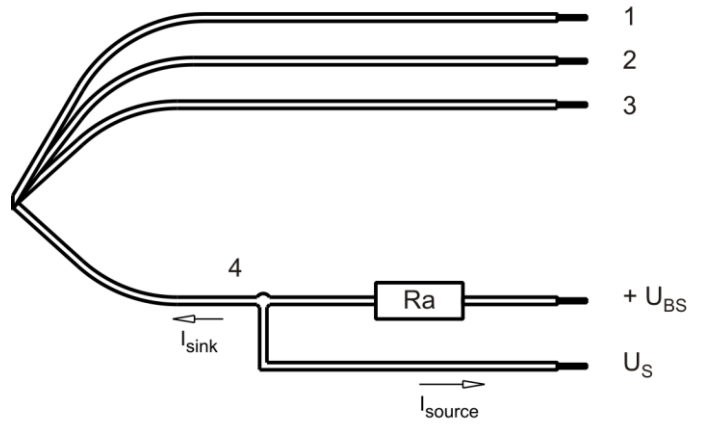

Wire	Color	Operation
1	red	+ UB
2	blue	- GND
3	violet	PWM
4	white	Tacho

The auxiliaries shown on the schematic diagram (which are required for the intended use) are not part of our delivery.

Lead wire 1 - 2: AWG18 (Insulation diameter 2,2 mm)  
 Lead wire 3 - 4: AWG22 (Insulation diameter 1,70 mm)

### 3 Operating Data

#### 3.1 Electrical Interface - Input

Control input	PWM
---------------	-----

#### Features

Input type	Open collector	
PWM - Frequency		1 kHz - 20 kHz typical: 2 kHz

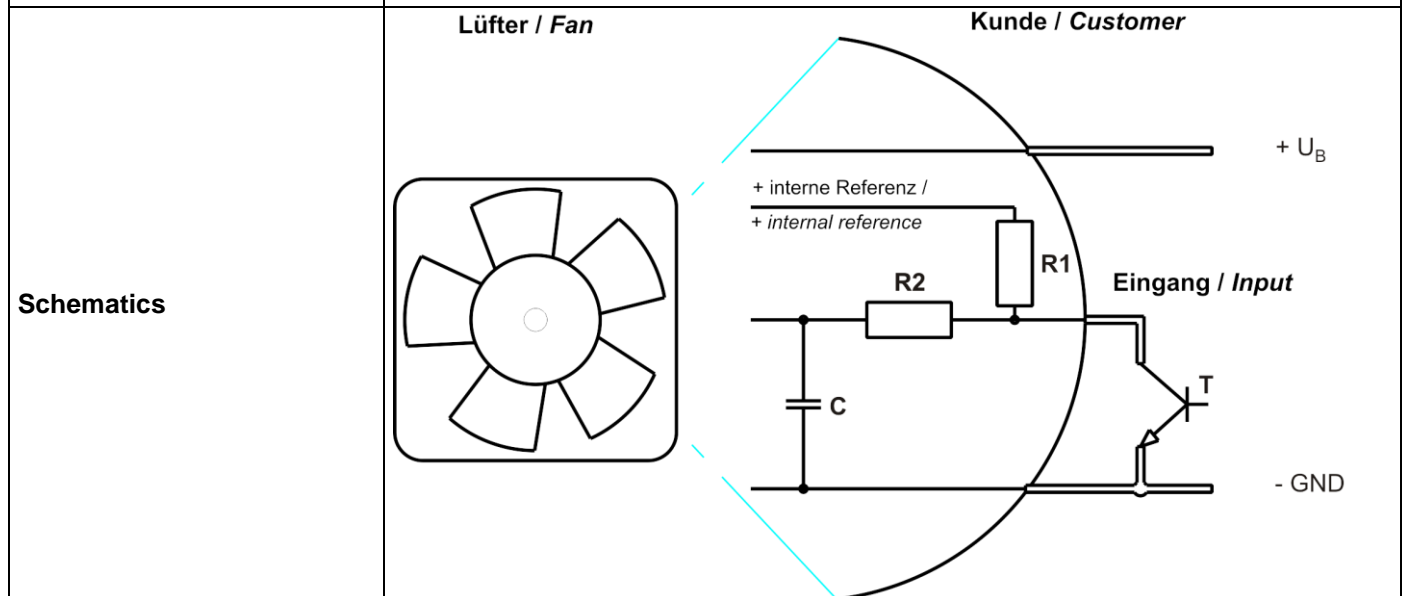
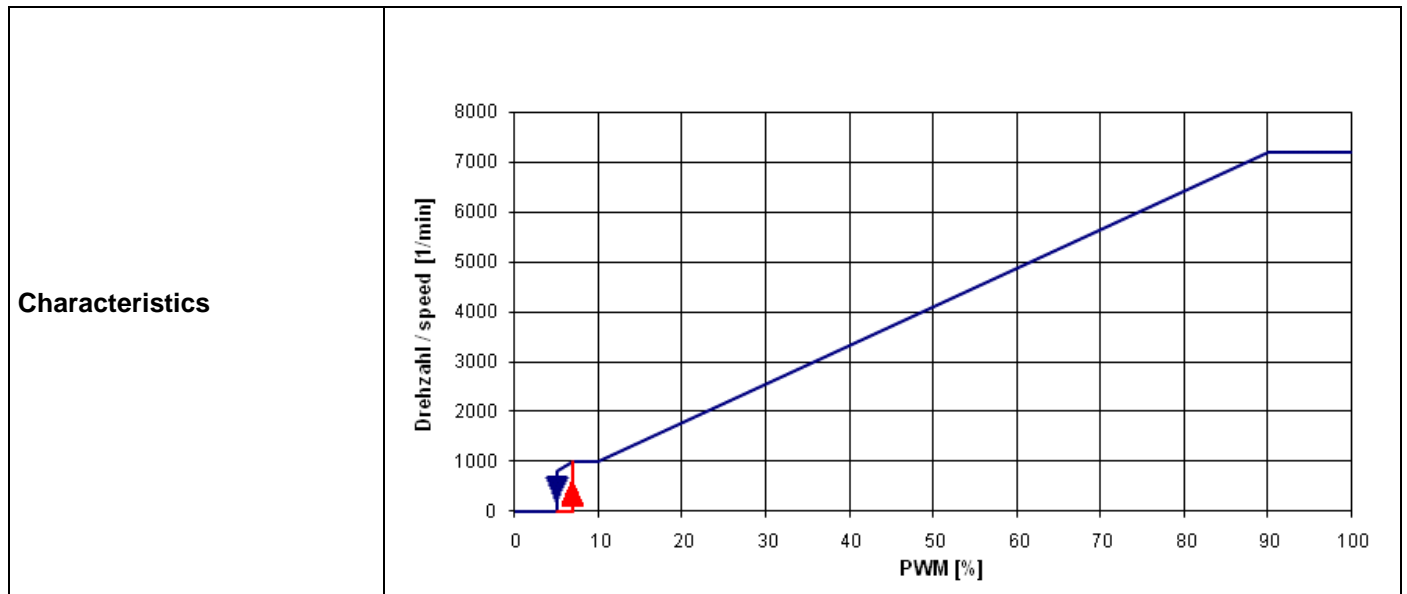

The shown pull-up resistor to the internal reference voltage (+5V) has 4.7kOhm.

### 3.2 Electrical Operating Data

Measurement conditions: Normal air density = 1,2 kg/m<sup>3</sup>; Temperature 23°C +/- 3°C; Motor axis horizontal; warm-up time before measuring 5 minutes (unless otherwise specified). In the intake and outlet area should not be any solid obstruction within 0,5 m.

$\Delta p = 0$ : corresp. to free air flow (see section 3.5)  
 I: corresp. to arithm. mean current value

Name	Condition
PWM 0001	PWM: 95 %; f: 2 kHz

>90% PWM; f = 2 kHz or broken lead wire (open control input)

Features	Condition	Symbol	Values		
Voltage range		U	16 V		36,0 V
Nominal voltage		U <sub>N</sub>		24,0 V	
Power consumption	$\Delta p = 0$	P	69 W	156 W	158 W
Tolerance	PWM 0010		+/- 10 %	+/- 10 %	+/- 10 %
Current consumption	$\Delta p = 0$	I	4.300 mA	6.500 mA	4.400 mA
Tolerance	PWM 0010		+/- 10 %	+/- 10 %	+/- 10 %
Speed	$\Delta p = 0$	n	5.600 1/min	7.200 1/min	7.200 1/min
Tolerance	PWM 0010		+/- 5 %	+/- 2 %	+/- 2 %

3.3 Electrical Interface - Output

Tacho type	/2 (open collector)
------------	---------------------

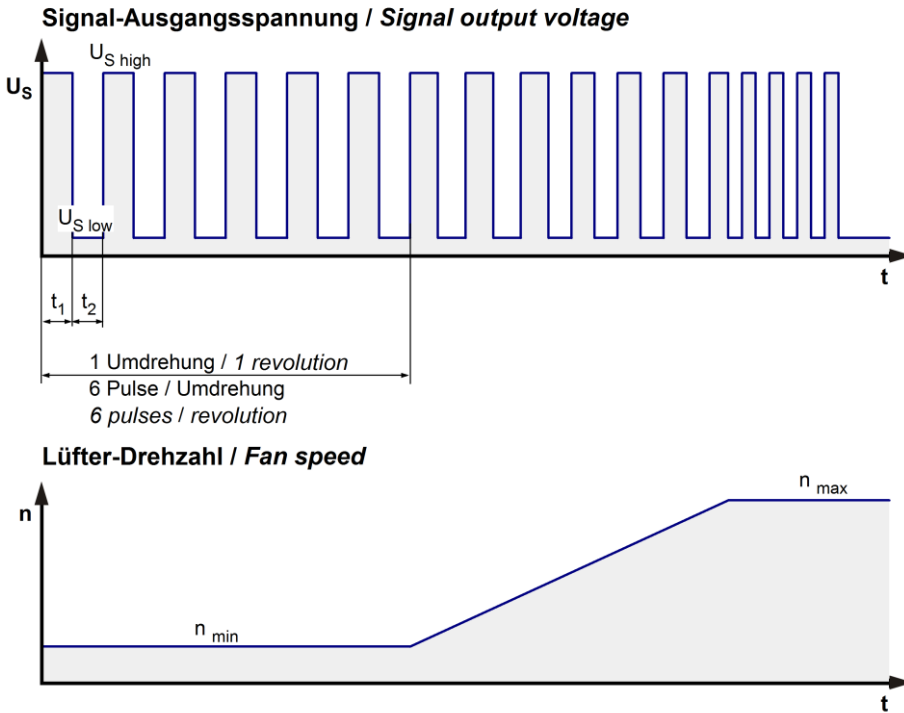

$$R_a = \frac{U_{BS} - U_{S\ low}}{I_{sink}}$$

Lüfter / Fan      Kunde / Customer

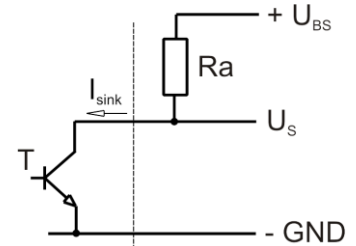

Features	Note	Values
Tacho operating voltage	$U_{BS}$	$\leq 32\text{ V}$
Tacho signal Low	$U_{S\ low}$	$\leq 0,4\text{ V}$
Tacho signal High	$U_{S\ high}$	$32\text{ V}$
Maximum sink current	$I_{sink}$	$\leq 20\text{ mA}$
External resistor	External resistor $R_a$ from $U_{BS}$ to $U_S$ required. All voltages measured to GND.	
Tacho frequency	$(6 \times n) / 60$	$720\text{ Hz}$
Tacho isolated from motor	No	
Slew rate		$\Rightarrow 0,5\text{ V/us}$

n = revolutions per minute (1/min)

### 3.4 Electrical Features

Electronic function	Speed-Controlled	
Reversed polarity protection	P-CH FET	
Max. residual current at $U_N$	$I_F \leq 5 \text{ mA}$	
Locked rotor protection	Auto restart	
Locked rotor current at $U_N$	$I_{\text{block}}$ approx. 2.000 mA	
Clock signal at locked rotor	$t_3 / t_4$ typical: 5 s / 10 s	

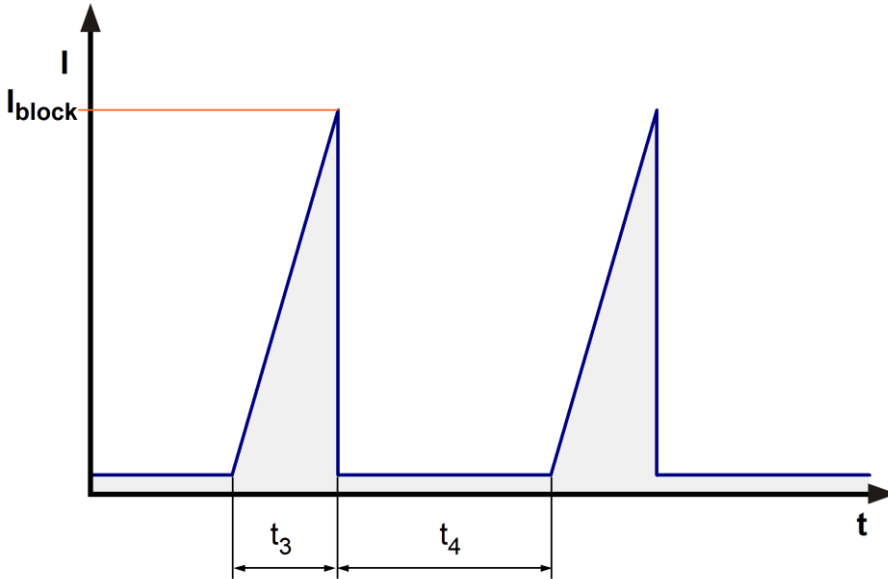

This fan has a startup delay of 2 seconds after applying supply voltage.

Internal Fuse: Littelfuse Nano2 Fuse Very Fast-Acting 451/453 Series 12A / 65V

### 3.5 Data According ErP Directive

Installation / Efficiency category	A / static
Speed control	integrated
Specific ratio	1,00422
Target overall efficiency 2015	29,1 %
Overall efficiency	46,7 %
Efficiency grade	40
Power input	186 W
Speed	7.200 1/min

All values measured in optimum energy efficiency point.

Productiondatecode is printed on the fan label.



### 3.6 Aerodynamics

Measurement conditions:

Measured with a double chamber intake rig acc. to DIN EN ISO 5801.  
 Normal air density = 1,2 kg/m<sup>3</sup>; Temperature 23°C +/- 3°C;  
 In the intake and outlet area should not be any solid obstruction within 0,5 m.  
 The information is only valid under the specified test conditions and may be changed by the installation conditions. If there are deviations from the standard test conditions, the characteristic values must be checked under the installed conditions. Power consumption of the fan motor when operating at normal voltage is shown. Depending on the operating conditions of the application, the power input may be higher.

a.) Operation condition:

7.200 1/min at free air flow	PWM 95 %; f: 2 kHz		
------------------------------	--------------------	--	--

Max. free-air flow ( $\Delta p = 0 / \dot{V} = \text{max.}$ )	992,0 m <sup>3</sup> /h	
Max. static pressure ( $\Delta p = \text{max.} / \dot{V} = 0$ )	1.005 Pa	

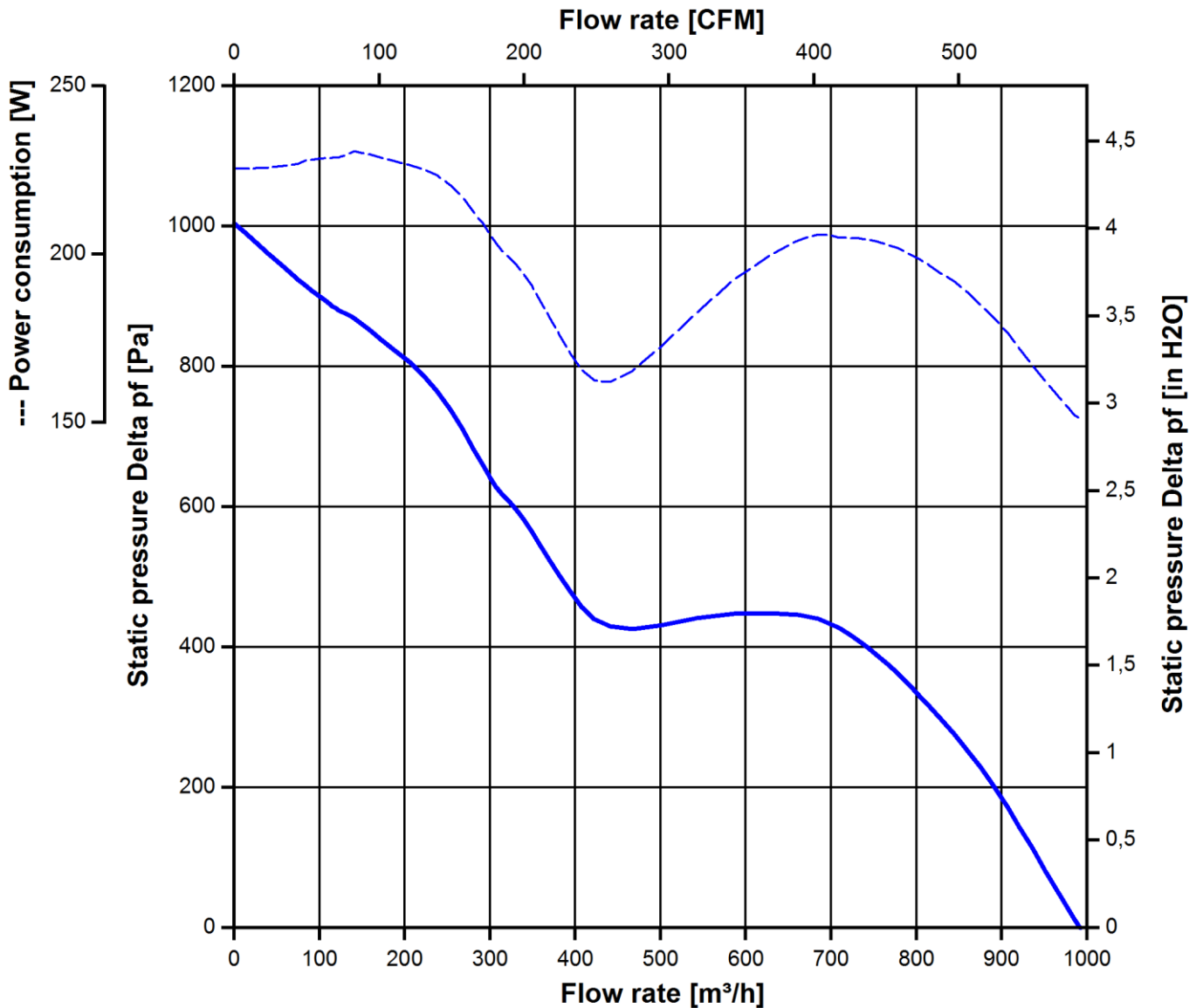



**3.7 Sound Data**

Measurement conditions: Sound pressure level: 1 meter distance between microphone and the air intake.  
 Sound power level: Acc. to DIN 45635 part 38 (ISO 10302)  
 Measured in a semianchoic chamber with a background noise level of  $L_p(A) < 5 \text{ dB(A)}$   
 For further measurement conditions see section 3.5

a.) Operation condition:

7.200 1/min at free air flow	PWM 95 %; f: 2 kHz	PWM min.:	PWM max.:
------------------------------	--------------------	-----------	-----------

Optimal operating point	806 m3/h @ 325 Pa	
Sound power level at the optimal operating point	8,4 bel(A)	
Sound pressure level at free air flow, measured in rubber bands	75 dB(A)	

**4 Environment**

**4.1 General**

Min. permitted ambient temperature TU min.	-20 °C	
Max. permitted ambient temperature TU max.	70 °C	
Min. permitted storage temperature TL min.	-40 °C	
Max. permitted storage temperature TL max.	80 °C	

**4.2 Climatic Requirements**

Humidity requirements	humid heat, constant; according to DIN EN 60068-2-78, 14 days	
Water exposure	None	
Dust requirements	None	
Salt fog requirements	None	

Permitted application area:

The product is intended for use in sheltered rooms with controlled temperature and controlled humidity. Directly exposure to water must be avoided.

Pollution degree 1 (according DIN EN 60664-1)

There is either no pollution or it occurs only dry, non-conductive pollution. The pollution has no negative impact.

**4.3 Mechanical Requirements**

severity level	Vibration (sinusoidal)	
1 G	Vibration (sinusoidal) in use IEC 60068-2-6 Displacement / frequency range Acceleration / frequency range Sweep rate Sweep cycles	Vibration (sinusoidal) 0,075 mm / 10-58, 58-10 Hz 1 G / 58-500-58 Hz 1 Oct./min 10

Duration	2 hrs.
Axes of vibration	3

severity level	stationary use		
1	storage / transportation	Random vibration not in use IEC 60068-2-64 Frequency range / ASD  $G_{RMS}$ Axes of vibration Test duration	Random vibration 5 - 20 Hz : $1,0 \text{ m}^2 / \text{s}^3$ 20 - 500 Hz : - 3 dB / Oct 0,91 G 3 3 x 30 min
	storage / transportation	Bump not in use IEC 60068-2-29 Shock spectrum Acceleration Duration Number of bumps (+X, -X, -Y, +Y, -Z, +Z) Total bumps	Bump half sine 18 G 6 ms 100 in each direction 600
	stationary use	Random vibration in use IEC 60068-2-64 Frequency range / ASD  $G_{RMS}$ Axes of vibration Test duration	Random vibration 5 - 10 Hz : +6 dB / Oct 10 - 50 Hz : $1,0 \text{ m}^2 / \text{s}^3$ 50 - 200 Hz : - 6 dB / Oct 0,65 G 3 3 x 30 min
	stationary use	Bump in use IEC 60068-2-29 Shock spectrum Acceleration Duration Number of bumps (+X, -X, -Y, +Y, -Z, +Z) Total bumps	Bump half sine 5 G 11 ms 100 in each direction 600

severity level	Railroad application	
1 IEC 61373 Category 1 Class B	Random vibration in use IEC 60068-2-64 Frequency range / ASD  $G_{RMS}$ Axes of vibration Test duration	Random vibration 5 - 10 Hz : +6 dB / Oct 10 - 50 Hz : $1,0 \text{ m}^2 / \text{s}^3$ 50 - 200 Hz : - 6 dB / Oct 0,65 G 3 3 x 30 min
	Shock in use IEC 60068-2-27 Shock spectrum Acceleration Duration	Shock half sine 7 G 18 ms

	Number of bumps (+X, -X, -Y, +Y, -Z, +Z)	10 in each direction
	Total bumps	60

## 5 Safety

### 5.1 Electrical Safety

Dielectric strength DIN EN 60950 (VDE 0805) and DIN EN 60335 (VDE 0700) A.) Type test Measuring conditions: After 48h of storage at 95% R.H. and 25°C. No arcing or breakdown is allowed! All connections together to ground.	1000 VAC / 1 Min.	
B.) Routine test Measuring conditions: At indoor climate. No arcing or breakdown is allowed! All connections together to ground.	1000 VAC / 1 Sec.	
Isolation resistance Measuring conditions: After 48h of storage at 95% R.H. and 25°C measured with U=500 VDC for 1 min.	RI > 10 MOhm	
Clearance / creepage distance	1,0 mm / 1,2 mm	
Protection class	III	

### 5.2 Approval Tests

CE	EC Declaration of Conformity	Yes
EAC	Eurasian Conformity	Yes
UL	Underwriters Laboratories	Yes / UL507, Electric Fans
VDE	Association for Electrical, Electronic and Information Technologies	Yes / Approval acc. to EN 60950 (VDE 0805) - Information technology equipment
CSA	Canadian Standards Association	Yes / C22.2 No. 113 Fans and Ventilators
CCC	China Compulsory Certification	Not applicable

## 6 Reliability

### 6.1 General

Life expectancy L10 at TU = 40 °C	80.000 h	
Life expectancy L10 at TU max.	40.000 h	
Life expectancy L10 acc. to IPC 9591 at TU = 40 °C	135.000 h	

Copying of this document, and giving it others and the use or communication of the contents thereof, are forbidden without express authority. Offenders are liable to the payment of damages. All rights are reserved in the event of the grant of a patent or the registration of a utility model or design.

Schutzvermerk nach DIN 19105 beachten!  
Refer to protection notice DIN 19105!

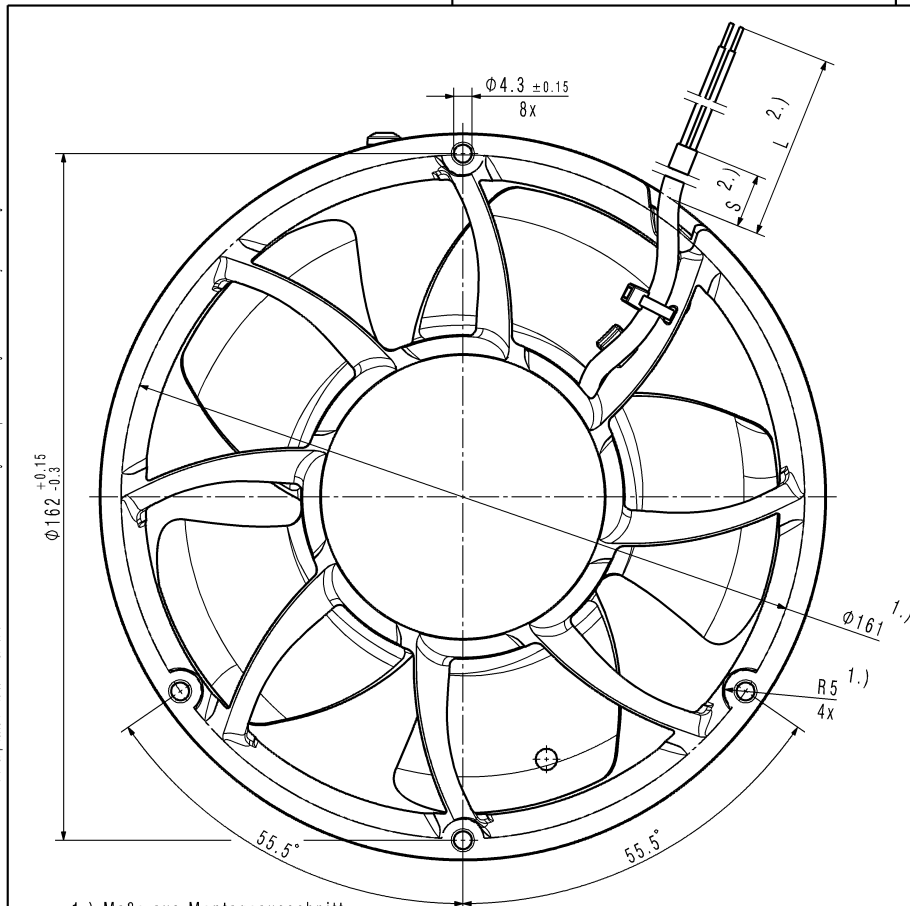

- 1.) Maße aus Montageausschnitt
- 2.) Anzahl und Länge der Litzen/Schlauch siehe Produktspezifikation
- 3.) Erdungsschraube nur wenn in der Lueftergehaeusestueckliste enthalten

- Axialspiel der Kugellager mit Feder spielfrei gelagert

- 1.) measures of mounting cut out
- 2.) length an number of wires/tube see product specification
- 3.) grounding screw only if contained in the fan housing part list

- ball bearing without clearance by a pre-load spring

SAP-Status/State	Änd.-Nr./ Change-No.	CATIA-System-Version/ CATIA-System-Version	CAD-Umgebung/ CAD-Environment	Werkstoff / Material
		9255420302 CPM000 -		
Tolerierung / Tolerances:		3D-Referenzmodell / 3D-Referenzmodell		Artikel / Title:
Allgemeintoleranzen / Gen. Tolerances:		Datum	Name	
		Bearb./ Drawn		
		Gepr./ Checked		Zugl.-Nr./ Drawing
		Freig./ Released		
<b>ebmpapst</b>				Dokumenttyp / Type of Document
ebm-papst ST.Georgen GmbH & Co KG				

## X-ON Electronics

Largest Supplier of Electrical and Electronic Components

*Click to view similar products for [DC Fans](#) category:*

*Click to view products by [ebm papst](#) manufacturer:*

Other Similar products are found below :

[614R](#) [AUB0612L](#) [AFB0948HH-S687](#) [G2E085-AA05-10](#) [4318/12T](#) [AUB0912H-F00](#) [3412N/2ME](#) [W2G110-AM39-01](#) [8412GLV](#) [8412NGL-12](#) [6448-384](#) [4114N/17-251](#) [622/2N](#) [4318/2R](#) [4412F/2D](#) [424JMU](#) [4414/2HH](#) [4112 N/12GL-175](#) [9GA0912F402](#) [9GA0812B20011](#)  
[AFB0824SHBAV1](#) [DV5214/2NP-230](#) [9GA0912H4021](#) [THC1548MGDJJ](#) [GFB1224SHG](#) [8500NU](#) [DC0401012V2B-3T0](#) [3254J/2HPU](#)  
[9A0612G402](#) [AD5012HB-C71](#) [AD5012MB-C71](#) [EF92251S3-1000U-A99](#) [PF80251B3-000U-Q99](#) [026758A](#) [3258J/2H3PU????](#) [412/2H](#) [4292](#)  
[MF60152V1-1000U-G99](#) [3610KL-04W-B50-D00](#) [EE92251B1-000U-G99](#) [8218J/2H4P](#) [4318NN](#) [4318NH3](#) [4314NL](#) [4312NM](#) [MITX-CORE-HTSNK](#) [ME45101V1-000U-A99](#) [OD1238-24HBIP55](#) [4312NHH](#) [612N/2GH](#)