

ebm-papst Mulfingen GmbH & Co. KG

Bachmühle 2 · D-74673 Mulfingen

Phone +49 7938 81-0

Fax +49 7938 81-110

info1@de.ebmpapst.com

www.ebmpapst.com

Limited partnership · Headquarters Mulfingen

Amtsgericht (court of registration) Stuttgart · HRA 590344

General partner Elektrobau Mulfingen GmbH · Headquarters Mulfingen

Amtsgericht (court of registration) Stuttgart · HRB 590142

Nominal data

Type	A2E200-AH86-75		
Motor	M2E068-BF		
Phase		1~	1~
Nominal voltage	VAC	115	115
Frequency	Hz	60	60
Method of obtaining data		fa	fa
Valid for approval/standard		CE	UL
Speed (rpm)	min ⁻¹	2700	2700
Power consumption	W	81	85
Current draw	A	0.7	0.72
Capacitor	µF	5	5
Capacitor voltage	VDB	220	220
Max. back pressure	Pa	90	90
Max. back pressure	in. wg	0.36	0.36
Min. ambient temperature	°C	-25	-25
Max. ambient temperature	°C	70	70

ml = Max. load · me = Max. efficiency · fa = Free air · cs = Customer specification · ce = Customer equipment
Subject to change



Technical description

Weight	1.3 kg
Fan size	200 mm
Rotor surface	Painted black
Blade material	Sheet steel, painted black
Number of blades	9
Airflow direction	"V"
Direction of rotation	Counterclockwise, viewed toward rotor
Degree of protection	IP44; installation- and position-dependent as per EN 60034-5
Insulation class	"B"
Moisture (F) / Environmental (H) protection class	H1
Max. permitted ambient temp. for motor (transport/storage)	+ 80 °C
Min. permitted ambient temp. for motor (transport/storage)	- 40 °C
Installation position	Shaft horizontal or rotor on top; rotor on bottom on request
Condensation drainage holes	On rotor side
Mode	S1
Motor bearing	Ball bearing
Touch current according to IEC 60990 (measuring circuit Fig. 4, TN system)	< 0.75 mA
Motor protection	Thermal overload protector (TOP) internally connected
With cable	Variable
Protection class	I (with customer connection of protective earth)
Conformity with standards	EN 60335-1; CE
Approval	CSA C22.2 No. 77; UL 1004-3

AC axial fan

sickle-shaped blades (S series)

Product drawing

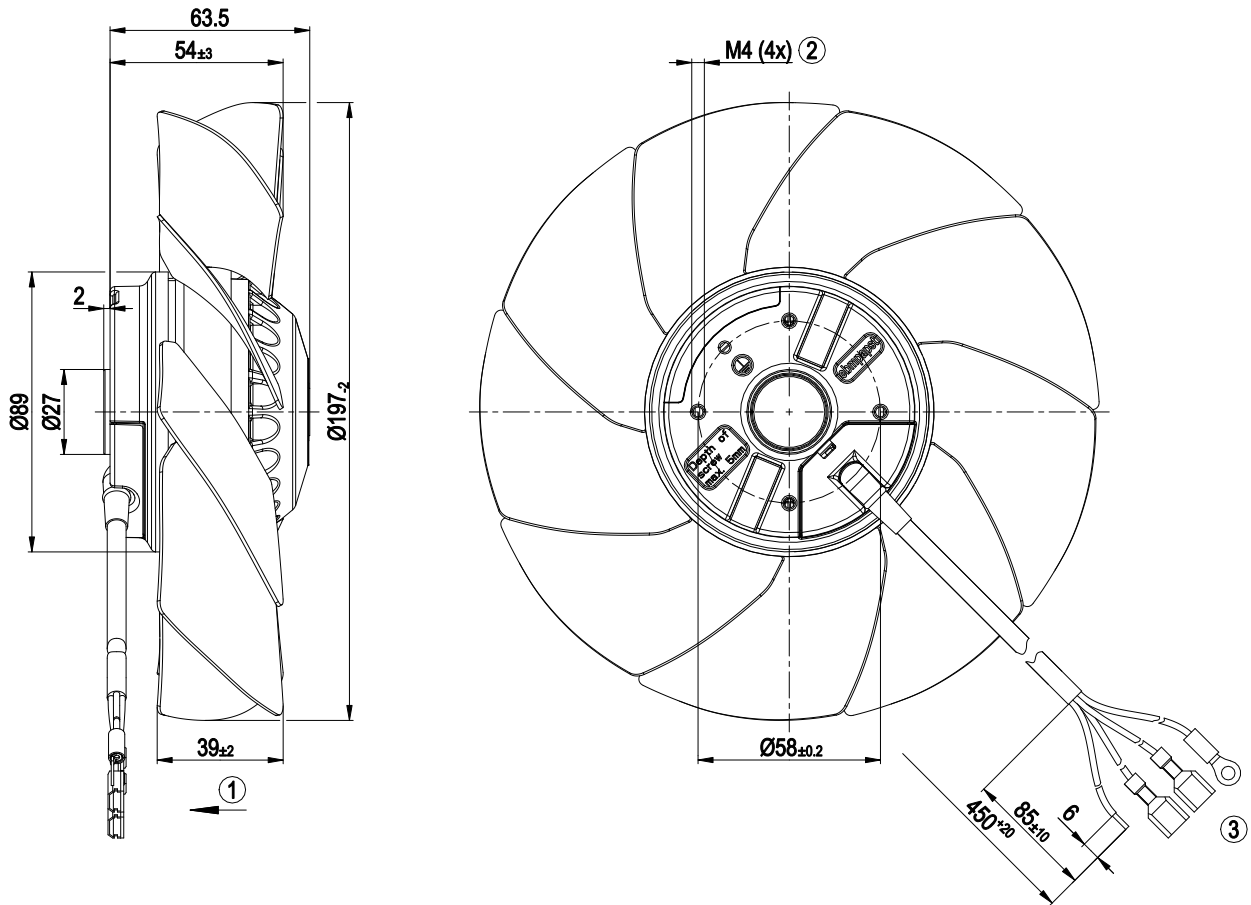

1	Airflow direction "V"
2	Max. clearance for screw 5 mm
3	Cable PFA AWG18, 1x lead tip, 2x fully insulated flat push-on receptacle, 1x insulated ring terminal

Connection diagram



U1	blue	Z	brown	U2	black
PE	green/yellow				



Curves: Air performance 60 Hz

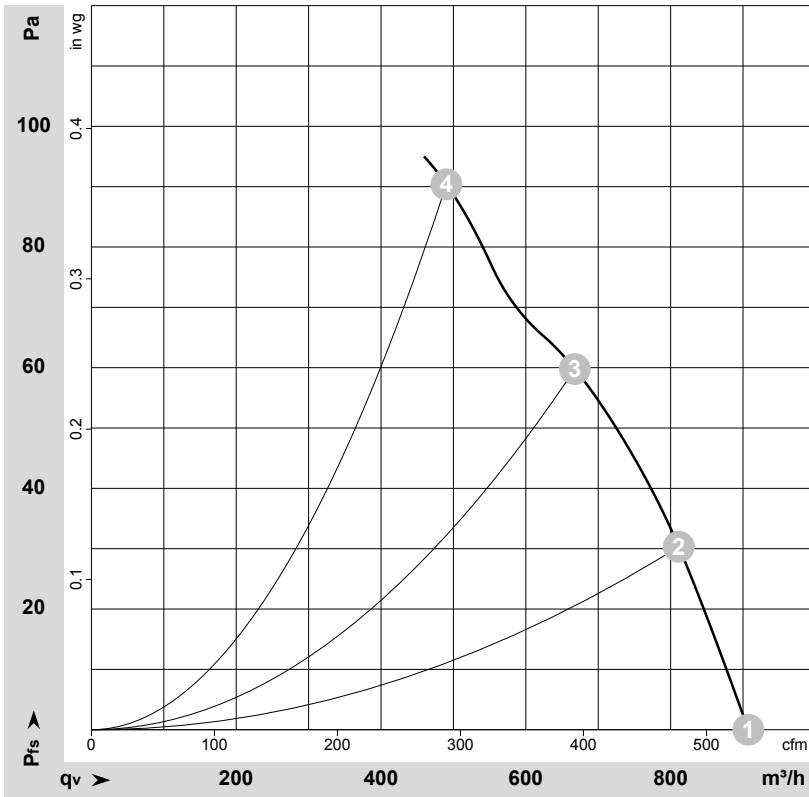

$\rho = 1.15 \text{ kg/m}^3 \pm 2 \%$

Measurement: LU-33655-1

Air performance measured according to ISO 5801 installation category A. For detailed information on the measurement setup, contact ebm-papst. Intake sound level: Sound power level according to ISO 13347 / sound pressure level measured at 1 m distance from fan axis. The values given are valid under the specified measuring conditions and may vary due to conditions of installation. For deviations from the standard configuration, the parameters have to be checked on the installed unit.

Measured values

	U	f	n	P _e	I	q _v	P _{fs}	q _v	P _{fs}
	V	Hz	min ⁻¹	W	A	m³/h	Pa	cfm	in. wg
1	115	60	2700	81	0.70	905	0	535	0.00
2	115	60	2570	85	0.74	810	30	475	0.12
3	115	60	2450	88	0.77	670	60	395	0.24
4	115	60	2370	90	0.78	490	90	290	0.36

U = Power supply · f = Frequency · n = Speed (rpm) · P_e = Power consumption · I = Current draw · q_v = Air flow · P_{fs} = Pressure increase



X-ON Electronics

Largest Supplier of Electrical and Electronic Components

Click to view similar products for [AC Fans](#) category:

Click to view products by [ebm papst](#) manufacturer:

Other Similar products are found below :

[G9225S05B2-FSR](#) [A2D200-AA04-41](#) [A2E165-AA17-01](#) [AD0912HB-A7BGL](#) [1500-FAN-01](#) [25.001.1856.0](#) [25.320.1353.1](#) [25.320.4753.1](#)
[25.320.5453.1](#) [25.330.1353.1](#) [25.330.4853.1](#) [25.330.5153.1](#) [25.330.5353.1](#) [25.340.1053.1](#) [25.350.5253.0](#) [25.600.4053.0](#) [272DL-2LP11-000](#)
[A2D210-AB10-05](#) [A2D240-AA02-02](#) [A2D250-AE22-06](#) [A2E170-AF23-01](#) [F1238S24BT-FSR](#) [23241-3](#) [25.000.1856.0](#) [25.000.2056.0](#)
[25.010.1856.0](#) [25.332.2453.1](#) [25.340.0453.1](#) [25.345.5353.0](#) [281DS-2LP11-000B](#) [281DY-1LP14-000B](#) [298DM-2LP11-000](#) [298DS-2LP11-](#)
[000A](#) [344DY-1LP11-000](#) [39.703.0253.0](#) [USTF1203224VHW](#) [3G2C7MC224](#) [W2S130-AA03-43](#) [W2S130-AA25-97](#) [8856N](#) [A4D315-AC20-](#)
[02](#) [A2E170-AF23-11](#) [W2S130-AB03-09](#) [8550A](#) [8560N](#) [8880A](#) [S4D300-AR34-17](#) [S2E250-AE31-08](#) [AD0405HB-G73\(9T\)](#) [CENT-2000-](#)
[FFTM](#)