

The HC-49UX is an "AT" cut resistance weld type Thru Hole quartz crystal.

HC-49UX QUARTZ CRYSTAL



- Cost Effective
- Excellent Aging
- "AT" Cut Crystal
- Wide Frequency Range
- PB Free/RoHS Compliant
- MSL 1

OPERATING CONDITIONS / ELECTRICAL CHARACTERISTICS

PARAMETERS	CONDITIONS	HC-49UX			UNITS
		MIN	TYP	MAX	
Frequency	Fo	1.800		100.000	MHz
Frequency Tolerance*	@ +25°C			± 30	ppm
Frequency Stability*	-10 ~ +70°C			± 50	ppm
Shunt Capacitance	Co			7	pF
Load Capacitance	Specify in P/N	10	20	Series	pF
Drive Level	DL			1.0	mW
Operating Temperature*	Topr	-10		+70	°C
Storage Temperature	Tstg	-55		+125	°C
Aging (First Year)	@ +25°C ±3°C			±5	ppm

DIMENSIONS (mm)

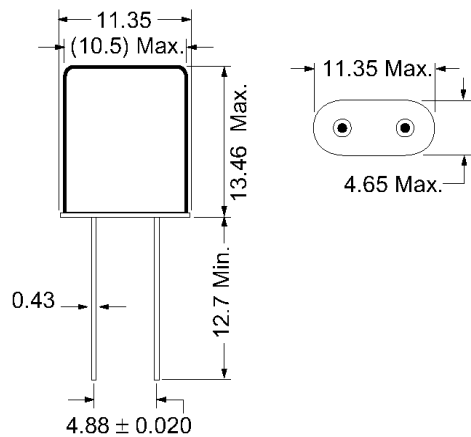

Frequency (MHz)	ESR Ω Max.	Mode of Osc.
1.800 ~ 1.999	750	Fundamental
2.000 ~ 2.399	500	Fundamental
2.400 ~ 2.999	300	Fundamental
3.000 ~ 3.199	200	Fundamental
3.200 ~ 3.699	120	Fundamental
3.700 ~ 4.199	100	Fundamental
4.200 ~ 4.899	70	Fundamental
4.900 ~ 4.999	55	Fundamental
5.000 ~ 5.999	50	Fundamental
6.000 ~ 7.999	40	Fundamental
8.000 ~ 9.999	35	Fundamental
10.000 ~ 12.499	30	Fundamental
12.500 ~ 15.999	25	Fundamental
16.000 ~ 30.000	20	Fundamental
30.000 ~ 100.000	40	3 rd Overtone

Figure 1) Side and Bottom

PART NUMBERING GUIDE: Example ECS-200-20-1X

ECS - FREQUENCY ABBREVIATION	LOAD CAPACITANCE	PACKAGE	AVAILABLE OPTIONS			PACKAGING	
			Tolerance	Stability	Temp Range		
ECS	200 = 20.000 MHz See P/N Guide	20 = 20 pF S = Series	1X = HC-49UX	Blank = Std A = ± 25 ppm J = ± 20 ppm R = ± 15 ppm C = ± 10 ppm	Blank = Std D = ± 100 ppm E = ± 50 ppm G = ± 30 ppm H = ± 25 ppm T = ± 20 ppm † W = ± 15 ppm † K = ± 10 ppm †	Blank = Std L = -10 ~ +70°C M = -20 ~ +70°C Y = -30 ~ +85°C N = -40 ~ +85°C P = -40 ~ +105°C S = -40 ~ +125°C U = -55 ~ +125°C	Bulk

* Specify available options in P/N.

† Contact ECS for availability over extended temp range.

Rev.2017

SOLDER PROFILE	
Peak solder Temp	+260°C Max 10 sec Max.
	2 Cycles Max.
	MSL 1, Lead Finish Sn/Cu Matte

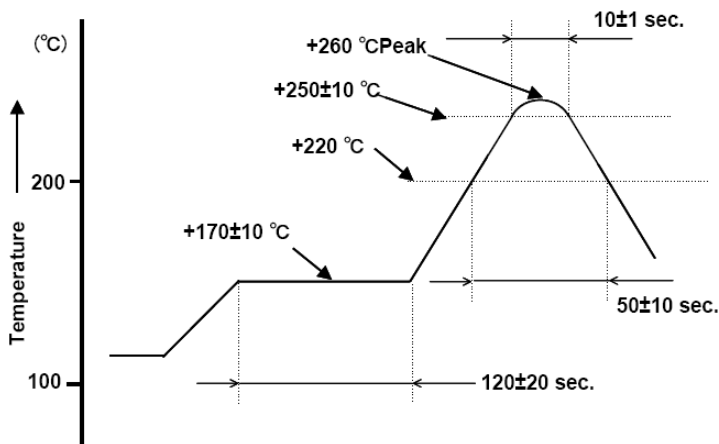

Figure 1) Suggested Solder Profile

DEVELOPED FREQUENCIES	
Abbreviation	Frequency (MHZ)
018	1.8432
020	2.000
020.48	2.048
024	2.4576
030	3.000
032	3.2768
035	3.579545
036	3.6864
039	3.93216
040	4.000
040.3	4.032
041	4.096
042	4.194304
044	4.433618
049	4.9152
050	5.000
051	5.0688
060	6.000
065	6.5536
073	7.3728
080	8.000
092.1	9.216
098.3	9.8304
100	10.000
110	11.000
110.5	11.0592
120	12.000
122.8	12.288
143	14.31818
147.4	14.7456
150	15.000
160	16.000
180	18.000
184	18.432
196.6	19.6608
200	20.000
221	22.1184
240	24.000
480	48.000

X-ON Electronics

Largest Supplier of Electrical and Electronic Components

Click to view similar products for [Crystals](#) category:

Click to view products by [ECS Inc](#) manufacturer:

Other Similar products are found below :

[CX3225GB25000M0PPSZ1](#) [718-13.2-1](#) [7A-40.000MAAE-T](#) [FL2000085](#) [99-BU](#) [9B-15.360MBBK-B](#) [9C-7.680MBBK-T](#) [H10S-12.000-18-EXT-TR](#) [ABC2-6.000MHZ-D4Z-T](#) [ABLS-20.000MHZ-D2-T](#) [ABM3B-27.000MHZ-D4Y-T](#) [ABS071-32.768KHZ-6-T](#) [R38-32.768-12.5-5PPM-NPB](#) [BTD1062E05A-513](#) [C711980XFAS30XX](#) [21U15A-21.4MHZ](#) [RTX-781DF1-S-20.950](#) [LFXTAL066198Cutt](#) [9C-14.31818MBBK-T](#) [A-11.000MHZ-27](#) [ABL-27.000MHZ-B4Y-T](#) [ABM11-132-24.000MHZ-T3](#) [ABM3B1-25.000MHZ-D2Y-T](#) [SPT2A-.032768B](#) [SPT2A.032768G](#) [SSPT7F-9PF20-R](#) [LFXTAL065253Cutt](#) [LFXTAL066431Cutt](#) [XT9S20ANA14M7456](#) [XT9SNLANA16M](#) [7A-24.576MBBK-T](#) [7B-30.000MBBK-T](#) [CX2520DB16000H0HPQCC](#) [MMCC2R32.7680KHZ](#) [7A-14.31818MBBK-T](#) [6504-202-1501](#) [6526-202-1501](#) [ABLS-12.000MHZ-B2Y-T](#) [7A-10.000MBBK-T](#) [SG636PCE-20.000MC](#) [3404](#) [CM315D32768EZFT](#) [C1E-24.000-7-2020-R](#) [C1E-19.200-12-1530-X-R](#) [C1E-16.000-12-1530-X-R](#) [ABM11-16.000MHZ-9-B1U-T](#) [FL5000014](#) [EUCA18-3.1872M](#) [FX0800015](#)
[425F35E027M0000](#)