

THIS IS A C.A.D. GENERATED DRAWING
DO NOT MAKE MANUAL REVISIONS TO MASTER.

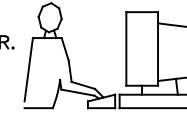

ISSUE NUMBER

ORIGINAL

①

TO OPEN PARTIALLY CLOSED TOOL
PUSH THIS LATCH IN THE DIRECTION
OF THE ARROW.

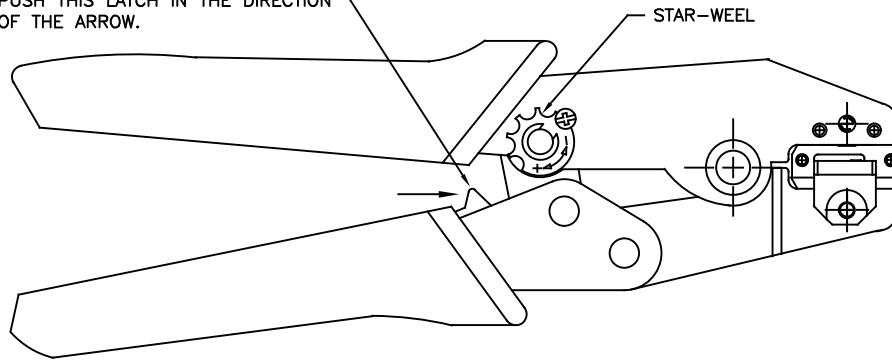

STAR-WHEEL

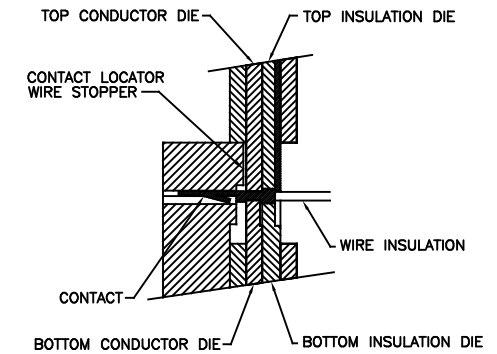

SECTION THROUGH DIE NEST
WITH CONTACT IN POSITION

NOTES:

| WIRE AWG | CRIMP STRENGTH |
|----------|----------------|
| 20 AWG | 15.4 LBS |
| 22 AWG | 11.0 LBS |
| 24 AWG | 6.6 LBS |
| 26 AWG | 4.4 LBS |
| 28 AWG | 2.2 LBS |

- 1- THIS HAND TOOL IS DESIGNED FOR CRIMPING 20 TO 28 AWG WIRES TO EDAC CONTACT P/N 565-290-711/721/731/741.
- 2- RISK OF ELECTRIC SHOCK- DO NOT USE THIS ON LIVE WIRE.
- 3- CRIMPING INSTRUCTIONS:
 - OPEN THE TOOL, PLACE THE CONTACT INTO THE CORRECT DIE NEST.
 - PARTIALLY CLOSE THE TOOL UNTIL THE CONTACT IS HELD IN PLACE. INSERT THE WIRE INTO THE CONTACT.
 - CLOSE THE TOOL UNTIL THE RATCHET RELEASES. REMOVE THE CRIMPED CONTACT.
- 4- ADJUSTMENT OF CRIMP FORCE (WHEN NECESSARY):
 - LOOSEN THE SCREW
 - ADJUST THE STAR-WHEEL BY TURNING FROM (-) TO(+).
 - CHECK THE PRELOAD AND THE CRIMP FORCE.

TOOL PART NUMBER: 565-280-201

| | | | |
|---|--|--------------------------------|------------------|
| 565 SERIES HAND CRIMP TOOL INSTRUCTIONS | | ACAD REFERENCE NO. 565-280-201 | |
| | | DRAWN: K.L. | DATE: AUG.6/2020 |
| EDAC INC TORONTO, ONTARIO CANADA YOUR CONNECTION TO QUALITY & SERVICE | | CHECKED: R.S.M. | DATE: AUG.6/2020 |
| | | SCALE: N.T.S. | SHEET 1 OF 2 |
| THESE DRAWINGS AND SPECIFICATIONS ARE THE PROPERTY OF EDAC INC., AND SHALL NOT BE REPRODUCED, OR COPIED OR USED AS THE BASIS FOR THE MANUFACTURE OR SALE OF APPARATUS WITHOUT WRITTEN PERMISSION. | | DRAWING NUMBER | |
| | | 565-280-201 | |
| | | ISSUE 1 | |

THIS IS A C.A.D. GENERATED DRAWING
DO NOT MAKE MANUAL REVISIONS TO MASTER.



ISSUE NUMBER

ORIGINAL

①

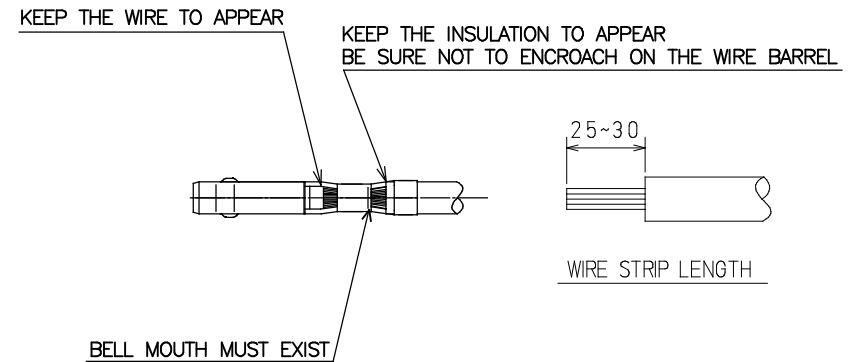
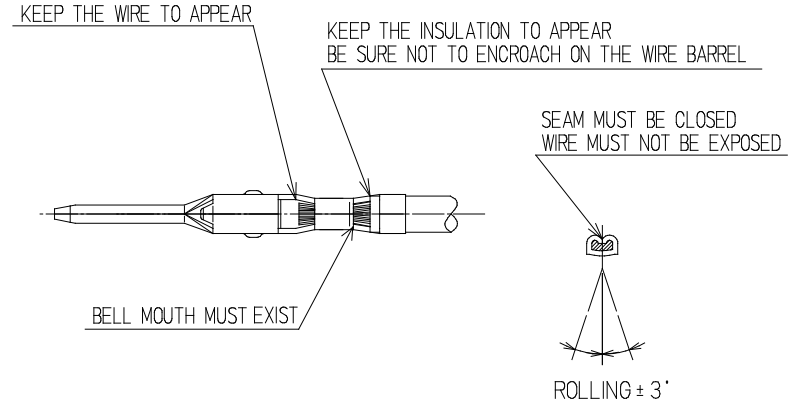
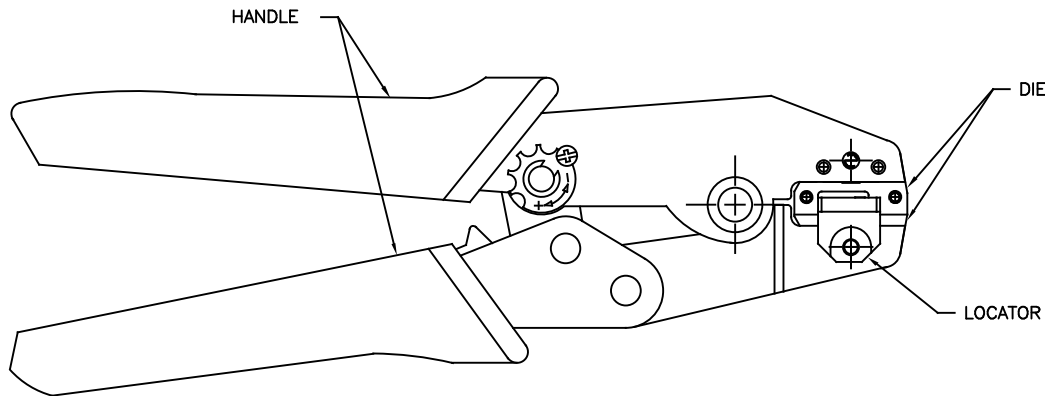

| CRIMP ASM* | HANDLE | DIES | LOCATOR |
|-------------|-------------|-------------|-------------|
| 565-280-201 | 565-281-001 | 565-281-002 | 565-281-003 |

* Assembly includes: Handle, Die and Locator. Parts are available for purchase separately.

565 SERIES HAND CRIMP TOOL INSTRUCTIONS

EDAC
EDAC INC
TORONTO, ONTARIO
CANADA
YOUR CONNECTION TO QUALITY & SERVICE

THESE DRAWINGS AND SPECIFICATIONS
ARE THE PROPERTY OF EDAC INC., AND
SHALL NOT BE REPRODUCED, OR COPIED
OR USED AS THE BASIS FOR THE
MANUFACTURE OR SALE OF APPARATUS
WITHOUT WRITTEN PERMISSION.

ACAD REFERENCE NO. 565-280-201

DRAWN: K.L.

DATE: AUG.6/2020

CHECKED: R.S.M.

DATE: AUG.6/2020

SCALE: N.T.S.

SHEET 2 OF 2

DRAWING NUMBER

565-280-201

ISSUE

1

X-ON Electronics

Largest Supplier of Electrical and Electronic Components

Click to view similar products for [Crimpers / Crimping Tools](#) category:

Click to view products by [EDAC](#) manufacturer:

Other Similar products are found below :

[010-0096](#) [CT150-2-D02](#) [CT150-6-RH07](#) [622-6441LF](#) [63484-3701](#) [63800-8355](#) [63819-1875](#) [63819-2875](#) [63819-4475](#) [63827-5375](#) [64005-0175](#) [662903-2](#) [690602-6](#) [7-23471-1](#) [734611-1](#) [762637-1](#) [811242-5](#) [91362-1](#) [1-21002-3](#) [1-21002-7](#) [12118040](#) [12085270](#) [12387119-6](#) [1-22548-4](#) [125442-1](#) [DCE.91.073.BVC](#) [DCE.91.090.3MVM](#) [DCE.91.162.BVCM](#) [DCE.91.202.BVCM](#) [1310G2](#) [1333249-1](#) [1-354003-0](#) [1338301-1](#) [DF62/RE-MD](#) [142321](#) [AP105-DF11-2428S\(64\)](#) [1456088-1](#) [1-45804-6](#) [15397700](#) [AX100749](#) [1-59619-7](#) [1596970-1](#) [1-59619-8](#) [1901238-2](#) [2119581-1](#) [K761](#) [KTH-1079](#) [KTH-2022](#) [KTH-2260](#) [904139-1](#)