

THIS IS A C.A.D. GENERATED DRAWING
DO NOT MAKE MANUAL REVISIONS TO MASTER.

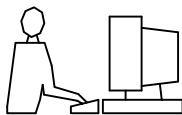

* UNLESS OTHERWISE SPECIFIED TOLERANCES
ON DECIMAL IS:

X.X
X.XX
X.XXX

ISSUE NUMBER

ORIGINAL ①

DIM 1.6 WAS 1.3 ②
R.STA.MONICA SEPT.24/2012

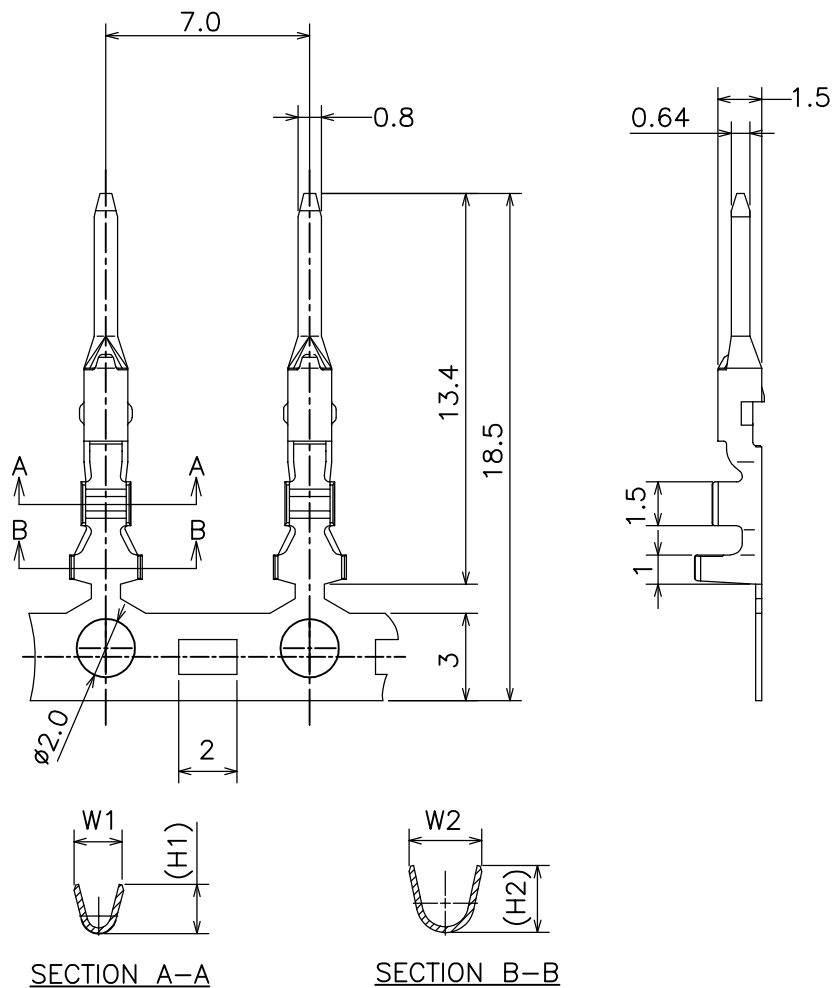

NOTES

MATERIAL: PHOSPHOR BRONZE
0.2mm THICK
TIN PLATED ALL OVER

PART NO	W1	H1	W2	H2	WIRE RANGE	INSULATION DIA
565-290-711	1.7	1.7	2.6	2.4	AWG # 22~28	MAXIMUM ϕ 1.6
565-290-731	1.9	1.9	3.0	2.7	AWG # 20~22	MAXIMUM ϕ 1.7

②

PIN CONTACT

ACAD REFERENCE NO. 565-290-711 & 731

DRAWN: N.SONDH

DATE: SEP 10/12

CHECKED:

DATE:

SCALE: (IN C.A.D.1:1)

SHEET 1 OF 3

DRAWING NUMBER

ISSUE

565-290-711 & 731

2



EDAC INC
TORONTO, ONTARIO
CANADA

YOUR CONNECTION TO QUALITY & SERVICE

THESE DRAWINGS AND SPECIFICATIONS
ARE THE PROPERTY OF EDAC INC., AND
SHALL NOT BE REPRODUCED, OR COPIED
OR USED AS THE BASIS FOR THE
MANUFACTURE OR SALE OF APPARATUS
WITHOUT WRITTEN PERMISSION.

THIS IS A C.A.D. GENERATED DRAWING
DO NOT MAKE MANUAL REVISIONS TO MASTER.

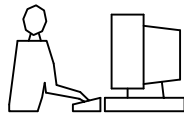

* UNLESS OTHERWISE SPECIFIED TOLERANCES
ON DECIMAL IS:

X.X
X.XX
X.XXX

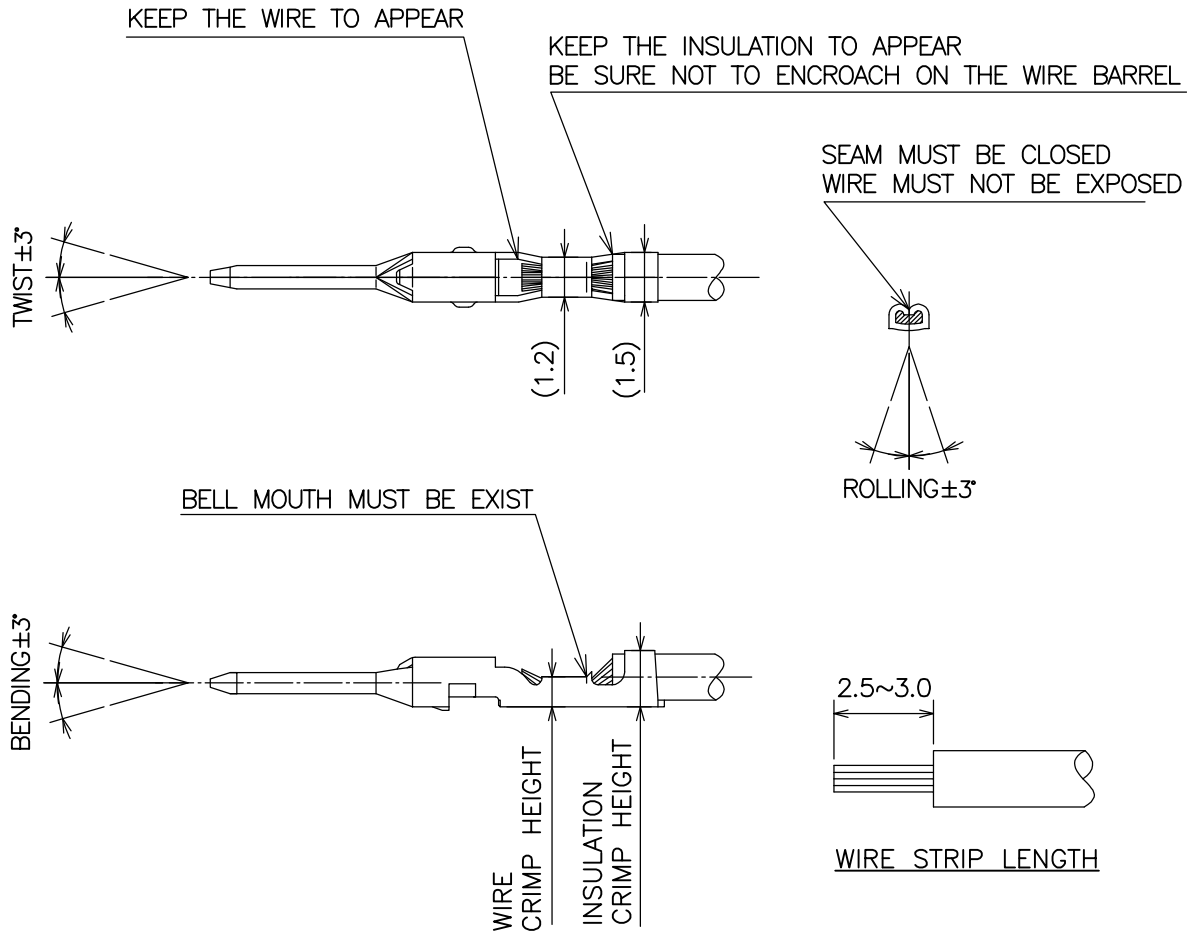

WIRE CRIMP INFORMATION FOR 565-290-711 CONTACT
WITH INSULATION DIA 1.0mm TO 1.3mm
(565-290-711 CONTACT TO BE CRIMPED WITH TOOL# 565-280-210)

WIRE SIZE	INSULATION DIA	WIRE CRIMP HEIGHT	INSULATION CRIMP HEIGHT	CRIMP STRENGTH
AWG # 22	-----	0.80±0.03	1.7 MAX	49.0 N(5.0Kgf)MIN
AWG # 24	-----	0.75±0.03	1.7 MAX	29.4 N(3.0Kgf)MIN
AWG # 26	-----	0.67±0.03	1.7 MAX	19.6 N(2.0Kgf)MIN
AWG # 28	-----	0.63±0.03	1.7 MAX	9.8 N(1.0Kgf)MIN

PIN CONTACT
WIRE CRIMP INFORMATION

ACAD REFERENCE NO. 565-290-711 & 731

DRAWN: N.SONDH

DATE: SEP 10/12

CHECKED:

DATE:

SCALE: (IN C.A.D.1:1)

SHEET 2 OF 3

DRAWING NUMBER

565-290-711 & 731

ISSUE

2



EDAC INC
TORONTO, ONTARIO
CANADA

YOUR CONNECTION TO QUALITY & SERVICE

THESE DRAWINGS AND SPECIFICATIONS
ARE THE PROPERTY OF EDAC INC., AND
SHALL NOT BE REPRODUCED, OR COPIED
OR USED AS THE BASIS FOR THE
MANUFACTURE OR SALE OF APPARATUS
WITHOUT WRITTEN PERMISSION.

THIS IS A C.A.D. GENERATED DRAWING
DO NOT MAKE MANUAL REVISIONS TO MASTER.

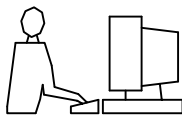

* UNLESS OTHERWISE SPECIFIED TOLERANCES
ON DECIMAL IS:

X.X
X.XX
X.XXX

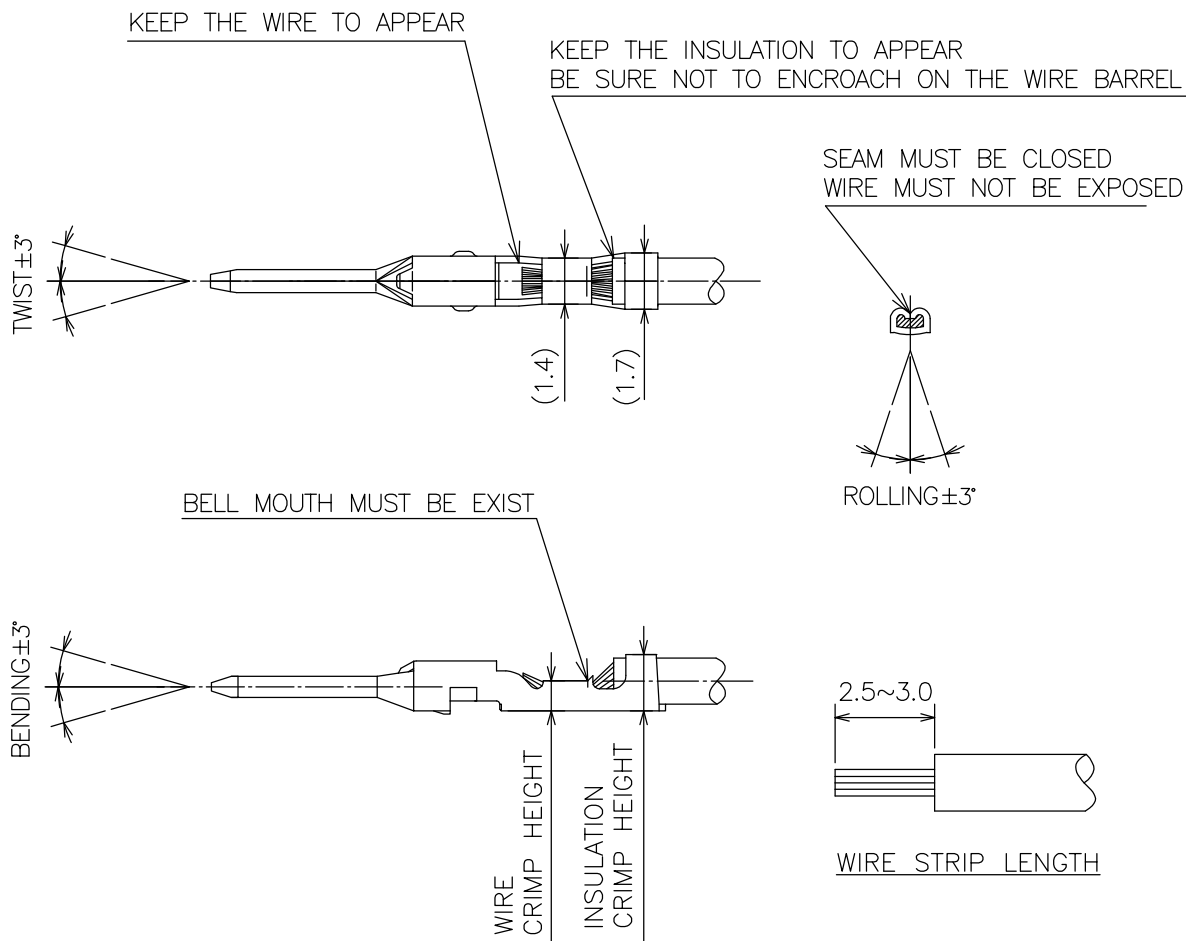

WIRE CRIMP INFORMATION FOR 565-290-731 CONTACT
WITH INSULATION DIA 1.3mm TO 1.7mm
(565-290-731 CONTACT TO BE CRIMPED WITH TOOL# 565-280-211)

WIRE SIZE	INSULATION DIA	WIRE CRIMP HEIGHT	INSULATION CRIMP HEIGHT	CRIMP STRENGTH
AWG # 20	-----	0.87 \pm 0.03	1.8 MAX	68.6 N(7.0Kgf)MIN
AWG # 22	-----	0.81 \pm 0.03	1.8 MAX	49.0 N(5.0Kgf)MIN

PIN CONTACT
WIRE CRIMP INFORMATION

ACAD REFERENCE NO. 565-290-711 & 731

DRAWN: N.SONDH

DATE: SEP 10/12

CHECKED:

DATE:

SCALE: (IN C.A.D.1:1)

SHEET 3 OF 3

DRAWING NUMBER

ISSUE

565-290-711 & 731

2



EDAC INC
TORONTO, ONTARIO
CANADA

YOUR CONNECTION TO QUALITY & SERVICE

THESE DRAWINGS AND SPECIFICATIONS
ARE THE PROPERTY OF EDAC INC., AND
SHALL NOT BE REPRODUCED, OR COPIED
OR USED AS THE BASIS FOR THE
MANUFACTURE OR SALE OF APPARATUS
WITHOUT WRITTEN PERMISSION.

X-ON Electronics

Largest Supplier of Electrical and Electronic Components

Click to view similar products for [Pin & Socket Connectors](#) category:

Click to view products by [EDAC](#) manufacturer:

Other Similar products are found below :

[6450822-1](#) [770392-1](#) [794042-1](#) [796885-1](#) [8-794535-1](#) [PLR3455ACS-222](#) [R929991004](#) [R929993003](#) [1403611-1](#) [1-480349-5](#) [152302-5](#)
[153211-2](#) [1586092-1](#) [1586129-1](#) [1586681-4](#) [1586700-1](#) [1586368-1](#) [1586380-1](#) [1586616-1](#) [1586680-5](#) [16-06-0038](#) [164164-5](#) [1-6609930-1](#)
[172296-1](#) [19-09-2035](#) [200503-1](#) [200788-2](#) [2029090-4](#) [2029095-4](#) [925061-7](#) [293734-4](#) [293737-2](#) [1-765362-4](#) [1871534-1](#) [200833-4](#)
[2008625-2](#) [2029027-2](#) [2029096-4](#) [R929991000](#) [R929991002](#) [R929993000](#) [319-10-101-00-005000](#) [319-10-102-00-001000](#) [319-10-104-00-001000](#) [319-10-105-00-001000](#) [319-10-108-00-001000](#) [319-10-112-00-006000](#) [39-01-8019](#) [319-10-101-00-001000](#) [319-10-102-00-005000](#)