

Full color IPS Display with 24 Bit RGB interface

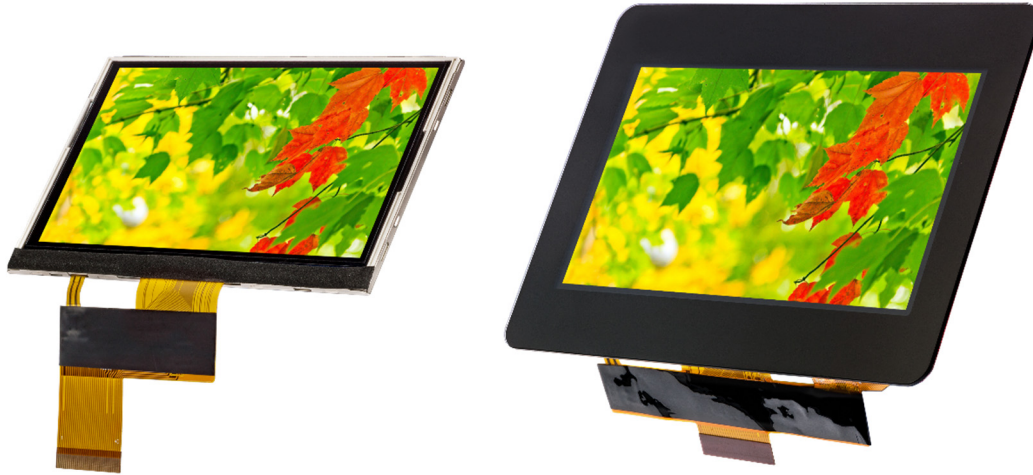

Left: 105.4x67.1x2.65mm

Right: 114.0x84.0x4.8mm (incl. PCAP)

FEATURES

- 4.3" TFT FULL COLOR
- AACS TECHNOLOGY WITH IPS FOR UNLIMITED VIEWING ANGLE
- 480x272x3 DOTS
- 1000/800cd/m² WITHOUT/WITH TOUCHPANEL
- 24-BIT RGB INTERFACE
- INTEGRATED CONTROLLER SC7283
- SINGLE SUPPLY 3.3V
- WIDE TEMPERATURE RANGE (T_{OP} -20°C - +70°C)
- OPTIONALLY WITH PCAP AND TOUCH CONTROLLER GT911

ORDERING CODES

- 4.3" TFT, 480x272 IPS, 1000cd/m²
- AS ABOVE BUT WITH OPTICALLY BONDED PCAP

**EA R480X-43ALW
EA TFT043-42BITC**

ACCESSORY

- ZIF CONNECTOR 0.5mm, BOTTOM CONTACT
- ZIF CONNECTOR 0.5mm, TOP CONTACT

**EA WF050-40S
EA WF050-40ST**

CONTENTS

- GENERAL FEATURES
- ABSOLUTE MAXIMUM RATINGS
- ELECTRICAL SPECIFICATIONS
- OPTICAL SPECIFICATIONS
- BLOCK DIAGRAM
- PIN DESCRIPTION
- TIMING CHARACTERISTICS
- PCAP TOUCHPANEL GT911
- OUTLINE DIMENSION
- RELIABILITY AND INSPECTION STANDARD
- PRECAUTIONS

1. General Features

Item	Spec	Remark
Display Mode	Normally Black Transmissive	
Viewing Direction	FREE	
Input Signals	RGB 24 bit	
Outside Dimensions	105.4(W) x67.1(H) x2.65(D)	
	114.0(W) x84.0(H) x4.77(D)	With CTP
Active Area	95.04mm(W) × 53.86mm(H)	
Number of Pixels	480(RGB) × 272	
Dot Pitch	0.198mm(H) × 0.198mm(W)	
Pixel Arrangement	RGB Vertical stripes	
Drive IC	SC7283	
CTP IC	GT911	With CTP

2. Absolute Maximum Ratings

The following are maximum values which, if exceeded may cause operation or damage to the unit.

ITEM	Sym.	Min.	Typ.	Max.	Unit	Remark
Power for Circuit Driving	Vdd	-0.3	-	4.6	V	
Power for Circuit Logic	Vt	-0.3	-	Vdd+0.3	V	
Storage Humidity	H _{ST}	10	-		%RH	At 25±5°C
Storage Temperature	T _{ST}	-30	-	80	°C	
Operating Ambient Humidity	H _{OP}	10	-		%RH	
Operating Ambient temperature	T _{OP}	-20	-	70	°C	

3. Electrical Specification

3.1 Driving TFT LCD Panel

Item	Sym.	Min	Typ.	Max	Unit	Note	
Power for Circuit Driving	VDD	3.0	3.3	3.6	V		
Logic Input Voltage	Low Voltage	V _{IL}	0	-	0.3V _{dd}	V	
	High Voltage	V _{IH}	0.7V _{dd}	-	V _{dd}	V	
Logic Output Voltage	Low Voltage	V _{OL}	0	-	0.2V _{dd}	V	
	High Voltage	V _{OH}	0.8V _{dd}	-	-	V	
Power Consumption	Black Mode	P _b	T.B.D	T.B.D	T.B.D	mW	
	Standby Mode	P _w	T.B.D	T.B.D	T.B.D	mW	

3.2 Driving Backlight

Item	Sym.	Min	Typ.	Max	Unit	Note
Backlight driving voltage	V _F	24.4	25.6	27.2	V	
Backlight driving current	I _F	-	40	-	mA	
Backlight Power Consumption	W _{BL}	-	1024	-	mW	
Life Time	-	-	30,000	-		Note 3

Note 1: (Unless specified, the ambient temperature Ta=25°C)

Note 2: The recommended operating conditions refer to a range in which operation of this product is guaranteed. Should this range is exceeded, the operation cannot be guaranteed even if the values may be without the absolute maximum ratings.

Note 3: If LED is driven by high current, high ambient temperature & humidity condition. The life time of LED will be reduced. Operating life means brightness goes down to 50% initial brightness. Typical operating life time is estimated data.

4.Optical Specifications

Optical characteristics are determined after the unit has been 'ON' and stable for approximately 30 minutes in a dark environment at 25 °C. The values specified are at an approximate distance 500mm from the LCD surface at a viewing angle of Φ and θ equal to 0°.

Item	Sym.	Values			Unit	Note
		Min.	Typ.	Max.		
Contrast Ratio	C/R	640	800	-		FIG.1
Module Luminance		900	1000		cd/m ²	EA R480X-43ALW
	L	700	800	-		EA TFT043-42BITC
Response time	Tr+Tf	-	30	40	ms	FIG.2
Viewing Angle	θ_T	70	80	-	Degree	FIG.3
	θ_B	70	80	-		
	θ_L	70	80	-		
	θ_R	70	80	-		
)Chromaticity	Wx	0.280	0.320	0.360		
	Wy	0.305	0.345	0.384		
	Rx	-	-	-		
	Ry	-	-	-		
	Gx	-	-	-		
	Gy	-	-	-		
	Bx	-	-	-		
	By	-	-	-		



◆ **Measurement System**

Notes:

1. Contrast Ratio(CR) is defined mathematically as :

$$\text{Contrast Ratio} = \frac{\text{Surface Luminance with all white pixels}}{\text{Surface Luminance with all black pixels}}$$

2. Surface luminance is the center point across the LCD surface 500mm from the surface with all pixels displaying white. For more information see FIG 1.

3. Response time is the time required for the display to transition from white to black (Rising Time, Tr) and from black to white (Falling Time, Tf). For additional information see FIG 2.

4. Viewing angle is the angle at which the contrast ratio is greater than 10. The angles are determined for the horizontal or x axis and the vertical or y axis with respect to the z axis which is normal to the LCD surface. For more information see FIG 3.

FIG. 1 Optical Characteristic Measurement Equipment and Method

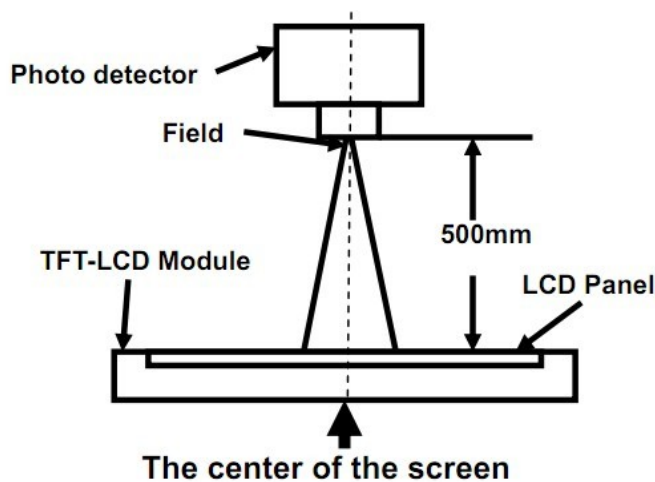

Item	Photo detector	Field
Contrast Ratio	SR-3A	1°
Luminance		
Chromaticity		
Lum Uniformity	BM-7A	2°
Response Time		

FIG. 2 The definition of Response Time

The response time is defined as the following figure and shall be measured by switching the input signal for “black” and “white”.

Response Time = Rising Time(T_r) + Falling Time(T_f)

- Rising Time(T_r) : Full White 90% → Full White 10% Transmittance.
- Falling Time(T_f) : Full White 10% → Full White 90% Transmittance.

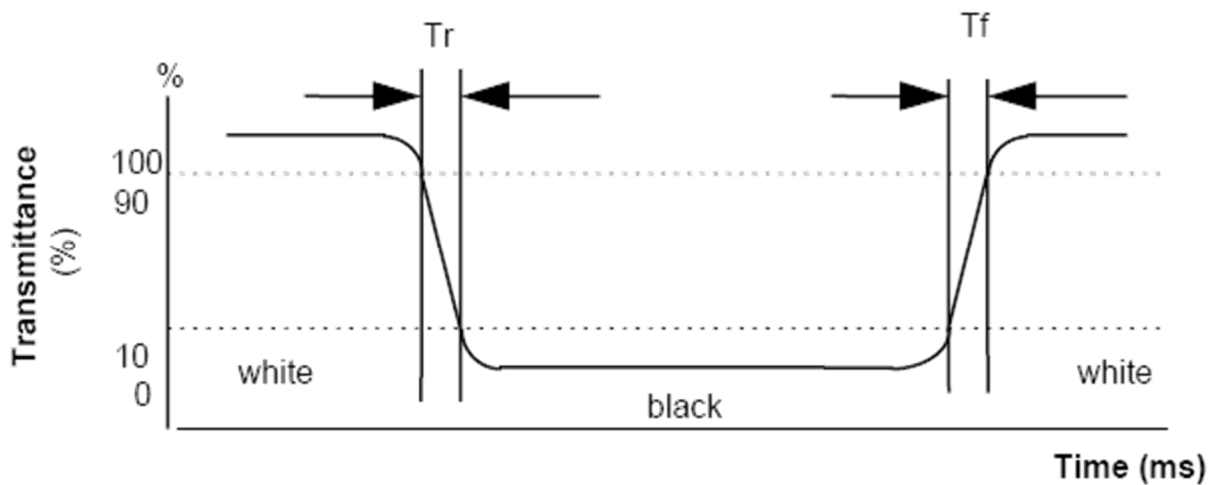
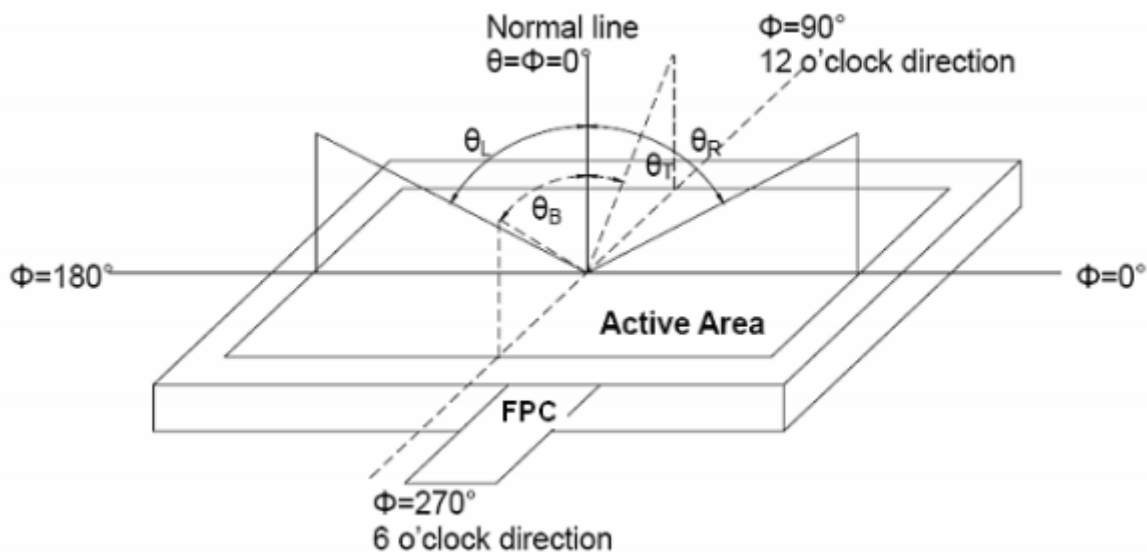
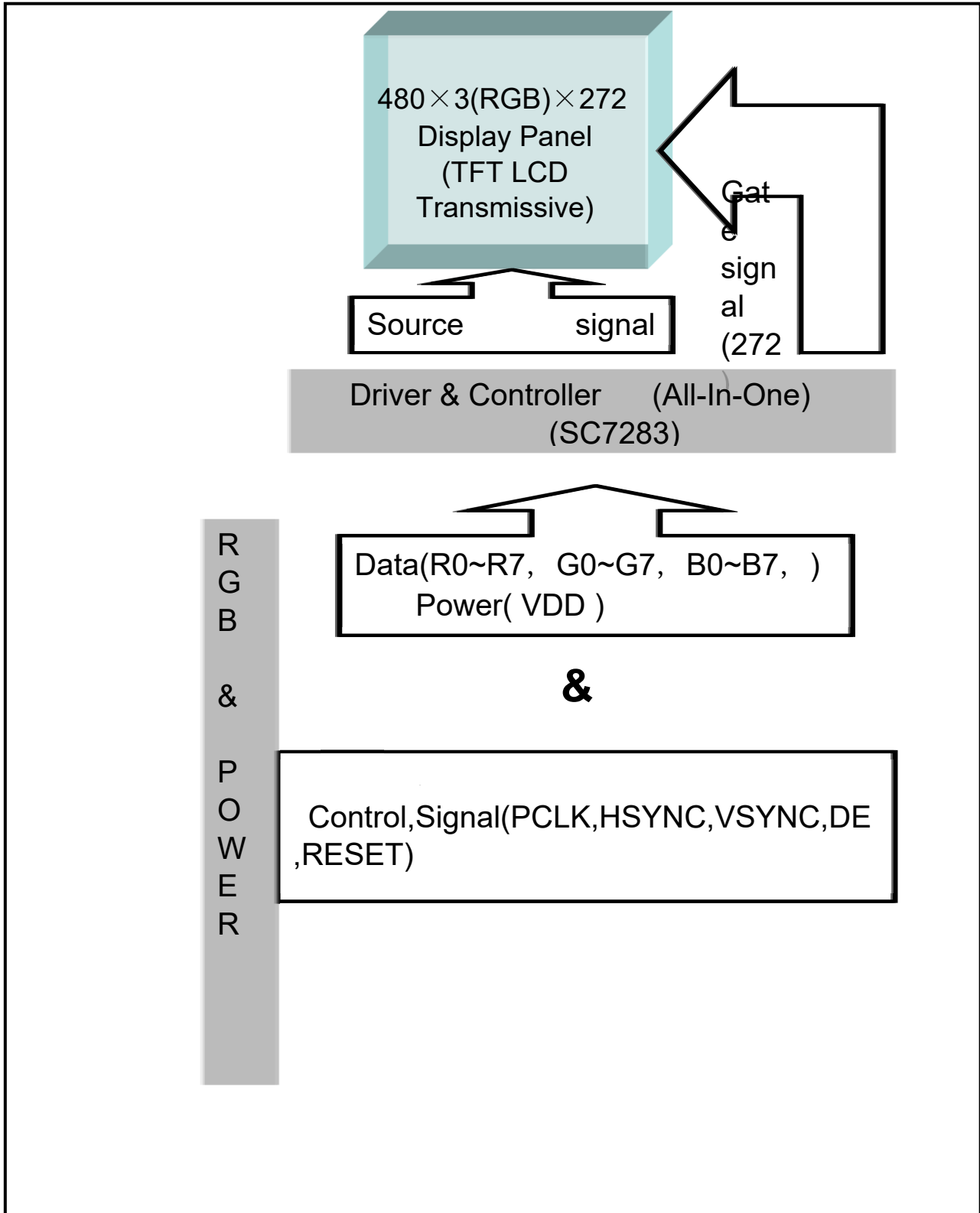

FIG. 3 The definition of Viewing Angle

Use Fig. 1(Test Procedure) under Measurement System to measure the contrast from the measuring direction specified by the conditions as the following figure.



5. Block Diagram



6.Pin Description

6.1 EA R480X-43ALW

Item	Symbol	Description
1	VLED-	B/L Power input PIN Cathode
2	VLED+	B/L Power input PIN anode
3	NC	
4	VDD	Power supply
5--12	R0--R7	Red Data
13--20	G0--G7	Green Data
21--28	B0--B7	Blue Data
29	GND	Ground
30	DCLK	Data clock signal
31	NC	
32	HSYNC	Horizontal synchronizing signal
33	VSYNC	Vertical synchronizing signal
34	DE	Data ENABLE signal
35	NC	NC
36	GND	Ground
37	NC	
38	NC	
39	NC	
40	NC	

Note: FPC 40 pins, 0.5mm pitch

6.2 EA TFT043-42BITC with Touchpanel

Item	Symbol	Description
1	VLED-	B/L Power input PIN Cathode
2	VLED+	B/L Power input PIN anode
3	TFT/CTP GND	TFT/CTP Ground
4	TFT/CTP VDD	TFT/CTP Power input
5--12	R0--R7	Red Data
13--20	G0--G7	Green Data
21--28	B0--B7	Blue Data
29	TFT/CTP GND	TFT/CTP Ground
30	DCLK	Data clock signal
31	DISP	Standby Mode DISP="1", Normal operation DISP="0", Standby mode.
32	HSYNC	Horizontal synchronizing signal
33	VSYNC	Vertical synchronizing signal
34	DE	Data ENABLE signal
35	NC	NC
36	TFT RST	TFT reset pin
37	CTP RST	CTP reset pin
38	CTP SCL	CTP I2C clock
39	CTP SDA	CTP I2C data
40	CTP INT	CTP interrupt

Note: FPC 40 pins, 0.5mm pitch

7. Timing Characteristics

7.1 Timing Diagram and Input Setup Timing setting

7.1.1 SYNC Mode Timing Diagram

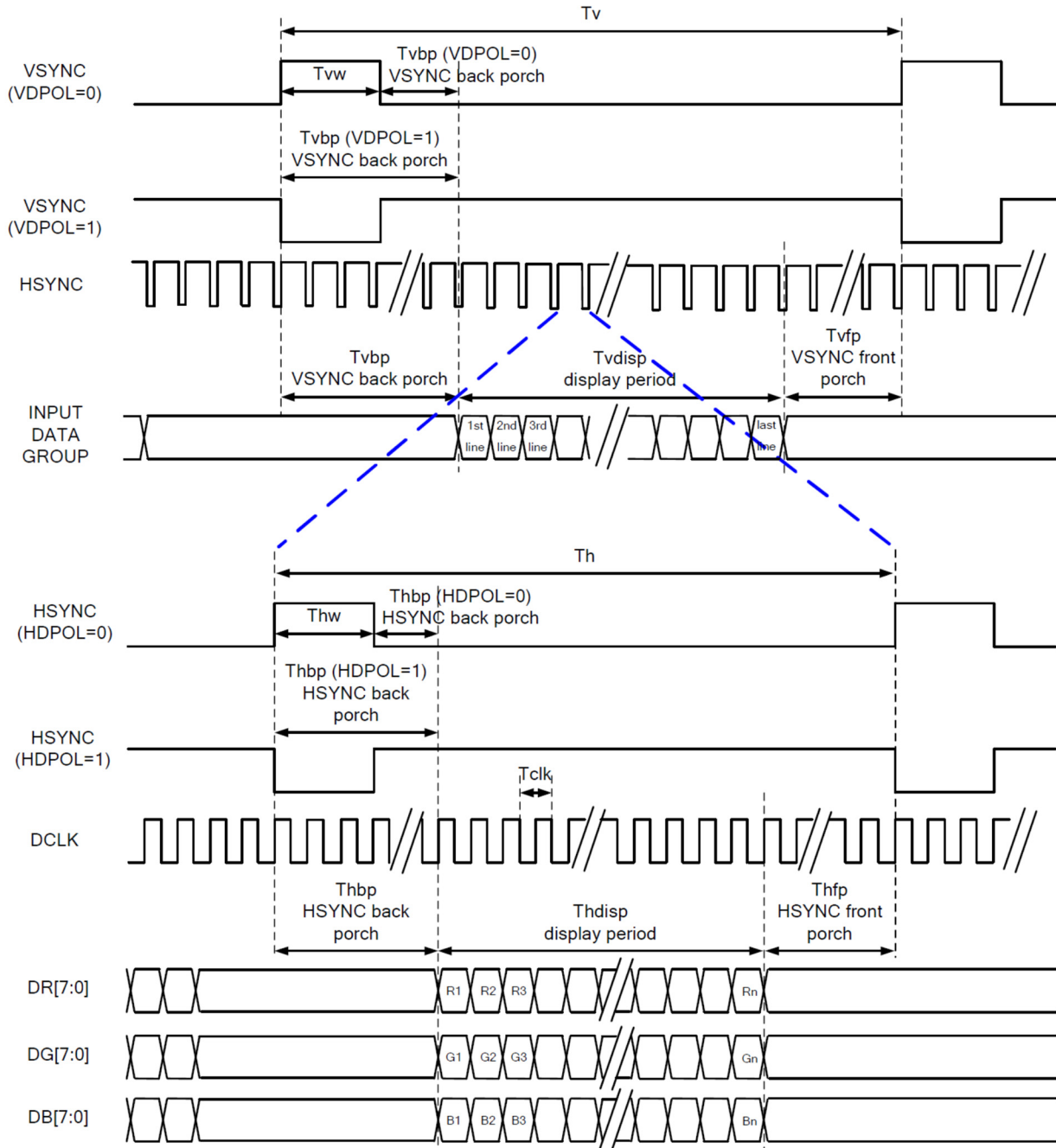

7.1.2 SYN-DE Mode Timing Diagram

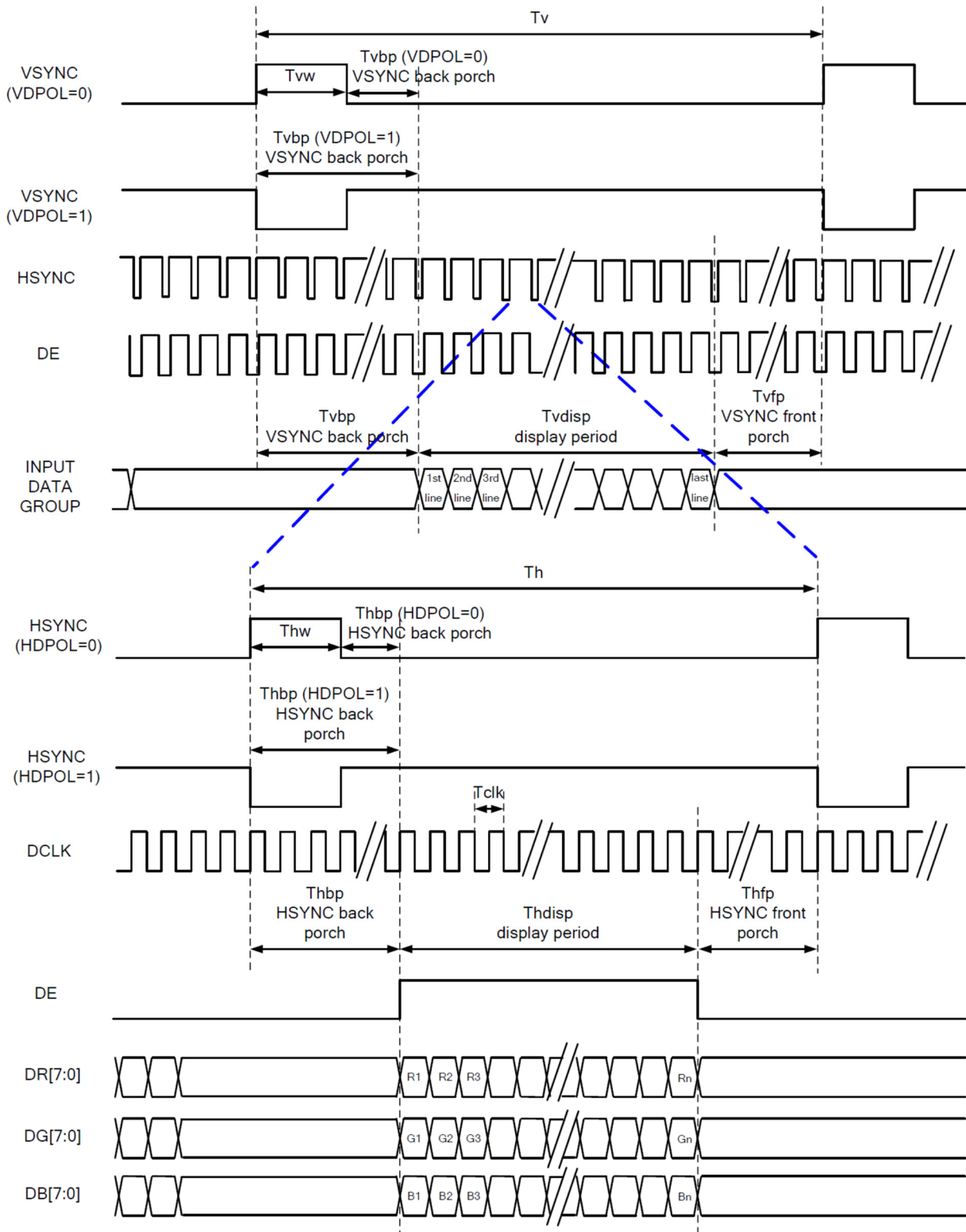

7.1.3 DE Mode Timing Diagram

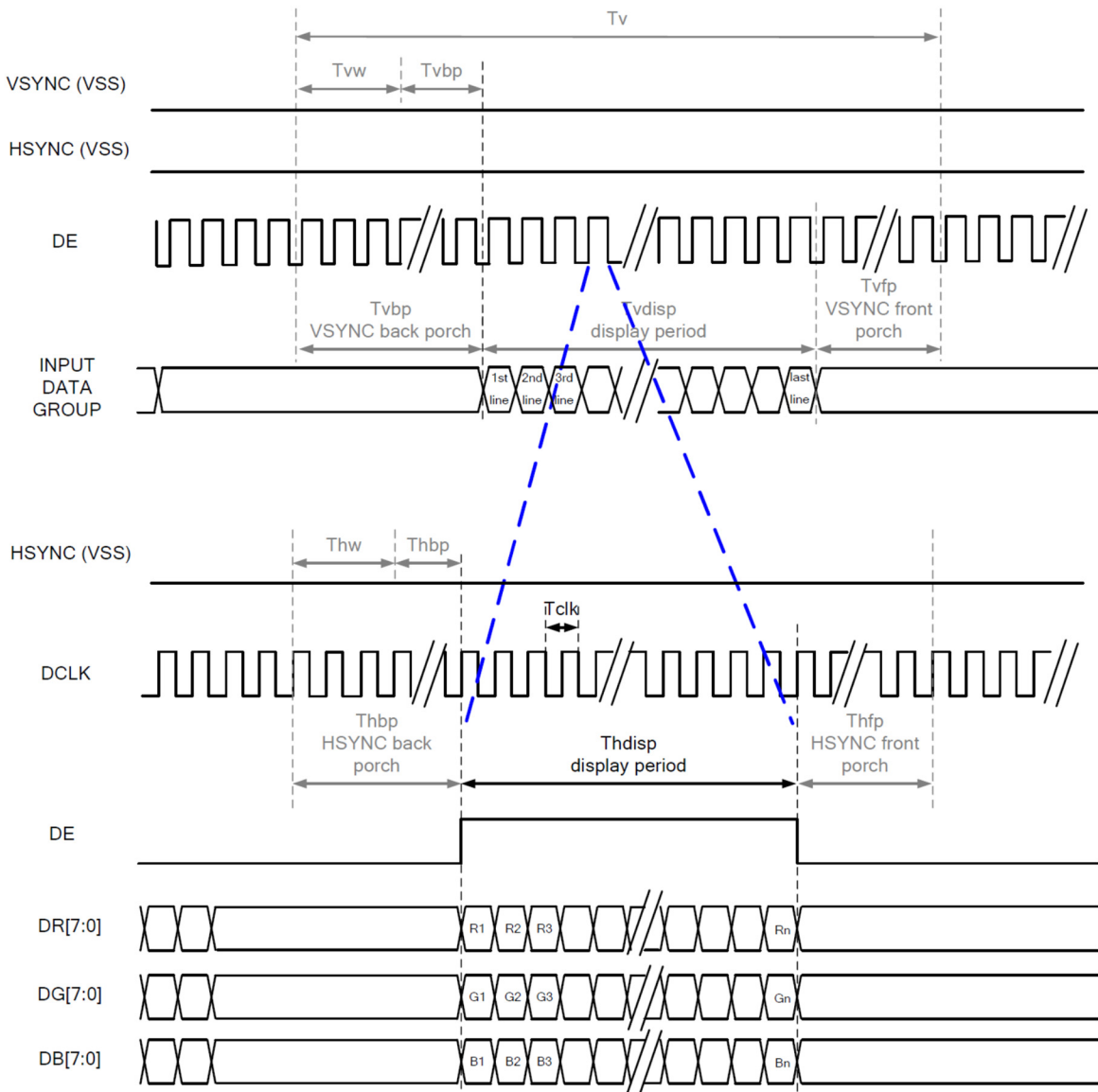

RGB Mode Selection Table	DCLK	HSYNC	VSYNC	DE
SYNC - DE Mode	Input	Input	Input	Input
SYNC Mode	Input	Input	Input	GND
DE Mode	Input	GND	GND	Input

Note: "Input" means these signals are driven by host side.

7.2 Parallel 24 bit RGB Input Timing Table

Parallel 24-bit RGB Input Timing (PVDD=VDD=VDDI= 3.3V, AGND= 0V, TA=25°C)

480RGB X 272 Resolution Timing Table							
Item	Symbol	Min.	Typ.	Max.	Unit	Remark	
DCLK Frequency	Fclk	8	9	12	MHz		
DCLK Period	Tclk	83	111	125	ns		
HSYNC	Period Time	Th	485	531	598	DCLK	
	Display Period	Thdisp		480		DCLK	
	Back Porch	Thbp	3	43	43	DCLK	By H_BLANKING setting
	Front Porch	Thfp	2	8	75	DCLK	
	Pulse Width	Thw	2	4	43	DCLK	
VSYNC	Period Time	Tv	276	292	321	HSYNC	
	Display Period	Tvdisp		272		HSYNC	
	Back Porch	Tvbp	2	12	12	HSYNC	By V_BLANKING setting
	Front Porch	Tvfp	2	8	37	HSYNC	
	Pulse Width	Tvw	2	4	12	HSYNC	

Note: It is necessary to keep Tvbp =12 and Thbp =43 in sync mode. DE mode is unnecessary to keep it.

7.3 Power ON/OFF Sequence

7.3.1 Power On Sequence

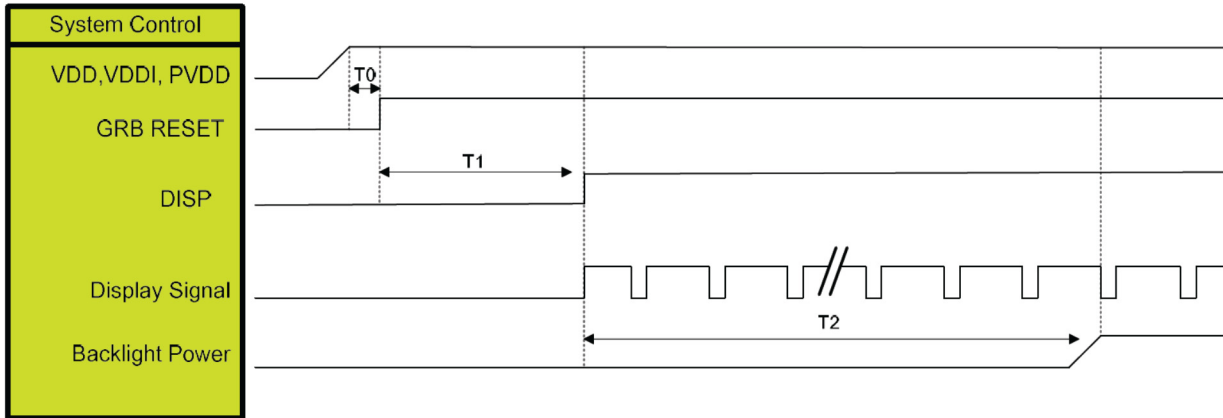

Symbol	Description	Min. Time	Unit
T0	System power stability to GRB RESET signal	0	ms
T1	GRB RESET= "High" to DISP="High"	10	ms
T2	Display Signal output to Backlight Power on	250	ms

7.3.2 Power Off Sequence

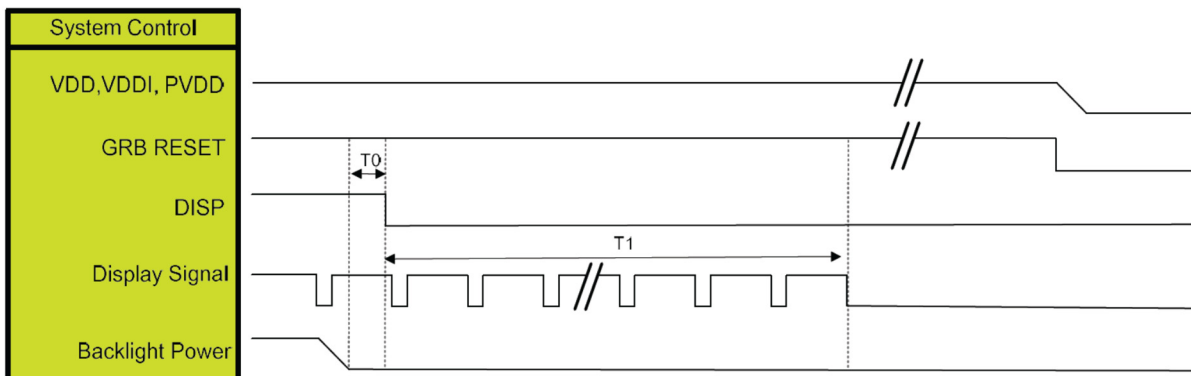

Symbol	Description	Min. Time	Unit
T0	Backlight Power off to DISP="Low"	5	ms
T1	DISP="Low" to IC internal voltage discharge complete	80	ms

8. PCAP TOUCHPANEL

Table 9

Item	Specification	Unit
Touch panel Size	2.8 inches	
Active Area (Sensor)	45.4 (H) x 59.8 (V)	mm
Input type	5 Point multi touch	
Controller	GT911	
Interface mode	I ² C	
Normal mode operating current	typ. 8	mA

TIMING SPECIFICATIONS FOR CTP

I²C Communication

This module provides standard I²C interface for communication. In the system, this module always works in slave mode, all communications are initiated by master, and the baud rate can be up to 400K bps. The definition of I²C timing is as following:

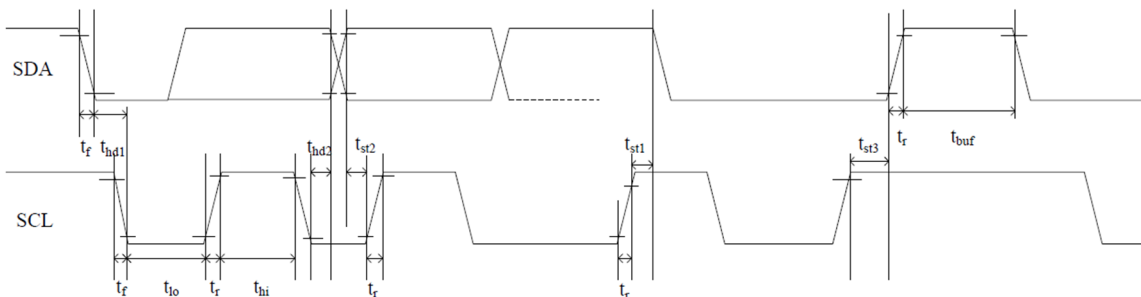

Fig.6 RGB Interface Timing Characteristics

Test condition: 3.3V communication interface, 400Kbps, pull up resistor is 2K ohm

Parameter	Symbol	MIN.	Max.	Unit
SCL low period	t_{lo}	0.9	-	US
SCL high period	t_{hi}	0.8	-	US
SCL setup time for START condition	t_{st1}	0.4	-	US
SCL setup time for STOP condition	t_{st3}	0.4	-	US
SCL hold time for START condition	t_{hd1}	0.3	-	US
SDA setup time	t_{st2}	0.4	-	US
SDA hold time	t_{hd2}	0.4	-	US

This module has 2 sets of slave address 0xBA/0xBB & 0x28/29. Master can control Reset & INT pin to configure the slave address in power on initial state like following:

Power on diagram:

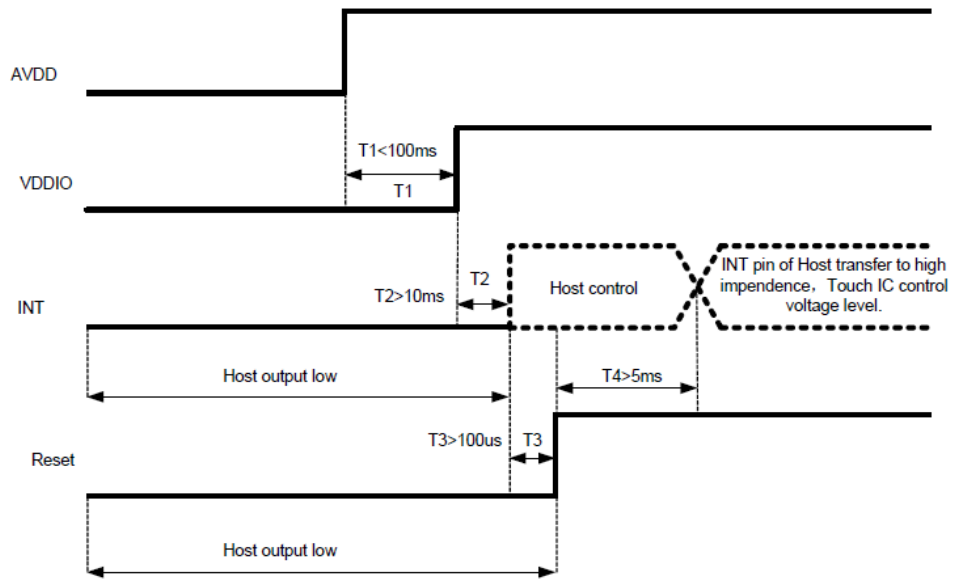

Fig.7 Power on diagram

Timing of setting slave address to 0x28/0x29:

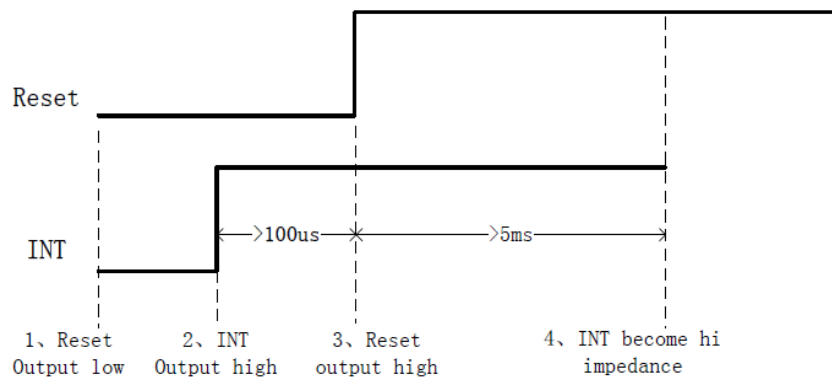

Fig.8(a) Timing of setting slave address

Timing of setting slave address to 0xBA/0xBB:

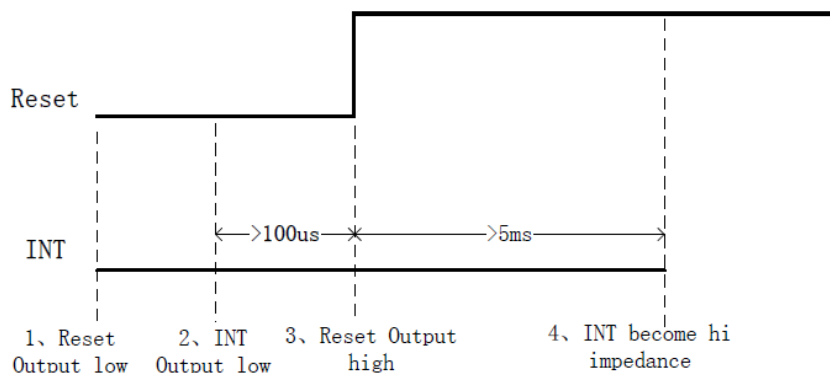

Fig.8(b) Timing of setting slave address

Data Transmission

(ex: slave address is 0xBA/0xBB)

Communication is always initiated by master, A high-to-low transition of SDA with SCL high is a start condition.

All addressing signal are serially transmitted to and from on bus in 8-bit word. This module sends a “0” to acknowledge when the addressing word is 0xBA/BB (or 0x28/0x29). This happens during the ninth clock cycle. If the slave address is not matched, this module will stay in idle state.

The data words are serially transmitted to and from in 9-bit formation: 8-bit data+1-bit ACK or NACK sent by module. Data changes during SCL low periods & keeps valid during SCL high.

A low-to-high transition of SDA with SCL high is a stop condition.

Write Data to module

(ex: slave address is 0xBA/0xBB)

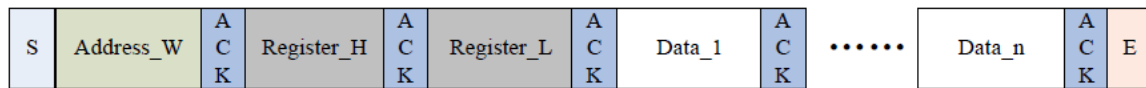

Please check the above figure, master start the communication first, and then sends device address 0xBA preparing for a write operation.

After receiving ACK from module, master sends out 16-bit register address, and then the data word in 8-bit, which is going to be wrote into module.

The address pointer of module will automatically increase one after one byte writing, so master can sequentially write in one operation. When operation finished, master stop the communication.

Read Data from module

(ex: slave address is 0xBA/0xBB)

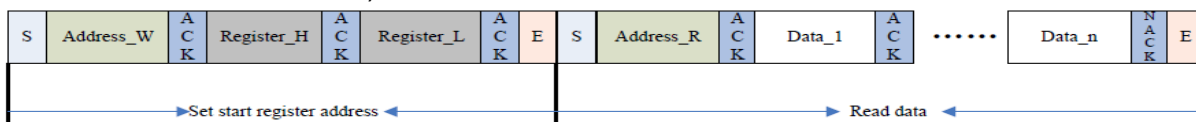

Please check the above figure, master start the communication first, and then sends device address 0xBA for a write operation.

After receiving ACK from module, master sends out 16-bit register address, to set the address pointer of module. After receiving ACK, master produce start signal once again & send device address 0xBB , then read data word from module in 8-bit.

Module also supports sequential read operation, and the default setting is sequential read mode. Master shall send out ACK after every byte reading successfully but NACK after the last one. Then sends stop signal to finish the communication.

REGISTER INFORMATION OF MODULE

a) Real Time Order

(Write Only)

Addr	Name	bit7	bit6	bit5	bit4	bit3	bit2	bit1	bit0
0x8040	Command	0: read coordinate 1: read diff data or raw data 2: software reset3:baseline update 4: baseline calibration 5: screen off 3&4 are still internal test							

b) Configuration Information

(R/W)

	Config Data	bit7	bit6	bit5	bit4	bit3	bit2	bit1	bit0
0x8047	Config_Version	Version of the configuration							
0x8048	X Output Max (Low Byte)	Resolution of X axis							
0x8049	X Output Max (High Byte)								
0x804A	Y Output Max (Low Byte)	Resolution of Y axis							
0x804B	Y Output Max (High Byte)								
0x804C	Touch Number	Reserved				Touch number: 1~5			
0x804D	Module_Switch1	Reserved		Stretch_rank		X2Y	Reserved	INT trigger method 00: rising edge trigger 01: falling edge trigger	

						02: low level enquiry 03: high level enquiry
0x804E	Module_switch2	Reserved				
0x804F	Shake_Count	Reserved		Finger shake count		
0x8050	Filter	First_Filter	Normal_Filter (filtering value of original coordinate window, coefficient is 1)			
0x8051	Large_Touch	Number of touch in large area				
0x8052	Noise_Reduction	Reserved		Value of noise elimination (coefficient is 1, 0~15)		
0x8053	Screen_Touch_Level	Threshold of touch grow out of nothing				
0x8054	Screen_Leave_Level	Threshold of touch grow out of nothing				
0x8055	Low_Power_Control	Reserved		Time to low power consumption (0~15s)		
0x8056	Refresh_Rate	Reserved		Coordinate report rate (Cycle: 5+N ms)		
0x8057	x_threshold	Reserved				
0x8058	y_threshold					
0x8059	X_Speed_Limit	Reserved				
0x805A	Y_Speed_Limit					
0x805B	Space	Blank area of boarder-top (coefficient is 32)		Blank area of Boarder-bottom (coefficient is 32)		
0x805C		Blank area of boarder-left (coefficient is 32)		Blank area of Boarder-right (coefficient is 32)		
0x805D	Stretch_Rate	Reserved		Level of weak stretch (Stretch X/16 Pitch) (beta version is valid, published version is not)		
0x805E	Stretch_R0	Interval 1 coefficient				
0x805F	Stretch_R1	Interval 2 coefficient				
0x8060	Stretch_R2	Interval 3 coefficient				
0x8061	Stretch_RM	All intervals base number				
0x8062	Drv_GroupA_Num	All_Driving	Reserved		Driver_Group_A_number	
0x8063	Drv_GroupB_	Reserved		Driver_Group_B_number		

	Num			
0x8064	Sensor_Num	Sensor_Group_B_Number		Sensor_Group_A_Number
0x8065	FreqA_factor	Driver frequency double frequency coefficient of Driver group A GroupA_Frequency = Multiplier factor * baseband		
0x8066	FreqB_factor	Driver frequency double frequency coefficient of Driver group B GroupB_Frequency = Multiplier factor * baseband		
0x8067	Pannel_BitFreqL	Baseband of Driver group A\B (1526HZ<baseband<14600Hz)		
0x8068	Pannel_BitFreqH			
0x8069	Pannel_Sensor_TimeL	Time interval of the neighbouring two driving signal (Unit: us), Reserved.		
0x806A	Pannel_Sensor_TimeH			
0x806B	Pannel_Tx_Gain	Reserved		Pannel_Drv_output_R 4 gears Pannel_DAC_Gain 0:Gain maximum 7: Gain minimum
0x806C	Pannel_Rx_Gain	Pannel_PG_A_C	Pannel_PGA_R	Pannel_Rx_Vcml (4 gears) Pannel_PGA_Gain (8 gears)
0x806D	Pannel_Dump_Shift	Reserved		Magnification coefficient of original value (The Nth power of 2)
0x806E	Drv_Frame_Control	Reserved	SubFrame_DrvNum	
0x806F	NC	Reserved		
0x8070	NC	Reserved		
0x8071	NC	Reserved		
0x8072	Stylus_Tx_Gain	Undefined (invalid when stylus_priority=0)		
0x8073	Stylus_Rx_Gain	Undefined (invalid when stylus_priority=0)		
0x8074	Stylus_Dump_Shift	Magnification coefficient of original value (The Nth power of 2), Reserved		
0x8075	Stylus_Driver_Touch_Level	Stylus effective threshold (driving), Reserved		
0x8076	Stylus_Sensor_Touch_Level	Stylus effective threshold (sensing), Reserved		
0x8077	Stylus_Control	Pen mode escape time out period (Unit: Sec)		
0x8078	Base_reduce	S-Style improve quantity		Reserved
0x8079	NC	Reserved		

0x807A	Freq_Hopping_Start	Frequency hopping start frequency (Unit: 2KHz, 50 means 100KHz)		
0x807B	Freq_Hopping_End	Frequency hopping stop frequency (Unit: 2KHz, 150 means 300KHz)		
0x807C	Noise_Detect_Times	Detect_Stay_Times	Detect_Confirm_Times	
0x807D	Hopping_Flag	Hopping_En	Reserved	Detect_Time_Out
0x807E	Hopping_Threshold	Large_Noise_Threshold		Hopping_Hit_Threshold
0x807F	Noise_Threshold	Threshold of noise level		
0x8080	NC	Reserved		
0x8081	NC	Reserved		
0x8082	Hopping_seg1_BitFreqL	Frequency hopping segment band 1 central frequency (for driver A/B)		
0x8083	Hopping_seg1_BitFreqH			
0x8084	Hopping_seg1_Factor	Frequency hopping segment 1 central frequency coefficient		
0x8085	Hopping_seg2_BitFreqL	Frequency hopping segment band 2 central frequency (for driver A/B)		
0x8086	Hopping_seg2_BitFreqH			
0x8087	Hopping_seg2_Factor	Frequency hopping segment 2 central frequency coefficient		
0x8088	Hopping_seg3_BitFreqL	Frequency hopping segment band 3 central frequency (for driver A/B)		
0x8089	Hopping_seg3_BitFreqH			
0x808A	Hopping_seg3_Factor	Frequency hopping segment 3 central frequency coefficient		
0x808B	Hopping_seg4_BitFreqL	Frequency hopping segment band 4 central frequency (for driver A/B)		
0x808C	Hopping_seg4_			

	BitFreqH		
0x808D	Hopping_seg4_Factor	Frequency hopping segment 4 central frequency coefficient	
0x808E	Hopping_seg5_BitFreqL	Frequency hopping segment band 5 central frequency (for driver A/B)	
0x808F	Hopping_seg5_BitFreqH		
0x8090	Hopping_seg5_Factor	Frequency hopping segment 5 central frequency coefficient	
0x8091	NC	Reserved	
0x8092	NC	Reserved	
0x8093	Key 1	Key 1 Position: 0-255 valid (0 means no touch, it means independent touch key when 4 of the keys are 8 multiples)	
0x8094	Key 2	Key 2 position	
0x8095	Key 3	Key 3 position	
0x8096	Key 4	Key 4 position	
0x8097	Key_Area	Time limit for long press(1~16 s)	Touch valid interval setting: 0-15 valid
0x8098	Key_Touch_Level	Key threshold of touch key	
0x8099	Key_Leave_Level	Key threshold of touch key	
0x809A	Key_Sens	KeySens_1(sensitivity coefficient of key 1, same below)	KeySens_2
0x809B	Key_Sens	KeySens_3	KeySens_4
0x809C	Key_Restrain	Finger from screen left after inhibition of key time(Unit:100ms,0 means 600ms)	The independent button pro key inhibition parameters
0x809D	NC	Reserved	
0x809E	NC	Reserved	
0x809F	NC	Reserved	
0x80A0	NC	Reserved	
0x80A1	NC	Reserved	
0x80A2	Proximity_Drv_Select	Drv_Start_Ch (start channel of driving direction)	Drv_End_Ch (End channel)
0x80A3	Proximity_Sens_Select	Sens_Start_Ch (start channel of sensing direction)	Sens_End_Ch (End channel)
0x80A4	Proximity_Touch_Level	Proximity effective threshold value	
0x80A5	Proximity_Leave_Level	Proximity ineffective threshold value	

0x80A6	Proximity_Sample_Add_Times	Frequency multiplication of proximity sensing channel.
0x80A7	Proximity_Sample_Dec_ValL	Sample value minus this value (16 bit), and accumulate, low byte.
0x80A8	Proximity_Sample_Dec_ValH	Sample value minus this value (16 bit), and accumulate, high byte.
0x80A9	Proximity_Leave_Shake_Count	exit proximity jitter count
0x80AA	Self_Cap_Tx_gain	self-capacitance sends gains
0x80AB	Self_Cap_Rx_gain	self-capacitance receive gains
0x80AC	Self_Cap_Dump_Shift	Magnification coefficient of original value of self-capacitance (The Nth power of 2)
0x80AD	SCap_Diff_Up_Level_Drv	Self capacitance suppress floating rising threshold (driving direction)
0x80AE	Scap_Merge_Touch_Level_Drv	Self-capacitance Touch Level (driving direction)
0x80AF	SCap_Pulse_TimeL	Self-capacitance sampling time (low byte)
0x80B0	SCap_Pulse_TimeH	Self-capacitance sampling time (high byte)
0x80B1	SCap_Diff_Up_Level_Sen	Self capacitance suppress floating rising threshold (sensing direction)
0x80B2	Scap_Merge_Touch_Level_Sen	Self-capacitance Touch Level (sensing direction)
0x80B3	NC	Reserved
0x80B4	NC	Reserved
0x80B5	NC	Reserved
0x80B6	NC	Reserved
0x80B7 ~ 0x80C4	Sensor_CH0~ Sensor_CH13	ITO Sensor corresponding chip channel number
0x80C5 ~ 0x80D4	NC	Reserved
0x80D5 ~ 0x80EE	Driver_CH0~ Driver_CH25	ITO Driver corresponding chip channel number
0x80EF ~	NC	Reserved

0x80FE		
0x80FF	Config_Chksum	configuration information verify (the complement number of total byte from 0x8047 to 0x80FE)
0x8100	Config_Fresh	signal of updated configuration (the host writes)

c) Coordinates Information

Addr	Access	bit7	bit6	bit5	bit4	bit3	bit2	bit1	bit0
0x8140	R	Product ID (first byte, ASCII)							
0x8141	R	Product ID (second byte, ASCII)							
0x8142	R	Product ID (third byte, ASCII)							
0x8143	R	Product ID (forth byte, ASCII)							
0x8144	R	Firmware version (HEX.low byte)							
0x8145	R	Firmware version (HEX.high byte)							
0x8146	R	x coordinate resolution (low byte)							
0x8147	R	x coordinate resolution (high byte)							
0x8148	R	y coordinate resolution (low byte)							
0x8149	R	y coordinate resolution (high byte)							
0x814A	R	Vendor_id (current module option information)							
0x814B	R	Reserved							
0x814C	R	Reserved							
0x814D	R	Reserved							
0x814E	R/W	buffer status	large detect	Reserved			number of touch points		
0x814F	R	track id							
0x8150	R	point 1 x coordinate (low byte)							
0x8151	R	point 1 x coordinate (high byte)							
0x8152	R	point 1 y coordinate (low byte)							
0x8153	R	point 1 y coordinate (high byte)							
0x8154	R	Point 1 size (low byte)							
0x8155	R	point 1 size (high byte)							
0x8156	R	Reserved							
0x8157	R	track id							
0x8158	R	point 2 x coordinate (low byte)							
0x8159	R	point 2 x coordinate (high byte)							
0x815A	R	point 2 y coordinate (low byte)							
0x815B	R	point 2 y coordinate (high byte)							
0x815C	R	point 2 size (low byte)							
0x815D	R	point 2 size (high byte)							
0x815E	R	Reserved							

0x815F	R	track id
0x8160	R	point 3 x coordinate (low byte)
0x8161	R	point 3 x coordinate (high byte)
0x8162	R	point 3 y coordinate (low byte)
0x8163	R	point 3 y coordinate (high byte)
0x8164	R	point 3 size (low byte)
0x8165	R	point 3 size (high byte)
0x8166	R	Reserved
0x8167	R	track id
0x8168	R	point 4 x coordinate (low byte)
0x8169	R	point 4 x coordinate (high byte)
0x816A	R	point 4 y coordinate (low byte)
0x816B	R	point 4 y coordinate (high byte)
0x816C	R	point 4 size (low byte)
0x816D	R	point 4 size (high byte)
0x816E	R	Reserved
0x816F	R	track id
0x8170	R	point 5 x coordinate (low byte)
0x8171	R	point 5 x coordinate (high byte)
0x8172	R	point 5 y coordinate (low byte)
0x8173	R	point 5 y coordinate (high byte)
0x8174	R	point 5 size (low byte)
0x8175	R	point 5 size (high byte)
0x8176	R	Reserved
0x8177	R	Reserved

FUNCTION MODE

Working Mode

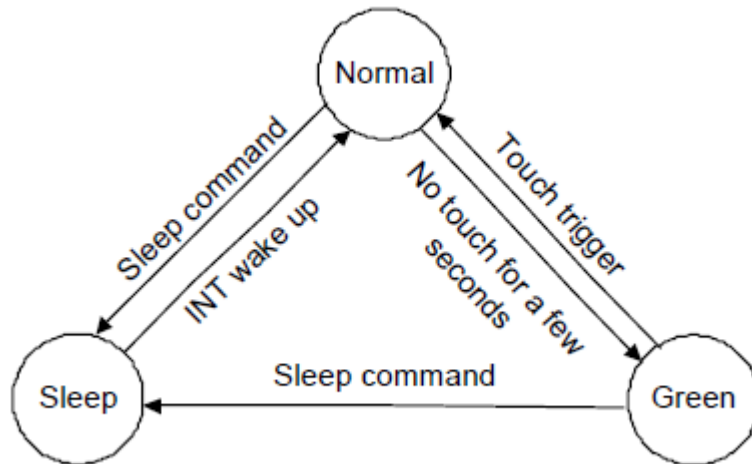

a) Normal Mode

When module is in Normal mode, touch scanning period is about 7ms ~ 10ms depending on the setting. The chip will automatically enter into Green mode if no touch for short time within 0~15s depending on setting and the step is 1s.

b) Green Mode

In Green mode, the touch scanning cycle is fixed as 40ms. It will automatically enter into Normal mode if any touch is detected.

c) Sleep Mode

For a lower consumption, Master can ask module to enter Sleep mode through I2C command (before the command, please drive low to INT pin). Drive high to the INT pin of module 2~5ms will make module return back to normal mode.

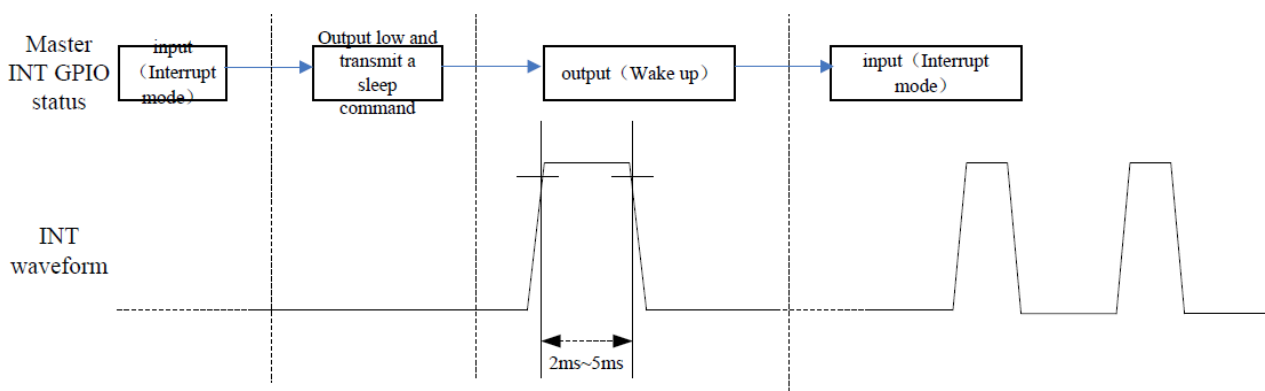

Pulse Calling

Module will inform master to read coordinate information only when touch event happen, in order to lighten the burden of master CPU. The master CPU will set trigger mode by register "INT". "0" means rising edge trigger, in this mode module will output a rising edge hopping in INT, to inform CPU; "1" means falling edge trigger.

Sleep Mode

When the display is turned off or in any circumstance that operation of touch panel is not necessary, master can set module be in Sleep mode through I2C command. The master can wake up module by outputting high to INT pin & keeping 2-5ms.

Frequency Hopping Function

This module has very strong anti-interference hardware, when the driver spectrum of module overlaid with spectrum of noise signal, it can be switch to another frequency by self-adaption frequency hopping mechanism, to avoid interference.

Automatic Calibration

a) Initialization Calibration

Different temperature, humidity and physical structure will affect the sensor's baseline. According to environmental situation module will update the baseline automatically in initialized 200ms.

b) Automatic Temperature Drift

Slow change of temperature, humidity or dust and other environmental factors will also affect the sensor's baseline. module calculates and analyses historical data, and compare to the current data variation. Base on this, the baseline will be calibration automatically.

For more information, refer to the data sheet GT911:

https://www.lcd-module.de/fileadmin/eng/pdf/zubehoer/GT911%20Datasheet_English%2020150625_Rev10.pdf

9. Outline Dimension

9.1 EA R480X-43ALW

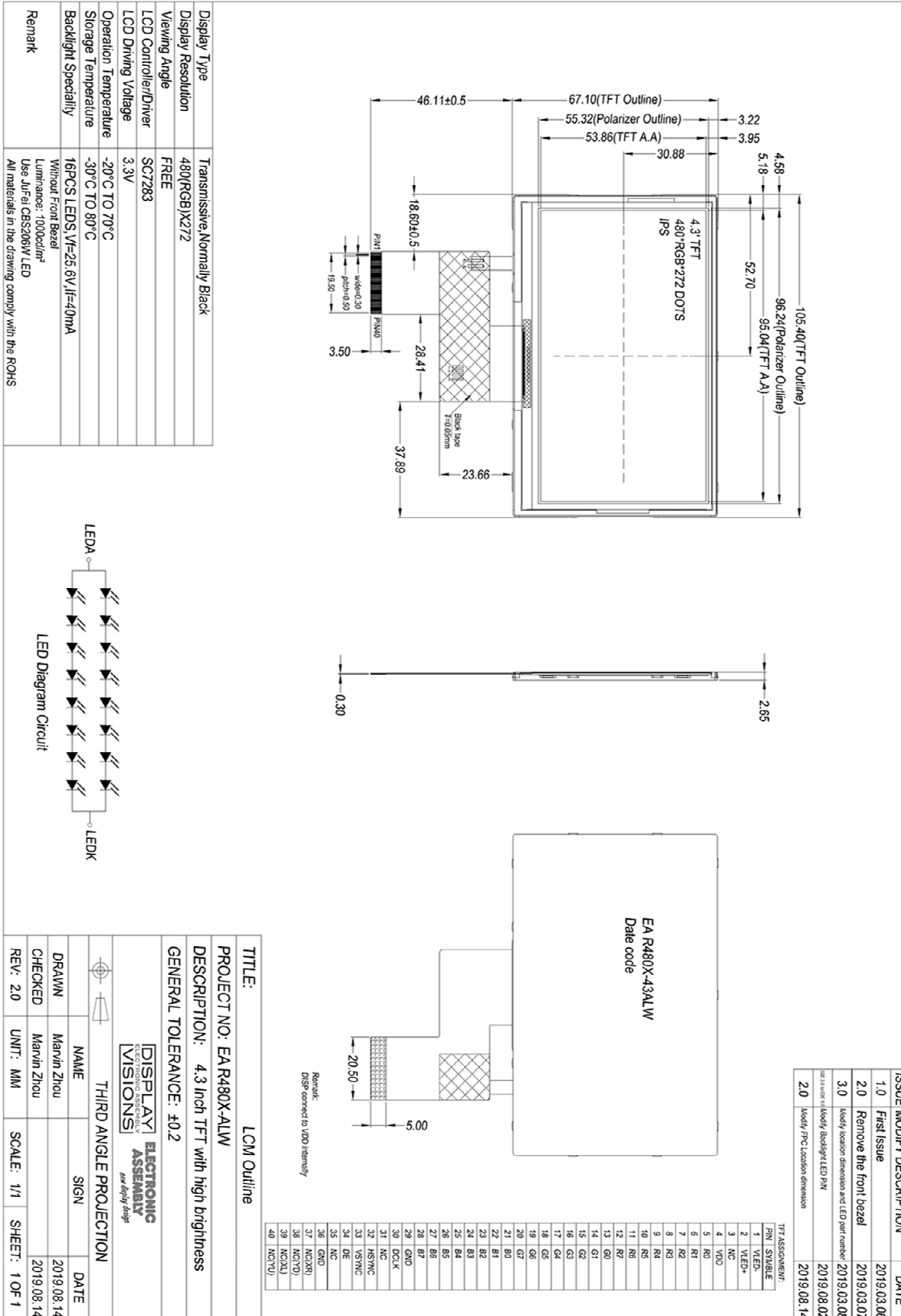

10. Reliability and Inspection Standard

No.	Test Item		Test Conditions	Remark
1	High Temperature	Storage	80°C, 120Hr	Note
		Operation	70°C, 120Hr	Note
2	Low Temperature	Storage	-30°C, 120Hr	Note
		Operation	-20°C, 120Hr	
3	High Temperature and High Humidity		40°C, 90%RH, 120Hr	Note
4	Thermal Cycling Test(No operation)		-20C for 30min, 70c for 30 min. 100 cycles. Then test at room temperature after 1 hour	Note
5	Vibration Test(No operation)		Frequency :10~55 HZ; Stroke :1.5 mm;Sweep:10HZ~55HZ~10HZ; 2hours for each direction of X, Y, Z(6 hours for total)	
6	Package Drop Test		Height:60 cm,1 corner, 3 edges, 6 surfaces	
7	Electro Static Discharge		±2KV,Human Body Mode, 100pF/1500Ω	

Note:

- 1) Sample quantity for each test item is 5~10pcs.
- 2) Note 4: Before cosmetic and function test, the product must have enough recovery time, at least 2 hours at room temperature.

11.PRECAUTIONS FOR USING LCD MODULES

Handing Precautions

- (1) The display panel is made of glass and polarizer. As glass is fragile, it tends to become or chipped during handling especially on the edges. Please avoid dropping or jarring. Do not subject it to a mechanical shock by dropping it or impact.
- (2) If the display panel is damaged and the liquid crystal substance leaks out, be sure not to get any in your mouth. If the substance contacts your skin or clothes, wash it off using soap and water.
- (3) Do not apply excessive force to the display surface or the adjoining areas since this may cause the color tone to vary. Do not touch the display with bare hands. This will stain the display area and degraded insulation between terminals (some cosmetics are determined to the polarizer).
- (4) The polarizer covering the display surface of the LCD module is soft and easily scratched. Handle this polarizer carefully. Do not touch, push or rub the exposed polarizers with anything harder than an HB pencil lead (glass, tweezers, etc.). Do not put or attach anything on the display area to avoid leaving marks on. Condensation on the surface and contact with terminals due to cold will damage, stain or dirty the polarizer. After products are tested at low temperature they must be warmed up in a container before coming is contacting with room temperature air.
- (5) If the display surface becomes contaminated, breathe on the surface and gently wipe it with a soft dry cloth. If it is heavily contaminated, moisten cloth with one of the following solvents
 - Isopropyl alcohol
 - Ethyl alcoholDo not scrub hard to avoid damaging the display surface.
- (6) Solvents other than those above-mentioned may damage the polarizer. Especially, do not use the following.
 - Water
 - Ketone
 - Aromatic solventsWipe off saliva or water drops immediately, contact with water over a long period of time may cause deformation or color fading. Avoid contacting oil and fats.
- (7) Exercise care to minimize corrosion of the electrode. Corrosion of the electrodes is accelerated by water droplets, moisture condensation or a current flow in a high-humidity environment.
- (8) Install the LCD Module by using the mounting holes. When mounting the LCD module make sure it is free of twisting, warping and distortion. In particular, do not forcibly pull or bend the I/O cable or the backlight cable.
- (9) Do not attempt to disassemble or process the LCD module.
- (10) NC terminal should be open. Do not connect anything.
- (11) If the logic circuit power is off, do not apply the input signals.
- (12) Since LCM has been assembled and adjusted with a high degree of precision, avoid applying excessive shocks to the module or making any alterations or modifications to it.
 - Do not alter, modify or change the shape of the tab on the metal frame.

- Do not make extra holes on the printed circuit board, modify its shape or change the positions of components to be attached.
- Do not damage or modify the pattern writing on the printed circuit board.
- Absolutely do not modify the zebra rubber strip (conductive rubber) or heat seal connector.
- Except for soldering the interface, do not make any alterations or modifications with a soldering iron.
- Do not drop, bend or twist LCM.

Storage Precautions

When storing the LCD modules, the following precaution is necessary.

- (1) Store them in a sealed polyethylene bag. If properly sealed, there is no need for the desiccant.
- (2) Store them in a dark place. Do not expose to sunlight or fluorescent light, keep the temperature between 0°C and 35°C.
- (3) The polarizer surface should not come in contact with any other objects. (We advise you to store them in the container in which they were shipped).

Others

Liquid crystals solidify under low temperature (below the storage temperature range) leading to defective orientation or the generation of air bubbles (black or white). Air bubbles may also be generated if the module is subject to a low temperature.

If the LCD modules have been operating for a long time showing the same display patterns, the display patterns may remain on the screen as ghost images and a slight contrast irregularity may also appear. A normal operating status can be regained by suspending use for some time. It should be noted that this phenomenon does not adversely affect performance reliability. To minimize the performance degradation of the LCD modules resulting from destruction caused by static electricity etc., exercise care to avoid holding the following sections when handling the modules.

- Exposed area of the printed circuit board.
- Terminal electrode sections.

X-ON Electronics

Largest Supplier of Electrical and Electronic Components

Click to view similar products for [TFT Displays & Accessories](#) category:

Click to view products by [Electronic Assembly](#) manufacturer:

Other Similar products are found below :

[F3ET2-005-150](#) [HDA430T-3G1H](#) [NB7W-KBA04](#) [NB-ATT01](#) [NB5Q-ATT01](#) [NB5Q-KBA04](#) [NB-CN001](#) [OAI-80038AA-2008-A](#) [315-U004B15300](#) [TCG121WXLRXVNNANX35](#) [EIC-LCD-1080P](#) [T-55619GD065J-LW-ABN](#) [NLB150XG02L-01](#) [NL192108AC10-01D](#) [NL6448AC18-08F](#) [NL8060BC26-35BA](#) [NL6448BC26-26D](#) [NL8060BC31-50F](#) [TM070DDHG03-40](#) [PTPW16-070WV1S02](#) [PTPW16-084SV1S02](#) [MTD0300ECP06DF-1](#) [4DLCD-35480320-CTP-IPS](#) [4DLCD-35480320-IPS](#) [4DLCD-35480320-RTP-IPS](#) [4DLCD-50800480-CTP-IPS](#) [RFA6400E-AWH-DNG](#) [RFE430V-AZW-DNS](#) [RFF70BQ-1IW-DBG](#) [RFF70VA2-1IW-DHS](#) [RFH700A8-AYH-MNN](#) [RFK101VF-1YH-LHG](#) [RFS52VA-1ZH-DHN](#) [SM-RVT101HVHFWN00](#) [SM-RVT101HVHNWC00](#) [SM-RVT101HVHNWCA0](#) [SM-RVT101HVHNWN00](#) [SM-RVT101HVLFWCA0](#) [SM-RVT101HVLNWCA0](#) [SM-RVT35HHTFWCA0](#) [SM-RVT35HHTNWCA0](#) [SM-RVT43HLTFWCA0](#) [SM-RVT43HLTNWCA0](#) [SM-RVT50HQTFWCA0](#) [SM-RVT50HQTNWCA0](#) [SM-RVT70AQLFWR00](#) [SM-RVT70AQLNWR00](#) [SM-RVT70HSLFWCA0](#) [SM-RVT70HSMFWCA0](#) [SM-RVT70HSMFWN00](#)