

Side thrust pins

with thread

SPECIFICATION

Types

- Type **SB**: thrust pin Steel, with seal
 - Type **SA***: thrust pin Steel, without seal
- * not available from stock, requires a minimum order quantity

Housing Steel
zinc plated, blue passivated

Thrust pin Steel, hardened
zinc plated, blue passivated

Thrust spring coding
Force low thrust: grey
medium thrust: black
high thrust: silver

Seal rubber
NBR (Perbunan)



INFORMATION

Spring loaded side thrust pins GN 713 are versatile and practical elements for holding, positioning and clamping workpieces. They eliminate costly alternatives, are space saving and simple to install. The protruding height of the thrust pin can be adjusted with the threaded body.
For easy mounting a suitable tool GN 713.1 is available (see table).

ACCESSORY

- Mounting tools GN 713.1 (Code no. see table)

TECHNICAL INFORMATION

- Elastomer characteristics (see page A32)

TECHNICAL AND ASSEMBLY INSTRUCTIONS

w = Movement of pin
F = Side thrust in N
initial thrust = F_0
end thrust = $1.1 \times F_0$
 $a_2 - a_1$ = Clamping range for workpiece
x = Distance centre line – thrust point at w
 x_1 for highest thrust point (a_1)
 x_2 for lowest thrust point (a_2)
 l_0 = Distance end stop – bore of thrust bush
 $l_0 = l_m + x$
 l_m = Average length of workpiece $l_{max.} + l_{min.} / 2$
For contact points (workpiece height) between a_1 and a_2 a value for x has to be used lying between x_1 and x_2 (interpolation).

By observing the above values the full movement of the side thrust pin will be available to cover the tolerance of the workpiece.

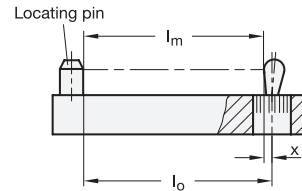

For inserting the side thrust pins the use of a mounting tool GN 715.1 or spanner GN 713.1 is recommended.

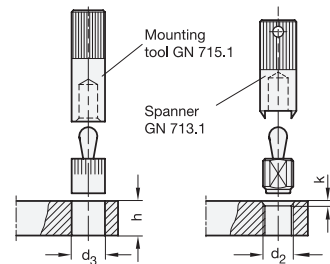

Eccentric bushes GN 715.2 (see page 867) are tooling accessory for GN 714 (see page 862) / GN 715 (see page 860). They enable a precise optimum setting of side thrust pins. This allows an adjustment to l_0 to accommodate for instance a larger tolerance range on a workpiece.

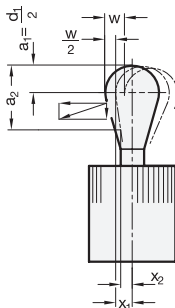
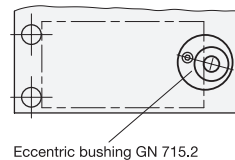

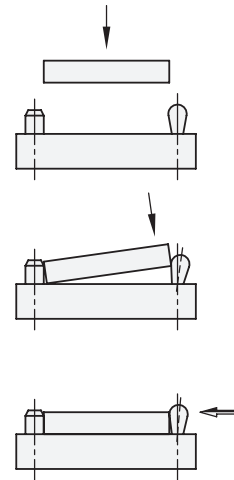
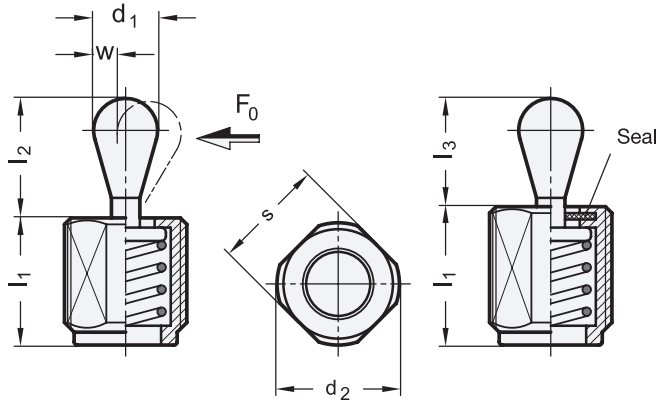

* Complete with type index of the Side thrust pins (SB or SA)
 SB SA



GN 713

Description	d1	Side thrust F0 in N at l2	l1 -1.5	d2	a1	a2	k	l2	l3	s	w	x1	x2	Code no. for mounting tool	⚖️
GN 713-5-20-11.5-*	5	20	11.5	M 12	2.5	5.7	1.5x45°	6.7	6	10	1.6	1.7	1.3	GN 713.1-5.6	4
GN 713-5-20-19-*	5	20	19	M 12	2.5	5.7	1.5x45°	6.7	6	10	1.6	1.7	1.3	GN 713.1-5.6	6
GN 713-5-20-26.5-*	5	20	26.5**	M 12	2.5	5.7	1.5x45°	6.7	6	10	1.6	1.7	1.3	GN 713.1-5.6	8
GN 713-5-50-11.5-*	5	50	11.5	M 12	2.5	5.7	1.5x45°	6.7	6	10	1.6	1.7	1.3	GN 713.1-5.6	4
GN 713-5-50-19-*	5	50	19	M 12	2.5	5.7	1.5x45°	6.7	6	10	1.6	1.7	1.3	GN 713.1-5.6	6
GN 713-5-50-26.5-*	5	50	26.5**	M 12	2.5	5.7	1.5x45°	6.7	6	10	1.6	1.7	1.3	GN 713.1-5.6	8
GN 713-5-100-11.5-*	5	100	11.5	M 12	2.5	5.7	1.5x45°	6.7	6	10	1.6	1.7	1.3	GN 713.1-5.6	4
GN 713-5-100-19-*	5	100	19	M 12	2.5	5.7	1.5x45°	6.7	6	10	1.6	1.7	1.3	GN 713.1-5.6	7
GN 713-5-100-26.5-*	5	100	26.5**	M 12	2.5	5.7	1.5x45°	6.7	6	10	1.6	1.7	1.3	GN 713.1-5.6	9
GN 713-6-40-11.5-*	6	40	11.5	M 12	3	7.7	1.5x45°	10.7	10	10	1.8	1.9	1.4	GN 713.1-5.6	5
GN 713-6-40-19-*	6	40	19	M 12	3	7.7	1.5x45°	10.7	10	10	1.8	1.9	1.4	GN 713.1-5.6	7
GN 713-6-40-26.5-*	6	40	26.5**	M 12	3	7.7	1.5x45°	10.7	10	10	1.8	1.9	1.4	GN 713.1-5.6	8
GN 713-6-75-11.5-*	6	75	11.5	M 12	3	7.7	1.5x45°	10.7	10	10	1.8	1.9	1.4	GN 713.1-5.6	5
GN 713-6-75-19-*	6	75	19	M 12	3	7.7	1.5x45°	10.7	10	10	1.8	1.9	1.4	GN 713.1-5.6	7
GN 713-6-75-26.5-*	6	75	26.5**	M 12	3	7.7	1.5x45°	10.7	10	10	1.8	1.9	1.4	GN 713.1-5.6	9
GN 713-6-150-11.5-*	6	150	11.5	M 12	3	7.7	1.5x45°	10.7	10	10	1.8	1.9	1.4	GN 713.1-5.6	7
GN 713-6-150-19-*	6	150	19	M 12	3	7.7	1.5x45°	10.7	10	10	1.8	1.9	1.4	GN 713.1-5.6	8
GN 713-6-150-26.5-*	6	150	26.5**	M 12	3	7.7	1.5x45°	10.7	10	10	1.8	1.9	1.4	GN 713.1-5.6	10
GN 713-10-100-18-*	10	100	18	M 18 x 1.5	5	10.7	2x45°	16.7	16	16	3.2	3.4	2.7	GN 713.1-10	19
GN 713-10-100-31.5-*	10	100	31.5	M 18 x 1.5	5	10.7	2x45°	16.7	16	16	3.2	3.4	2.7	GN 713.1-10	28
GN 713-10-100-45-*	10	100	45**	M 18 x 1.5	5	10.7	2x45°	16.7	16	16	3.2	3.4	2.7	GN 713.1-10	36
GN 713-10-200-18-*	10	200	18	M 18 x 1.5	5	10.7	2x45°	16.7	16	16	3.2	3.4	2.7	GN 713.1-10	20
GN 713-10-200-31.5-*	10	200	31.5	M 18 x 1.5	5	10.7	2x45°	16.7	16	16	3.2	3.4	2.7	GN 713.1-10	29
GN 713-10-200-45-*	10	200	45**	M 18 x 1.5	5	10.7	2x45°	16.7	16	16	3.2	3.4	2.7	GN 713.1-10	40
GN 713-10-300-18-*	10	300	18	M 18 x 1.5	5	10.7	2x45°	16.7	16	16	3.2	3.4	2.7	GN 713.1-10	21
GN 713-10-300-31.5-*	10	300	31.5	M 18 x 1.5	5	10.7	2x45°	16.7	16	16	3.2	3.4	2.7	GN 713.1-10	30
GN 713-10-300-45-*	10	300	45**	M 18 x 1.5	5	10.7	2x45°	16.7	16	16	3.2	3.4	2.7	GN 713.1-10	38

** not available from stock, requires a minimum order quantity



Indexing elements

X-ON Electronics

Largest Supplier of Electrical and Electronic Components

Click to view similar products for [Terminal Block Tools & Accessories](#) category:

Click to view products by [Elesa & Ganter](#) manufacturer:

Other Similar products are found below :

[1029563](#) [00171430102](#) [00171420102](#) [014415](#) [CSTSPC1-2](#) [9-1437653-4](#) [928358-1](#) [QC209/J](#) [HCL10-6](#) [1437403-6](#) [1437403-9](#) [1437403-8](#)
[147832-1](#) [MT2/H--](#) [MT2/H-32](#) [MT6/H-N](#) [MT6/V-GRND](#) [BB2-09BF](#) [EP2.5/4UN/BG](#) [1707755](#) [1735590](#) [1755480](#) [BO3-02](#) [1789281](#)
[1840227](#) [1840230](#) [1893164](#) [2-1437402-1](#) [2-1437644-9](#) [JB2-09/J](#) [2202307](#) [2302463](#) [2305949](#) [8TK2-24](#) [91.201.1](#) [L2U2](#) [2778.0](#) [2890137](#)
[2901107](#) [2901123](#) [2901699](#) [LFS13003Z](#) [2MP/J](#) [2MV-06](#) [1756294](#) [F03-25](#) [1810532](#) [F505/J](#) [1933011](#) [AMMC-6](#)