

105°C Use, Miniature, High-Reliability, Low Impedance Capacitors Series RJB

- Smaller and higher ripple current than RJJ and RJH Series.
- Guarantees 5000 hours at 105°C.  
(ø 5 to 6.3: 2000 hours ; ø 8 to 10: 3000 hours)

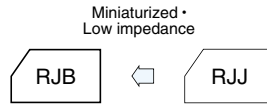

Marking color : White print on a black sleeve  
White print on a brown sleeve

Specifications

Item	Performance																		
Category temperature range (°C)	-55 to +105																		
Tolerance at rated capacitance (%)	±20 (20°C, 120Hz)																		
Leakage current (µA)	Less than 0.01CV + 2 (after 2 minutes) C: Rated capacitance(µF); V: Rated voltage(V) (20°C)																		
Tangent of loss angle (tanδ)	<table border="1"> <tr> <td>Rated voltage (V)</td> <td>6.3</td> <td>10</td> <td>16</td> <td>25</td> <td>35</td> <td>50</td> <td>63</td> <td>100</td> </tr> <tr> <td>tanδ (max.)</td> <td>0.22</td> <td>0.19</td> <td>0.16</td> <td>0.14</td> <td>0.12</td> <td>0.10</td> <td>0.08</td> <td>0.07</td> </tr> </table>	Rated voltage (V)	6.3	10	16	25	35	50	63	100	tanδ (max.)	0.22	0.19	0.16	0.14	0.12	0.10	0.08	0.07
	Rated voltage (V)	6.3	10	16	25	35	50	63	100										
tanδ (max.)	0.22	0.19	0.16	0.14	0.12	0.10	0.08	0.07											
0.02 is added to every 1000µF increase over 1000µF. (20°C, 120Hz)																			
Characteristics at high and low temperature	<table border="1"> <tr> <td>Rated voltage (V)</td> <td>6.3</td> <td>10</td> <td>16</td> <td>25</td> <td>35</td> <td>50</td> <td>63</td> <td>100</td> </tr> <tr> <td>Impedance ratio (max.)</td> <td>Z-55°C / Z+20°C</td> <td>3</td> <td>3</td> <td>3</td> <td>3</td> <td>3</td> <td>3</td> <td>3</td> </tr> </table>	Rated voltage (V)	6.3	10	16	25	35	50	63	100	Impedance ratio (max.)	Z-55°C / Z+20°C	3	3	3	3	3	3	3
	Rated voltage (V)	6.3	10	16	25	35	50	63	100										
Impedance ratio (max.)	Z-55°C / Z+20°C	3	3	3	3	3	3	3											
(120Hz)																			
Endurance (105°C) (Applied ripple current)	Test time	5000 hours (ø 5 to 6.3: 2000 hours) (ø 8 to 10 : 3000 hours)																	
	Leakage current	The initial specified value or less																	
	Percentage of capacitance change	Within ±20% of initial value																	
	Tangent of the loss angle	200% or less of the initial specified value																	
Shelf life (105°C)	Test time	1000 hours																	
	Leakage current	The initial specified value or less																	
	Percentage of capacitance change	Within ±15% of initial value																	
	Tangent of the loss angle	150% or less of the initial specified value																	
Voltage application treatment																			
Applicable standards	JIS C5101-1, -4 1998 (IEC 60384-1 1992, -4 1985)																		

Outline Drawing

Unit: mm

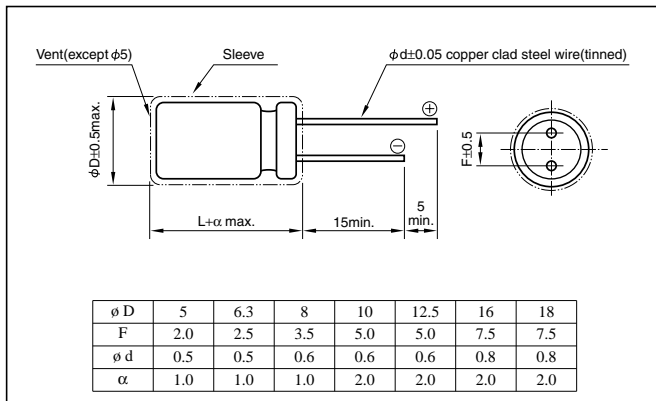

- The electric characteristics are described on page 106.

Coefficient of Frequency for Rated Ripple Current

Rated capacitance(µF)	Frequency(Hz)			
	120	1k	10k	100k
0.47 to 180	0.40	0.75	0.90	1
220 to 390	0.50	0.85	0.95	1
470 to 1800	0.60	0.88	0.96	1
2200 to 3900	0.75	0.90	0.98	1
4700 to 10000	0.85	0.95	1	1

Part numbering system (example: 10V1000µF)

Environmental item	RJB	—	10	V	102	M	H4	#
	Series code		Rated voltage symbol		Rated capacitance symbol	Capacitance tolerance symbol	Casing symbol	
Former item	RJB	—	10	V	102	M	H4	
	Series code		Rated voltage symbol		Rated capacitance symbol	Capacitance tolerance symbol	Casing symbol	

- The standard ratings are described on the next page.

### Standard Ratings

Rated voltage(V)			6.3					10				
Case ø DxL(mm)	Casing symbol	Item	Rated capacitance	ESR	Impedance Ω/100kHz		Rated ripple current	Rated capacitance	ESR	Impedance Ω/100kHz		Rated ripple current
			μF	Ω	20°C	-10°C	mArms	μF	Ω	20°C	-10°C	mArms
5x11.5	E3	—	—	—	—	—	—	100	3.15	0.65	1.30	181
6.3x11.5	F3	330	1.11	0.32	0.64	290	220	1.43	0.32	0.64	290	290
8x12	G3	470	0.78	0.17	0.34	555	330	0.96	0.17	0.34	555	555
8x12	G3	680	0.54	0.17	0.34	555	470	0.67	0.17	0.34	555	555
10x12.5	H3	1000	0.36	0.12	0.24	760	680	0.46	0.12	0.24	760	760
10x16	H4	—	—	—	—	—	1000	0.32	0.080	0.16	1050	1050
10x25	H6	2200	0.18	0.052	0.104	1440	—	—	—	—	—	—
12.5x20	I 5	3300	0.13	0.042	0.084	1690	2200	0.16	0.042	0.084	1690	1690
12.5x25	I 6	—	—	—	—	—	3300	0.12	0.034	0.068	1950	1950
12.5x30	I 7	4700	0.10	0.030	0.060	2310	—	—	—	—	—	—
16x25	J 6	6800	0.08	0.028	0.056	2560	4700	0.09	0.028	0.056	2560	2560
16x31.5	J 7	10000	0.06	0.025	0.050	3010	6800	0.07	0.025	0.050	3010	3010

Rated voltage(V)			16					25				
Case ø DxL(mm)	Casing symbol	Item	Rated capacitance	ESR	Impedance Ω/100kHz		Rated ripple current	Rated capacitance	ESR	Impedance Ω/100kHz		Rated ripple current
			μF	Ω	20°C	-10°C	mArms	μF	Ω	20°C	-10°C	mArms
5x11.5	E3	—	—	—	—	—	—	47	4.94	0.65	1.30	181
6.3x11.5	F3	—	—	—	—	—	—	100	2.32	0.32	0.64	290
8x12	G3	330	0.81	0.17	0.34	555	220	1.06	0.17	0.34	555	555
10x12.5	H3	470	0.57	0.12	0.24	760	330	0.70	0.12	0.24	760	760
10x16	H4	680	0.39	0.080	0.16	1050	470	0.50	0.080	0.16	1050	1050
10x20	H5	1000	0.27	0.062	0.124	1220	680	0.34	0.062	0.124	1220	1220
12.5x20	I 5	—	—	—	—	—	1000	0.23	0.042	0.084	1690	1690
12.5x25	I 6	2200	0.14	0.034	0.068	1950	—	—	—	—	—	—
16x25	J 6	3300	0.10	0.028	0.056	2560	2200	0.12	0.028	0.056	2560	2560
16x31.5	J 7	4700	0.08	0.025	0.050	3010	3300	0.09	0.025	0.050	3010	3010

Rated voltage(V)			35					50				
Case ø DxL(mm)	Casing symbol	Item	Rated capacitance	ESR	Impedance Ω/100kHz		Rated ripple current	Rated capacitance	ESR	Impedance Ω/100kHz		Rated ripple current
			μF	Ω	20°C	-10°C	mArms	μF	Ω	20°C	-10°C	mArms
5x11.5	E3	33	6.03	0.65	1.30	181	22	7.54	0.95	1.9	170	170
6.3x11.5	F3	47	4.23	0.32	0.64	290	33	5.03	0.46	0.92	260	260
6.3x11.5	F3	—	—	—	—	—	47	3.53	0.46	0.92	260	260
8x12	G3	100	1.99	0.17	0.34	555	100	1.66	0.21	0.42	485	485
10x12.5	H3	220	0.91	0.12	0.24	760	150	1.11	0.19	0.38	615	615
10x16	H4	330	0.60	0.080	0.16	1050	220	0.75	0.16	0.32	850	850
10x20	H5	470	0.42	0.062	0.124	1220	330	0.50	0.085	0.17	1050	1050
12.5x20	I 5	680	0.29	0.042	0.084	1690	470	0.35	0.060	0.12	1500	1500
12.5x25	I 6	1000	0.20	0.034	0.068	1950	680	0.24	0.045	0.090	1832	1832
16x25	J 6	—	—	—	—	—	1000	0.17	0.038	0.076	2240	2240
16x31.5	J 7	2200	0.11	0.025	0.050	3010	—	—	—	—	—	—

Rated voltage(V)			63					100				
Case ø DxL(mm)	Casing symbol	Item	Rated capacitance	ESR	Impedance Ω/100kHz		Rated ripple current	Rated capacitance	ESR	Impedance Ω/100kHz		Rated ripple current
			μF	Ω	20°C	-10°C	mArms	μF	Ω	20°C	-10°C	mArms
5x11.5	E3	4.7	31.8	1.2	3.6	120	3.3	40.2	1.9	7.6	57	57
5x11.5	E3	10	14.9	1.2	3.6	120	4.7	28.2	1.9	7.6	57	57
6.3x11.5	F3	22	6.79	0.55	1.7	148	10	13.3	1.1	4.4	78	78
6.3x11.5	F3	33	4.52	0.55	1.7	148	—	—	—	—	—	—
8x12	G3	47	3.18	0.32	0.96	360	22	6.03	0.53	2.1	275	275
10x12.5	H3	100	1.49	0.23	0.69	448	33	4.02	0.47	1.9	319	319
10x16	H4	—	—	—	—	—	47	2.82	0.32	1.3	424	424
10x20	H5	220	0.68	0.12	0.36	676	—	—	—	—	—	—
12.5x20	I 5	330	0.45	0.075	0.23	979	100	1.33	0.13	0.52	805	805
12.5x25	I 6	470	0.32	0.065	0.20	1180	—	—	—	—	—	—
16x25	J 6	—	—	—	—	—	220	0.60	0.081	0.32	1290	1290
16x25	J 6	—	—	—	—	—	330	0.40	0.081	0.32	1290	1290
16x31.5	J 7	1000	0.15	0.042	0.13	1890	470	0.28	0.059	0.23	1630	1630

(Note) ESR : 20°C, 120Hz ; Rated ripple current : 105°C, 100kHz

## X-ON Electronics

Largest Supplier of Electrical and Electronic Components

*Click to view similar products for [Aluminium Electrolytic Capacitors - Radial Leaded](#) category:*

*Click to view products by [Elna](#) manufacturer:*

Other Similar products are found below :

[LXY50VB4.7M-5X11](#) [B41041A2687M8](#) [B41041A7226M8](#) [B41044A7157M6](#) [EPA-201ELL151MM25S](#) [NCD681K10KVY5PF](#) [KM4700/16](#)  
[KME50VB100M-8X11.5](#) [SG220M1CSA-0407](#) [ES5107M016AE1DA](#) [ESRL25V330](#) [ESX472M16B](#) [SZ010M1500A5S-1015](#) [227RZS050M](#)  
[476CKH100MSA](#) [KME25VB100M-6.3X11](#) [XRL50V22](#) [052687X](#) [107CKR010M](#) [EKMA500ELL4R7ME07D](#) [NRE-S560M16V6.3X7TBSTF](#)  
[RGA221M1CTA-0611G](#) [ERZA630VHN182UP54N](#) [UPL1A331MPH](#) [MAL214658821E3](#) [SK107M025AE3EAKPLP](#) [B43827A1106M8](#)  
[B41022A5686M6](#) [EKMA160EC3101MF07D](#) [ESMG160ETD221MF11D](#) [EKZH160ETD152MJ20S](#) [EKMA350ELL100ME07D](#)  
[ESMG160ETD101ME11D](#) [SK107M025AE3KAKPLP](#) [EKMG350ETD471MJ16S](#) [35YXA330MEFC10X12.5](#) [RGA221M2ABK-1320G](#)  
[ERR1HM1R0D11OT](#) [ERR1CM222W20OT](#) [TM1081EMF202RB](#) [RXQ271M2EBK-1836](#) [B41896C5278M](#) [B41851A8107M000](#)  
[UHW2A471MHD6](#) [EKMA160ETD470MF07D](#) [510D476M035CC3DE3](#) [SK228M025AH5AAKPLP](#) [LKMK2502W101MF](#)  
[450MXH330MEFCSN25X45](#) [450MXK330MA2RFC22X50](#)