

Miniature Standard Capacitors for Audio

GREEN CAP For Audio

TONEREX

- Adopting the newly developed formation method and composite electrolytic paper for audio application has reduced distortion, achieving high-quality sound.
- All lead wires are oxygen-free copper wires to reduce distortion.

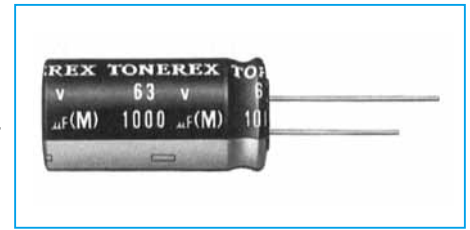

Marking color : Gold print on a black sleeve

Specifications

Item	Performance									
Category temperature range (°C)	-40 to +85									
Tolerance at rated capacitance (%)	±20 (20°C,120Hz)									
Leakage current (μA)	Less than 0.01CV or 4 whichever is larger (after 5 minutes) C : Rated capacitance (μF) ; V : Rated voltage (V) (20°C)									
Tangent of loss angle (tanδ)	Rated voltage (V)	6.3	10	16	25	35	50	63	100	
	tanδ (max.)	0.24	0.20	0.16	0.14	0.12	0.10	0.09	0.08	
0.02 is added to every 1000μF increase over 1000μF (20°C,120Hz)										
Endurance (85°C) (Applied ripple current)	Test time	1000 hours								
	Leakage current	The initial specified value or less								
	Percentage of capacitance change	Within ±20% of initial value								
	Tangent of the loss angle	150% or less of the initial specified value								
Shelf life (85°C)	Test time : 1000 hours. Other have same as endurance. Voltage application treatment : According to JIS C5101 -1									
Applicable standards	JIS C5101-1, -4 1998 (IEC 60384-1 1992, -4 1985)									

Outline Drawing

Unit : mm

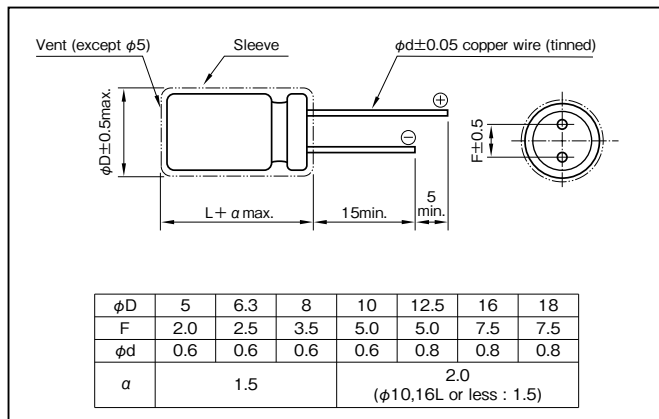

Coefficient of Frequency for Rated Ripple Current

Rated voltage (V)	Frequency (Hz) CV (μF×VV)	50·60	120	1k	10k	100k
		6.3 to 16	All CV value	0.8	1	1.1
25 to 35	≤1000	0.8	1	1.5	1.7	1.7
	1000<	0.8	1	1.2	1.3	1.3
50 to 100	≤1000	0.8	1	1.6	1.9	1.9
	1000<	0.8	1	1.2	1.3	1.3

Part numbering system (example : 25V100μF)

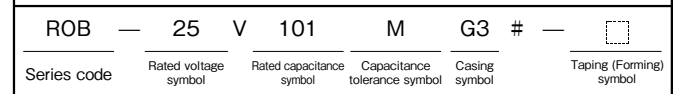

Case symbol

Case Symbol	Casing Symbol	Case φD×L (mm)	Casing Symbol	Case φD×L (mm)	Casing Symbol	Case φD×L (mm)	Casing Symbol
5×11	E3	10×12.5	H3	12.5×20	I5	16×31.5	J7
6.3×11	F3	10×16	H4	12.5×25	I6	16×35.5	J8
8×11.5	G3	10×20	H5	16×25	J6	18×35.5	K8
						18×40	K9

Standard Ratings

Rated capacitance (μF)	Item	6.3		10		16		25		35		50		63		100	
		Case φD×L (mm)	Rated ripple current (mArms)	Case φD×L (mm)	Rated ripple current (mArms)	Case φD×L (mm)	Rated ripple current (mArms)	Case φD×L (mm)	Rated ripple current (mArms)	Case φD×L (mm)	Rated ripple current (mArms)	Case φD×L (mm)	Rated ripple current (mArms)	Case φD×L (mm)	Rated ripple current (mArms)	Case φD×L (mm)	Rated ripple current (mArms)
1		—	—	—	—	—	—	—	—	—	—	5×11	10	—	—	5×11	15
2.2		—	—	—	—	—	—	—	—	—	—	5×11	20	—	—	5×11	25
3.3		—	—	—	—	—	—	—	—	—	—	5×11	25	—	—	5×11	30
4.7		—	—	—	—	—	—	5×11	25	—	—	5×11	35	5×11	35	6.3×11	40
10		—	—	—	—	5×11	35	5×11	40	5×11	45	5×11	50	6.3×11	60	8×11.5	70
22		—	—	5×11	50	5×11	60	5×11	60	6.3×11	75	6.3×11	80	8×11.5	100	10×12.5	120
33		5×11	55	5×11	65	5×11	70	6.3×11	80	6.3×11	90	8×11.5	110	8×11.5	115	10×16	160
47		5×11	65	5×11	75	6.3×11	95	6.3×11	100	8×11.5	120	8×11.5	130	10×12.5	165	10×20	210
100		6.3×11	110	6.3×11	120	8×11.5	150	8×11.5	165	10×12.5	210	10×16	250	10×20	285	12.5×20	340
220		8×11.5	185	8×11.5	200	10×12.5	265	10×16	310	10×20	365	12.5×20	440	12.5×20	470	16×25	620
330		10×12.5	265	10×12.5	290	10×16	350	10×20	410	12.5×20	500	12.5×20	540	12.5×25	620	16×31.5	820
470		10×12.5	315	10×16	380	10×20	460	12.5×20	550	12.5×25	640	16×25	800	16×25	840	18×35.5	1000
1000		10×20	550	12.5×20	670	12.5×25	810	16×25	1000	16×25	1050	16×31.5	1200	18×35.5	1500	—	—
2200		12.5×25	980	16×25	1200	16×25	1350	16×35.5	1650	18×35.5	1900	—	—	—	—	—	—
3300		16×25	1300	16×31.5	1600	16×35.5	1800	18×40	2100	—	—	—	—	—	—	—	—
4700		16×31.5	1700	16×35.5	1900	18×35.5	2400	—	—	—	—	—	—	—	—	—	—
6800		16×35.5	2100	18×40	2600	—	—	—	—	—	—	—	—	—	—	—	—
10000		18×40	2800	—	—	—	—	—	—	—	—	—	—	—	—	—	—

(Note) Rated ripple current : 85°C, 120Hz

NOTE : Design, Specifications are subject to change without notice. It is recommended that you shall obtain technical specifications from ELNA to ensure that the component is suitable for your use.

## X-ON Electronics

Largest Supplier of Electrical and Electronic Components

*Click to view similar products for [elna](#) manufacturer:*

Other Similar products are found below :

[RFS-50V2R2MF35](#) [DBJ-5R5D105T](#) [RVJ-50V101MH10U-R](#) [RFS-63V471MK85](#) [RFS-50V471MJ85](#) [PVM-10V470ME60E-R2](#) [DZN-2R5D506T](#) [RFS-25V220MF3#5](#) [RFS-63V101MI6#5](#) [DBN-5R5D104T](#) [PVM-10V221MG70E-R2](#) [RFS-10V332MK9#5](#) [RFS-100V470MI6#5](#) [DZ-2R5D506T](#) [DXJ-5R5H334U](#) [459546X](#) [DZH-2R5D307S57T](#) [LAO-63V103MS47PX#B](#) [RJH-25V222MI9#](#) [RFS-35V471MJ75](#) [LA5-100V103MS5BP#B](#) [LAO-80V103MS57PXT#B](#) [DX-5R5H104U](#) [RFS-35V331MJ65](#) [ROB-10V682MK9](#) [ROB-10V682MK9#](#) [DX-5R5V104U](#) [RFS-16V102MJ75](#) [DVL-5R5D473T-R5](#) [RFS-16V102MJ7#5](#) [RFS-10V332MK95](#) [RFS-50V221MJ65](#) [DC-2R5D204T614](#) [RE3-35V222MJ6#](#) [RFS-25V220ME3#5](#) [RFS-50V102MK9#5](#) [ROB-100V470MH5](#) [ROB-100V470MH5#](#) [DBN-5R5D105T](#) [RFS-35V221MI65](#) [DVN-5R5D224T-R5](#) [DZ-2R5D106T](#) [RFS-6V470MF3#5](#) [DHL-5R5D224GT](#) [DCK-3R3E224U-E](#) [RFS-100V101MJ65](#) [ROB-100V101MI5](#) [DSK-3R3H224U-HL](#) [DBN-5R5D473T](#) [DB-5R5D474T](#)