

## iMX RT1176 uCOM Board Feature Highlights

- NXP i.MX RT1176 Arm® Cortex®-M7, up to 1000 MHz, and Cortex-M4, up to 400 MHz. 6468 CoreMarks
- 16 MByte QSPI Flash
- 32 MByte SDRAM, 32-bit databus
- MIPI-DSI graphical output and MIPI-CSI camera input
- Low-power consumption - very power efficient
- FreeRTOS BSP
- **Multiple Wi-Fi solutions available**  
Optional Murata 1ZM Wi-Fi/BT module supporting 802.11 a/b/g/n/ac and BT/BLE 5.1
- 42 x 45 mm small form factor
- Long term availability

## Introduction

The **iMX RT1176 uCOM Board** provides a quick and easy solution for implementing a high-performance Arm Cortex-M7/M4 based design. The i.MX RT1176 is the highest performing Cortex-M solution with Real Time Operation and an applications processor level of functionality, delivering 6468 CoreMark/2974 DMIPS @ 1000/400 MHz. It has very low dynamic power consumption, enabled by integrated DC-DC converter and efficient power gating.

The i.MX RT1176 has a **2D vector graphics core** and has display interfaces, supporting up to 1920x1080px resolution at 30Hz. It also has high security enabled by AES-128/256, Elliptical Curve Cryptography, RSA-4096 encryption algorithms, hashing acceleration for SHA-256/512 and On-the-fly QSPI Flash Decryption.

Rapid and easy development with support from major microcontroller tool chains. The BSP contains a FreeRTOS port. Typical applications are graphical interface solutions for home, building and industrial control, communication solutions and connected real-time systems.

## Specification

Processor	Cores / MCU	ARM Cortex-M7/Cortex-M4 / NXP i.MX RT1176
	Frequency	1000/800 MHz for M7 and 400/240 MHz for M4 (commercial/industrial temp range)
Memory	On-chip SRAM	2 MByte (768 KByte FlexRAM, can be used as Tightly Coupled Memory and 1.25 MByte OCRAM) and 4KByte Secure always-on RAM
	SDRAM	32 MByte, 32-bit databus
	FLASH	16 MByte QSPI
Graphics output	MIPI-DSI	2 lanes with resolution up to 1920x1080px at 30 Hz (1080p30)
	Parallel RGB	24-bit with resolution up to 1280x800px at 60Hz. <b>Note:</b> Not available with standard mounting option!
	2D Graphics Engine	2D GPU with OpenVG 1.1 support and 2D accelerator (PXP)
Graphics input	CMOS sensor interface (camera)	1x MIPI-CSI2, 2 lanes, up to 1.5 Gbps Parallel input bus also available, up to 16 bits available
	Wi-Fi/BT	Optional Murata LBEE5QD1ZM (1ZM) Wi-Fi/BT module, 802.11 a/b/g/n/ac and BT/BLE 5.1, SDIO
Ethernet		1x Gigabit Ethernet interface based on Atheros AR8031 Ethernet PHY Second 10/100 Mbps Ethernet interface, requires external Ethernet-PHY on carrier board
I/O (all functions are not available at the same time)	USB	2x FS USB2.0 OTG
	Memory card/SDIO	2x SD3.0, One used for optional on-board Wi-Fi/BT module
	UART, SPI, I2C, Audio	12x UART, 6x SPI, 6x I2C, 4x SAI, 1x S/PDIF
	CAN	3x CAN bus 2.0B
	GPIO, FlexIO, Timers	Large number of GPIOs and keypad pins, 2x FlexIO blocks, 6x GPT, 2x PIT, 4x QTimer, 4x PWM
	ADC, DAC, Analogue	16ch ADC 12-bit resolution, 1x 12-bit DAC, 4x comparators,
Other	Watchdog	On-board watchdog functionality
	RTC	On-chip iMX RT1176
	Power Management	On-chip iMX RT1176 power management

	Accelerators	Encryption engine co-processor, True random number generator
	E2PROM	64kbit I2C-E2PROM and 1kbit I2C-E2PROM with EUI-48 number for unique Ethernet-MAC address
Power	Supply voltage	4 to 5.0V input. On-board 3.3V (about 1A) and 1.8V (about 0.5A) supplies for external use on carrier board
	Power consumption	See datasheet for details. Typically much less than 1 Watt.
Environment	Operating Temp.	0 - 70° or -40 - 85° Celsius
	Operating Humidity	5 - 90% relative humidity, non-condensing
Mechanical	Dimensions (WxHxD)	42 x 45 x 5 mm, EAuCOM form factor
Connectors		2x DF40C-100 and 2x DF40C-40 connectors, 0.4 mm pitch. 280 pins in total
		Optional u.fl. antenna connector if Wi-Fi/BT module mounted

Note that all interfaces may not be available simultaneously due to I/O multiplexing limitations.

## Block Diagram

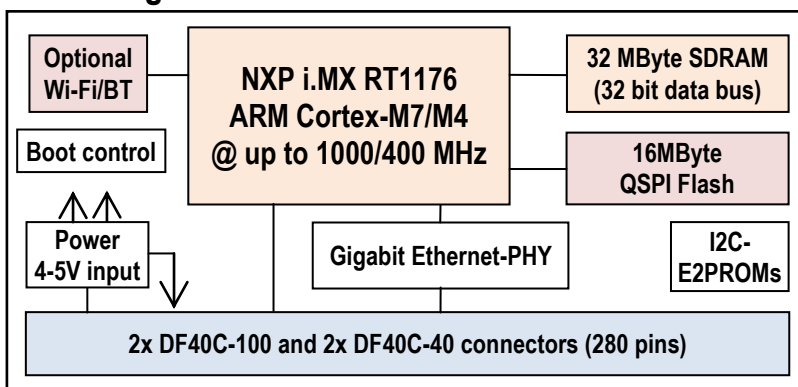

## Ordering Information

Part No. <sup>[1]</sup>	CPU	Core Frequency	SDRAM	Wi-Fi/BT	QSPI	Operating Temp.
<b>EAC00377</b>	MIMXRT1176DVMAA	1000/400 MHz max	32 MByte	No	16 MByte	0 - 70 °C
<b>EAC00381</b>	MIMXRT1176CVM8A	800/240 MHz max	32 MByte	No	16 MByte	-40 - 85 °C

[1] Standard configurations listed. Wi-Fi/BT and other memory configurations on request. All configurations may not be stocked.

## Support Highlights

Embedded Artists is a reliable and competent partner - we help you become successful!

- Professional and responsive support
- Carrier boards with reference implementations
- Custom Carrier board design
- Customization
  - Different pinning, supply voltage, memory sizes, etc
  - Single Board Computer (SBC) solutions
- Display solutions
- Mechanical solutions
- Schematic review of customer carrier board designs
- Driver and application development

## Development Kit

The iMX RT1176 uCOM Board are supported by the **iMX RT1176 uCOM Developer's Kit** that provides a quick path to get started with development and integration work. The kits provides reference implementations of key interfaces. Ordering part No. **EAK00380**

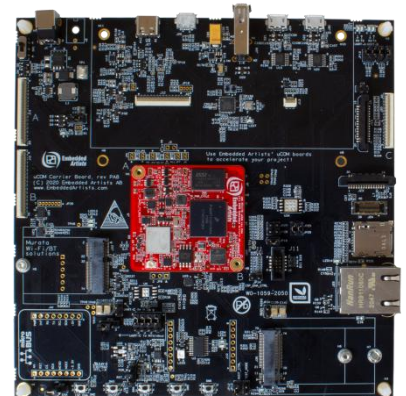

**Disclaimer:** Embedded Artists reserves the right to make changes to information published in this document, including without limitation specifications and product descriptions, at any time and without notice.

## X-ON Electronics

Largest Supplier of Electrical and Electronic Components

*Click to view similar products for [Development Boards & Kits - ARM category](#):*

*Click to view products by [Embedded Artists manufacturer](#):*

Other Similar products are found below :

[CY4541](#) [OM13090UL](#) [YR0K77210B000BE](#) [B-U585I-IOT02A](#) [NUCLEO-WL55JC1](#) [ZDSD-Pinboard](#) [LKS32MC034DOF6Q8-k](#)  
[LKS32MC077MBS8-K](#) [LKS32MC038Y6P8B-K](#) [LKS32MC071DOC8T8-K](#) [LKS32MC074DOF8Q8-K](#) [LKS32MC071CBT8-K](#)  
[LKS32MC038Y6P8-k](#) [Ai-WB2-32S-Kit](#) [GD32E103T-START](#) [GD32L233K-START](#) [XDS601](#) [RP2040-Tiny](#) [M6G2C-256LI](#) [YT37](#)  
[LKS32MC033H6P8B-K](#) [VC-02-Kit\\_EN](#) [Ra-08H-Kit](#) [Hi-12FL-Kit](#) [PB-03M-Kit](#) [Ai-WB2-13-Kit](#) [PB-03F-Kit](#) [Ra-08-Kit](#) [Hi-07SL-Kit](#) [Hi-](#)  
[07S-Kit](#) [Ai-WB2-12F-Kit](#) [PB-03-Kit](#) [Hi-12F-Kit](#) [AT-START-F407](#) [E104-BT40-TB](#) [APM32F072VBT6](#) [APM32F091VC MINI](#)  
[APM32F407IG-MINIBOARD](#) [APM32F051R8 MINI](#) [GD32FPRT-START](#) [GD32407H-START-1](#) [GD32E503V-EVAL](#) [GD32E507R-START](#)  
[GD32403V-START-1](#) [EPC1EVK-ECGPPG\(FS\)](#) [NS4EVKA-LC](#) [ENS1EVKD](#) [.ENS1EVKB](#) [ENS1EVKE](#) [HLK-7621-ALL-SUIT](#)