

EMOSAFE EN-100

Product Datasheet

Network Isolators for PCB assembly

December 2015



1 FEATURES AND ADVANTAGES

- Suitable for PCB assembly: pluggable or solderable
- Ultra-compact
- Conforms to IEC 60601-1 (3rd Edition)
- 10/100/1000 Mbit/s Ethernet
- Outstanding Ethernet performance in accordance with ISO 11801 Class D
- UL Recognized Component
- Conforms to RoHS
- 4.6 kV AC dielectric strength
- 8.5 kV DC dielectric strength
- Transient voltage suppression on all signal lines
- Suitable for devices with supply voltages of up to 400 V AC
- 100% quality control testing

2 GENERAL DESCRIPTION

EMOSAFE EN-100 Network Isolators disconnect every electrically conducting connection (specifically the data and shield conductors) between devices connected together via a copper-based Ethernet network. The Network Isolators prevent current flow resulting from differences in electrical potentials, and also protect connected devices and their users from stray external voltages and power surges which may be directly or inductively coupled onto the network lines by causes such as installation errors, lightning, switching operations, and electrostatic discharge.

EMOSAFE EN-100 Network Isolators are intended for integration into printed circuit boards (PCBs) of electronic devices requiring advanced protection. Models are available with socket strips for plug-in assembly, and there are models that can be permanently soldered in place. Their extremely compact design allows them to be utilised in situations where there is limited physical space. A summary of the available variants can be found in section [4 SUMMARY OF VARIANTS](#).

All EN-100 Network Isolators offer a particularly effective level of device protection. Voltage spikes on individual signal conductors are eliminated by means of a supplementary transient voltage suppression (TVS) diode circuit. These transient voltages cannot be repressed by conventional network isolators. However, even these are eliminated by the EN-100.

The entire EN-100 series meet the requirements of IEC 60601-1 (3rd Edition) and IEC 60601-1-2, and as such are suitable for providing medical electrical (ME) devices the required galvanic isolation for their Ethernet interfaces.

EMOSAFE Network Isolators transmit high-frequency signals through the principle of electromagnetic induction. Because of this, they do not require their own power supplies. There are no software drivers to be installed.

Low-frequency signal components are strongly attenuated, so that connected devices may, for example, be protected against ground loops.

3 APPLICATIONS

3.1 PATIENT PROTECTION

Electrical separation of Ethernet interfaces of medical electrical (ME) devices and systems, where patients must be protected from dangerous leakage currents, in conformity with applicable standards.

3.2 EQUIPMENT PROTECTION

Applications, in which valuable devices or those requiring special protection need to be protected against ripple, mains hum, and surge voltages from the network periphery.

3.3 MEASUREMENT TECHNOLOGY

Electrical measuring and monitoring equipment, which needs to be protected against external voltages and interference voltages arising from the Ethernet periphery.







3.4 AUDIO

Audio applications, in which the transmission of low frequency alternating current voltages (mains hum) over the network connection is to be reduced to an imperceptible level.

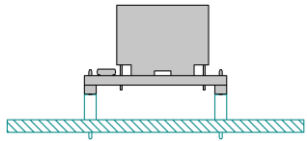
4 SUMMARY OF VARIANTS

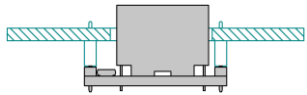
EN-100

Network Isolators
for PCB assembly

	Name Article number	Special features	AC dielectric strength in kV	TVS diodes	10/100/1000 Mbit/s	Typical Return Loss in dB @ 100 MHz	Typical Insertion Loss in dB @ 100 MHz	Configuration
<p>Pluggable</p> 	<p>EN-100T A10049</p>	<p>Extra-short length between inputs and outputs.</p> <p>Downwards-facing pins.</p> <p>In-circuit pluggable and solderable.</p>	4.6	✓	✓	17	0.8	
<p>Pluggable</p> 	<p>EN-100L A10050</p>	<p>Extra-short length between inputs and outputs.</p> <p>Upwards-facing pins.</p> <p>In-circuit pluggable and solderable.</p>	4.6	✓	✓	17	0.8	
<p>Solderable</p> 	<p>EN-100S A10048</p>	<p>Extra-short length between inputs and outputs.</p> <p>Edge soldering receptacles for manual assembly.</p> <p>Solderable.</p>	4.6	✓	✓	17	0.8	
<p>Solderable</p> 	<p>EN-100C A10051</p>	<p>Milling of PCB is not required.</p> <p>Edge soldering receptacles for manual assembly.</p> <p>Solderable.</p>	4.6	✓	✓	17	0.8	

5 DRAWINGS

All dimensions in millimetres.

5.1 EN-100T

5.1.1 EN-100T MODULE DIMENSIONS

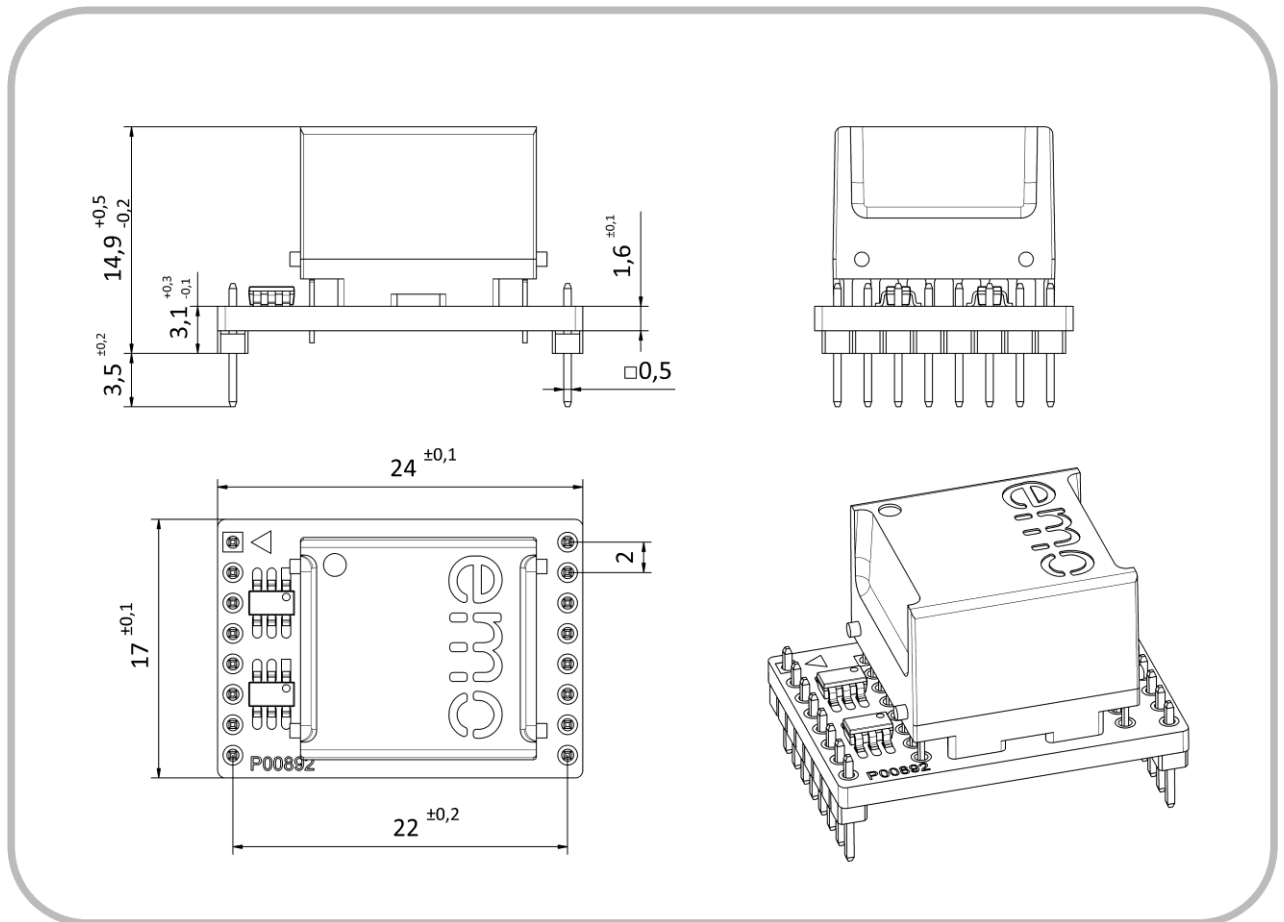

Figure 1. Physical dimensions of the EN-100T module.

5.1.2 EN-100T ASSEMBLY DIMENSIONS

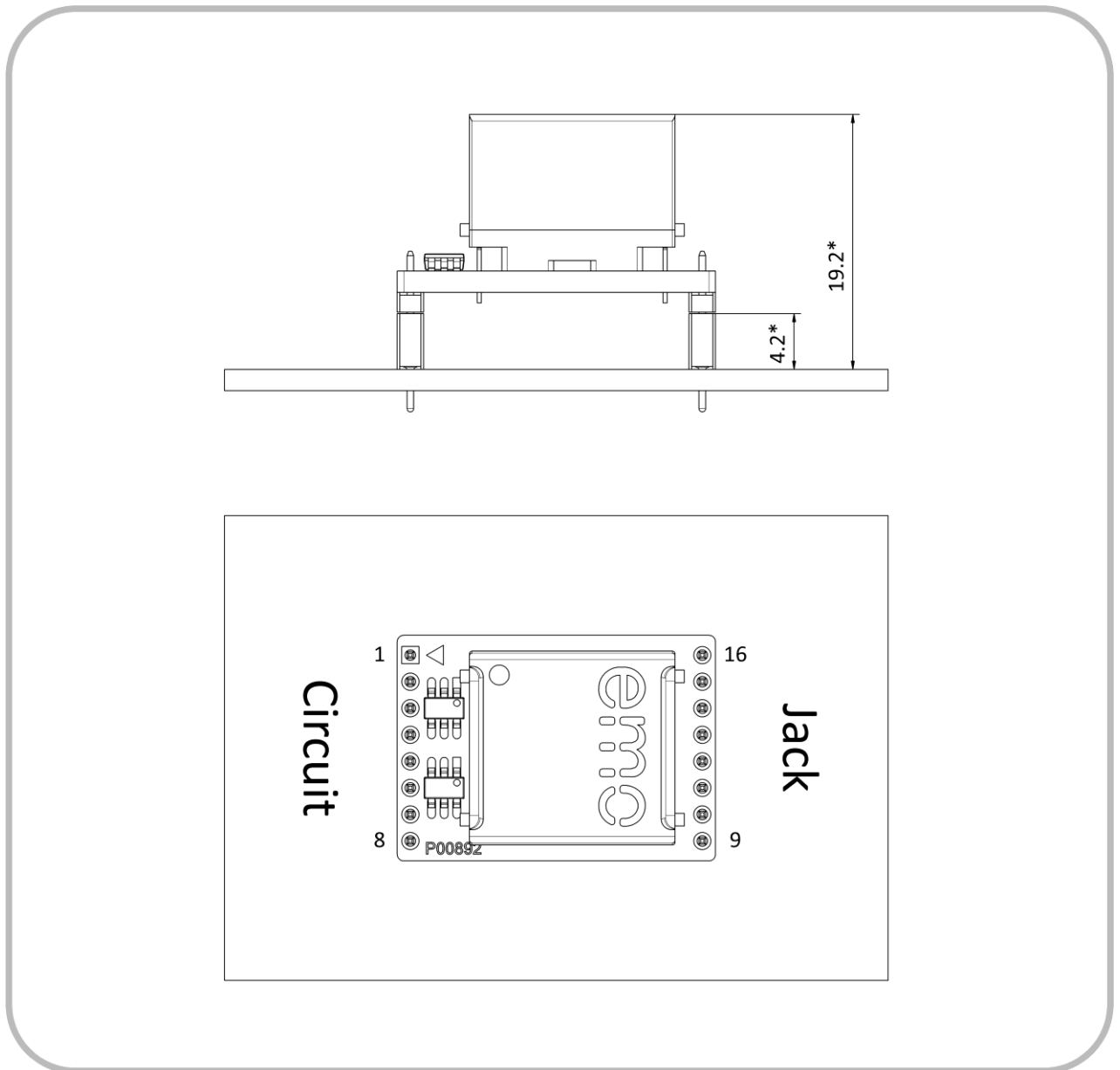

Figure 2. Physical dimensions of an EN-100T assembled onto a PCB. The labels **Jack** and **Circuit** indicate the intended locations of the RJ45 Ethernet Jack and the product circuitry, respectively.

* The pin connectors may be directly soldered onto the PCB, or plugged into a pre-mounted socket strip. Figure 2 illustrates a socket strip with a height of 4.2 mm. The total assembly height is reduced by this amount when a socket strip is not used.

5.1.3 EN-100T PCB LAYOUT

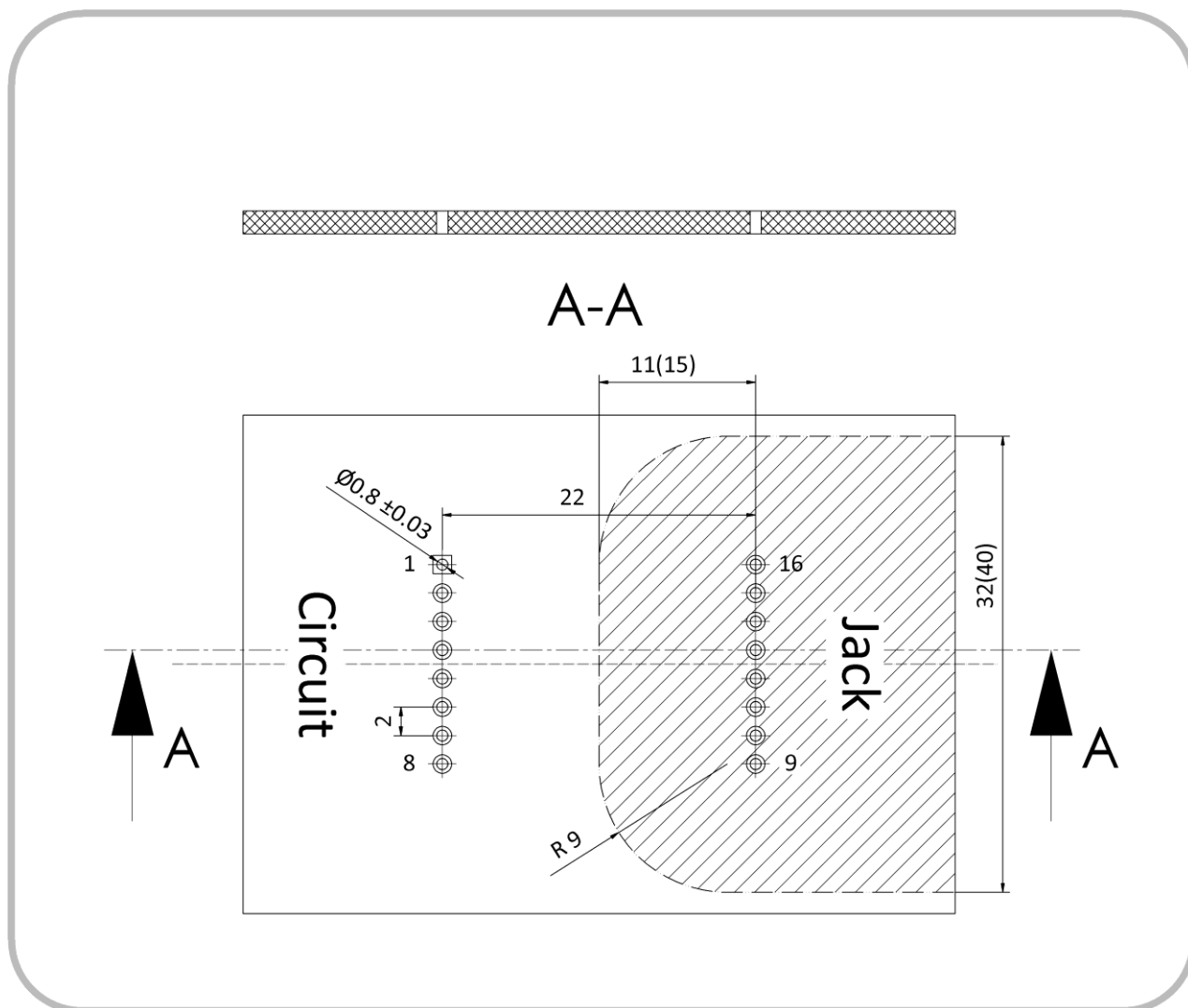

Figure 3. Suggested PCB layout for the EN-100T.

When fitting PCB socket strips, ensure that they are suitable for the EN-100T, and that they match the PCB holes.
Dimensions in parentheses indicate the clearances required for environments with voltages up to 400 V AC.

PCB traces and other conducting surfaces must not be present in the hatched area, except for those connecting the EN-100T to the Ethernet Jack. This is required in order to maintain the creepage and clearance distances.

The dimensions of the hatched area are based upon requirements for realising two means of patient protection (MOPP) for medical electrical (ME) devices. For such ME applications, those with operating voltages of up to 250 V AC require the dimensions indicated in Figure 3 to be met or exceeded, and those with operating voltages of up to 400 V AC require the dimensions indicated in parentheses in Figure 3 to be met or exceeded.

However, the actual requirements for the clearance and creepage distances vary with device and application, and must be determined and verified. The assembly of the Network Isolator in a manner that satisfies requirements and relevant standards is the responsibility of the device manufacturer.

5.2 EN-100L

5.2.1 EN-100L MODULE DIMENSIONS

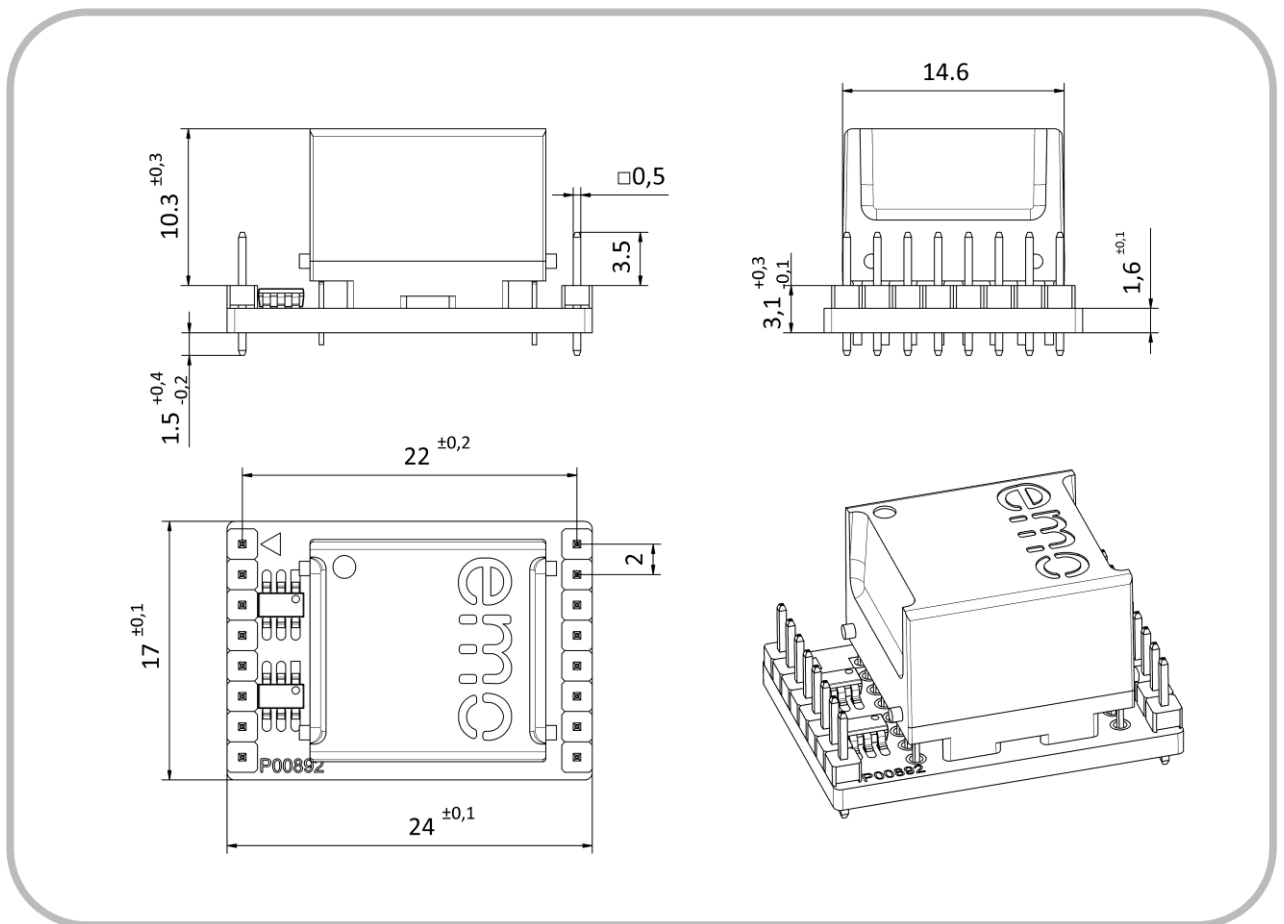

Figure 4. Physical dimensions of the EN-100L module.

5.2.2 EN-100L ASSEMBLY DIMENSIONS

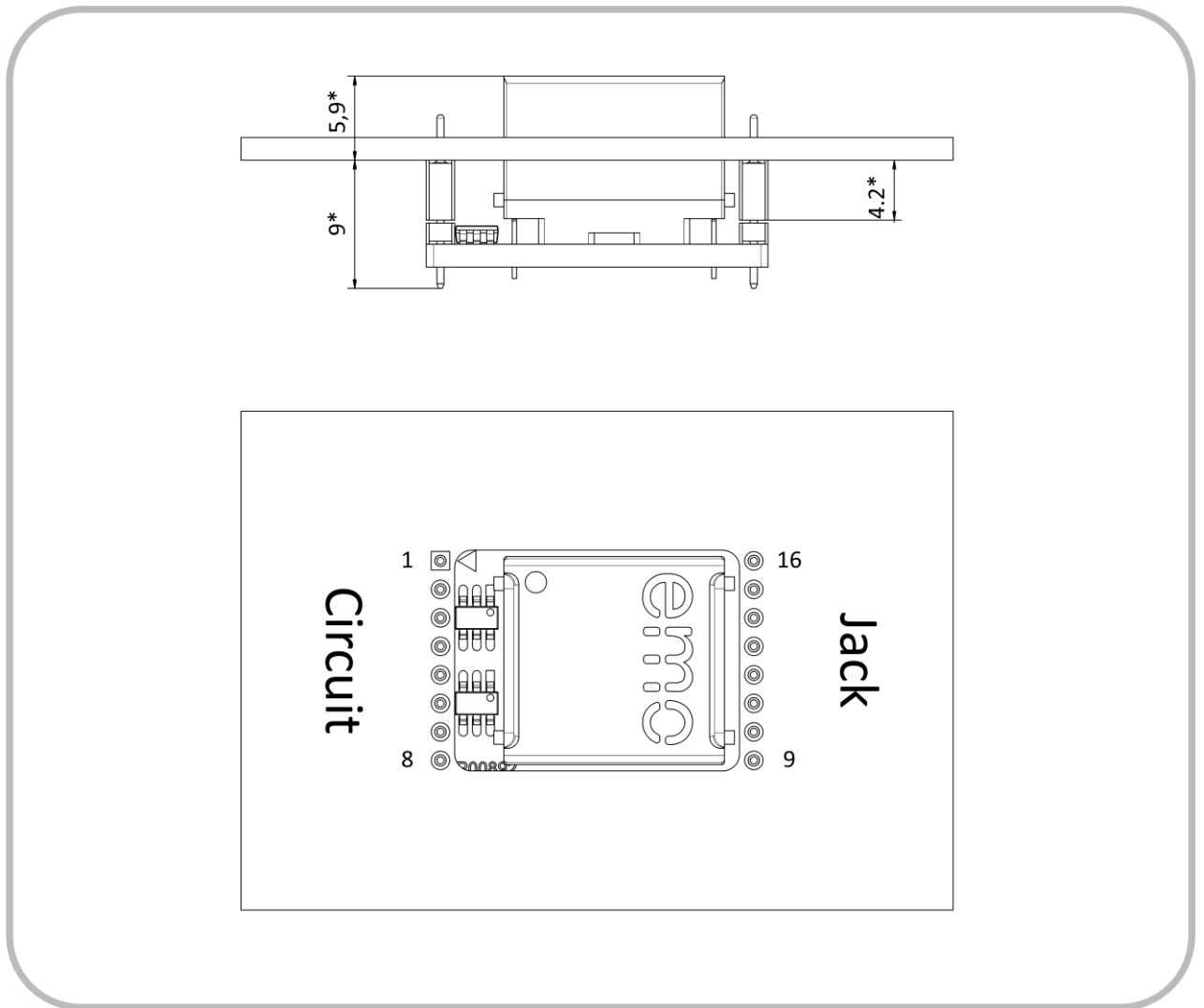

Figure 5. Physical dimensions of an EN-100L assembled onto a PCB. The labels **Jack** and **Circuit** indicate the intended locations of the RJ45 Ethernet Jack and the product circuitry, respectively.

* The pin connectors may be directly soldered onto the PCB, or plugged into a pre-mounted socket strip. Figure 5 illustrates a socket strip with a height of 4.2 mm. The final assembly position is changed by this amount when a socket strip is not used.

5.2.3 EN-100L PCB LAYOUT

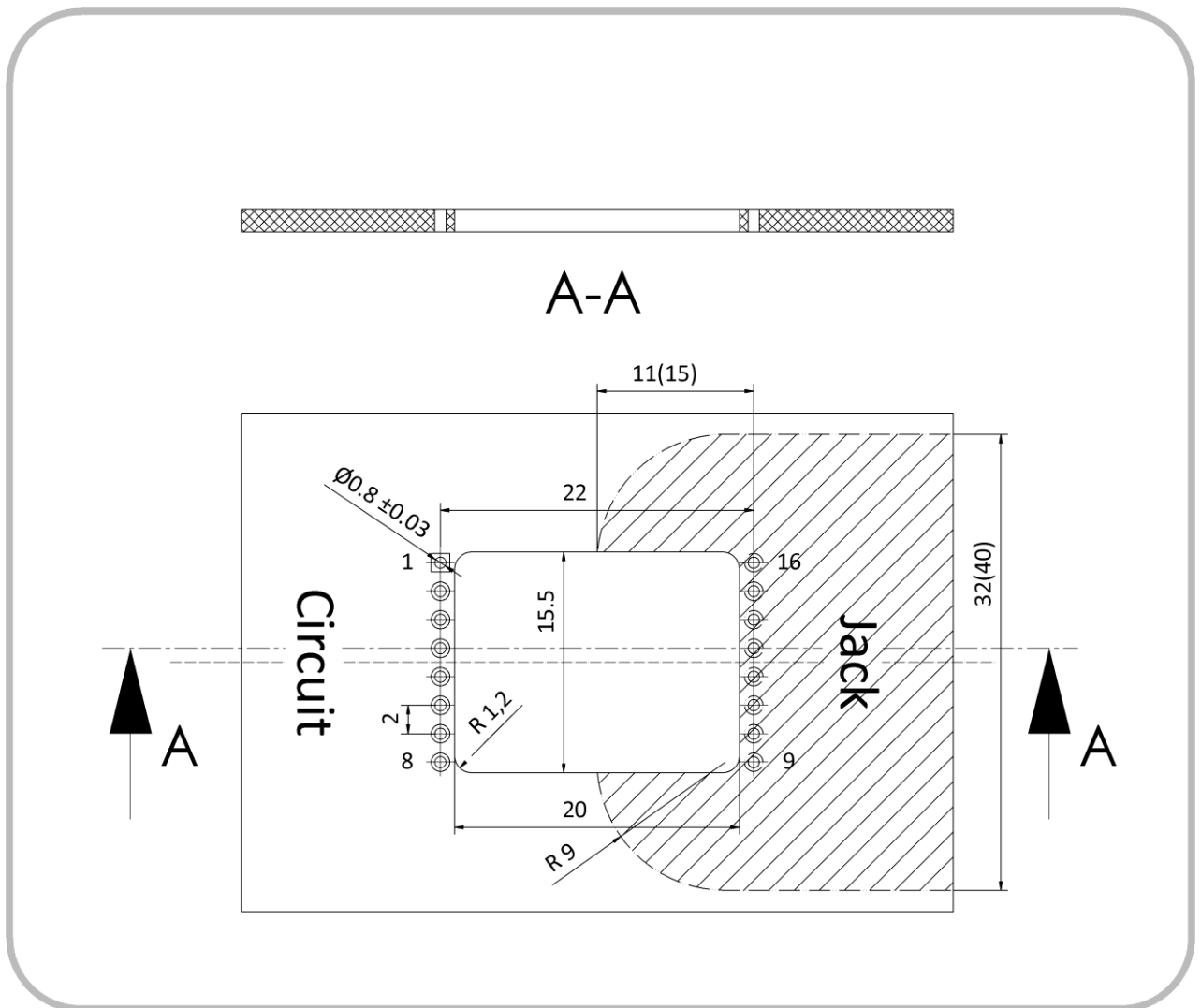

Figure 6. Suggested PCB layout for the EN-100L.
 Pay careful attention to the required PCB cut-out area, as detailed.
 When fitting PCB socket strips, ensure that they are suitable for the EN-100L, and that they match the PCB holes.
 Dimensions in parentheses indicate the clearances required for environments with voltages up to 400 V AC.

PCB traces and other conducting surfaces must not be present in the hatched area, except for those connecting the EN-100L to the Ethernet Jack. This is required in order to maintain the creepage and clearance distances.

The dimensions of the hatched area are based upon requirements for realising two means of patient protection (MOPP) for medical electrical (ME) devices. For such ME applications, those with operating voltages of up to 250 V AC require the dimensions indicated in Figure 6 to be met or exceeded, and those with operating voltages of up to 400 V AC require the dimensions indicated in parentheses in Figure 6 to be met or exceeded.

However, the actual requirements for the clearance and creepage distances vary with device and application, and must be determined and verified. The assembly of the Network Isolator in a manner that satisfies requirements and relevant standards is the responsibility of the device manufacturer.

5.3 EN-100S

5.3.1 EN-100S MODULE DIMENSIONS

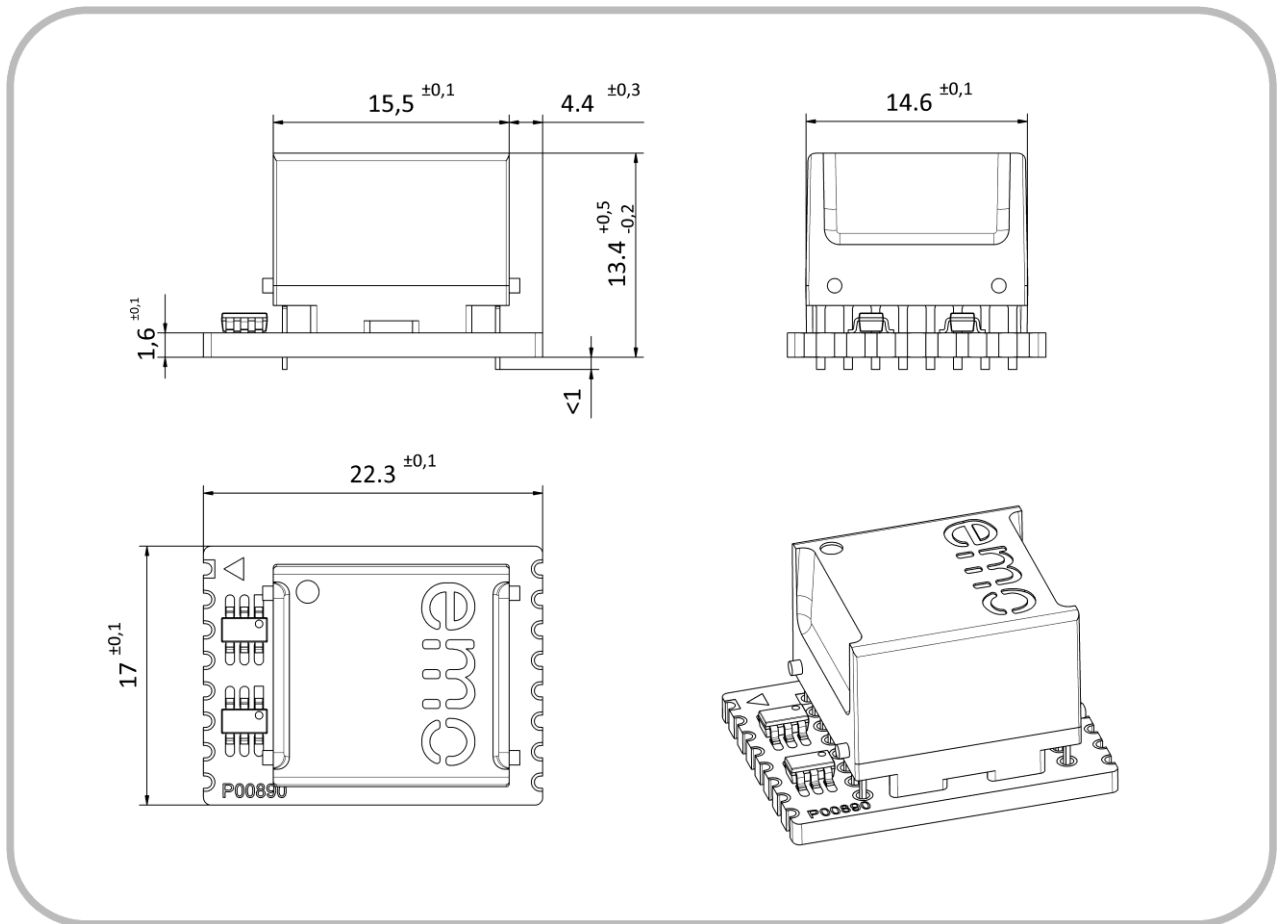

Figure 7. Physical dimensions of the EN-100S module.

5.3.2 EN-100S ASSEMBLY DIMENSIONS

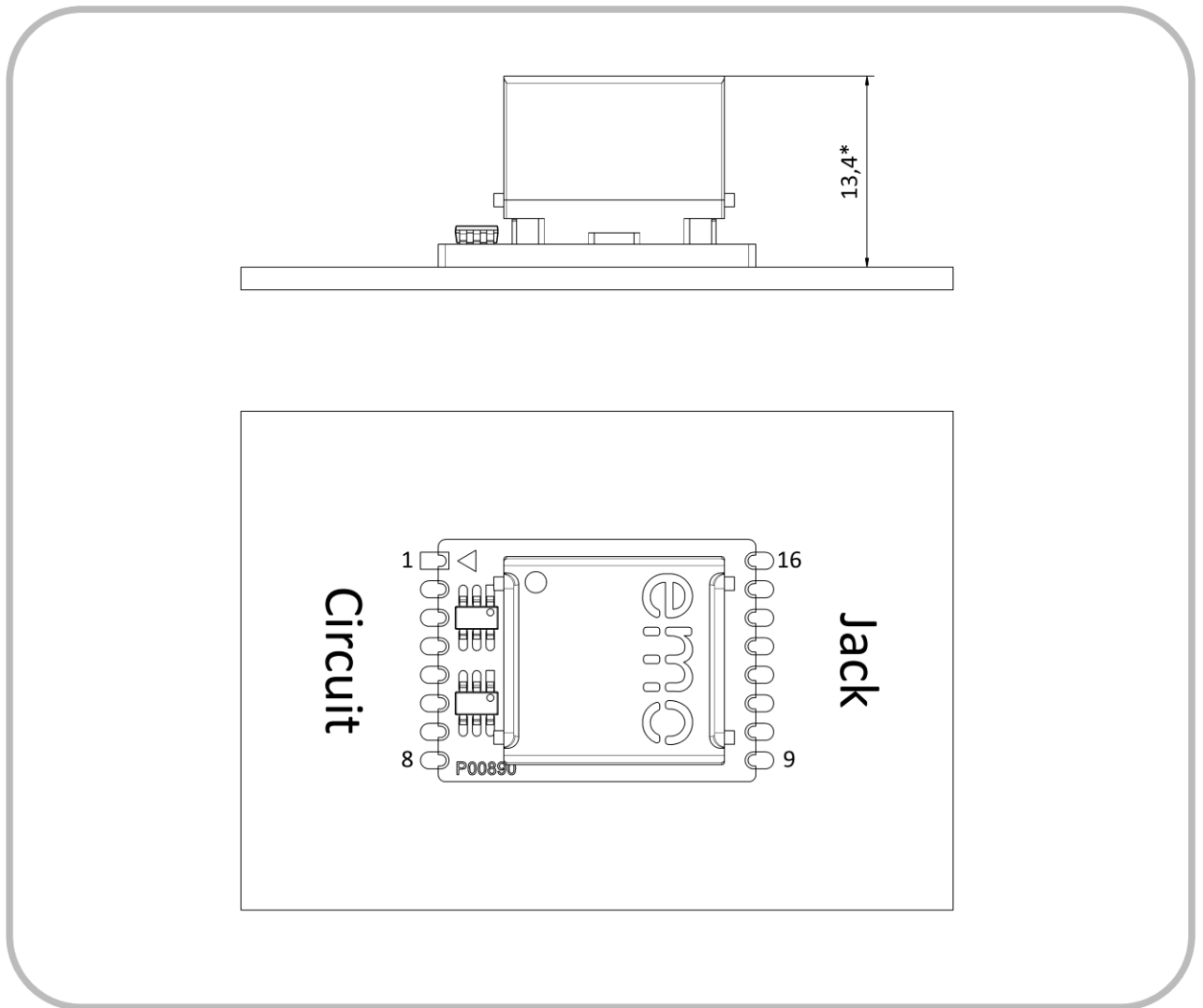

Figure 8. Physical dimensions of an EN-100S assembled onto a PCB.
The labels **Jack** and **Circuit** indicate the intended locations of the RJ45 Ethernet Jack and the product circuitry, respectively.

The EN-100S solder receptacles are suitable for population onto PCBs with surface-mount style pads, but must however be manually soldered. Refer to section **6 HANDLING AND ASSEMBLY NOTES**.

* The resulting component height of 13.4 mm is an expected dimension, and serves only as an indication.

5.3.3 EN-100S PCB LAYOUT

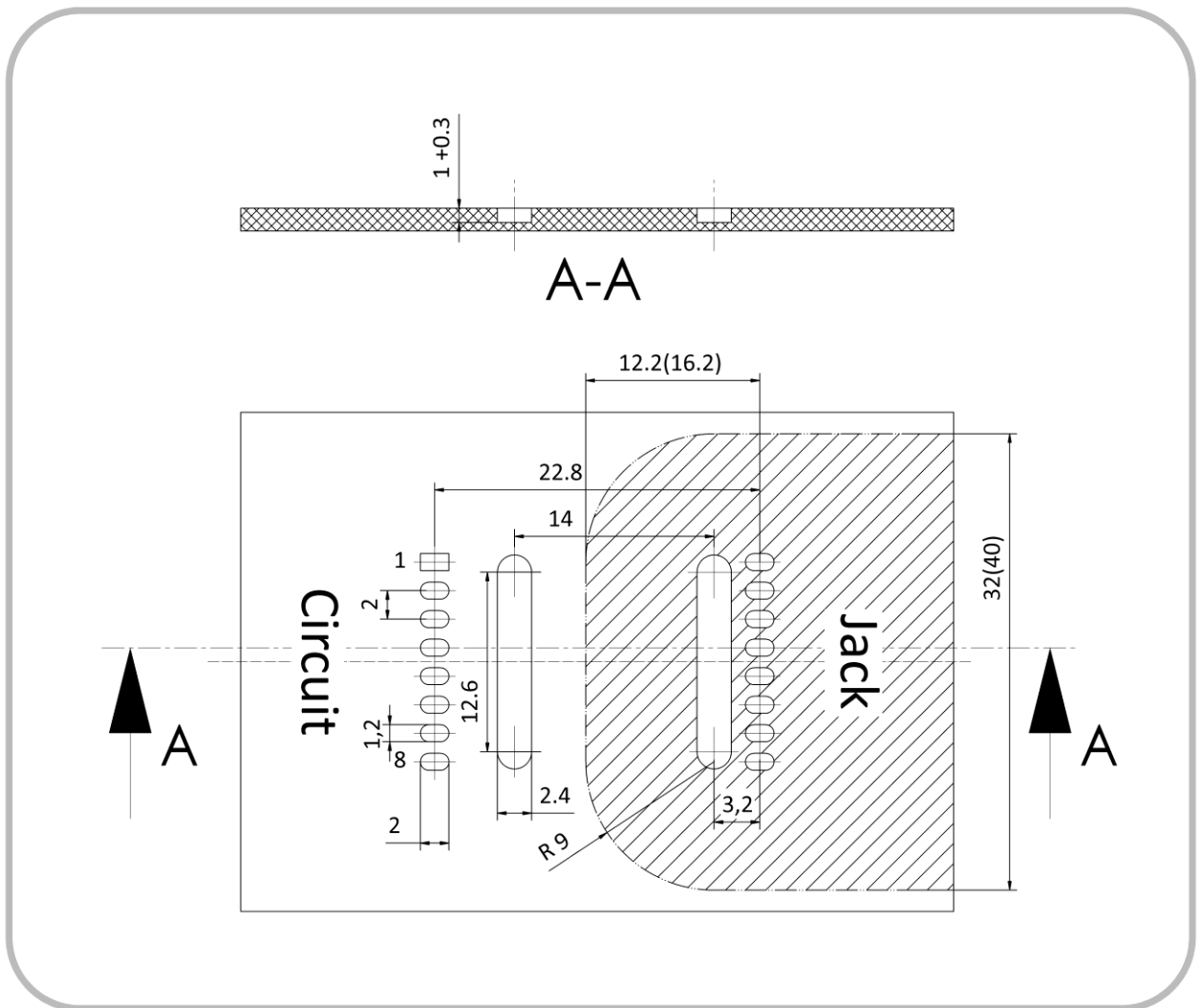

Figure 9. Suggested PCB layout for the EN-100S.

Pay careful attention to the two required Z-milling / cut-out areas, as detailed.

Dimensions in parentheses indicate the clearances required for environments with voltages up to 400 V AC.

Z-milling to a depth of 1 +0.3 mm is required in the rounded rectangular areas as shown in Figure 9, to accommodate the EN-100S.

PCB traces and other conducting surfaces must not be present in the hatched area, except for those connecting the EN-100S to the Ethernet Jack. This is required in order to maintain the creepage and clearance distances.

The dimensions of the hatched area are based upon requirements for realising two means of patient protection (MOPP) for medical electrical (ME) devices. For such ME applications, those with operating voltages of up to 250 V AC require the dimensions indicated in Figure 9 to be met or exceeded, and those with operating voltages of up to 400 V AC require the dimensions indicated in parentheses in Figure 9 to be met or exceeded.

However, the actual requirements for the clearance and creepage distances vary with device and application, and must be determined and verified. The assembly of the Network Isolator in a manner that satisfies requirements and relevant standards is the responsibility of the device manufacturer.

5.4 EN-100C

5.4.1 EN-100C MODULE DIMENSIONS

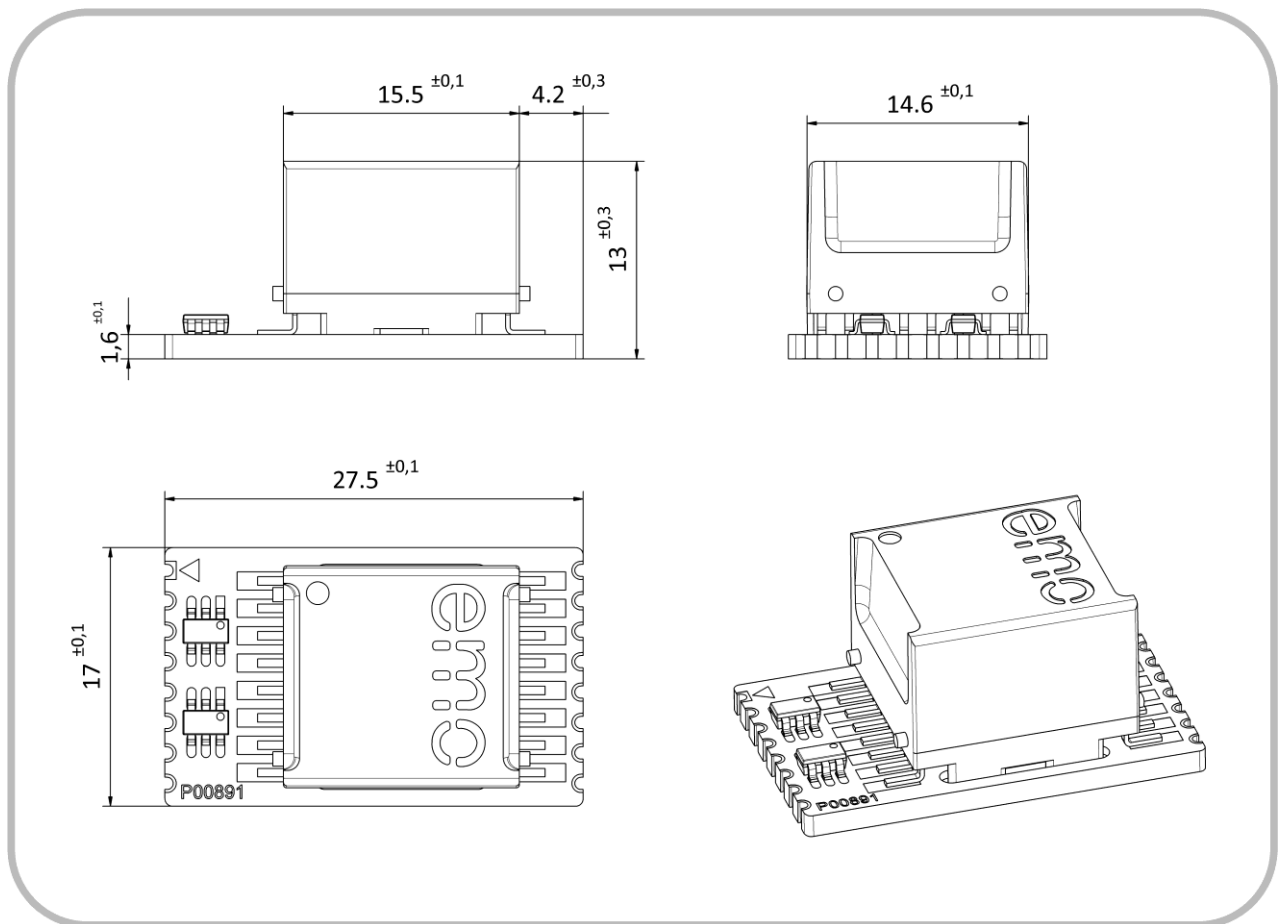

Figure 10. Physical dimensions of the EN-100C module.

5.4.2 EN-100C ASSEMBLY DIMENSIONS

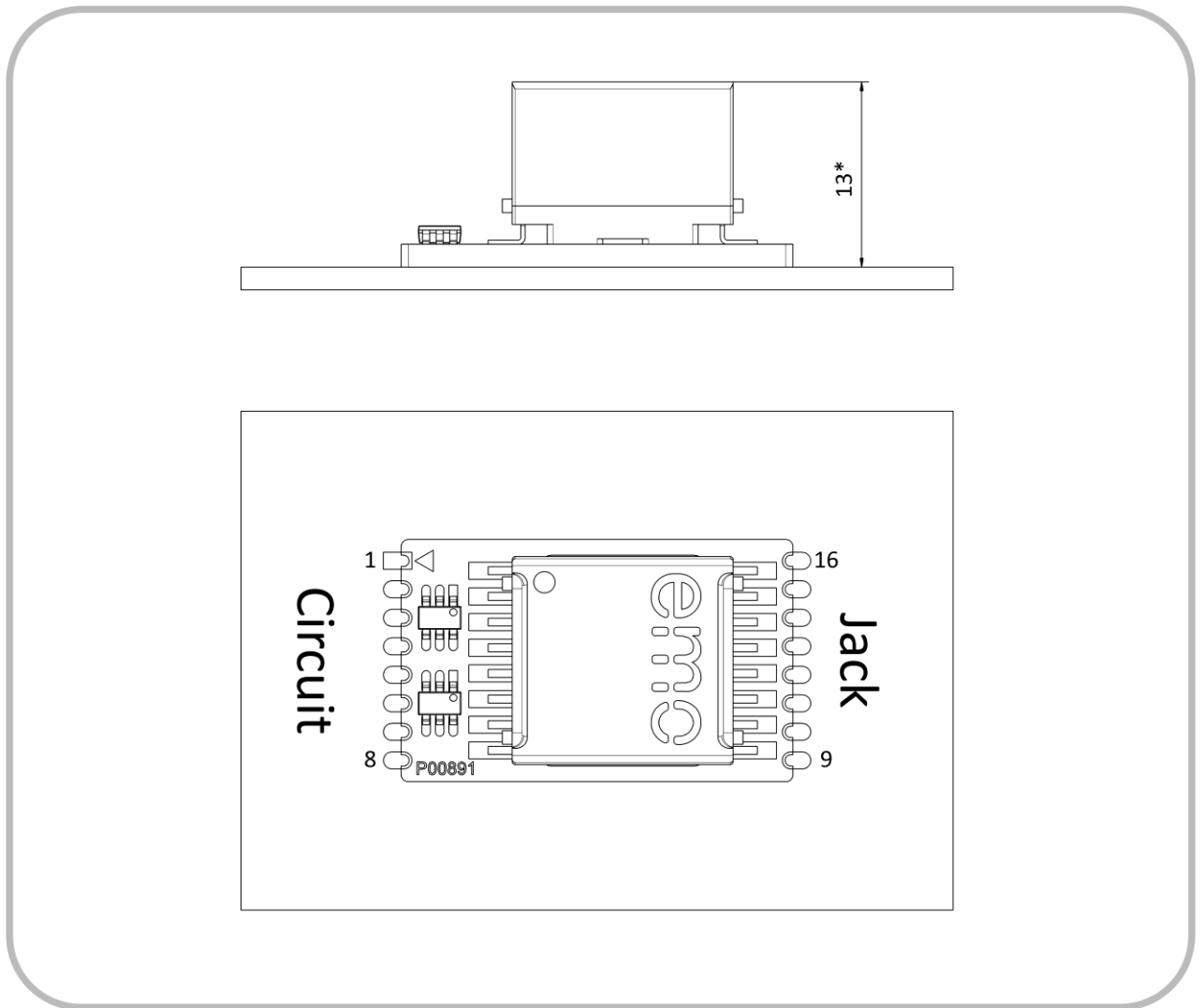

Figure 11. Physical dimensions of an EN-100C assembled onto a PCB.
The labels **Jack** and **Circuit** indicate the intended locations of the RJ45 Ethernet Jack and the product circuitry, respectively.

The EN-100C solder receptacles are suitable for population onto PCBs with surface-mount style pads, but must however be manually soldered. Refer to section **6 HANDLING AND ASSEMBLY NOTES**.

* The resulting component height of 13 mm is an expected dimension, and serves only as an indication.

5.4.3 EN-100C PCB LAYOUT

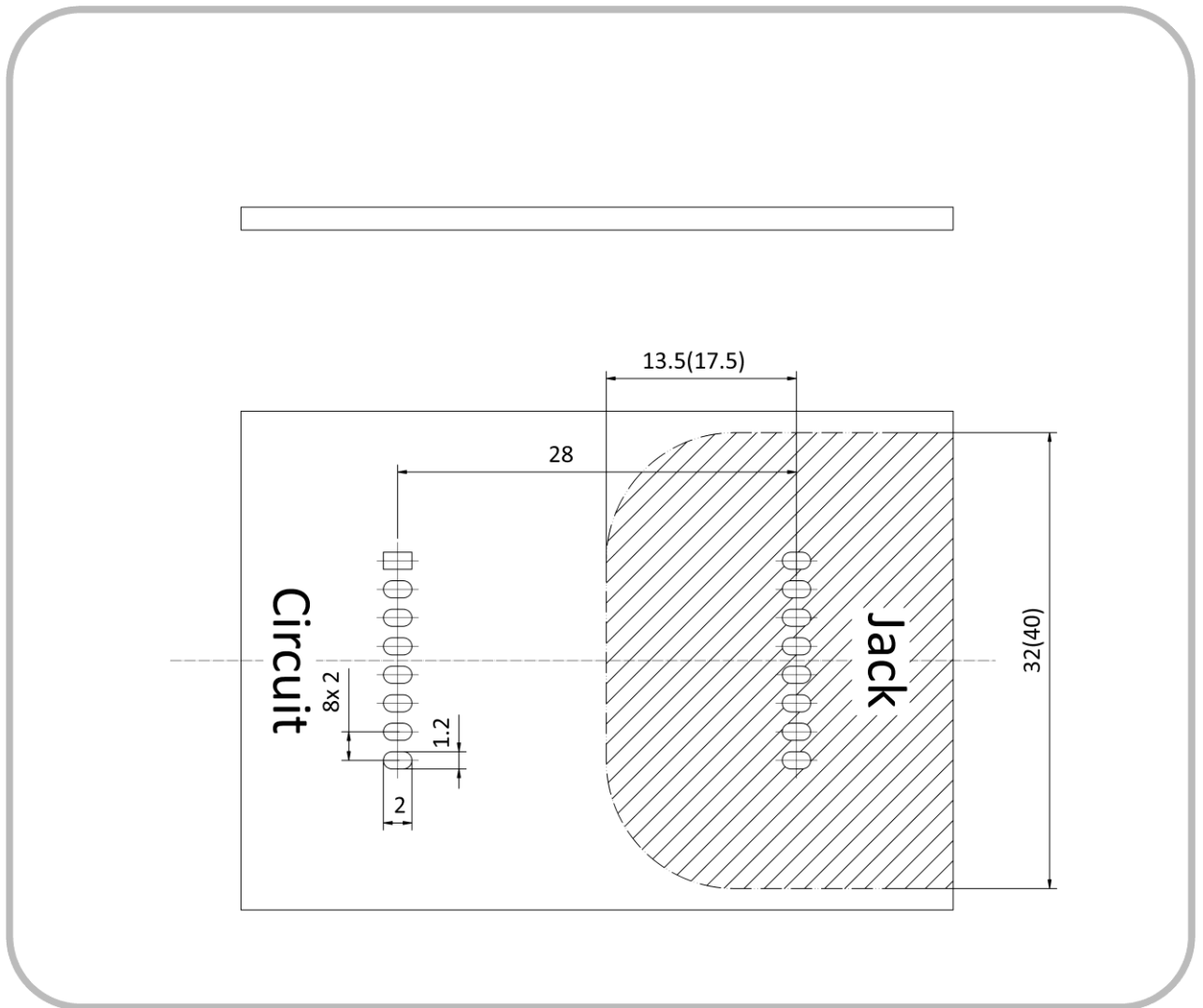

Figure 12. Suggested PCB layout for the EN-100C.
 Dimensions in parentheses indicate the clearances required for environments with voltages up to 400 V AC.

PCB traces and other conducting surfaces must not be present in the hatched area, except for those connecting the EN-100C to the Ethernet Jack. This is required in order to maintain the creepage and clearance distances.

The dimensions of the hatched area are based upon requirements for realising two means of patient protection (MOPP) for medical electrical (ME) devices. For such ME applications, those with operating voltages of up to 250 V AC require the dimensions indicated in Figure 12 to be met or exceeded, and those with operating voltages of up to 400 V AC require the dimensions indicated in parentheses in Figure 12 to be met or exceeded.

However, the actual requirements for the clearance and creepage distances vary with device and application, and must be determined and verified. The assembly of the Network Isolator in a manner that satisfies requirements and relevant standards is the responsibility of the device manufacturer.

6 HANDLING AND ASSEMBLY NOTES

EN-100 Network Isolators are intended for manual soldering only. Assembly procedures using reflow ovens or wave soldering baths are not permissible as they may cause thermal damage to the potting material inside the transformer. Avoid exposing the transformer to ambient temperatures greater than 85°C.

7 APPLICATION INFORMATION

The EN-100 Network Isolators are designed for data transmission in the frequency range of 300 kHz to 100 MHz. Lower frequencies are strongly attenuated. For this reason, it is generally not possible to transmit the signals from nurse call systems, telephone systems or analogue audio / video signals over a Network Isolator.

The EN-100 Network Isolator can be used in a Power over Ethernet (PoE) network without restriction (however PoE devices downstream of the electrical isolation are not supplied with power).

8 SAFETY NOTICE

8.1 SAFETY INSPECTIONS

For the device or application fitted with EN-100, the test interval, as well as the requirements to be met for both regular safety inspections and post-repair inspections will be specified by the responsible organisation (e.g. manufacturer or operator as defined by the regulations), and based upon the applicable standards for the entire system.

8.2 CREEPAGE AND CLEARANCE DISTANCES

PCB layouts and applications that utilise EN-100 Network Isolators must be designed to meet or exceed the requirements of all applicable standards (for example, IEC 60601-1). Special attention must be paid to the required creepage and clearance distances.

9 SPECIFICATIONS

9.1 GENERAL

Category	Standards or Test Criteria	Properties
Designation		EMOSAFE EN-100
Construction		PCB Assembly
Mounting Arrangement		EN-100T, EN-100L: Soldering, plugging EN-100C, EN-100S: Soldering
Input Interface		EN-100T, EN-100L: 2 mm pin header EN-100C, EN-100S: Solder pad
Output Interface		EN-100T, EN-100L: 2 mm pin header EN-100C, EN-100S: Solder pad
Weight		approximately 6 g
Mean Time To Failure (MTTF)	SN 29500 Standard Temperature: 25°C Duty cycle: 100% (24 hours, 7 days)	3,250 years
	SN 29500 Standard Temperature: 40°C Duty cycle: 100% (24 hours, 7 days)	3,080 years

9.2 ETHERNET PERFORMANCE

Category	Standards or Test Criteria	EN-100
Transmission Speeds and Supported Network Protocols	10 Mbit/s, 10Base-T (IEEE802.3 Cl.14)	✓
	100 Mbit/s, 100Base-Tx (IEEE802.3 Cl.25)	✓
	1000 Mbit/s, 1000Base-T (IEEE802.3 Cl.40)	✓
Performance Category	ISO 11801, Permanent Link (PL)	Class D
Insertion Loss (absolute)	Typical:	0.8 dB @ 100 MHz
	Maximum:	1.0 dB @ 100 MHz
Return Loss (absolute)	Typical:	17.0 dB @ 100 MHz
	Minimum:	14.0 dB @ 100 MHz

9.3 ELECTRICAL

Category	Standards or Test Criteria		EN-100
AC Dielectric Strength	at 50 Hz, for 60 seconds		4.6 kV
DC Dielectric Strength	for 60 seconds		8.5 kV
Reinforced Isolation	IEC 60601-1		✓
Coupling Capacitance per Channel			37.5 pF ±25%
Total Coupling Capacitance			150 pF ±25%
Total Leakage Current	275 V AC at 50 Hz	Typical:	12.0 µA
		Maximum:	16.0 µA
TVS diode circuitry	Suppression of transients on the signal lines		✓

9.4 OPERATING CONDITIONS AND AREA OF APPLICATION

Category	Standards or Test Criteria		EN-100
Pollution Degree	IEC 61010		2 *
Overvoltage Category	IEC 60664-1		III
Maximum Working Voltage †	Maximum mains voltage of the connected devices, in accordance with IEC 60601-1		400 V AC 450 V DC
Temperature		Minimum:	-10°C
		Maximum:	+70°C
Air Humidity	Non-condensing	Minimum:	10%
		Maximum:	90%
Air Pressure		Minimum:	700 hPa
		Maximum:	1,060 hPa
Altitude		Maximum:	3,200 m

9.5 ENVIRONMENTAL CONDITIONS: STORAGE AND TRANSPORTATION

Category	Standards or Test Criteria		EN-100
Temperature		Minimum:	-40°C
		Maximum:	+70°C
Air Humidity	Non-condensing	Minimum:	10%
		Maximum:	90%
Air Pressure		Minimum:	500 hPa
		Maximum:	1,060 hPa

* Normally only nonconductive pollution occurs. Temporary conductivity caused by condensation is to be expected.

† The Network Isolator can be permanently exposed to this voltage level.

9.6 CERTIFICATES

All Network Isolators from EMO Systems GmbH are additionally registered by UL International as Recognized Components, under the file numbers E249126 and E362969. They are therefore suitable for application in American and Canadian markets.

Furthermore, the compliance of our Network Isolators with the standard specifications IEC 60601-1 (3rd Ed.), ANSI/AAMI ES60601-1 and CAN/CSA-C22.2 No. 60601-1 has been confirmed by an independent, accredited laboratory. To view a copy of these certificates, please visit the [UL Online Directory](#) or contact us directly.

The certification of our products to the requirements of the IEC 60601-1-2 has also been confirmed by an external laboratory. The test report can be obtained upon request.

Our Declaration of Conformity can be found on our website, which confirms the compliance of our products with the requirements of the Low Voltage Directive, the Electromagnetic Compatibility Directive, and the Restriction of Hazardous Substances Directive (RoHS).

Category	Standards or Test Criteria	EN-100
UL Recognized Component		✓
UL File No.		E246126 E362969
IEC 60601-1	Complies with the requirements of a galvanic separator in accordance with IEC 60601-1 (Ed. 3.1)	✓
IEC 60601-1-2	Complies with the requirements of IEC 60601-1-2	✓
ANSI/AAMI ES 60601-1	Complies with the requirements of ANSI/AAMI ES60601-1	✓
CAN/CSA-C22.2 No. 60601-1	Complies with the requirements of CAN/CSA-C22.2 No. 60601-1	✓
Low Voltage Directive	Complies with the requirements of the directive 2014/35/EU	✓
EMC Directive	Complies with the requirements of the directive 2004/108/EU	✓
RoHS Directive	Complies with the requirements of the directive 2011/65/EU	✓
Lead-free	Contains no lead-containing substances, and is manufactured with lead-free solder	✓

9.7 ISOLATION DIAGRAM

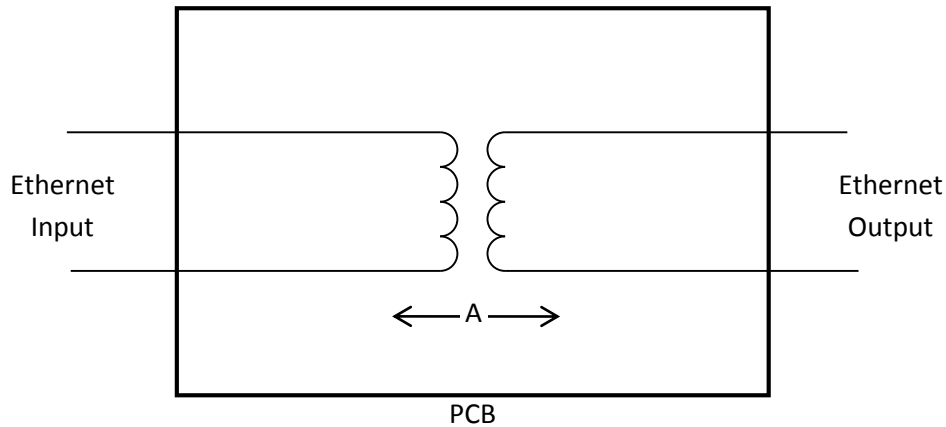

Figure 13. Isolation diagram of an EN-100 Network Isolator. Applies to all variants.

Area	Number and type of Means of Protection	Material Group (from CTI)	Maximum Operating Voltage		Required creepage distance (mm)	Required clearance distance (mm)	Measured creepage distance (mm)	Measured clearance distance (mm)
			V AC	V _{peak}				
A	2 MOPP *	IIIb †	400	565	12.0	7.0	12.5	12.5

9.8 FREQUENCY RESPONSE

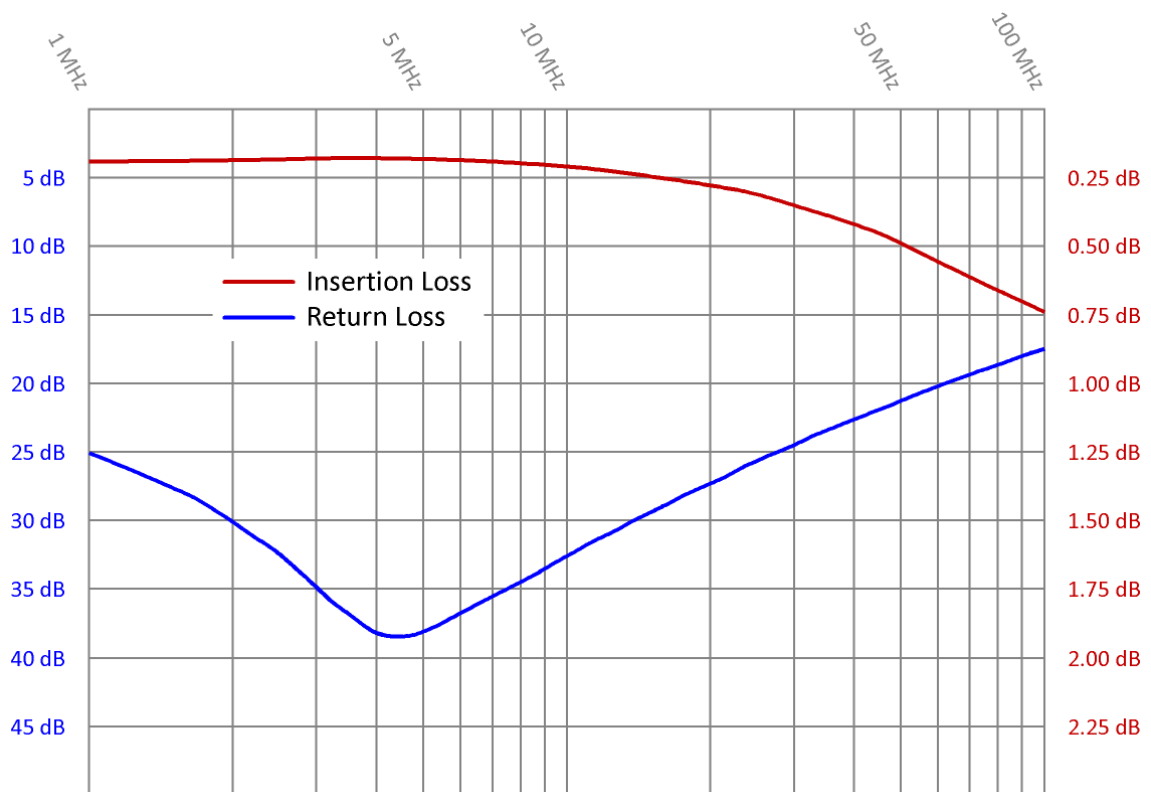

Figure 14. Typical frequency response for Insertion Loss and Return Loss of an EMOSAFE EN-100C Network Isolator.

* MOPP = Means of Patient Protection

† Materials in the Material Group IIIb have a Comparative Tracking Index (CTI) value between 100 and 175.

10 CIRCUIT DIAGRAM

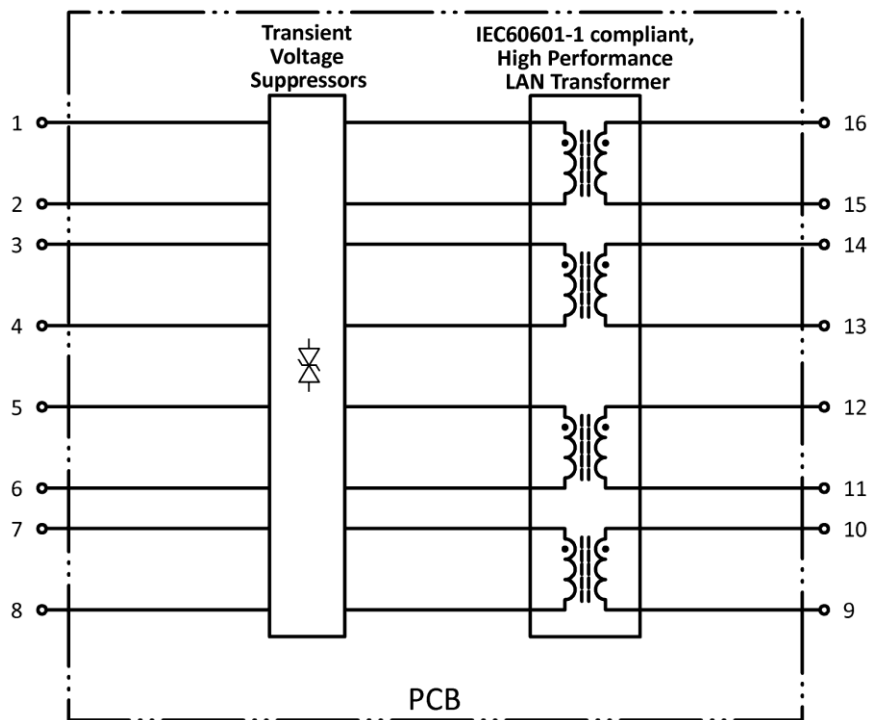

Figure 15. Circuit diagram for all EN-100 variants.

11 PACKAGING





Contents:

- Network Isolator. One of: EN-100C, EN-100L, EN-100S, EN-100T

A packaging label provides the following information:

- Article description
- Quantity
- Date of Manufacture
- Serial number
- The serial number is printed as a 1D- (Code 128) and 2D barcode (Data Matrix).

12 PRODUCT MARKINGS

	This mark certifies conformity of the product with all applicable EU Directives.
	Designates the product as a UL "Recognised Component"; File number E249126 and E362969.
	The product may not be disposed of in domestic waste.
	This product contains no substances containing lead, and is manufactured using lead-free solder.
	This product meets the requirements of EU Directive concerning the limitation of the use of certain hazardous substances in electrical and electronic equipment.

13 MAINTENANCE

When used as directed, EMOSAFE Network Isolators are maintenance-free.

14 ENVIRONMENTAL PROTECTION INFORMATION

This device contains electronic components. At the end of its service life, it is to be returned to the manufacturer for disposal.

15 QUALITY

EMO Systems operates a certified quality management system for development and production in accordance with ISO 9001 and ISO 13485. Prior to delivery, each Network Isolator is subjected to a comprehensive quality inspection. This inspection ensures, among other factors, that the attained values for leakage currents, dielectric withstand strengths, insertion losses, return losses, and near end crosstalk values all meet the specified requirements.

16 CONTACT AND SUPPORT

Please find our up-to-date contact details on our website: <http://www.emosystems.de/en/contact>

Or send us an e-mail at the following address: support@emosystems.de

17 LEGAL NOTICE

The information provided above in this datasheet has been compiled with all due care, and is believed to be accurate and reliable. However, we cannot guarantee that the information contained is completely free from error. The end user is responsible and liable for the proper use of this product; EMO Systems assume no liability. We reserve the right to make changes to this datasheet without notice.

X-ON Electronics

Largest Supplier of Electrical and Electronic Components

Click to view similar products for [Audio Transformers / Signal Transformers](#) category:

Click to view products by [EMO Systems](#) manufacturer:

Other Similar products are found below :

[CX2041NLT](#) [MGPWT-00449-P](#) [PE-64961](#) [H1302FNLT](#) [H5008FNL](#) [H5012FNL](#) [H5020FNLT](#) [H5077NLT](#) [H5079NLT](#) [H5084FNLT](#)
[B78476A9558A003](#) [1812WBT2-4](#) [1879479-1](#) [HX2260FNL](#) [HX5014FNL](#) [EX2024FNL](#) [FL1066](#) [T1137NLT](#) [T3012NL](#) [PE-65812FNL](#) [PE-65848FNLT](#) [H1174FNL](#) [H1302FNL](#) [H5015FNL](#) [H5019EFNL](#) [H5062FNLT](#) [CX2047LNL](#) [MGPWT-00059-P](#) [MGPWT-00266-P](#) [MGPWT-00278-P](#) [MGPWT-00431-P](#) [TTC-100](#) [TTC-143-H](#) [TTC-5032-1](#) [BX1194WNLT](#) [HX1234NLT](#) [HX5008FNLT](#) [HX5019FNL](#) [HX5084NL](#) [3-1879385-5](#) [TX1263NLT](#) [4-1879391-0](#) [T1142NL](#) [HX6101FNL](#) [HX5084FNL](#) [HX1148NL](#) [HX5020FNLT](#) [HX5014FNLT](#) [T1124NL](#)
[1879732-1](#)