

PRODUCT SPECIFICATION

SPEC. NO: T-0621-002P

DATE: Aug. 21, 2018

CUSTOMER'S PRODUCT NAME:

EMTEK PRODUCT NAME:

HQC0805-Series

THIS SPECIFICATION IS:

- FULLY ACCEPTED
- DENIED
- ACCEPTED UNDER THE FOLLOWING CONDITIONS



SIGNATURE: _____

DATE: _____

NAME(PRINT): _____

TITLE: _____

 **EMTEK CO., LTD.**

本文件內容全部或部份,未經兆欣科技股份有限公司同意不得以何形式複製或其他用途

All rights reserved.This document or parts thereof,may not be reproduced by any means or used in any manner without written permission of EMTEK CO.,LTD.

FACTORY:

39, Chingao Rd., (305)Hsinpu,
Hsinchu Hsien, Taiwan, R. O. C

TEL: 03-5894-433

FAX: 03-5894-523

PRODUCT SPECIFICATION

SPEC. NO.

T-0621-002P



1. Scope

This specification applies Ceramic Chip Inductance HQC0805-Series to be delivered to user.

2. Product Identification

HQC 0805 - 12N □ - T

(1) (2) (3) (4) (5)

- (1) Product name
- (2) Shapes and dimensions
- (3) Inductance
12N : 12 nH
- (4) Tolerance
G=±2% , J=±5% , K=±10%
- (5) Taping Type

3. Shapes and Dimensions

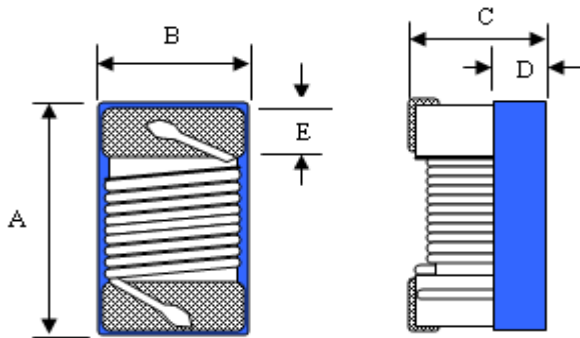

- A max. : 2.40 mm
- B max. : 1.65 mm
- C max. : 1.45 mm
- D ref. : 0.65 mm
- E : 0.44 mm

Equivalent circuit

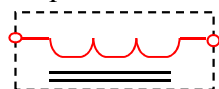

No Polarity

Drawn by	Checked by	Approved by
Gindy Sep. 29. 2017	Zheny Sep. 29. 2017	Su Sep. 29. 2017

PRODUCT SPECIFICATION

SPEC. NO.

T-0621-002P



4. Electrical Characteristics

Customer Part Number	Our Product Part Number	Inductance (nH)/MHz	Inductance Tolerance	Q/MHz Min.	SRF(Min.) (MHz)	DCR (Ω)Max.	Irms Max. (mA)	Color Coding
	HQC0805-2N5□-T	2.5/250		60/1500	>6000	0.030	1600	Black
			J					
			K					
	HQC0805-5N6□-T	5.6/250		98/1500	>6000	0.035	1600	Brown
			J					
			K					
	HQC0805-6N2□-T	6.2/250		70/1000	4750	0.035	1600	Red
			J					
			K					
	HQC0805-10N□-T	10/250		75/1000	3000	0.050	1600	Gray
			J					
			K					
	HQC0805-12N□-T	12/250	G	80/1000	3000	0.050	1600	Orange
			J					
			K					
	HQC0805-15N□-T	15/250	G	72/500	2950	0.080	1500	White
			J					
			K					
	HQC0805-16N□-T	16/250	G	72/500	2950	0.060	1500	Yellow
			J					
			K					
	HQC0805-18N□-T	18/250	G	75/500	2550	0.065	1400	Green
			J					
			K					
	HQC0805-20N□-T	20/250	G	70/500	2050	0.065	1400	Blue
			J					
			K					
	HQC0805-22N□-T	22/250	G	70/500	2050	0.075	1400	Red
			J					
			K					
	HQC0805-27N□-T	27/250	G	75/500	2000	0.075	1300	Violet
			J					
			K					
	HQC0805-30N□-T	30/250	G	65/500	1950	0.095	1200	Gray
			J					
			K					
	HQC0805-33N□-T	33/250	G	65/500	1800	0.100	1200	Orange
			J					
			K					
	HQC0805-39N□-T	39/250	G	65/500	1600	0.100	1100	White
			J					
			K					
	HQC0805-43N□-T	43/200	G	65/500	1500	0.110	1100	Yellow
			J					
			K					
	HQC0805-47N□-T	47/200	G	65/500	1400	0.105	1200	Green
			J					
			K					
	HQC0805-48N□-T	48/200	G	65/500	1400	0.100	1200	Black
			J					
			K					

PRODUCT SPECIFICATION

SPEC. NO.

T-0621-002P



4. Electrical Characteristics

Customer Part Number	Our Product Part Number	Inductance (nH)/MHz	Inductance Tolerance	Q/MHz Min.	SRF(Min.) (MHz)	DCR (Ω)Max.	Irms Max. (mA)	Color Coding
	HQC0805-51N□-T	51/200	G	65/500	1400	0.120	1000	Brown
			J					
			K					
	HQC0805-56N□-T	56/200	G	65/500	1400	0.16	900	Blue
			J					
			K					
	HQC0805-82N□-T	82/200	/	65/500	1400	0.20	800	Red
			J					
			K					
	HQC0805-R10□-T	100/150	/	55/500	1300	0.29	700	Black
			J					
			K					
	HQC0805-R12□-T	120/150	/	55/250	1300	0.510	700	Red
			J					
			K					
	HQC0805-R15□-T	150/100	/	55/250	1300	0.540	650	Green
			J					
			K					
	HQC0805-R18□-T	180/100	/	55/250	1300	0.600	600	Gray
			J					
			K					

1. When ordering, please specify tolerance and packaging codes. Ex: HQC0805-12NJ-T

Tolerance : G = $\pm 2\%$, J = $\pm 5\%$, K = $\pm 10\%$

Packaging : Clear tape and reel { standard }.

2. L , Q · SRF : Agilent/HP E4991A+ Agilent/HP16197A

(The electrical specification test by the smallest gap position) or HP16193A

3. Rdc : DIGITAL MILLIOHM METER Chroma 16502, or equivalent.

4. Irms for a 15°C rise above 25°C ambient.

5. Operating temperature range from -40°C to 125°C.

1st Code

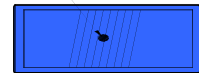

COLOR CODING

PRODUCT SPECIFICATION

SPEC. NO.

T-0621-002P

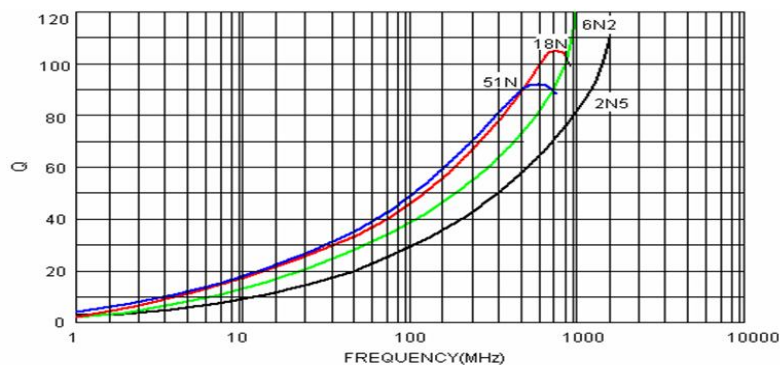
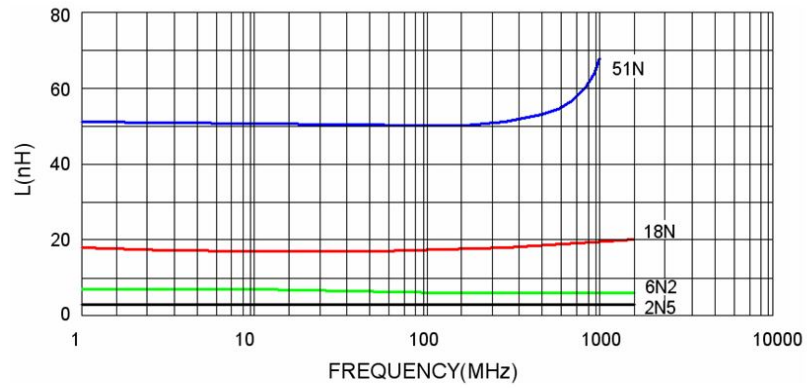

5. Material list

Item	Material
Core	Al2O3 96%
Wire	Copper wire
Epoxy	UV Eopxy

PRODUCT SPECIFICATION

SPEC. NO.

T-0621-002P



6. Reliability Test

Item	Specifications	Test conditions
Solderability	The metalized area must have 90% minimum solder coverage.	Dip pads in flux and dip in solder pot(96.5 Sn/3.5 Ag solder) at 255°C ±5°C.
Resistance to soldering heat	There must be no case deformation or change in dimensions. Inductance must not change more than the stated tolerance.	Inductors shall be reflowed onto a PC board using 96.5 Sn/3.5 Ag solder paste. Solder process shall be at a maximum temperature of 260°C. For 96.5 Sn/3.5 Ag solder paste:>217°C for 90 seconds
Vibration	There must be no case deformation or change in dimensions. Inductance must not change more than the stated tolerance.	Solder specimen inductor on the test printed circuit board. Apply vibrations in each of the x,y and z directions for 2 hours for a total of 6 hours. Frequency : 10~50 Hz Amplitude : 1.5mm
High temperature resistance	There must be no case deformation or change in dimensions. Inductance must not change more than the stated tolerance.	Inductors shall be subjected to temperature 125±2°C for 50±12 hours. Measure the test items after leaving the inductors at room temperature and humidity for 2 hours.
Static Humidity	Inductors must not have a shorted or openwinding.	Inductors shall be subjected to temperature 85±2°C and 90 to 95%RH. for ten 24-hours. Measure the test items after leaving the inductors at room temperature and humidity for 2 hours.
Component adhesion (push test)	Inductors shall be subjected to 1.8Kg	Inductors shall be reflow soldered (255°C ±5°C for 10 seconds) to a tinned copper substrate. A force gauge shall be applied to the side of the component. The device must withstand the stated force without a failure of the termination.

PRODUCT SPECIFICATION

SPEC. NO.

T-0621-002P

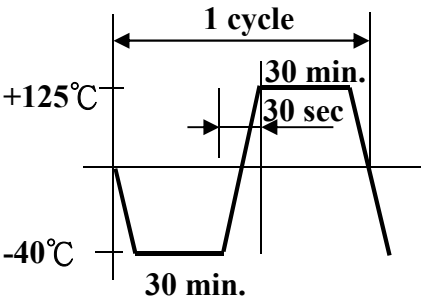

Item	Specifications	Test conditions
Low temperature resistance	There must be no case deformation or change in dimensions. Inductance must not change more than the stated tolerance.	Inductors shall be subjected to temperature $-40\pm 2^{\circ}\text{C}$ for 48 ± 12 hours. Measure the test items after leaving the inductors at room temperature and humidity for 1 to 2 hours.
Resistance to solvent	There must be no case deformation, change in dimensions, or obliteration of marking.	Inductors must withstand 6 minutes of alcohol or water.
Thermal shock	There must be no case deformation or change in dimensions. Inductance must not change more than the stated tolerance.	Inductors shall be subjected to 10 cycles to the following temperature cycle: <div style="text-align: center;">  </div> Measure the test items after leaving the inductors at room temperature and humidity for 2 hours.

PRODUCT SPECIFICATION

SPEC. NO.

T-0621-002P



7. Packaging

The packaging must be done not to receive any damage during transporting and storing.

7-1 Tape dimensions

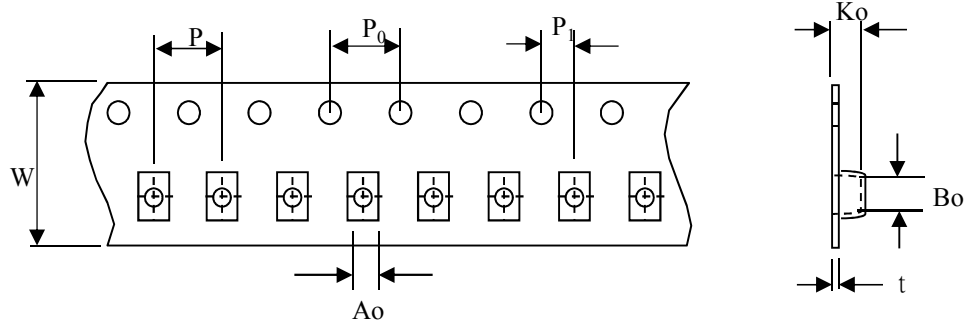

(Dimensions in mm; Tolerance : ±0.1)

Symbol	W	P	P ₀	P ₁	A _o	B _o	K _o	t
Dimension	8	4	4	2	1.57	2.28	1.4	0.22

7-2 Reel dimensions

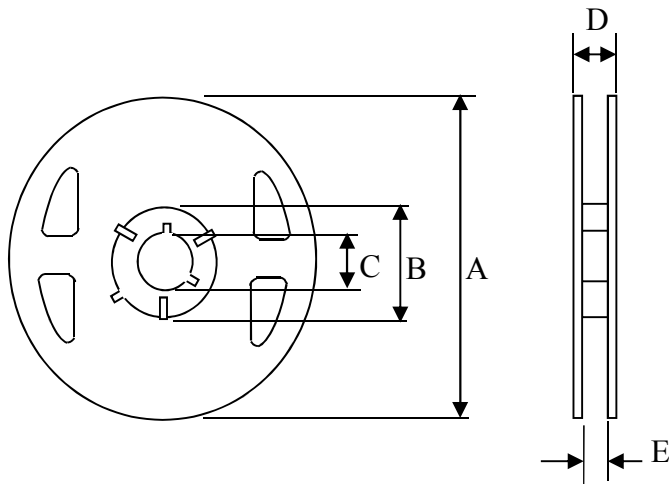

(Dimensions in mm)

Symbol	T
A	180
B	60
C	13
D	14.4
E	8.4

7-3 Tapping figure

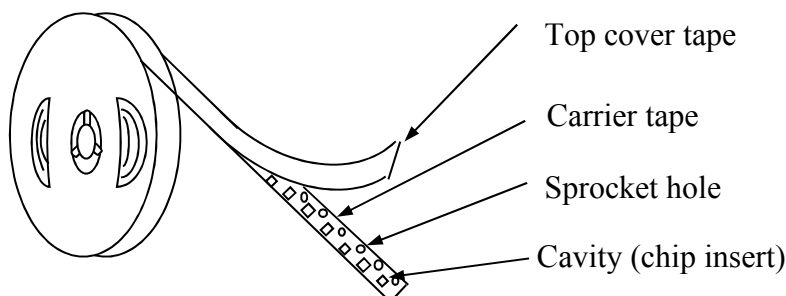

PRODUCT SPECIFICATION

SPEC. NO.

T-0621-002P



7-4 Packaging Form

There shall not continuation more than two vacancies of the product.

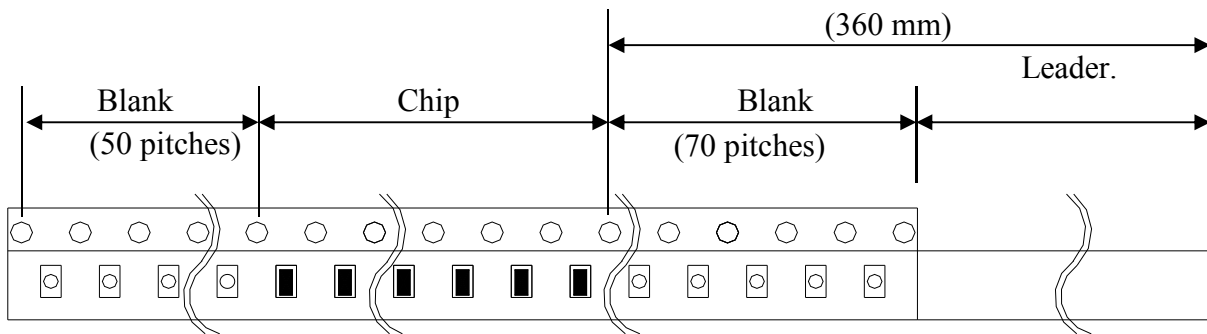

7-5 Cover Tape Peel Strength

The force for tearing off cover tape is 0.1~0.6(N) in the arrow direction at the following conditions:

Temperature : 5 ~ 35°C

Humidity : 45 ~ 85%

Atmospheric pressure : 860 ~ 1060 hpa

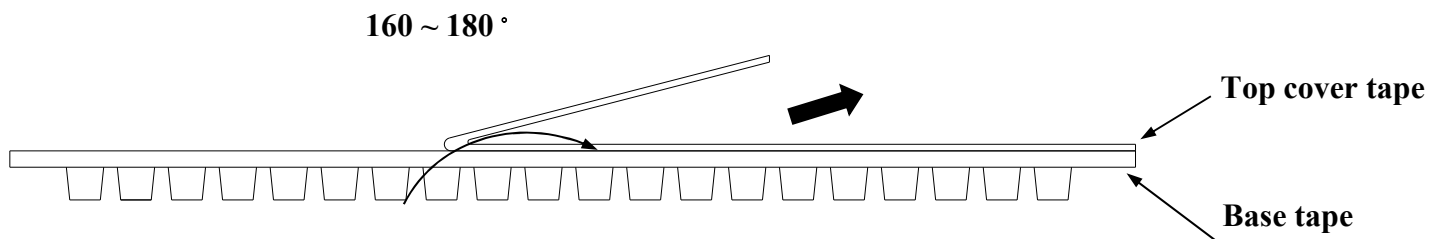

7-6 Packing Quantity

φ180 mm reel type : 2,000 pcs./reel

PRODUCT SPECIFICATION

SPEC. NO.

T-0621-002P



8. Recommended Soldering Conditions

(Please use this product by reflow soldering)

8-1 Recommended Footprint

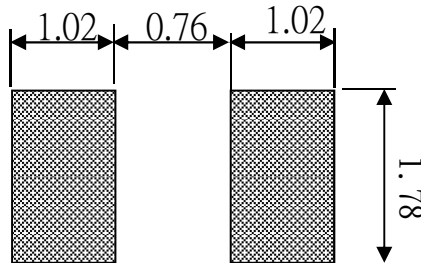

Unit: mm

8-2 Recommended Reflow Pattern

Reflow : until two times

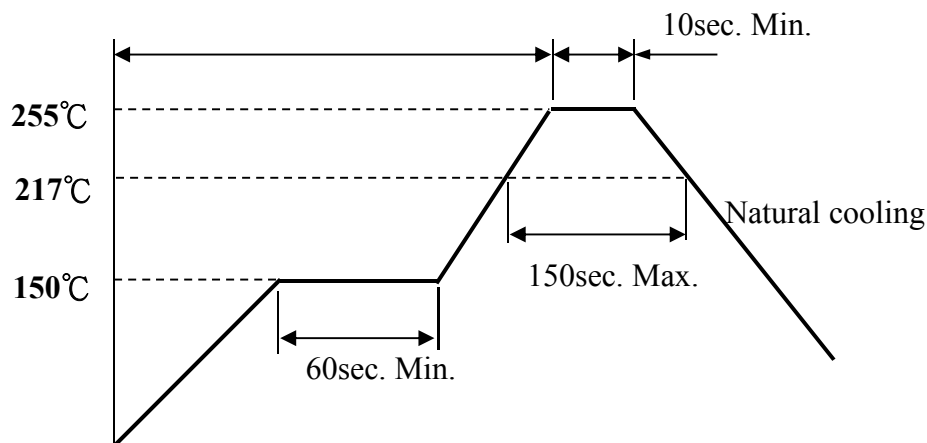

8-3 Iron Soldering

Use a solder iron of less than 30W when soldering, do not allow the soldering iron to directly touch the Ceramic body outside of terminal electrode.

5 seconds max. at 260°C.

9. Attention in Case of Using

In case of using product, please avoid following matters:

Splashing water or salt water

Dew condenses

Toxic gas (Hydrogen sulfide, Sulfurous acid, Chlorine, Ammonia)

Vibrations or shocks which exceed the specified condition

Please be careful for the stress to this product by board flexure or something after the mounting.

10. Others

10-1 Operating temperature range : Ceramic Series : -40~+125°C

10-2 Storage condition : Temperature 20°~25°C, Relative Humidity 40%~60%

10-3 Recommended wire wound inductors should be used within 6 months from the time of delivery.

X-ON Electronics

Largest Supplier of Electrical and Electronic Components

Click to view similar products for [Fixed Inductors](#) category:

Click to view products by [EMTEK](#) manufacturer:

Other Similar products are found below :

[CR32NP-100KC](#) [CR32NP-151KC](#) [CR32NP-180KC](#) [CR32NP-181KC](#) [CR32NP-1R5MC](#) [CR32NP-390KC](#) [CR32NP-3R9MC](#) [CR32NP-680KC](#) [CR32NP-820KC](#) [CR32NP-8R2MC](#) [CR43NP-390KC](#) [CR43NP-560KC](#) [CR43NP-680KC](#) [CR54NP-181KC](#) [CR54NP-470LC](#) [CR54NP-820KC](#) [CR54NP-8R5MC](#) [70F224AI](#) [MGDQ4-00004-P](#) [MHL1ECTTP18NJ](#) [MHQ1005P10NJ](#) [MHQ1005P1N0S](#) [MHQ1005P2N4S](#) [MHQ1005P3N6S](#) [MHQ1005P5N1S](#) [MHQ1005P8N2J](#) [PE-51506NL](#) [PE-53601NL](#) [PE-53602NL](#) [PE-53630NL](#) [PE-53824SNLT](#) [PE-92100NL](#) [PG0434.801NLT](#) [PG0936.113NLT](#) [9220-20](#) [9310-16](#) [PM06-2N7](#) [PM06-39NJ](#) [A01TK](#) [1206CS-471XJ](#) [HC2LP-R47-R](#) [HC2-R47-R](#) [HC3-2R2-R](#) [HCF1305-3R3-R](#) [1206CS-151XG](#) [RCH664NP-140L](#) [RCH664NP-4R7M](#) [RCH8011NP-221L](#) [RCP1317NP-332L](#) [RCP1317NP-391L](#)