

PRODUCT SPECIFICATION

SPEC. NO: T-0619-003r

DATE: Aug. 21, 2018

CUSTOMER' S PRODUCT NAME:

EMTEK PRODUCT NAME:

HSC0603-SERIES

THIS SPECIFICATION IS:

- FULLY ACCEPTED
 DENIED
 ACCEPTED UNDER THE FOLLOWING CONDITIONS



SIGNATURE:

DATE:

NAME(PRINT):

TITLE:

 **EMTEK CO., LTD.**

本文件內容全部或部份,未經兆欣科技股份有限公司同意不得以任何形式複製或其他用途
All rights reserved.This document or parts thereof,may not be reproduced by any means or used in any manner without written permission of EMTEK CO.,LTD.

FACTORY:

39, Chingao Rd., (305)Hsinpu,
Hsinchu Hsien, Taiwan, R. O. C

TEL: 03-5894-433

FAX: 03-5894-523

PRODUCT SPECIFICATION

SPEC. NO.

T-0619-003r



1. Scope

This specification applies Wire Wound Ceramic Chip Inductor HSC0603-Series to be delivered to user.

2. Product Identification

HSC 0603 - 10N □ - T

(1) (2) (3) (4) (5)

- (1) Product name
- (2) Shapes and dimensions
- (3) Inductance
10N : 10 nH
- (4) Tolerance
G=±2% , J=±5% , K=±10%
- (5) Taping Type

3. Shapes and Dimensions

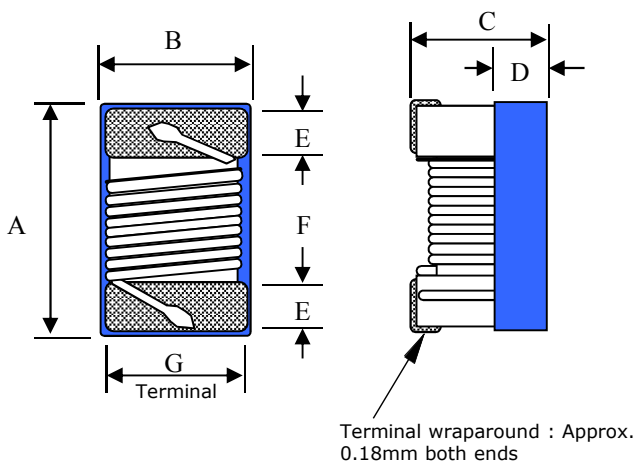

A max.	: 1.8 mm
B max.	: 1.2 mm
C max.	: 1.02 mm
D ref.	: 0.45 mm
E	: 0.33 ± 0.1 mm
F	: 0.89 ± 0.1 mm
G	: 0.90 mm

Equivalent circuit

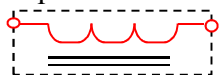

No Polarity

Drawn by	Checked by	Approved by
Cindy Nov. 9. 2017	Zheny Nov. 9. 2017	Sun Nov. 9. 2017

PRODUCT SPECIFICATION

SPEC. NO.

T-0619-003r



4. Electrical Characteristics

Customer Part Number	Our Product Part Number	Inductance (nH)/MHz	Tole.	Q/MHz Min.	900MHz		1.7GHz		SRF (MHz) Min.	Rdc (Ω) Max.	Irms (mA) Max.	Color Coding
					L typ	Q typ	L typ	Q typ				
	HSC0603-1N6□-T	1.6/250	J K	24/250	1.61	72.86	1.61	89.61	12500	0.030	700	Red
	HSC0603-1N8□-T	1.8/250	J K	16/250	1.77	46.55	1.77	59.72	12500	0.045	700	Black
	HSC0603-1N9□-T	1.9/250	J K	13/250	1.85	33.56	1.9	53.33	12500	0.060	700	Red
	HSC0603-2N0□-T	2.0/250	J K	13/250	1.97	44.00	1.96	89.73	12500	0.080	700	Orange
	HSC0603-2N2□-T	2.2/250	J K	13/250	2.14	26.03	2.13	34.11	12500	0.150	700	Yellow
	HSC0603-3N3□-T	3.3/250	J K	30/250	3.42	73.45	3.46	95.36	5900	0.045	700	Blue
	HSC0603-3N6□-T	3.6/250	J K	22/250	3.68	64.2	3.73	82.77	5900	0.063	700	Red
	HSC0603-3N9□-T	3.9/250	G	22/250	3.90	50.11	3.94	67.32	6900	0.080	700	Brown
J												
K												
	HSC0603-4N1□-T	4.1/250	J K	22/250	4.18	66.3	4.38	80.63	6000	0.063	700	Red
	HSC0603-4N3□-T	4.3/250	J K	22/250	4.44	67.5	4.59	81.57	5900	0.063	700	Orange
	HSC0603-4N7□-T	4.7/250	J K	20/250	4.65	58.79	4.75	75.36	5800	0.085	700	Violet
	HSC0603-5N1□-T	5.1/250	J K	20/250	5.07	54.5	5.21	70.06	5700	0.115	700	Green
	HSC0603-5N6□-T	5.6/250	J K	20/250	5.48	43.67	5.66	55.16	5800	0.160	700	Black
	HSC0603-6N0□-T	6.0/250	J	20/250	6.08	64	6.4	108	5700	0.115	700	Brown
			K									
	HSC0603-6N2□-T	6.2/250	G	26/250	6.35	65.72	6.69	85.36	5700	0.115	700	Gray
			J									
			K									
	HSC0603-6N3□-T	6.3/250	J K	26/250	6.54	68.68	6.71	88.51	5700	0.115	700	White
	HSC0603-6N8□-T	6.8/250	G	27/250	6.89	62.87	7.08	82.33	5800	0.125	700	Red
			J									
			K									
	HSC0603-7N5□-T	7.5/250	G	28/250	7.57	65.18	7.84	85.57	4800	0.115	700	Brown
			J									
			K									

PRODUCT SPECIFICATION

SPEC. NO.

T-0619-003r



4. Electrical Characteristics

Customer Part Number	Our Product Part Number	Inductance (nH)/MHz	Tol.	Q/MHz Min.	900MHz		1.7GHz		SRF (MHz) Min.	Rdc (Ω) Max.	Irms (mA) Max.	Color Coding
					L typ	Q typ	L typ	Q typ				
	HSC0603-8N2□-T	8.2/250	J	30/250	8.13	65.01	8.47	82.23	4700	0.125	700	Orange
			K									
	HSC0603-8N7□-T	8.7/250	G	28/250	8.76	63.94	9.22	76.37	4600	0.109	700	Yellow
			J									
			K									
	HSC0603-9N1□-T	9.1/250	J	28/250	9.208	62.29	9.77	75.88	4600	0.120	700	Black
			K									
	HSC0603-9N5□-T	9.5/250	G	28/250	9.79	62.25	10.58	69.16	5400	0.145	700	Blue
			J									
			K									
	HSC0603-10N□-T	10/250	G	31/250	10.36	69.22	10.81	90.90	4800	0.145	700	Orange
			J									
			K									
	HSC0603-11N□-T	11/250	G	30/250	11.22	67.67	11.80	85.69	4000	0.145	700	Gray
			J									
			K									
	HSC0603-12N□-T	12/250	G	35/250	12.37	69.26	13.22	83.39	4000	0.130	700	Yellow
			J									
			K									
	HSC0603-13N□-T	13/250	G	30/250	13.06	71.34	13.27	82.32	4000	0.130	700	Red
			J									
			K									
	HSC0603-15N□-T	15/250	G	35/250	15.22	76.65	16.37	88.93	4000	0.170	700	Green
			J									
			K									
	HSC0603-16N□-T	16/250	G	34/250	16.6	79.11	18.38	79.94	3300	0.170	700	White
			J									
			K									
	HSC0603-18N□-T	18/250	G	35/250	18.44	76.19	20.05	80.07	3100	0.180	700	Blue
			J									
			K									
	HSC0603-19N□-T	19/250	G	35/250	19.71	73.77	23.35	62.78	3000	0.190	700	Brown
			J									
			K									
	HSC0603-20N□-T	20/250	G	38/250	20.5	79.78	23.27	86.77	3000	0.180	700	Red
			J									
			K									

PRODUCT SPECIFICATION

SPEC. NO.

T-0619-003r



4. Electrical Characteristics

Customer Part Number	Our Product Part Number	Inductance (nH)/MHz	Tole.	Q/MHz Min.	900MHz		1.7GHz		SRF (MHz) Min.	Rdc (Ω) Max.	Irms (mA) Max.	Color Coding
					L typ	Q typ	L typ	Q typ				
	HSC0603-22N□-T	22/250	G	38/250	22.66	78.78	25.67	83.99	3000	0.190	700	Violet
			J									
			K									
	HSC0603-23N□-T	23/250	G	38/250	24.19	70.88	28.48	72.86	2850	0.205	700	Orange
			J									
			K									
	HSC0603-24N□-T	24/250	G	36/250	25.74	70.93	31.01	63.21	2650	0.205	700	Black
			J									
			K									
	HSC0603-25N□-T	25/250	G	38/250	25.93	84.76	29.73	89.52	2800	0.210	600	Yellow
			J									
			K									
	HSC0603-27N□-T	27/250	G	40/250	29.03	59.83	37.43	46.06	2800	0.220	600	Gray
			J									
			K	50/500								
	HSC0603-30N□-T	30/250	G	37/250	32.91	68.96	41.66	59.67	2250	0.220	600	Brown
			J									
			K									
	HSC0603-33N□-T	33/250	G	40/250	35.72	61.57	47.39	50.44	2300	0.220	600	White
			J									
			K									
	HSC0603-36N□-T	36/250	G	37/250	39.45	64.02	50.92	59.84	2080	0.250	600	Red
			J									
			K									
	HSC0603-39N□-T	39/250	G	40/250	42.71	61.22	58.42	47.55	2200	0.260	600	Black
			J									
			K									
	HSC0603-43N□-T	43/250	G	38/250	47.21	62.53	64.17	53.05	2000	0.280	600	Orange
			J									
			K									
	HSC0603-47N□-T	47/200	G	38/200	51.82	52.98	77.03	39.17	2000	0.280	600	Brown
			J									
			K									
	HSC0603-51N□-T	51/200	G	38/250	59.27	50.95	103.8	23.61	2130	0.300	600	Violet
			J									
			K									

PRODUCT SPECIFICATION

SPEC. NO.

T-0619-003r



4. Electrical Characteristics

Customer Part Number	Our Product Part Number	Inductance (nH)/MHz	Tole.	Q/MHz Min.	900MHz		1.7GHz		SRF (MHz) Min.	Rdc (Ω) Max.	Irms (mA) Max.	Color Coding
					L typ	Q typ	L typ	Q typ				
	HSC0603-56N□-T	56/200	G	38/200	64.38	51.47	108.1	28.82	1900	0.310	600	Red
			J									
			K									
	HSC0603-62N□-T	62/200	G	37/200	73.3	42.68	156.5	16.15	1800	0.330	600	Gray
			J									
			K									
	HSC0603-68N□-T	68/200	G	37/200	80.23	44.33	174.0	18.31	1700	0.340	600	Orange
			J									
			K									
	HSC0603-72N□-T	72/150	G	34/150	86.67	41.11	212.9	15.59	1700	0.490	400	Yellow
			J									
			K									
	HSC0603-75N□-T	75/150	G	34/150	—	—	—	—	1700	0.430	1000	Blue
			J									
			K									
	HSC0603-79N□-T	79/150	G	34/150	87.02	44.18	—	—	1700	0.500	400	White
			J									
			K									
	HSC0603-82N□-T	82/150	G	34/150	101.2	37.88	300.6	11.78	1700	0.540	400	Green
			J									
			K									
	HSC0603-85N□-T	85/150	G	34/150	92.4	98	—	—	1600	0.550	400	Blue
			J									
			K									
	HSC0603-91N□-T	91/150	G	34/150	111.8	49.36	—	—	1500	0.560	400	Brown
			J									
			K									
	HSC0603-R10□-T	100/150	G	34/150	126.9	36.13	—	—	1400	0.580	400	Blue
			J									
			K									
	HSC0603-R11□-T	110/150	G	32/150	146.8	34.58	—	—	1350	0.610	300	Violet
			J									
			K									
	HSC0603-R12□-T	120/150	G	32/150	166.8	28.57	—	—	1300	0.650	300	Gray
			J									
			K									

PRODUCT SPECIFICATION

SPEC. NO.

T-0619-003r



4. Electrical Characteristics

Customer Part Number	Our Product Part Number	Inductance (nH)/MHz	Tol.	Q/MHz Min.	900MHz		1.7GHz		SRF (MHz) Min.	Rdc (Ω) Max.	Irms (mA) Max.	Color Coding
					L typ	Q typ	L typ	Q typ				
	HSC0603-R13□-T	130/150	G	32/150	180.1	36.93	—	—	1200	0.750	280	Orange
			J									
			K									
	HSC0603-R14□-T	140/150	G	30/150	—	—	—	—	1000	0.900	280	Yellow
			J									
			K									
	HSC0603-R15□-T	150/150	G	28/150	234.9	21.92	—	—	990	0.920	280	White
			J									
			K									
	HSC0603-R16□-T	160/150	G	28/150	247.5	13.58	—	—	990	1.050	260	Red
			J									
			K									
	HSC0603-R17□-T	170/100	G	25/100	228.4	34.96	—	—	990	1.150	240	Yellow
			J									
			K									
	HSC0603-R18□-T	180/100	G	25/100	289.1	19.93	—	—	990	1.250	240	Black
			J									
			K									
	HSC0603-R19□-T	190/100	G	25/100	279.1	30.83	—	—	990	1.350	200	Green
			J									
			K									
	HSC0603-R20□-T	200/100	G	25/100	—	—	—	—	990	1.500	200	Orange
			J									
			K									
	HSC0603-R22□-T	220/100	G	25/100	—	—	—	—	900	1.600	250	Brown
			J									
			K									
	HSC0603-R24□-T	240/100	G	25/100	—	—	—	—	900	1.900	200	Violet
			J									
			K									
	HSC0603-R25□-T	250/100	G	25/100	—	—	—	—	900	2.340	250	Green
			J									
			K									
	HSC0603-R27□-T	270/100	G	24/100	—	—	—	—	900	2.000	170	Red
			J									
			K									
	HSC0603-R30□-T	300/100	G	25/100	—	—	—	—	900	2.700	150	Green
			J									
			K									
	HSC0603-R33□-T	330/100	G	25/100	—	—	—	—	900	2.750	100	Blue
			J									
			K									

PRODUCT SPECIFICATION

SPEC. NO.

T-0619-003r



4. Electrical Characteristics

Customer Part Number	Our Product Part Number	Inductance (nH)/MHz	Tole.	Q/MHz Min.	900MHz		1.7GHz		SRF (MHz) Min.	Rdc (Ω) Max.	Irms (mA) Max.	Color Coding
					L typ	Q typ	L typ	Q typ				
	HSC0603-R34□-T	340/100	G	25/100	-	-	-	-	900	2.900	100	Gray
			J									
			K									
	HSC0603-R36□-T	360/100	G	25/100	-	-	-	-	900	3.070	100	Red
			J									
			K									
	HSC0603-R37□-T	370/100	G	25/100	-	-	-	-	900	3.100	100	Orange
			J									
			K									
	HSC0603-R39□-T	390/100	G	25/100	-	-	-	-	900	3.150	100	Yellow
			J									
			K									
	HSC0603-R47□-T	470/100	G	25/100	-	-	-	-	750	4.000	80	Green
			J									
			K									

1. When ordering, please specify tolerance and packaging codes. Ex: HSC0603-R39J-T

1st Code

Tolerance : G = ±2% , J = ±5% , K = ±10%

Packaging : Clear tape and reel { standard }.

2. L , Q 、 SRF : Agilent/HP E4991A+ Agilent/HP16197A

(The electrical specification test by the smallest gap position) or HP16193A

3. Rdc : Chroma Milliohmmeter 16502, or equivalent.

4. Irms for a 15°C rise above 25°C ambient.

5. Operating temperature range from -40°C to 125°C.

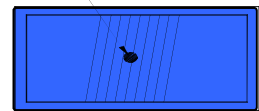

COLOR CODING

PRODUCT SPECIFICATION

SPEC. NO.

T-0619-003r

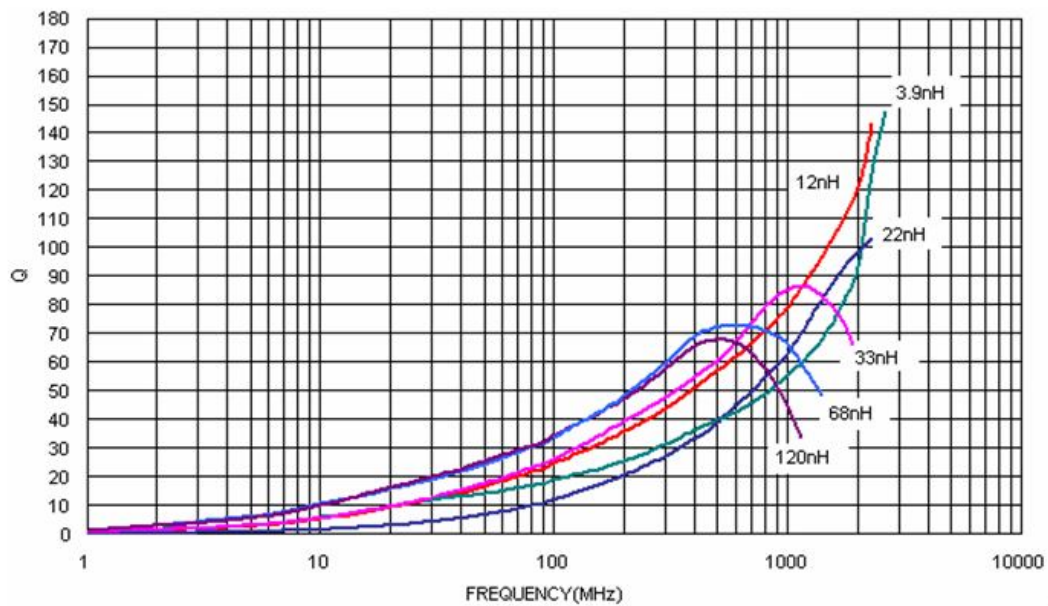
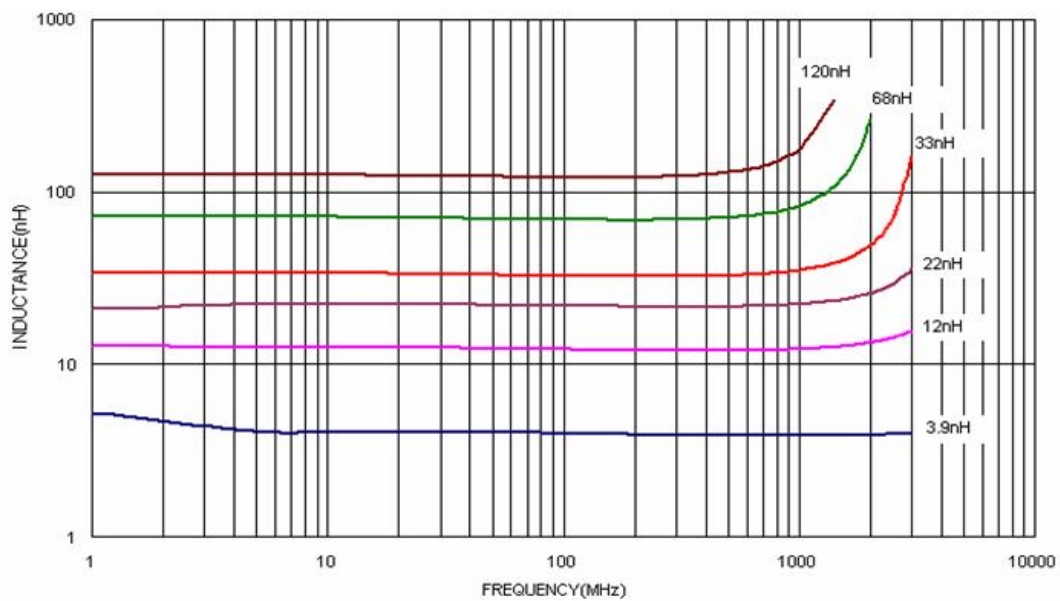

5. Material list

Item	Material
Core	Al ₂ O ₃ 96%
Wire	Copper wire
Epoxy	UV Epoxy

PRODUCT SPECIFICATION

SPEC. NO.

T-0619-003r

**6. Reliability Test**

Item	Specifications	Test conditions
Solderability	The metalized area must have 90% minimum solder coverage.	Dip pads in flux and dip in solder pot(96.5 Sn/3.5 Ag solder) at 255°C ±5°C.
Resistance to soldering heat	There must be no case deformation or change in dimensions. Inductance must not change more than the stated tolerance.	Inductors shall be reflowed onto a PC board using 96.5 Sn/3.5 Ag solder paste. Solder process shall be at a maximum temperature of 260°C. For 96.5 Sn/3.5 Ag solder paste:>217°C for 90 seconds
Vibration	There must be no case deformation or change in dimensions. Inductance must not change more than the stated tolerance.	Solder specimen inductor on the test printed circuit board. Apply vibrations in each of the x,y and z directions for 2 hours for a total of 6 hours. Frequency : 10~50 Hz Amplitude : 1.5mm
High temperature resistance	There must be no case deformation or change in dimensions. Inductance must not change more than the stated tolerance.	Inductors shall be subjected to temperature 125 ±2°C for 500±12 hours. Measure the test items after leaving the inductors at room temperature and humidity for 2 hours.
Component adhesion (push test)	Inductors shall be subjected to 0.9Kg	Inductors shall be reflow soldered (255°C ±5°C for 10 seconds) to a tinned copper substrate. A force gauge shall be applied to the side of the component. The device must withstand the stated force without a failure of the termination.

PRODUCT SPECIFICATION

SPEC. NO.

T-0619-003r

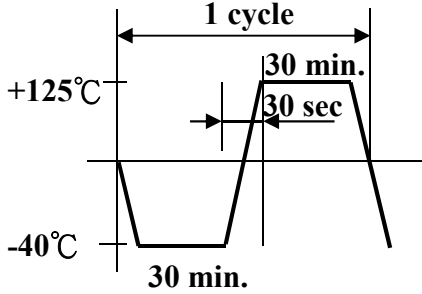

Item	Specifications	Test conditions
Static Humidity	Inductors must not have a shorted or openwinding.	Inductors shall be subjected to temperature $85 \pm 2^{\circ}\text{C}$ and 90 to 95%RH. for ten 24 hours. Measure the test items after leaving the inductors at room temperature and humidity for 2 hours.
Low temperature resistance	There must be no case deformation or change in dimensions. Inductance must not change more than the stated tolerance.	Inductors shall be subjected to temperature $-40 \pm 2^{\circ}\text{C}$ for 500 ± 12 hours. Measure the test items after leaving the inductors at room temperature and humidity for 1 to 2 hours.
Resistance to solvent	There must be no case deformation, change in dimensions, or obliteration of marking.	Inductors must withstand 6 minutes of alcohol or water.
Thermal shock	There must be no case deformation or change in dimensions. Inductance must not change more than the stated tolerance.	<p>Inductors shall be subjected to 10 cycles to the following temperature cycle:</p>  <p>Measure the test items after leaving the inductors at room temperature and humidity for 2 hours.</p>



PRODUCT SPECIFICATION

SPEC. NO.

T-0619-003r

7. Packaging

The packaging must be done not to receive any damage during transporting and storing.

7-1 Tape dimensions

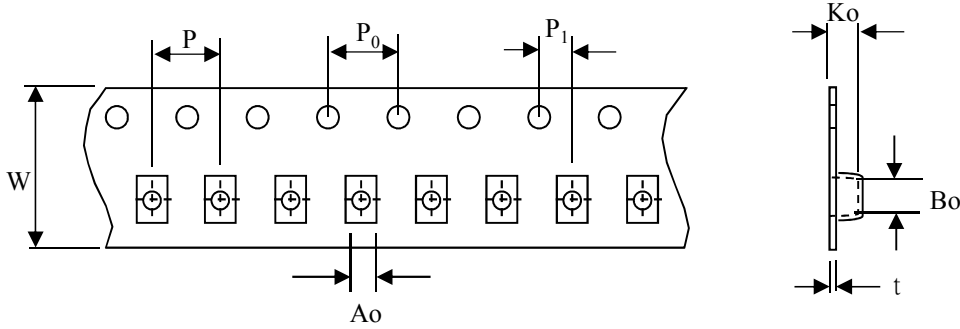

(Dimensions in mm; Tolerance : ±0.1)

Symbol	W	P	P ₀	P ₁	Ao	Bo	Ko	t
Dimension	8	4	4	2	1.2	1.9	1	0.22

7-2 Reel dimensions

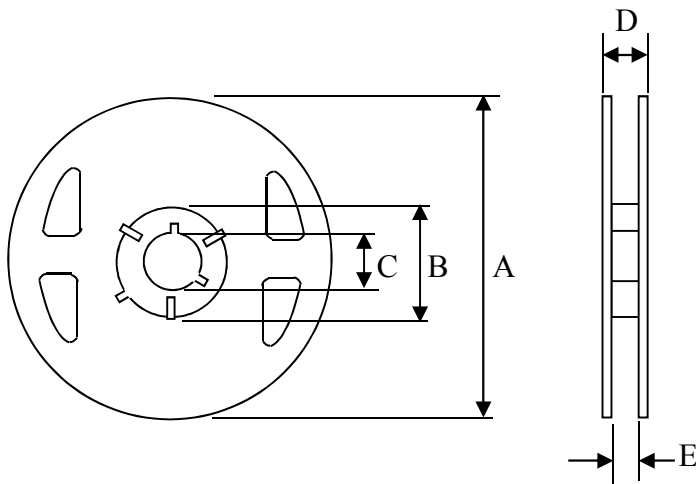

(Dimensions in mm)

Symbol	T
A	180
B	60
C	13
D	14.4
E	8.4

7-3 Tapping figure

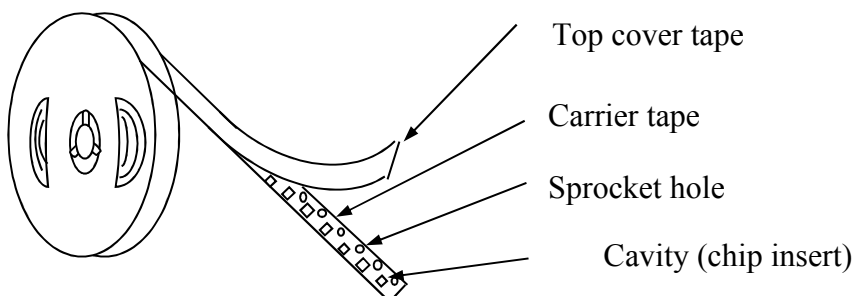

PRODUCT SPECIFICATION

SPEC. NO.

T-0619-003r



7-4 Packaging Form

There shall not continuation more than two vacancies of the product.

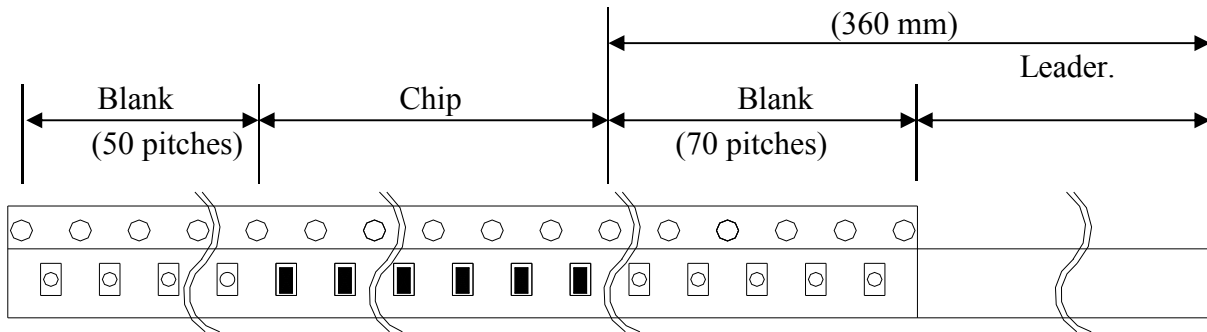

7-5 Cover Tape Peel Strength

The force for tearing off cover tape is 0.1~0.6(N) in the arrow direction at the following conditions:

Temperature : 5 ~ 35°C

Humidity : 45 ~ 85%

Atmospheric pressure : 860 ~ 1060 hpa

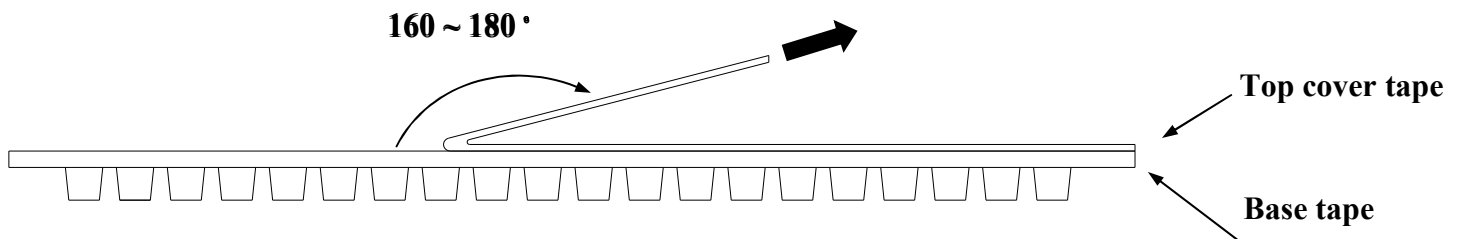

7-6 Packing Quantity

φ180 mm reel type : 4,000 pcs./reel

PRODUCT SPECIFICATION

SPEC. NO.

T-0619-003r



8. Recommended Soldering Conditions

(Please use this product by reflow soldering)

8-1 Recommended Footprint

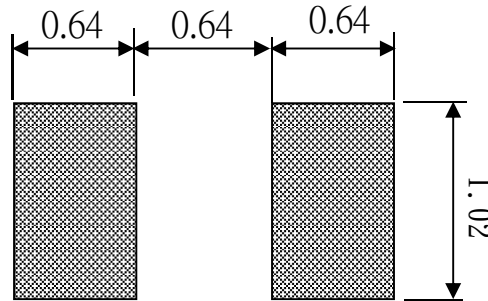

Unit: mm

8-2 Recommended Reflow Pattern

Reflow : until two times

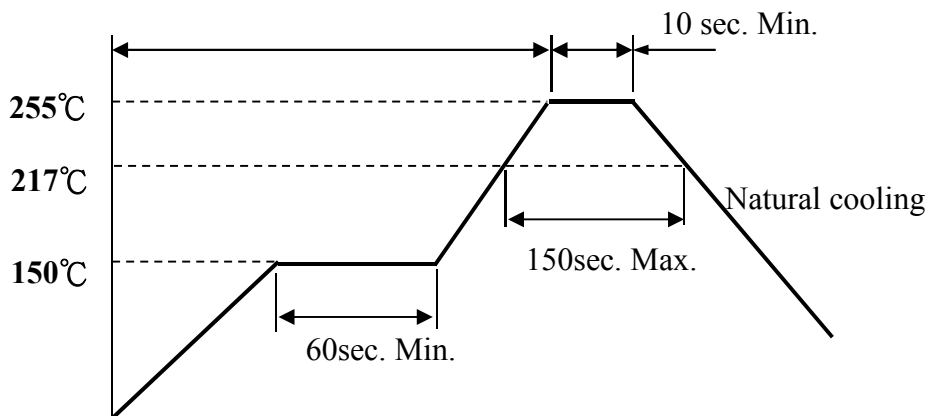

8-3 Iron Soldering

Use a solder iron of less than 30W when soldering, do not allow the soldering iron to directly touch the Ceramic body outside of terminal electrode.

5 seconds max. at 260°C.

9. Attention in Case of Using

In case of using product, please avoid following matters:

Splashing water or salt water

Dew condenses

Toxic gas (Hydrogen sulfide, Sulfurous acid, Chlorine, Ammonia)

Vibrations or shocks which exceed the specified condition

Please be careful for the stress to this product by board flexure or something after the mounting.

10. Others

10-1 Operating temperature range : Ceramic Series : -40~+125°C

10-2 Storage condition : Temperature 20°~25°C, Relative Humidity 40%~60%

10-3 Recommended wire wound inductors should be used within 6 months from the time of delivery.

X-ON Electronics

Largest Supplier of Electrical and Electronic Components

Click to view similar products for [Fixed Inductors](#) category:

Click to view products by [EMTEK](#) manufacturer:

Other Similar products are found below :

[CR32NP-100KC](#) [CR32NP-151KC](#) [CR32NP-180KC](#) [CR32NP-181KC](#) [CR32NP-1R5MC](#) [CR32NP-390KC](#) [CR32NP-3R9MC](#) [CR32NP-680KC](#) [CR32NP-820KC](#) [CR32NP-8R2MC](#) [CR43NP-390KC](#) [CR43NP-560KC](#) [CR43NP-680KC](#) [CR54NP-181KC](#) [CR54NP-470LC](#) [CR54NP-820KC](#) [CR54NP-8R5MC](#) [70F224AI](#) [MGDQ4-00004-P](#) [MHL1ECTTP18NJ](#) [MHQ1005P10NJ](#) [MHQ1005P1N0S](#) [MHQ1005P2N4S](#) [MHQ1005P3N6S](#) [MHQ1005P5N1S](#) [MHQ1005P8N2J](#) [PE-51506NL](#) [PE-53601NL](#) [PE-53602NL](#) [PE-53630NL](#) [PE-53824SNLT](#) [PE-92100NL](#) [PG0434.801NLT](#) [PG0936.113NLT](#) [9220-20](#) [9310-16](#) [PM06-2N7](#) [PM06-39NJ](#) [A01TK](#) [1206CS-471XJ](#) [HC2LP-R47-R](#) [HC2-R47-R](#) [HC3-2R2-R](#) [HCF1305-3R3-R](#) [1206CS-151XG](#) [RCH664NP-140L](#) [RCH664NP-4R7M](#) [RCH8011NP-221L](#) [RCP1317NP-332L](#) [RCP1317NP-391L](#)