

# PRODUCT SPECIFICATION

新弘智

SPEC. NO: T-0619-002L

DATE: Aug. 9, 2018

CUSTOMER'S PRODUCT NAME:

EMTEK PRODUCT NAME:

HSC1008-SERIES

THIS SPECIFICATION IS:

- FULLY ACCEPTED
- DENIED
- ACCEPTED UNDER THE FOLLOWING CONDITIONS



SIGNATURE: \_\_\_\_\_

DATE: \_\_\_\_\_

NAME(PRINT): \_\_\_\_\_

TITLE: \_\_\_\_\_

 **EMTEK CO., LTD.**

本文件內容全部或部份,未經兆欣科技股份有限公司同意不得以任何形式複製或其他用途  
All rights reserved.This document or parts thereof,may not be reproduced by any means or used in any manner without written permission of EMTEK CO.,LTD.

FACTORY:

39, Chingao Rd., (305)Hsinpu,  
Hsinchu Hsien, Taiwan, R. O. C  
TEL: 03-5894-433  
FAX: 03-5894-523

# PRODUCT SPECIFICATION

SPEC. NO.

T-0619-002L



## 1. Scope

This specification applies Ceramic Chip Inductance HSC1008-Series to be delivered to user.

## 2. Product Identification

HSC 1008 - 10N □ - T

(1) (2) (3) (4) (5)

- (1) Product name
- (2) Shapes and dimensions
- (3) Inductance  
10N : 10 nH
- (4) Tolerance  
G=±2% , J=±5% , K=±10%
- (5) Taping Type

## 3. Shapes and Dimensions

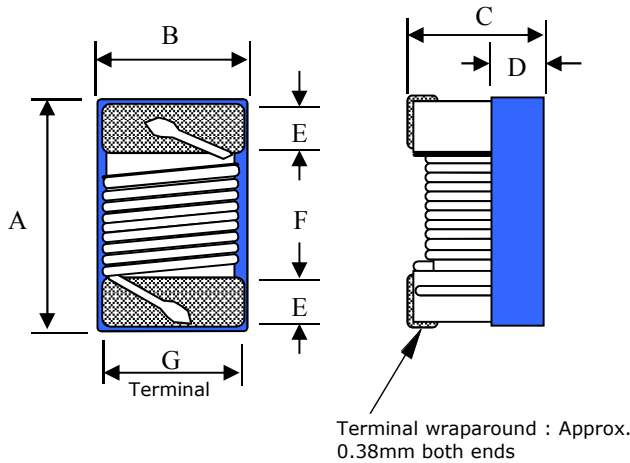

- A max. : 2.90 mm
- B max. : 2.54 mm
- C max. : 2.03 mm
- D ref. : 1.30 mm
- E : 0.45 ± 0.1 mm
- F : 1.60 ± 0.1 mm
- G : 2.0 mm

Equivalent circuit

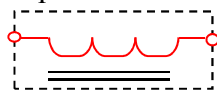

No Polarity

Drawn by	Checked by	Approved by
Cindy Nov.12.2014	Zheng Nov.12.2014	Su Nov.12.2014

# PRODUCT SPECIFICATION

SPEC. NO.

T-0619-002L



## 4. Electrical Characteristics

Customer Part Number	Our Product Part Number	Inductance (nH)/MHz	Inductance Tolerance	Q/MHz Min.	SRF(Min.) (MHz)	RDC ( $\Omega$ )Max.	Irms Max. (mA)	Color Coding		
								1st	2nd	3rd
	HSC1008-4N7□-T	4.7/50	J	28/500	7500	0.15	600	Yellow	Violet	Black
			K							
	HSC1008-10N□-T	10/50	G	50/500	4100	0.08	1000	Brown	Black	Black
			J							
	HSC1008-12N□-T	12/50	K	50/500	3300	0.09	1000	Brown	Red	Black
			G							
	HSC1008-15N□-T	15/50	J	45/500	2500	0.10	1000	Brown	Green	Black
			K							
	HSC1008-18N□-T	18/50	G	50/350	2500	0.11	1000	Brown	Gray	Black
			J							
	HSC1008-22N□-T	22/50	K	55/350	2400	0.12	1000	Red	Red	Black
			G							
	HSC1008-27N□-T	27/50	J	55/350	1600	0.13	1000	Red	Violet	Black
			K							
	HSC1008-33N□-T	33/50	G	60/350	1600	0.14	1000	Orange	Orange	Black
			J							
	HSC1008-39N□-T	39/50	K	60/350	1500	0.15	1000	Orange	White	Black
			G							
	HSC1008-47N□-T	47/50	J	65/350	1500	0.16	1000	Yellow	Violet	Black
			K							
	HSC1008-56N□-T	56/50	G	65/350	1300	0.18	1000	Green	Blue	Black
			J							
	HSC1008-68N□-T	68/50	K	65/350	1300	0.20	1000	Blue	Gray	Black
			G							
	HSC1008-82N□-T	82/50	J	60/350	1000	0.22	1000	Gray	Red	Black
			K							
	HSC1008-R10□-T	100/25	G	60/350	1000	0.56	650	Brown	Black	Brown
			J							
	HSC1008-R12□-T	120/25	K	60/350	950	0.63	650	Brown	Red	Brown
			G							
	HSC1008-R15□-T	150/25	J	45/100	850	0.70	580	Brown	Green	Brown
			K							

**PRODUCT SPECIFICATION**

SPEC. NO.

T-0619-002L

**4. Electrical Characteristics**

Customer Part Number	Our Product Part Number	Inductance (nH)/MHz	Inductance Tolerance	Q/MHz Min.	SRF(Min.) (MHz)	RDC ( $\Omega$ )Max.	Irms Max. (mA)	Color Coding		
								1st	2nd	3rd
	HSC1008-R18□-T	180/25	G	45/100	750	0.77	620	Brown	Gray	Brown
			J							
			K							
	HSC1008-R22□-T	220/25	G	45/100	700	0.84	500	Red	Red	Brown
			J							
			K							
	HSC1008-R27□-T	270/25	G	45/100	600	0.91	500	Red	Violet	Brown
			J							
			K							
	HSC1008-R33□-T	330/25	G	45/100	570	1.05	450	Orange	Orange	Brown
			J							
			K							
	HSC1008-R39□-T	390/25	G	45/100	500	1.12	470	Orange	White	Brown
			J							
			K							
	HSC1008-R47□-T	470/25	G	45/100	450	1.19	470	Yellow	Violet	Brown
			J							
			K							
	HSC1008-R56□-T	560/25	G	45/100	415	1.33	400	Green	Blue	Brown
			J							
			K							
	HSC1008-R62□-T	620/25	G	45/100	375	1.40	300	Blue	Red	Brown
			J							
			K							
	HSC1008-R68□-T	680/25	G	45/100	375	1.47	400	Blue	Gray	Brown
			J							
			K							
	HSC1008-R75□-T	750/25	G	45/100	360	1.54	360	Violet	Green	Brown
			J							
			K							
	HSC1008-R82□-T	820/25	G	45/100	350	1.61	400	Gray	Red	Brown
			J							
			K							
	HSC1008-R91□-T	910/25	G	35/50	320	1.68	380	White	Brown	Brown
			J							
			K							
	HSC1008-1R0□-T	1000/25	G	35/50	290	1.75	370	Brown	Black	Red
			J							
			K							
	HSC1008-1R2□-T	1200/7.9	G	35/50	250	2.00	310	Brown	Red	Red
			J							
			K							

**PRODUCT SPECIFICATION**

SPEC. NO.

T-0619-002L



Customer Part Number	Our Product Part Number	Inductance (nH)/MHz	Inductance Tolerance	Q/MHz Min.	SRF(Min.) (MHz)	RDC (Ω)Max.	Irms Max. (mA)	Color Coding		
								1st	2nd	3rd
	HSC1008-1R5□-T	1500/7.9	G	28/50	200	2.30	330	Brown	Green	Red
			J							
			K							
	HSC1008-1R8□-T	1800/7.9	G	28/50	160	2.60	300	Brown	Gray	Red
			J							
			K							
	HSC1008-2R2□-T	2200/7.9	G	28/50	160	2.80	280	Red	Red	Red
			J							
			K							
	HSC1008-2R7□-T	2700/7.9	G	22/25	135	3.20	290	Red	Violet	Red
			J							
			K							
	HSC1008-3R3□-T	3300/7.9	G	22/25	110	3.40	290	Orange	Orange	Red
			J							
			K							
	HSC1008-3R9□-T	3900/7.9	G	20/25	100	3.60	260	Orange	White	Red
			J							
			K							
	HSC1008-4R7□-T	4700/7.9	G	20/25	90	4.00	260	Yellow	Violet	Red
			J							
			K							
	HSC1008-5R6□-T	5600/7.9	G	18/7.9	40	4.20	240	Green	Blue	Red
			J							
			K							
	HSC1008-6R8□-T	6800/7.9	G	18/7.9	40	4.90	200	Blue	Gray	Red
			J							
			K							
	HSC1008-8R2□-T	8200/7.9	G	18/7.9	25	6.00	170	Gray	Red	Red
			J							
			K							
	HSC1008-100□-T	10000/2.5	G	18/7.9	25	8.00	150	Brown	Black	Orange
			J							
			K							

**PRODUCT SPECIFICATION**

SPEC. NO.

T-0619-002L



1. All specifications are calibrated with Coilcraft 1008CS series
2. When ordering, please specify tolerance and packaging codes. Ex: HSC1008-R12J-T  
Tolerance : G =  $\pm 2\%$  , J =  $\pm 5\%$  , K =  $\pm 10\%$   
Packaging : Clear tape and reel { standard } . \*
3. L , Q 、 SRF : Agilent/HP E4991A+ Agilent/HP16197A  
(The electrical specification test by the smallest gap position) or HP16193A
4. Rdc : DIGITAL MILLIOHM METER Chroma 16502, or equivalent.
5. Irms for a 15°C rise above 25°C ambient.
6. Operating temperature range from -40°C to 125°C.

\* Parts/Reel: 7" 2,000 Tape Width: 8mm

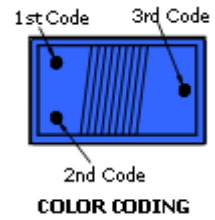

# PRODUCT SPECIFICATION

SPEC. NO.

T-0619-002L

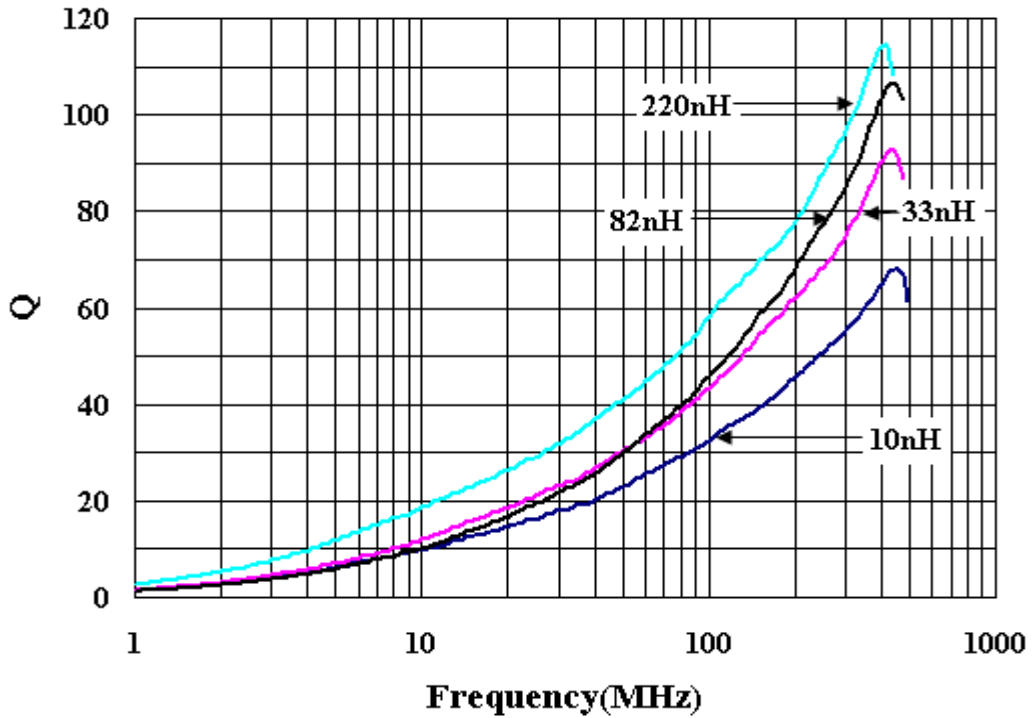
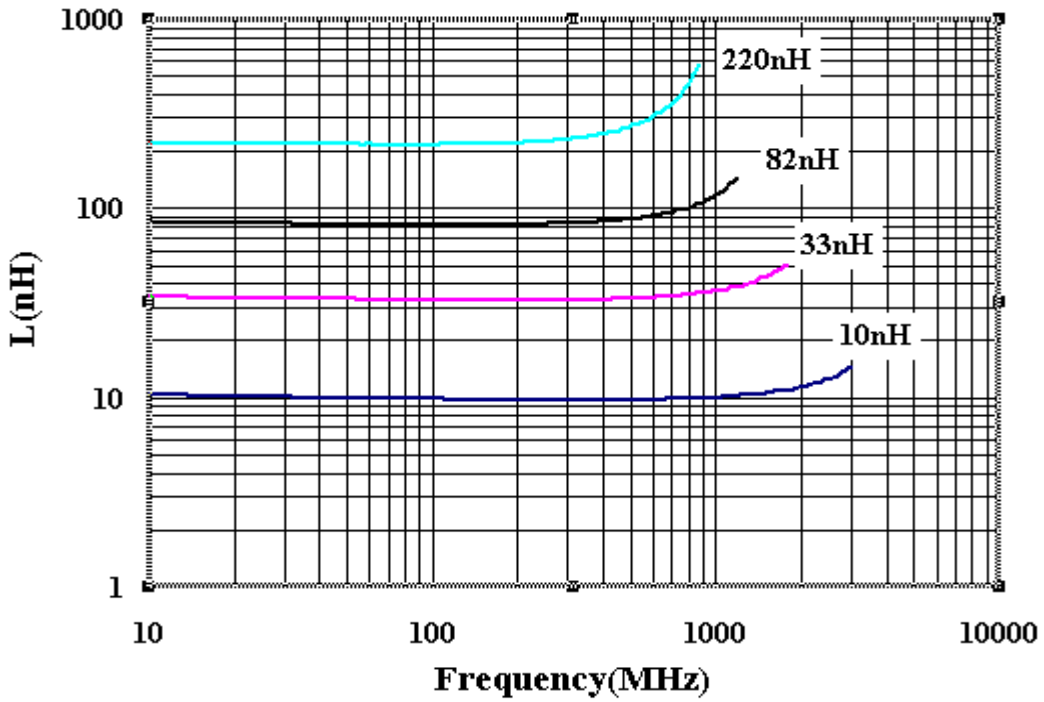

## 5. Material list

Item	Material
Core	Al2O3 96%
Wire	Copper wire
Epoxy	UV Eopxy

**PRODUCT SPECIFICATION**

SPEC. NO.

T-0619-002L

**6. Reliability Test**

Item	Specifications	Test conditions
Solderability	The metalized area must have 90% minimum solder coverage.	Dip pads in flux and dip in solder pot( 96.5 Sn/3.5 Ag solder) at 255°C ±5°C.
Resistance to soldering heat	There must be no case deformation or change in dimensions. Inductance must not change more than the stated tolerance.	Inductors shall be reflowed onto a PC board using 96.5 Sn/3.5 Ag solder paste. Solder process shall be at a maximum temperature of 260°C. For 96.5 Sn/3.5 Ag solder paste:>217°C for 90 seconds
Vibration	There must be no case deformation or change in dimensions. Inductance must not change more than the stated tolerance.	Solder specimen inductor on the test printed circuit board. Apply vibrations in each of the x,y and z directions for 2 hours for a total of 6 hours. Frequency : 10~50 Hz Amplitude : 1.5mm
High temperature resistance	There must be no case deformation or change in dimensions. Inductance must not change more than the stated tolerance.	Inductors shall be subjected to temperature 125±2°C for 500±12 hours. Measure the test items after leaving the inductors at room temperature and humidity for 2 hours.
Static Humidity	Inductors must not have a shorted or openwinding.	Inductors shall be subjected to temperature 85±2°C and 90 to 95%RH. for ten 24-hours. Measure the test items after leaving the inductors at room temperature and humidity for 2 hours.
Component adhesion (push test)	Inductors shall be subjected to 1.8Kg	Inductors shall be reflow soldered (255°C ±5°C for 10 seconds) to a tinned copper substrate. A force gauge shall be applied to the side of the component. The device must withstand the stated force without a failure of the termination.



**PRODUCT SPECIFICATION**

SPEC. NO.

T-0619-002L

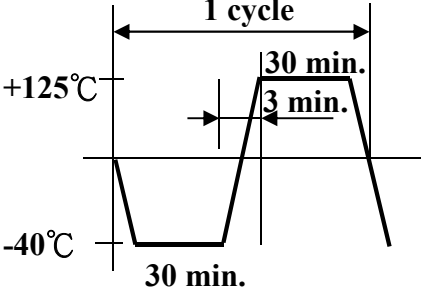

Item	Specifications	Test conditions
Low temperature resistance	There must be no case deformation or change in dimensions. Inductance must not change more than the stated tolerance.	Inductors shall be subjected to temperature $-40\pm 2^{\circ}\text{C}$ for $500\pm 12$ hours. Measure the test items after leaving the inductors at room temperature and humidity for 1 to 2 hours.
Resistance to solvent	There must be no case deformation, change in dimensions, or obliteration of marking.	Inductors must withstand 6 minutes of alcohol or water.
Thermal shock	There must be no case deformation or change in dimensions. Inductance must not change more than the stated tolerance.	Inductors shall be subjected to 10 cycles to the following temperature cycle: <div style="text-align: center;">  </div> <p>Measure the test items after leaving the inductors at room temperature and humidity for 2 hours.</p>

# PRODUCT SPECIFICATION

SPEC. NO.

T-0619-002L



## 7. Packaging

The packaging must be done not to receive any damage during transporting and storing.

### 7-1 Tape dimensions

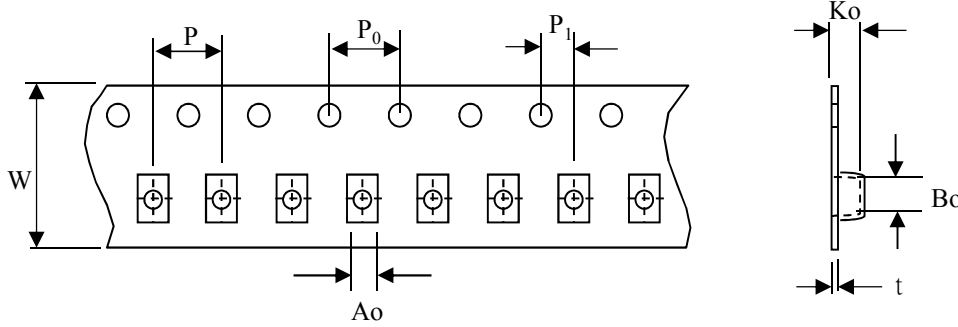

( Dimensions in mm; Tolerance :  $\pm 0.1$  )

Symbol	W	P	P <sub>0</sub>	P <sub>1</sub>	A <sub>0</sub>	B <sub>0</sub>	K <sub>0</sub>	t
Dimension	8	4	4	2	2.5	2.85	2	0.22

### 7-2 Reel dimensions

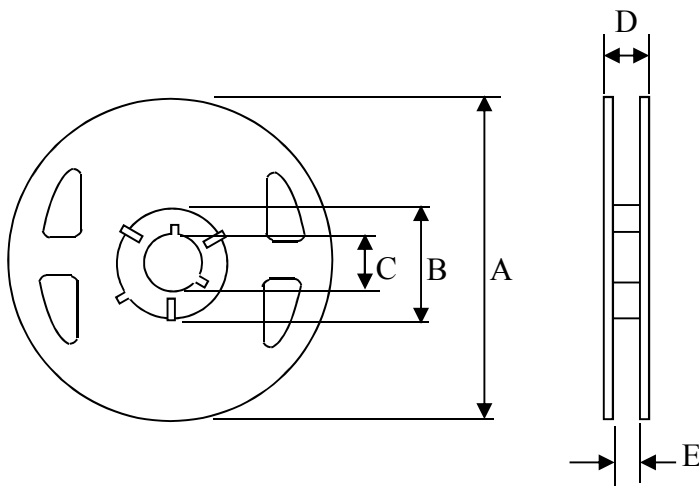

( Dimensions in mm )

Symbol	T
A	180
B	60
C	13
D	14.4
E	8.4

### 7-3 Tapping figure

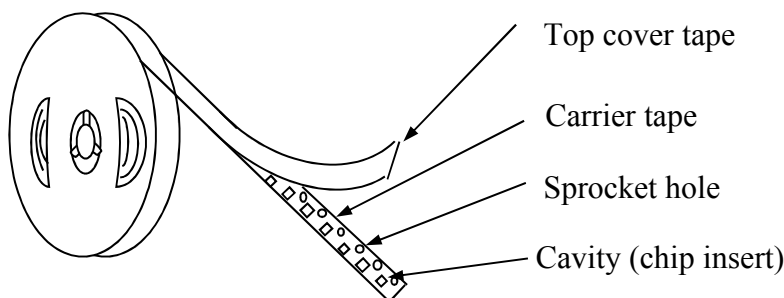

# PRODUCT SPECIFICATION

SPEC. NO.

T-0619-002L



## 7-4 Packaging Form

There shall not continuation more than two vacancies of the product.

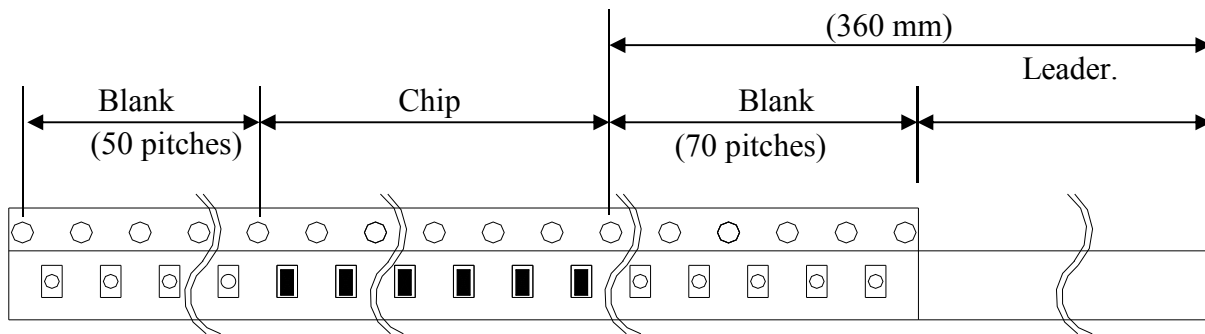

## 7-5 Cover Tape Peel Strength

The force for tearing off cover tape is 0.1~0.6(N) in the arrow direction at the following conditions:

Temperature : 5 ~ 35°C

Humidity : 45 ~ 85%

Atmospheric pressure : 860 ~ 1060 hpa

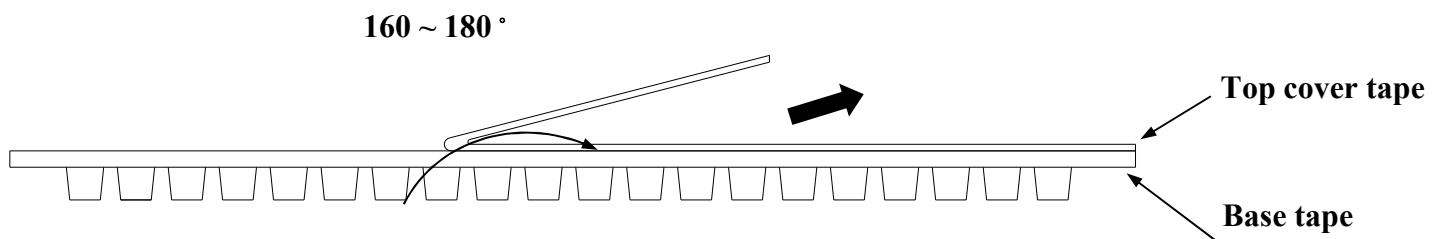

## 7-6 Packing Quantity

φ180 mm reel type : 2,000 pcs./reel

# PRODUCT SPECIFICATION

SPEC. NO.

T-0619-002L



## 8. Recommended Soldering Conditions

(Please use this product by reflow soldering)

### 8-1 Recommended Footprint

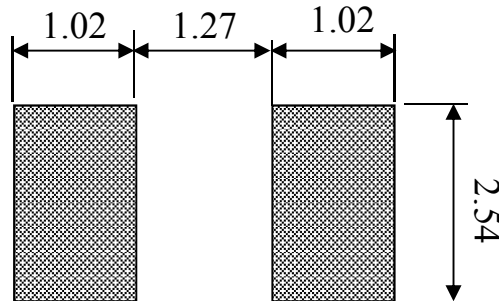

Unit: mm

### 8-2 Recommended Reflow Pattern

Reflow : until two times

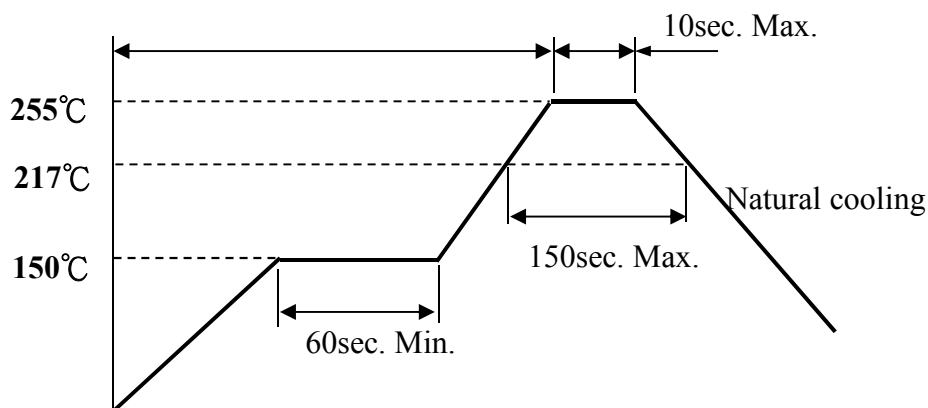

### 8-3 Iron Soldering

Use a solder iron of less than 30W when soldering, do not allow the soldering iron to directly touch the Ceramic body outside of terminal electrode.

5 seconds max. at 260°C.

## 9. Attention in Case of Using

In case of using product, please avoid following matters:

Splashing water or salt water

Dew condenses

Toxic gas (Hydrogen sulfide, Sulfurous acid, Chlorine, Ammonia)

Vibrations or shocks which exceed the specified condition

Please be careful for the stress to this product by board flexure or something after the mounting.

## 10. Others

10-1 Operating temperature range : Ceramic Series : -40~+125°C

10-2 Storage condition : Temperature 20°~25°C, Relative Humidity 40%~60%

10-3 Recommended wire wound inductors should be used within 6 months from the time of delivery.

## X-ON Electronics

Largest Supplier of Electrical and Electronic Components

*Click to view similar products for [Fixed Inductors](#) category:*

*Click to view products by [EMTEK](#) manufacturer:*

Other Similar products are found below :

[CR32NP-100KC](#) [CR32NP-151KC](#) [CR32NP-180KC](#) [CR32NP-181KC](#) [CR32NP-1R5MC](#) [CR32NP-390KC](#) [CR32NP-3R9MC](#) [CR32NP-680KC](#) [CR32NP-820KC](#) [CR32NP-8R2MC](#) [CR43NP-390KC](#) [CR43NP-560KC](#) [CR43NP-680KC](#) [CR54NP-181KC](#) [CR54NP-470LC](#) [CR54NP-820KC](#) [CR54NP-8R5MC](#) [70F224AI](#) [MGDQ4-00004-P](#) [MHL1ECTTP18NJ](#) [MHQ1005P10NJ](#) [MHQ1005P1N0S](#) [MHQ1005P2N4S](#) [MHQ1005P3N6S](#) [MHQ1005P5N1S](#) [MHQ1005P8N2J](#) [PE-51506NL](#) [PE-53601NL](#) [PE-53602NL](#) [PE-53630NL](#) [PE-53824SNLT](#) [PE-92100NL](#) [PG0434.801NLT](#) [PG0936.113NLT](#) [9220-20](#) [9310-16](#) [PM06-2N7](#) [PM06-39NJ](#) [A01TK](#) [1206CS-471XJ](#) [HC2LP-R47-R](#) [HC2-R47-R](#) [HC3-2R2-R](#) [HCF1305-3R3-R](#) [1206CS-151XG](#) [RCH664NP-140L](#) [RCH664NP-4R7M](#) [RCH8011NP-221L](#) [RCP1317NP-332L](#) [RCP1317NP-391L](#)