

PRODUCT SPECIFICATION

SPEC. NO: T-0622-003g

DATE: Aug. 21, 2018

CUSTOMER'S PRODUCT NAME:

EMTEK PRODUCT NAME:

LCF0603-Series

THIS SPECIFICATION IS:

- FULLY ACCEPTED
- DENIED
- ACCEPTED UNDER THE FOLLOWING CONDITIONS



SIGNATURE: _____

DATE: _____

NAME(PRINT): _____

TITLE: _____

 **EMTEK CO., LTD.**

本文件內容全部或部份,未經兆欣科技股份有限公司同意不得以任何形式複製或其他用途
All rights reserved.This document or parts thereof,may not be reproduced by any means or used in any manner without written permission of EMTEK CO.,LTD.

FACTORY:

39, Chingao Rd., (305)Hsinpu,
Hsinchu Hsien, Taiwan, R. O. C

TEL: 03-5894-433

FAX: 03-5894-523

PRODUCT SPECIFICATION

SPEC. NO.

T-0622-003g



1. Scope

This specification applies Ferrite Chip Inductance LCF0603-Series to be delivered to user.

2. Product Identification

LCF 0603 - R82 \square - T

(1) (2) (3) (4) (5)

(1) Product name

(2) Shapes and dimensions

(3) Inductance

R82 : 0.82 μ H

(4) Tolerance

J=±5% , K=±10%

(5) Taping Type

3. Shapes and Dimensions

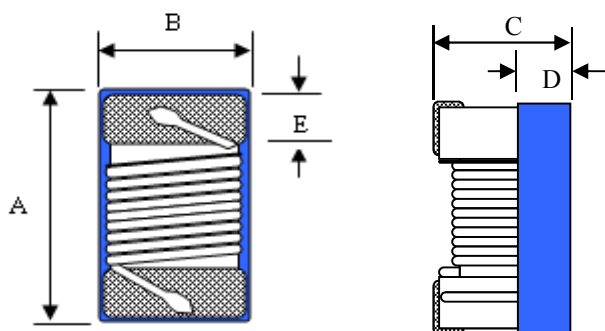

A max. : 1.80 mm
 B max. : 1.20 mm
 C max. : 1.10 mm
 D ref. : 0.45 mm
 E : 0.33 ± 0.1 mm

Equivalent circuit

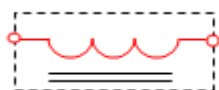

No Polarity

Drawn by	Checked by	Approved by
Gindy Jul. 7. 2016	Zheng Jul. 7. 2016	Su Jul. 7. 2016

PRODUCT SPECIFICATION

SPEC. NO.

T-0622-003g



4. Electrical Characteristics

Customer Part Number	Our Product Part Number	Inductance (uH)/MHz	Inductance Tolerance	Q/MHz Min.	SRF(Min.) (MHz)	Rdc (Ω)Max.	Isat Max. (mA)	Irms Typ. (mA)	Color Coding
	LCF0603-47N□-T	0.047/7.9	J K	12/7.9	2000	0.075	1800	1600	White
	LCF0603-51N□-T	0.051/7.9	J K	12/7.9	1500	0.075	1800	1500	Violet
	LCF0603-56N□-T	0.056/7.9	J K	7/7.9	1500	0.095	2200	1600	Blue
	LCF0603-68N□-T	0.068/7.9	K	10/7.9	1500	0.12	2200	1700	Gray
	LCF0603-72N□-T	0.072/7.9	K	12/7.9	1500	0.12	2200	1600	Brown
	LCF0603-R10□-T	0.10/7.9	J K	12/7.9	1150	0.13	2200	1300	Black
	LCF0603-R12□-T	0.12/7.9	J K	12/7.9	1100	0.15	1900	1300	Orange
	LCF0603-R15□-T	0.15/7.9	J K	15/7.9	1050	0.15	1800	1100	Brown
	LCF0603-R18□-T	0.18/7.9	J K	15/7.9	950	0.15	1800	1100	Green
	LCF0603-R22□-T	0.22/7.9	J K	15/7.9	900	0.30	1300	990	Red
	LCF0603-R24□-T	0.24/7.9	J K	15/7.9	850	0.16	1700	1100	Green
	LCF0603-R27□-T	0.27/7.9	J K	15/7.9	835	0.30	1400	1000	Yellow
	LCF0603-R33□-T	0.33/7.9	J K	15/7.9	725	0.40	1300	1000	Orange
	LCF0603-R36□-T	0.36/7.9	J K	15/7.9	720	0.41	1300	990	Green
	LCF0603-R39□-T	0.39/7.9	J K	15/7.9	680	0.41	1200	990	Blue
	LCF0603-R47□-T	0.47/7.9	J K	15/7.9	640	0.43	1200	860	Black
	LCF0603-R56□-T	0.56/7.9	J K	15/7.9	630	0.44	1200	860	Brown
	LCF0603-R65□-T	0.65/7.9	J K	15/7.9	510	0.52	1000	810	Blue
	LCF0603-R68□-T	0.68/7.9	J K	15/7.9	510	0.52	1000	780	Red
	LCF0603-R78□-T	0.78/7.9	J K	15/7.9	465	0.63	990	780	Orange



PRODUCT SPECIFICATION

SPEC. NO.

T-0622-003g

4. Electrical Characteristics

Customer Part Number	Our Product Part Number	Inductance (uH)/MHz	Inductance Tolerance	Q/MHz Min.	SRF(Min.) (MHz)	Rdc (Ω)Max.	Isat Max. (mA)	Irms Typ. (mA)	Color Coding
	LCF0603-R82□-T	0.82/7.9	J K	15/7.9	460	0.69	990	760	Yellow
	LCF0603-R90□-T	0.90/7.9	J K	15/7.9	350	0.81	950	700	Black
	LCF0603-1R0□-T	1.0/7.9	J K	15/7.9	320	0.81	850	700	Green
	LCF0603-1R2□-T	1.2/7.9	J K	15/7.9	270	0.87	850	590	Blue
	LCF0603-1R5□-T	1.5/7.9	J K	15/7.9	230	0.96	830	570	Violet
	LCF0603-1R8□-T	1.8/7.9	J K	15/7.9	210	1.10	820	540	Gray
	LCF0603-2R2□-T	2.2/7.9	J K	15/7.9	115	1.20	720	540	White
	LCF0603-2R7□-T	2.7/7.9	J K	15/7.9	100	1.38	700	460	Black
	LCF0603-3R0□-T	3.0/7.9	J K	15/7.9	90	1.45	680	430	Black
	LCF0603-3R3□-T	3.3/7.9	J K	15/7.9	84	1.50	640	480	Brown
	LCF0603-3R9□-T	3.9/7.9	J K	15/7.9	75	1.50	630	480	Red
	LCF0603-4R7□-T	4.7/7.9	J K	15/7.9	67	2.10	530	380	Orange
	LCF0603-5R6□-T	5.6/7.9	J K	15/7.9	55	2.37	510	360	Yellow
	LCF0603-6R8□-T	6.8/7.9	J K	15/7.9	48	3.10	490	350	Green
	LCF0603-7R8□-T	7.8/7.9	J K	15/7.9	40	3.35	420	320	Blue
	LCF0603-8R2□-T	8.2/7.9	J K	15/7.9	38	3.50	450	320	Violet
	LCF0603-100□-T	10/7.9	J K	15/7.9	32	4.46	370	280	Gray



PRODUCT SPECIFICATION

SPEC. NO.

T-0622-003g

4. Electrical Characteristics

Customer Part Number	Our Product Part Number	Inductance (uH)/MHz	Inductance Tolerance	Q/MHz Min.	SRF(Min.) (MHz)	Rdc (Ω)Max.	Isat Max. (mA)	Irms Typ. (mA)	Color Coding
	LCF0603-150□-T	15/7.9	J	14/7.9	25	9.50	240	170	White
			K						

1. When ordering, please specify tolerance and packaging codes. Ex: LCF0603-1R0J-T

Tolerance : J = ±5% , K = ±10%

Packaging : Clear tape and reel { standard }.

2. L , Q 、 SRF : Agilent/HP E4991A+ Agilent/HP16197A

(The electrical specification test by the smallest gap position) or HP16193A

3. Rdc : DIGITAL MILLIOHM METER Chroma 16502, or equivalent.

4. Isat for Inductance drop 35% from its value without current.

5. Operating temperature range from -25°C to 105°C.

6. Irms For 40°C rise form 25°C ambient.

1st Code

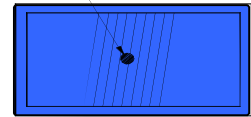

COLOR CODING

PRODUCT SPECIFICATION

SPEC. NO.

T-0622-003g

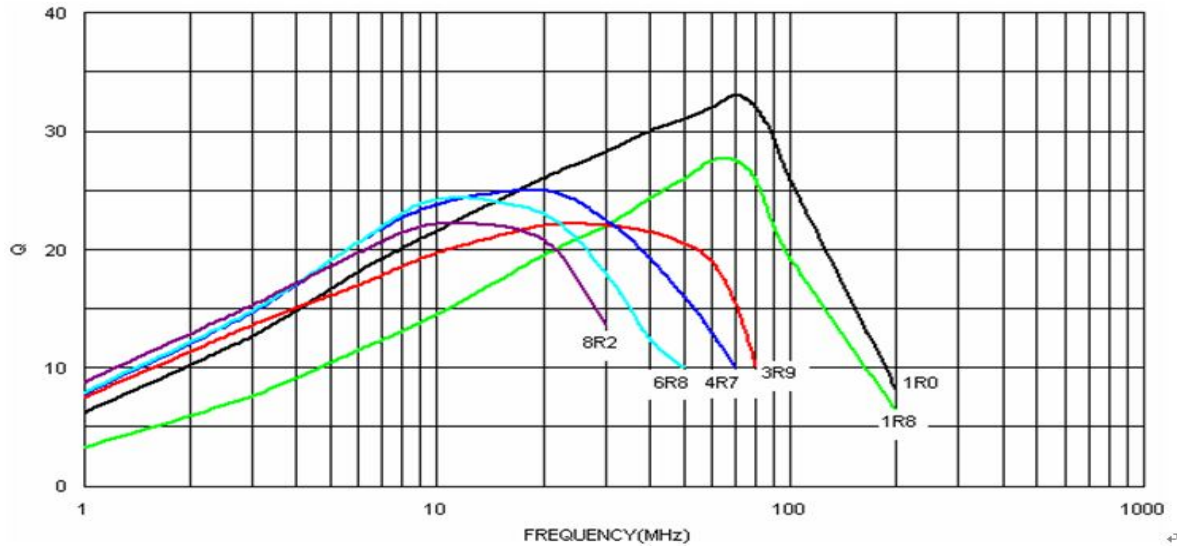
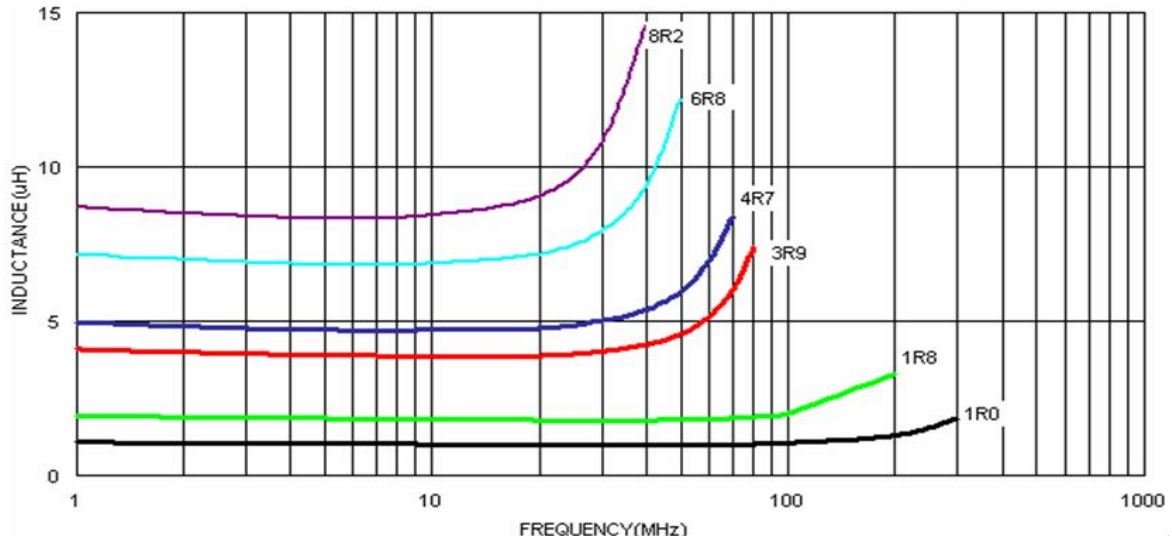

5. Material list

Item	Material
Core	Ferrite core
Wire	Copper wire
Epoxy	UV Epoxy

PRODUCT SPECIFICATION

SPEC. NO.

T-0622-003g



6. Reliability Test

Item	Specifications	Test conditions
Solderability	The metalized area must have 90% minimum solder coverage.	Dip pads in flux and dip in solder pot(96.5 Sn/3.5 Ag solder) at 255°C ±5°C.
Resistance to soldering heat	There must be no case deformation or change in dimensions. Inductance must not change more than the stated tolerance.	Inductors shall be reflowed onto a PC board using 96.5 Sn/3.5 Ag solder paste. Solder process shall be at a maximum temperature of 260°C. For 96.5 Sn/3.5 Ag solder paste:>217°C for 90 seconds
Vibration	There must be no case deformation or change in dimensions. Inductance must not change more than the stated tolerance.	Solder specimen inductor on the test printed circuit board. Apply vibrations in each of the x,y and z directions for 2 hours for a total of 6 hours. Frequency : 10~50 Hz Amplitude : 1.5mm
High temperature resistance	There must be no case deformation or change in dimensions. Inductance must not change more than the stated tolerance.	Inductors shall be subjected to temperature 105±2°C for 500±12 hours. Measure the test items after leaving the inductors at room temperature and humidity for 2 hours.
Static Humidity	Inductors must not have a shorted or openwinding.	Inductors shall be subjected to temperature 85±2°C and 90 to 95%RH. for ten 24-hours. Measure the test items after leaving the inductors at room temperature and humidity for 2 hours.
Component adhesion (push test)	Inductors shall be subjected to 0.45Kg	Inductors shall be reflow soldered (255°C ±5°C for 10 seconds) to a tinned copper substrate. A force gauge shall be applied to the side of the component. The device must withstand the stated force without a failure of the termination.

PRODUCT SPECIFICATION

SPEC. NO.

T-0622-003g

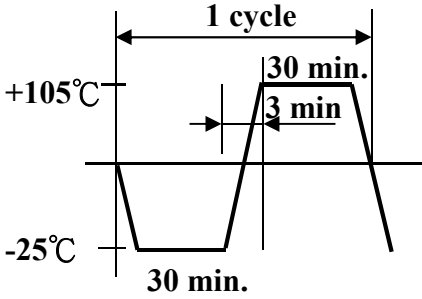

Item	Specifications	Test conditions
Low temperature resistance	There must be no case deformation or change in dimensions. Inductance must not change more than the stated tolerance.	Inductors shall be subjected to temperature $-25\pm 2^{\circ}\text{C}$ for 500 ± 12 hours. Measure the test items after leaving the inductors at room temperature and humidity for 1 to 2 hours.
Resistance to solvent	There must be no case deformation, change in dimensions, or obliteration of marking.	Inductors must withstand 6 minutes of alcohol or water.
Thermal Shock	There must be no case deformation or change in dimensions. Inductance must not change more than the stated tolerance.	Inductors shall be subjected to 10 cycles to the following temperature cycle: <div style="text-align: center;">  <p>The diagram illustrates a temperature cycle between $+105^{\circ}\text{C}$ and -25°C. The cycle consists of a 30-minute dwell at $+105^{\circ}\text{C}$, a 3-minute transition to -25°C, a 30-minute dwell at -25°C, and a 3-minute transition back to $+105^{\circ}\text{C}$. The total duration of one cycle is 1 cycle.</p> </div> Measure the test items after leaving the inductors at room temperature and humidity for 2 hours.



PRODUCT SPECIFICATION

SPEC. NO.

T-0622-003g

7. Packaging

The packaging must be done not to receive any damage during transporting and storing.

7-1 Tape dimensions

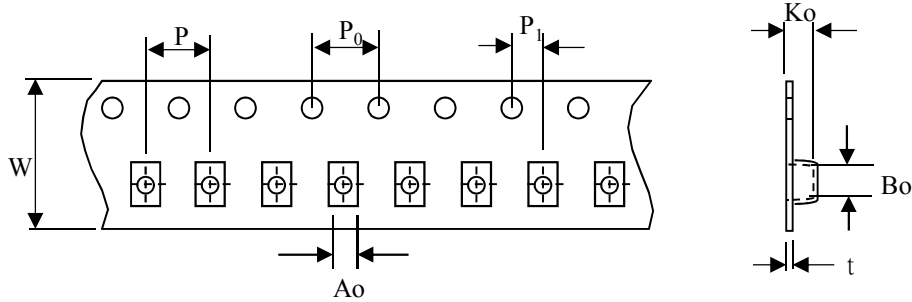

(Dimensions in mm; Tolerance : ±0.1)

Symbol	W	P	P ₀	P ₁	A _o	B _o	K _o	t
Dimension	8	4	4	2	1.25	1.9	1.05	0.22

7-2 Reel dimensions

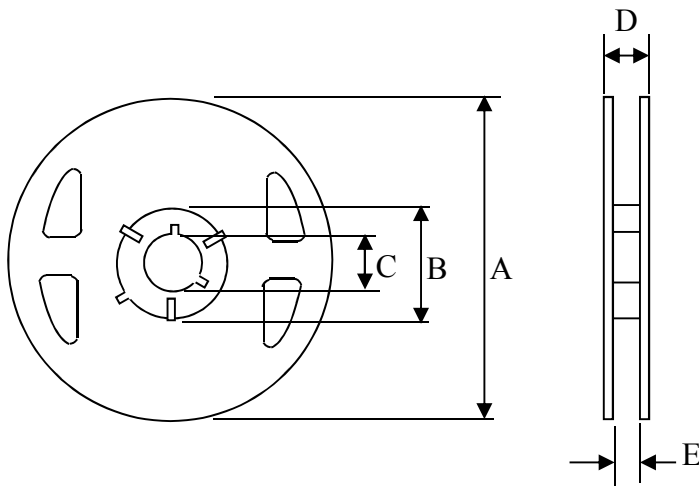

(Dimensions in mm)

Symbol	T
A	180
B	60
C	13
D	14.4
E	8.4

7-3 Tapping figure

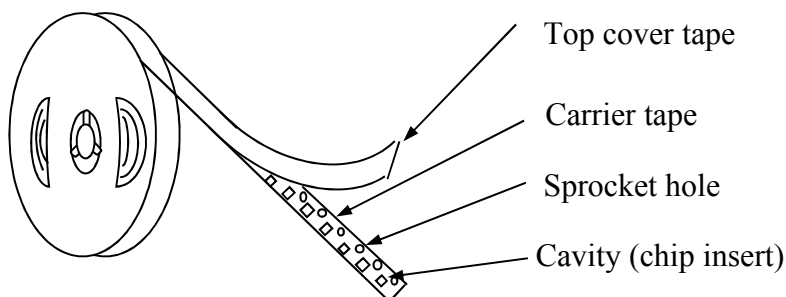

PRODUCT SPECIFICATION

SPEC. NO.

T-0622-003g



7-4 Packaging Form

There shall not continuation more than two vacancies of the product.

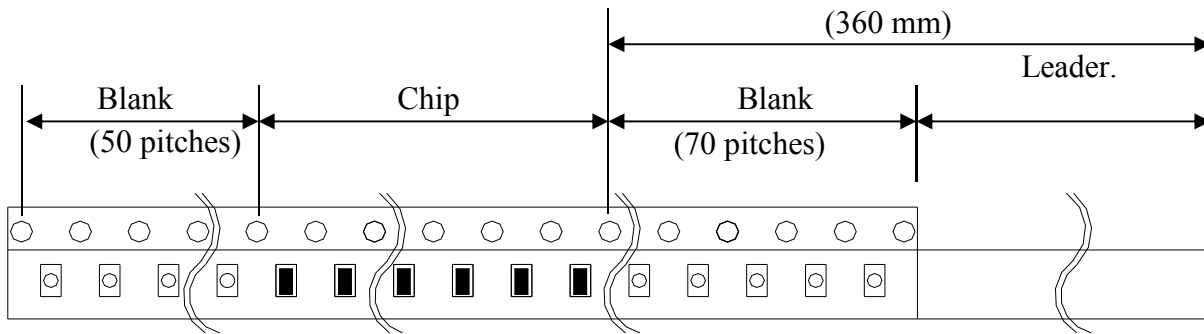

7-5 Cover Tape Peel Strength

The force for tearing off cover tape is 0.1~0.6(N) in the arrow direction at the following conditions:

Temperature : 5 ~ 35°C

Humidity : 45 ~ 85%

Atmospheric pressure : 860 ~ 1060 hpa

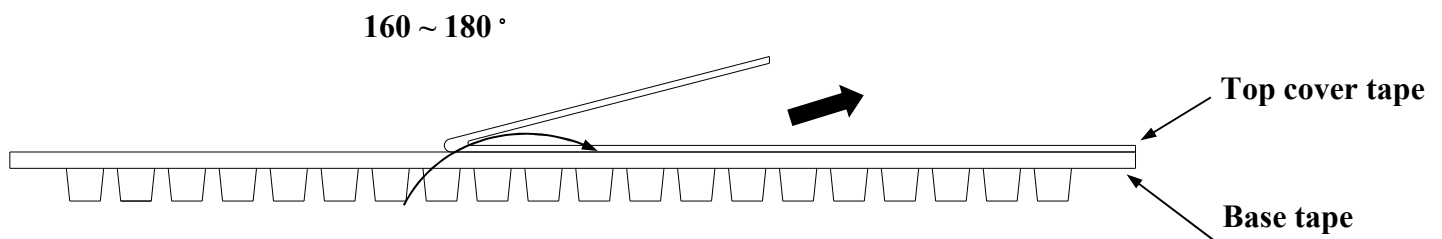

7-6 Packing Quantity

φ180 mm reel type : 4,000 pcs./reel

PRODUCT SPECIFICATION

SPEC. NO.

T-0622-003g



8. Recommended Soldering Conditions

(Please use this product by reflow soldering)

8-1 Recommended Footprint

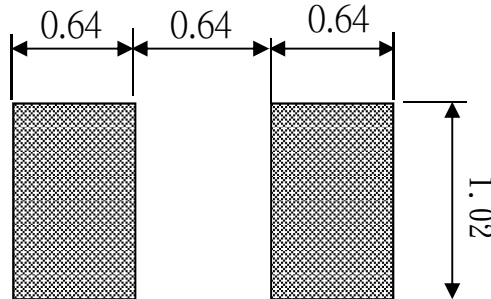

Unit: mm

8-2 Recommended Reflow Pattern

Reflow : until two times

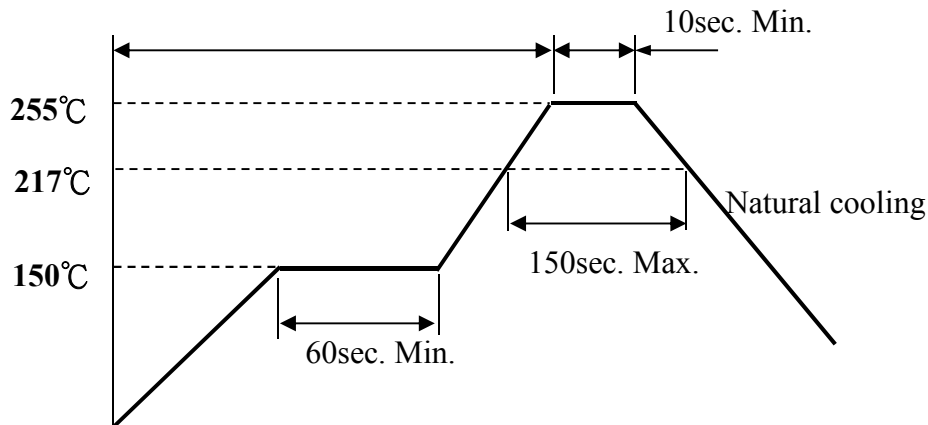

8-3 Iron Soldering

Use a solder iron of less than 30W when soldering, do not allow the soldering iron to directly touch the Ceramic body outside of terminal electrode.

5 seconds max. at 260°C.

9. Attention in Case of Using

In case of using product, please avoid following matters:

Splashing water or salt water

Dew condenses

Toxic gas (Hydrogen sulfide, Sulfurous acid, Chlorine, Ammonia)

Vibrations or shocks which exceed the specified condition

Please be careful for the stress to this product by board flexure or something after the mounting.

10. Others

10-1 Operating temperature range : Ferrite Series : -25~+105°C

10-2 Storage condition : Temperature 20°~25°C, Relative Humidity 40%~60%

10-3 Recommended wire wound inductors should be used within 6 months from the time of delivery.

X-ON Electronics

Largest Supplier of Electrical and Electronic Components

Click to view similar products for [Fixed Inductors](#) category:

Click to view products by [EMTEK](#) manufacturer:

Other Similar products are found below :

[CR32NP-100KC](#) [CR32NP-151KC](#) [CR32NP-180KC](#) [CR32NP-181KC](#) [CR32NP-1R5MC](#) [CR32NP-390KC](#) [CR32NP-3R9MC](#) [CR32NP-680KC](#) [CR32NP-820KC](#) [CR32NP-8R2MC](#) [CR43NP-390KC](#) [CR43NP-560KC](#) [CR43NP-680KC](#) [CR54NP-181KC](#) [CR54NP-470LC](#) [CR54NP-820KC](#) [CR54NP-8R5MC](#) [70F224AI](#) [MGDQ4-00004-P](#) [MHL1ECTTP18NJ](#) [MHQ1005P10NJ](#) [MHQ1005P1N0S](#) [MHQ1005P2N4S](#) [MHQ1005P3N6S](#) [MHQ1005P5N1S](#) [MHQ1005P8N2J](#) [PE-51506NL](#) [PE-53601NL](#) [PE-53602NL](#) [PE-53630NL](#) [PE-53824SNLT](#) [PE-92100NL](#) [PG0434.801NLT](#) [PG0936.113NLT](#) [9220-20](#) [9310-16](#) [PM06-2N7](#) [PM06-39NJ](#) [A01TK](#) [1206CS-471XJ](#) [HC2LP-R47-R](#) [HC2-R47-R](#) [HC3-2R2-R](#) [HCF1305-3R3-R](#) [1206CS-151XG](#) [RCH664NP-140L](#) [RCH664NP-4R7M](#) [RCH8011NP-221L](#) [RCP1317NP-332L](#) [RCP1317NP-391L](#)