

PRODUCT SPECIFICATION

新弘智

SPEC. NO: T-0622-063

DATE: Jul. 26, 2018

CUSTOMER' S PRODUCT NAME:

EMTEK PRODUCT NAME:

LCF1206-Series

THIS SPECIFICATION IS:

- FULLY ACCEPTED
- DENIED
- ACCEPTED UNDER THE FOLLOWING CONDITIONS



SIGNATURE: _____

DATE: _____

NAME(PRINT): _____

TITLE: _____

 **EMTEK CO., LTD.**

本文件內容全部或部份,未經兆欣科技股份有限公司同意不得以任何形式複製或其他用途
All rights reserved.This document or parts thereof,may not be reproduced by any means or used in any manner without written permission of EMTEK CO.,LTD.

FACTORY:

39, Chingao Rd., (305)Hsinpu,
Hsinchu Hsien, Taiwan, R. O. C

TEL: 03-5894-433

FAX: 03-5894-523

PRODUCT SPECIFICATION

SPEC. NO.
T-0622-063



1. Scope

This specification applies Ceramic Chip Inductance LCF1206-Series to be delivered to user.

2. Product Identification

LCF 1206 - 3R3 □ - T
(1) (2) (3) (4) (5)

- (1) Dimension
- (2) Type
- (3) Inductance
3R3 :3300 nH
- (4) Tolerance
J=±5% , K=±10%
- (5) Taping Type

3. Shapes and Dimensions

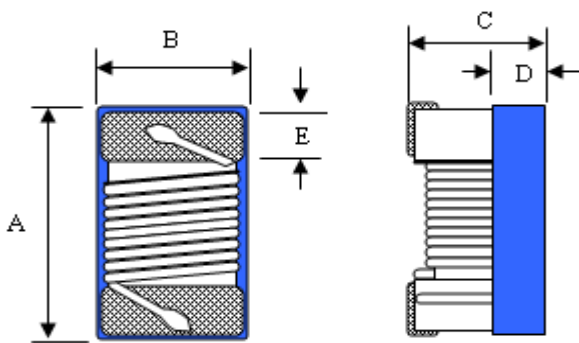

A max. : 3.56 mm
 B max. : 2.16 mm
 C max. : 1.52 mm
 D ref. : 0.51 mm
 E : 0.51±0.1 mm

Equivalent circuit

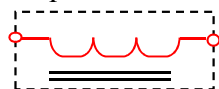

No Polarity

Drawn by	Checked by	Approved by
Gindy Jul. 5. 2017	Henry Jul. 5. 2017	Dragon Jul. 5. 2017

PRODUCT SPECIFICATION

SPEC. NO.

T-0622-063

**4. Electrical Characteristics**

Customer Part Number	Our Product Part Number	Inductance (nH)/MHz	Inductance Tolerance	Q /MHz Min.	SRF (MHz) Min.	Rdc (Ω) Max.	Idc (mA) Min.	Irms (mA) Min.	Color Coding		
									1st	2nd	3rd
	LCF1206-3R3□-T	3300/7.9	J,K	25/7.9	240	1.32	400	450	Orange	Orange	Red

- All specifications are calibrated with Coilcraft 1206 series
- When ordering, please specify tolerance and packaging codes. Ex: LCF1206-3R3J-T
Tolerance :J = ±5% , K=±10%
Packaging : Clear tape and reel { standard } . *
- L , Q , SRF: Agilent E4991A RF Impedance/Material Analyzer+ Agilent 16197A Test Fixtures
(The electrical specification test by the smallest gap position), or equivalent
- Rdc : Chroma 16502 Milliohm meter, or equivalent.
- Irms for a 25°C rise above 25°C ambient.
- Operating temperature range from -40°C to 125°C.
* Parts/Reel: 7" 2,000 Tape Width: 8mm
- Idc for Inductance drop 10% from its value without current.

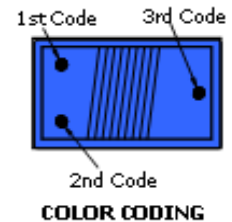

PRODUCT SPECIFICATION

SPEC. NO.

T-0622-063



— LCF-1206-3R3J-T L vs Idc 曲線圖

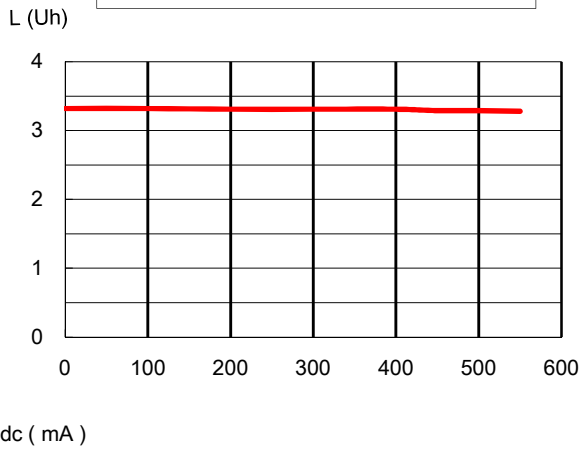

— LCF-1206-3R3J-T Irms vs Idc 曲線圖

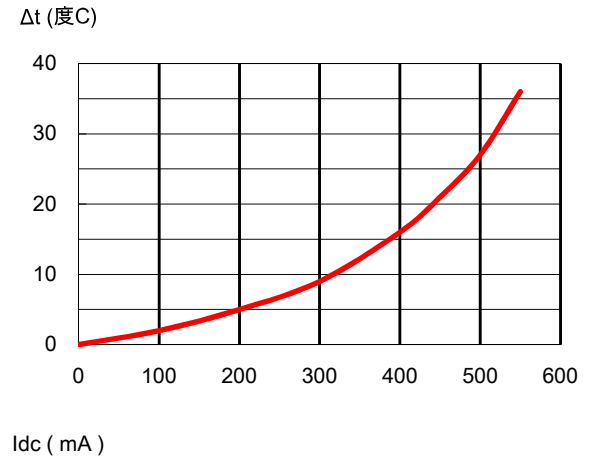

5. Material list

Item	Material
Core	Al ₂ O ₃ 96%
Wire	Copper wire
Epoxy	UV Epoxy

PRODUCT SPECIFICATION

SPEC. NO.

T-0622-063

**6. Reliability Test**

Item	Specifications	Test conditions
Solderability	The metalized area must have 90% minimum solder coverage.	Dip pads in flux and dip in solder pot(96.5 Sn/3.5 Ag solder) at 255°C ±5°C.
Resistance to soldering heat	There must be no case deformation or change in dimensions. Inductance must not change more than the stated tolerance.	Inductors shall be reflowed onto a PC board using 96.5 Sn/3.5 Ag solder paste. Solder process shall be at a maximum temperature of 260°C. For 96.5 Sn/3.5 Ag solder paste:>217°C for 90 seconds
Vibration	There must be no case deformation or change in dimensions. Inductance must not change more than the stated tolerance.	Solder specimen inductor on the test printed circuit board. Apply vibrations in each of the x,y and z directions for 2 hours for a total of 6 hours. Frequency : 10~50 Hz Amplitude : 1.5mm
High temperature resistance	There must be no case deformation or change in dimensions. Inductance must not change more than the stated tolerance.	Inductors shall be subjected to temperature 125±2°C for 50±12 hours. Measure the test items after leaving the inductors at room temperature and humidity for 2 hours.
Static Humidity	Inductors must not have a shorted or openwinding.	Inductors shall be subjected to temperature 85±2°C and 90 to 95%RH. for ten 24-hours. Measure the test items after leaving the inductors at room temperature and humidity for 2 hours.
Component adhesion (push test)	Inductors shall be subjected to 1.0Kg	Inductors shall be reflow soldered (255°C ±5°C for 10 seconds) to a tinned copper substrate. A force gauge shall be applied to the side of the component. The device must withstand the stated force without a failure of the termination.

PRODUCT SPECIFICATION

SPEC. NO.

T-0622-063



Item	Specifications	Test conditions
Low temperature resistance	<p>There must be no case deformation or change in dimensions.</p> <p>Inductance must not change more than the stated tolerance.</p>	<p>Inductors shall be subjected to temperature $-40\pm 2^{\circ}\text{C}$ for 48 ± 12 hours.</p> <p>Measure the test items after leaving the inductors at room temperature and humidity for 1 to 2 hours.</p>
Resistance to solvent	<p>There must be no case deformation, change in dimensions, or obliteration of marking.</p>	<p>Inductors must withstand 6 minutes of alcohol or water.</p>
Thermal shock	<p>There must be no case deformation or change in dimensions.</p> <p>Inductance must not change more than the stated tolerance.</p>	<p>Inductors shall be subjected to 10 cycles to the the following temperature cycle:</p> <div data-bbox="965 1137 1372 1433" style="text-align: center;"> <p>The diagram illustrates a temperature cycle. The vertical axis represents temperature, with markers for $+125^{\circ}\text{C}$ and -40°C. The horizontal axis represents time. The cycle consists of a ramp down from room temperature to -40°C, a dwell at -40°C for 30 minutes, a ramp up to $+125^{\circ}\text{C}$ (labeled as 30 sec), a dwell at $+125^{\circ}\text{C}$ for 30 minutes, and a final ramp down. A double-headed arrow above the cycle indicates the duration of '1 cycle'.</p> </div> <p>Measure the test items after leaving the inductors at room temperature and humidity for 2 hours.</p>

PRODUCT SPECIFICATION

SPEC. NO.

T-0622-063



7. Packaging

The packaging must be done not to receive any damage during transporting and storing.

7-1 Tape dimensions

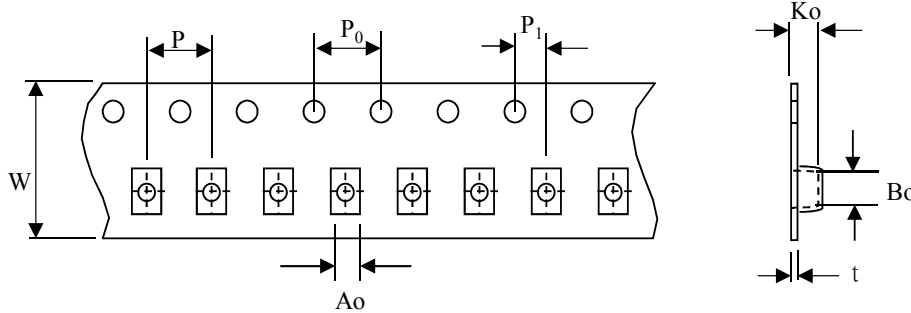

(Dimensions in mm)

Symbol	W	P	P_0	P_1	A_o	B_o	K_o	t
Dimension	8	4	4	2	2.14	3.56	1.5	0.22
Tolerance	± 0.10	± 0.10	± 0.10	± 0.10	± 0.05	± 0.05	± 0.05	± 0.05

7-2 Reel dimensions

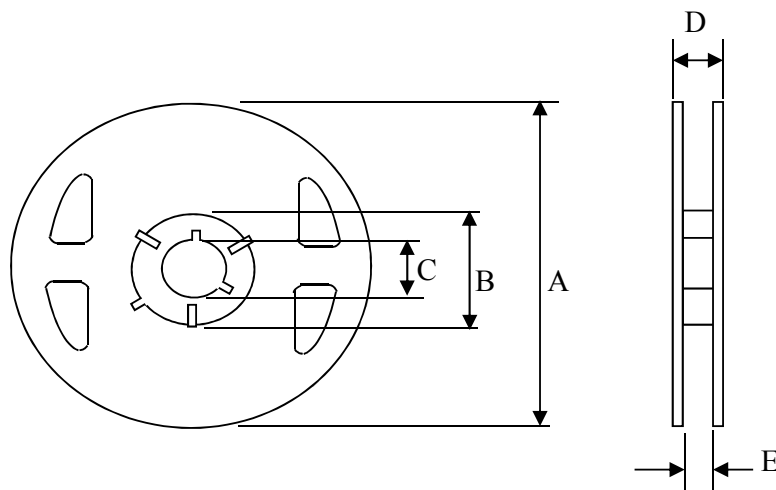

(Dimensions in mm)

Symbol	T
A	180
B	60
C	13
D	14.4
E	8.4

7-3 Tapping figure

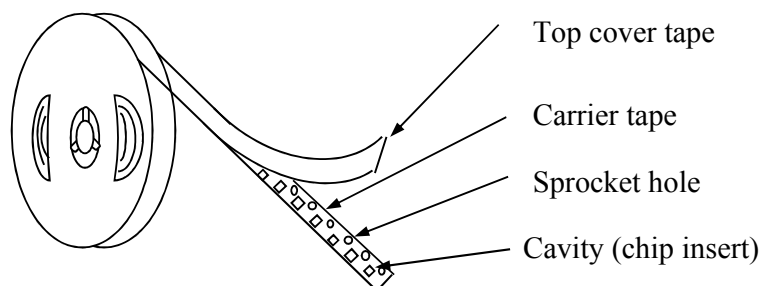

PRODUCT SPECIFICATION

SPEC. NO.

T-0622-063



7-4 Packaging Form

There shall not continuation more than two vacancies of the product.

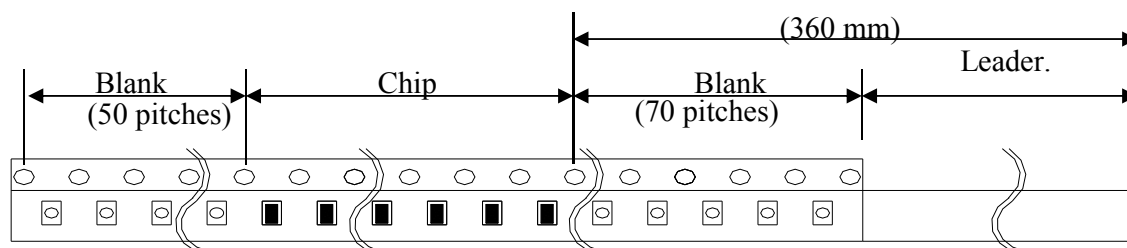

7-5 Cover Tape Peel Strength

The force for tearing off cover tape is 0.1~0.6(N) in the arrow direction at the following conditions:

Temperature : 5 ~ 35°C

Humidity : 45 ~ 85%

Atmospheric pressure : 860 ~ 1060 hpa

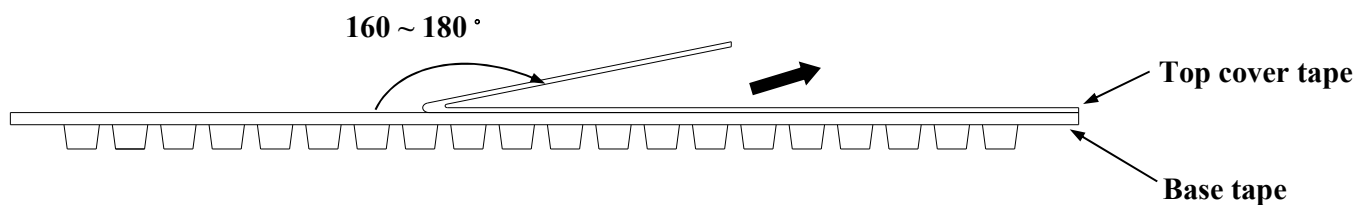

7-6 Packing Quantity

φ180 mm reel type : 2,000 pcs./reel

PRODUCT SPECIFICATION

SPEC. NO.

T-0622-063



8. Recommended Soldering Conditions (Please use this product by reflow soldering)

8-1 Recommended Footprint

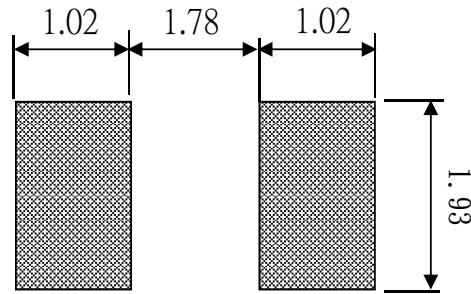

8-2 Recommended Reflow Pattern

Reflow : until two times

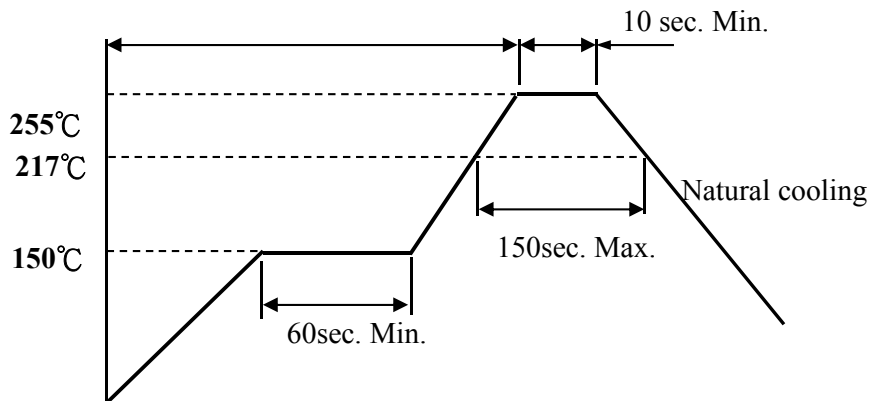

8-3 Iron Soldering

Use a solder iron of less than 30W when soldering, do not allow the soldering iron tip directly touch the Ceramic body outside of terminal electrode.

4 seconds max. at 260°C.

9. Attention in Case of Using

In case of using product, please avoid following matters:

Splashing water or salt water

Dew condenses

Toxic gas (Hydrogen sulfide, Sulfurous acid, Chlorine, Ammonia)

Vibrations or shocks which exceed the specified condition

Please be careful for the stress to this product by board flexure or something after the mounting.

10. Others

10-1 Operating temperature range : Ferrite Series : -25~+85°C

Ceramic Series : -40~+125°C

10-2 Storage condition : Temperature 20°~25°C, Relative Humidity 40%~60%

10-3 Recommended wire wound inductors should be used within 6 months from the time of delivery.

X-ON Electronics

Largest Supplier of Electrical and Electronic Components

Click to view similar products for [Fixed Inductors](#) category:

Click to view products by [EMTEK](#) manufacturer:

Other Similar products are found below :

[CR32NP-100KC](#) [CR32NP-151KC](#) [CR32NP-180KC](#) [CR32NP-181KC](#) [CR32NP-1R5MC](#) [CR32NP-390KC](#) [CR32NP-3R9MC](#) [CR32NP-680KC](#) [CR32NP-820KC](#) [CR32NP-8R2MC](#) [CR43NP-390KC](#) [CR43NP-560KC](#) [CR43NP-680KC](#) [CR54NP-181KC](#) [CR54NP-470LC](#) [CR54NP-820KC](#) [CR54NP-8R5MC](#) [70F224AI](#) [MGDQ4-00004-P](#) [MHL1ECTTP18NJ](#) [MHQ1005P10NJ](#) [MHQ1005P1N0S](#) [MHQ1005P2N4S](#) [MHQ1005P3N6S](#) [MHQ1005P5N1S](#) [MHQ1005P8N2J](#) [PE-51506NL](#) [PE-53601NL](#) [PE-53602NL](#) [PE-53630NL](#) [PE-53824SNLT](#) [PE-92100NL](#) [PG0434.801NLT](#) [PG0936.113NLT](#) [9220-20](#) [9310-16](#) [PM06-2N7](#) [PM06-39NJ](#) [A01TK](#) [1206CS-471XJ](#) [HC2LP-R47-R](#) [HC2-R47-R](#) [HC3-2R2-R](#) [HCF1305-3R3-R](#) [1206CS-151XG](#) [RCH664NP-140L](#) [RCH664NP-4R7M](#) [RCH8011NP-221L](#) [RCP1317NP-332L](#) [RCP1317NP-391L](#)