

# PRODUCT SPECIFICATION

SPEC. NO: T-0627-136B

DATE: Aug. 21, 2018

CUSTOMER'S PRODUCT NAME:

EMTEK PRODUCT NAME:

PIS2D10P-Series

THIS SPECIFICATION IS:

- FULLY ACCEPTED
- DENIED
- ACCEPTED UNDER THE FOLLOWING CONDITIONS



SIGNATURE: \_\_\_\_\_

DATE: \_\_\_\_\_

NAME(PRINT): \_\_\_\_\_

TITLE: \_\_\_\_\_

 **EMTEK CO., LTD.**

本文件內容全部或部份,未經兆欣科技股份有限公司同意不得以任何形式複製或其他用途  
All rights reserved.This document or parts thereof,may not be reproduced by any means or used in any manner without written permission of EMTEK CO.,LTD.

FACTORY:

39, Chingao Rd., (305)Hsinpu,  
Hsinchu Hsien, Taiwan, R. O. C

TEL: 03-5894-433

FAX: 03-5894-523

# PRODUCT SPECIFICATION

SPEC. NO.

T-0627-136B



## 1. Scope

This specification applies Ferrite Power Inductance PIS2D10P-Series to be delivered to user.

## 2. Product Identification

PIS 2D10P - 6R8 □ - T

(1) (2) (3) (4) (5)

- (1) Product name
- (2) Shapes and dimensions
- (3) Inductance  
6R8 : 6.8 uH
- (4) Tolerance  
M=±20% , N=±30%
- (5) Taping Type

## 3. Shapes and Dimensions

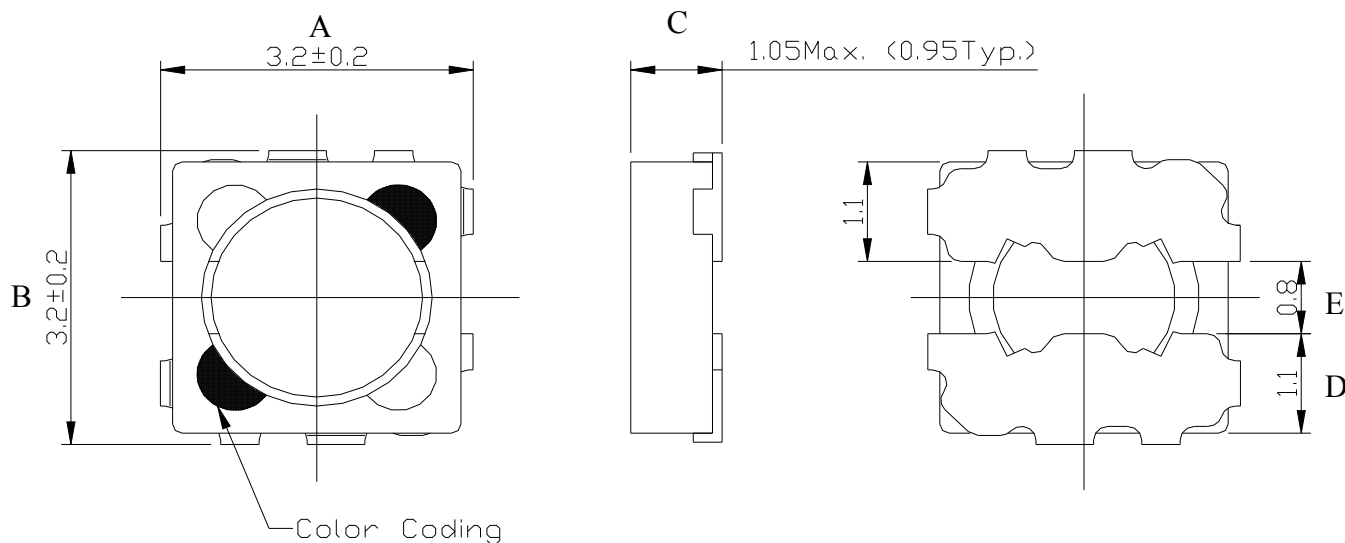

A:3.2±0.2 mm  
 B:3.2±0.2 mm  
 C:1.05 Max. (0.95Typ.)mm  
 D:1.10 mm  
 E:0.80

Drawn by	Checked by	Approved by
Cindy Mar. 30. 2017	Zheng Mar. 30. 2017	Sun Mar 30. 2017

# PRODUCT SPECIFICATION

SPEC. NO.

T-0627-136B



## 4. Electrical Characteristics

Customer Part Number	Our Product Part Number	Inductance (uH)/KHz	Inductance Tolerance	Rdc Typ (Ω)	Idc Typ (mA)		Irms Typ (mA)		Color Coding
					L ↓ 10%	L ↓ 35%	T ↑ 25°C	T ↑ 40°C	
	PIS2D10P-R33□-T	0.33/1	M N	0.030	1800	2400	2800	3400	Orange
	PIS2D10P-R68□-T	0.68/1	M N	0.055	1100	1500	2000	3000	White
	PIS2D10P-1R0□-T	1.0/1	M N	0.065	1100	1500	1800	2600	Gray
	PIS2D10P-1R2□-T	1.2/1	M N	0.070	1000	1400	1500	2250	Black
	PIS2D10P-1R5□-T	1.5/1	M N	0.087	1000	1360	1400	2000	Brown
	PIS2D10P-1R8□-T	1.8/1	M N	0.097	900	1240	1350	1750	Red
	PIS2D10P-2R2□-T	2.2/1	M N	0.136	800	970	1100	1500	Orange
	PIS2D10P-2R7□-T	2.7/1	M N	0.127	760	940	1100	1600	Yellow
	PIS2D10P-3R3□-T	3.3/1	M N	0.175	680	880	1000	1500	Green
	PIS2D10P-3R9□-T	3.9/1	M N	0.200	620	840	900	1200	Blue
	PIS2D10P-4R7□-T	4.7/1	M N	0.274	600	820	850	1150	Violet
	PIS2D10P-5R6□-T	5.6/1	M N	0.319	540	720	750	1100	Gray
	PIS2D10P-6R8□-T	6.8/1	M N	0.330	460	600	700	1000	White
	PIS2D10P-8R2□-T	8.2/1	M N	0.420	440	580	650	850	Black
	PIS2D10P-100□-T	10.0/1	M	0.470	420	540	600	750	Brown
	PIS2D10P-120□-T	12.0/1	M	0.675	320	440	550	700	Red
	PIS2D10P-150□-T	15.0/1	M	0.800	300	400	500	600	Orange
	PIS2D10P-180□-T	18.0/1	M	0.890	300	380	450	550	Yellow
	PIS2D10P-220□-T	22.0/1	M	1.100	260	320	400	500	Green
	PIS2D10P-270□-T	27.0/1	M	1.600	240	300	340	450	Black
	PIS2D10P-330□-T	33.0/1	M	1.600	220	280	340	450	Blue
	PIS2D10P-470□-T	47.0/1	M	2.430	180	220	240	330	Black

# PRODUCT SPECIFICATION

SPEC. NO.

T-0627-136B



- When ordering, please specify tolerance and packaging codes. Ex: PIS2D10P-3R3M-T  
Tolerance : M= $\pm 20\%$  , N = $\pm 30\%$   
Packaging : Clear tape and reel { standard }.
- L, I<sub>dc</sub> : Agilent/HP 4284A Precision LCR Meter , 1KHz with 1V.
- R<sub>dc</sub> : Chroma Milliohmmeter 16502, or equivalent. (Typ:  $\pm 30\%$  tolerance)
- I<sub>dc</sub> for Inductance drop 10% or 35% from its value without current.
- I<sub>rms</sub> for a 25°C or 40°C rise above 25°C ambient.
- Operating temperature range from -40°C to 105°C.

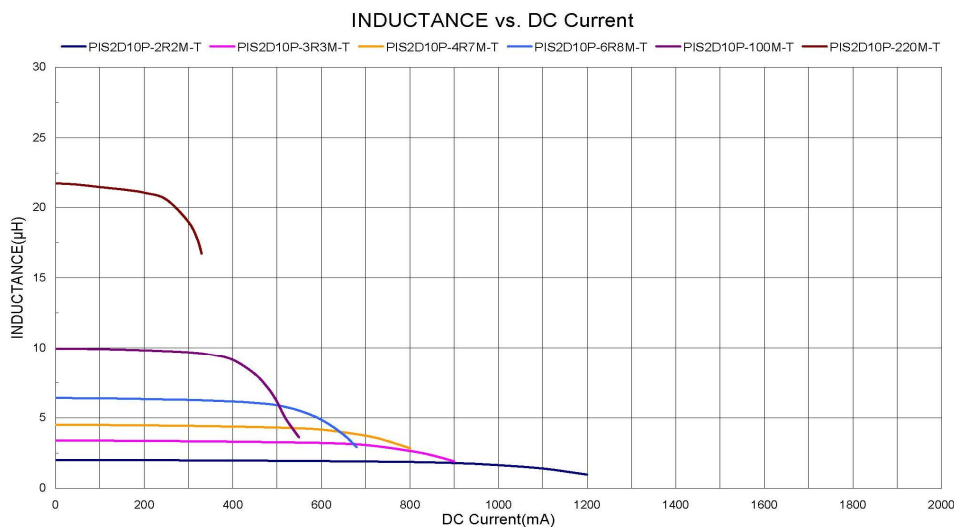
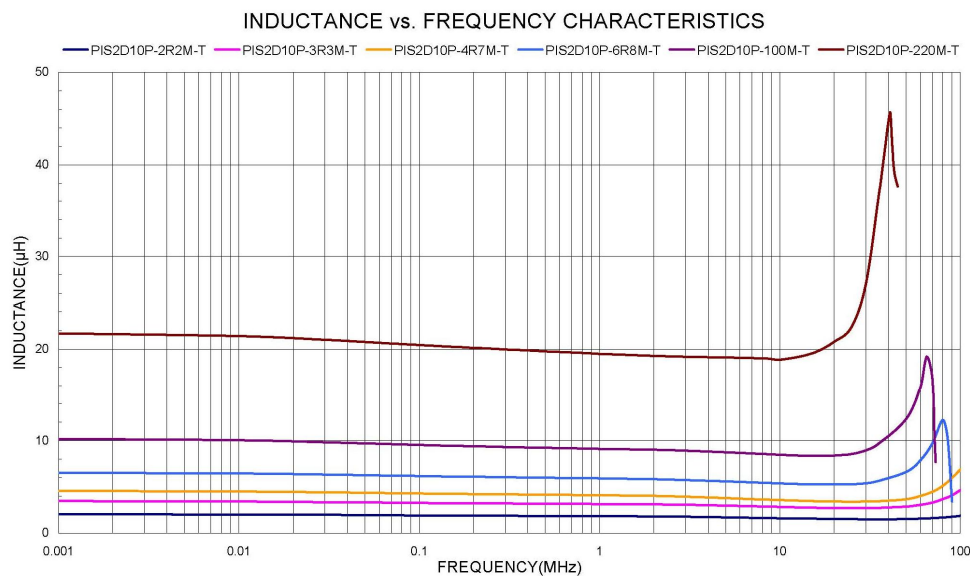

# PRODUCT SPECIFICATION

SPEC. NO.

T-0627-136B

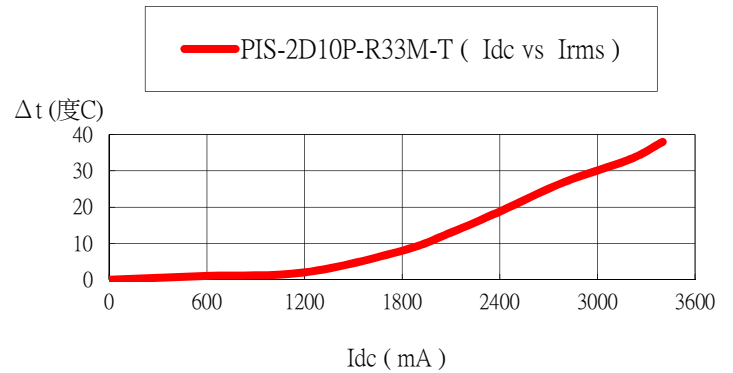
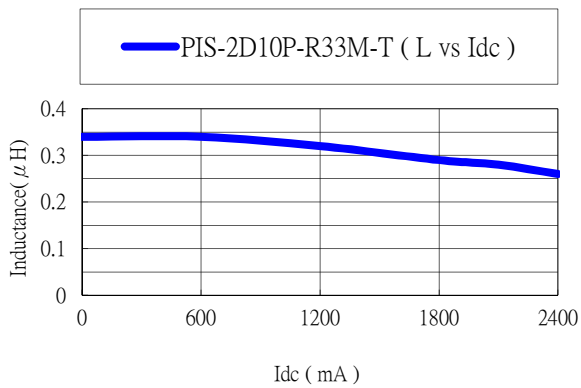
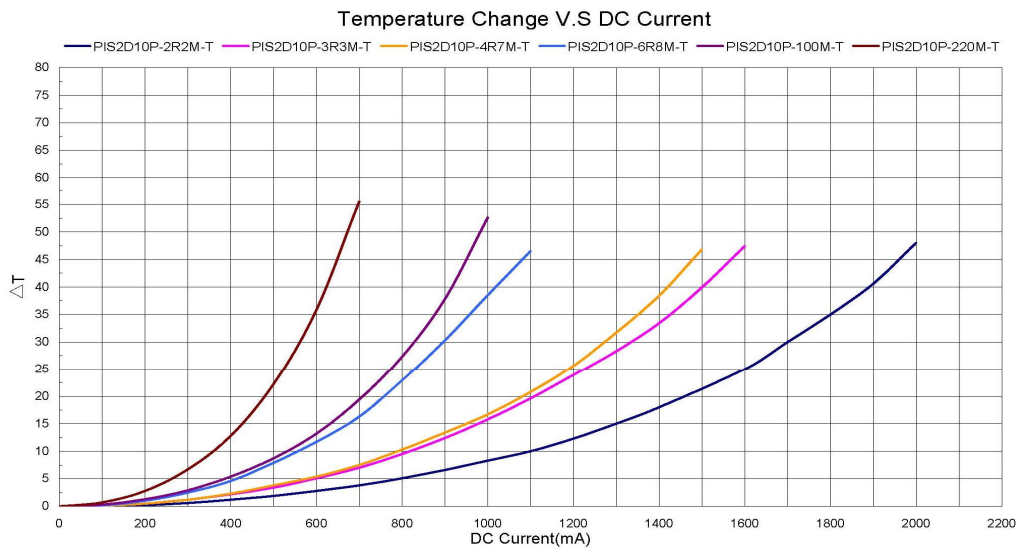

## 5. Material list

Item	Material
Core	Ferrite core
Wire	Copper wire
Epoxy	Epoxy
Base	Copper

# PRODUCT SPECIFICATION

SPEC. NO.

T-0627-136B



## 6. Reliability Test

Item	Specifications	Test conditions
Solderability	The metalized area must have 90% minimum solder coverage.	Dip pads in flux and dip in solder pot( 96.5 Sn/3.5 Ag solder) at 255°C ±5°C.
Resistance to soldering heat	There must be no case deformation or change in dimensions. Inductance must not change more than the stated tolerance.	Inductors shall be reflowed onto a PC board using 96.5 Sn/3.5 Ag solder paste. Solder process shall be at a maximum temperature of 260°C. For 96.5 Sn/3.5 Ag solder paste:>217°C for 90 seconds
High temperature resistance	There must be no case deformation or change in dimensions. Inductance must not change more than the stated tolerance.	Inductors shall be subjected to temperature 105±2°C for 50±12 hours. Measure the test items after leaving the inductors at room temperature and humidity for 2 hours.
Static Humidity	Inductors must not have a shorted or openwinding.	Inductors shall be subjected to temperature 85±2°C and 90 to 95%RH. for ten 24-hours. Measure the test items after leaving the inductors at room temperature and humidity for 2 hours.
Component adhesion (push test)	Inductors shall be subjected to 0.5Kg	Inductors shall be reflow soldered (255°C ±5°C for 10 seconds) to a tinned copper substrate. A force gauge shall be applied to the side of the component. The device must withstand the stated force without a failure of the termination.
Low temperature resistance	There must be no case deformation or change in dimensions. Inductance must not change more than the stated tolerance.	Inductors shall be subjected to temperature -40±2°C for 48±12 hours. Measure the test items after leaving the inductors at room temperature and humidity for 1 to 2 hours.

# PRODUCT SPECIFICATION

SPEC. NO.

T-0627-136B

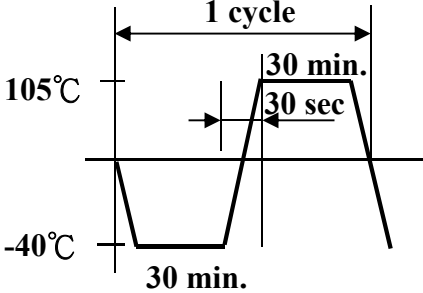

Item	Specifications	Test conditions
Resistance to solvent	There must be no case deformation, change in dimensions, or obliteration of marking.	Inductors must withstand 6 minutes of alcohol or water.
Thermal shock	There must be no case deformation or change in dimensions. Inductance must not change more than the stated tolerance.	Inductors shall be subjected to 10 cycles to the the following temperature cycle: <div style="text-align: center;">  <p>The diagram illustrates a temperature cycle. It starts at a baseline, drops to -40°C, where it remains for 30 minutes. It then rises to 105°C, where it remains for 30 seconds. Finally, it rises to 105°C, where it remains for 30 minutes. The entire sequence is labeled as '1 cycle'.</p> </div> <p>Measure the test items after leaving the inductors at room temperature and humidity for 2 hours.</p>

# PRODUCT SPECIFICATION

SPEC. NO.

T-0627-136B

## 7. Packaging

The packaging must be done not to receive any damage during transporting and storing.

### 7-1 Tape dimensions

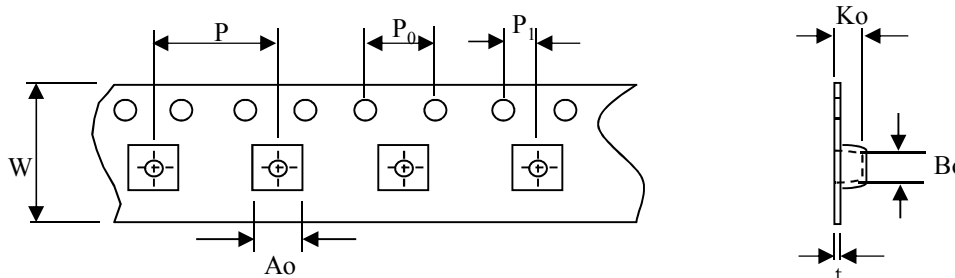

( Dimensions in mm; Tolerance :  $\pm 0.1$  )

Symbol	W	P	P <sub>0</sub>	P <sub>1</sub>	A <sub>0</sub>	Bo	Ko	t
Dimension	12	8	4	2	3.5	3.5	1.15	0.25

### 7-2 Reel dimensions

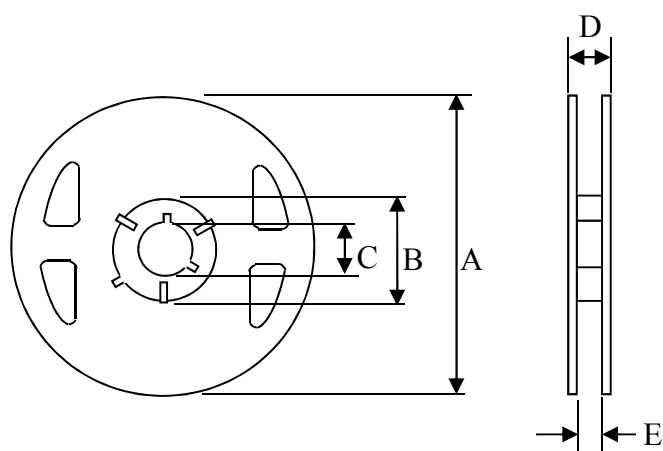

( Dimensions in mm )

Symbol	T
A	180
B	60
C	13
D	16
E	13.2

### 7-3 Tapping figure

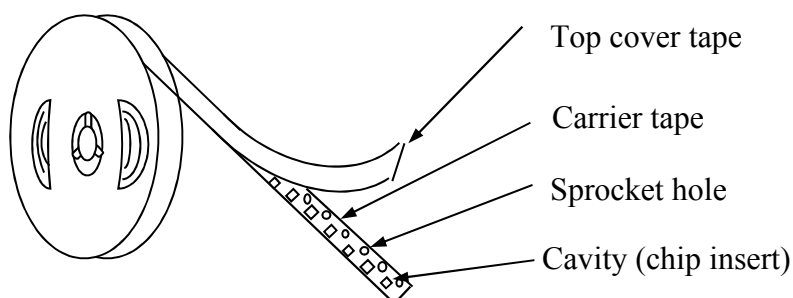



# PRODUCT SPECIFICATION

SPEC. NO.

T-0627-136B



## 7-4 Packaging Form

There shall not continuation more than two vacancies of the product.

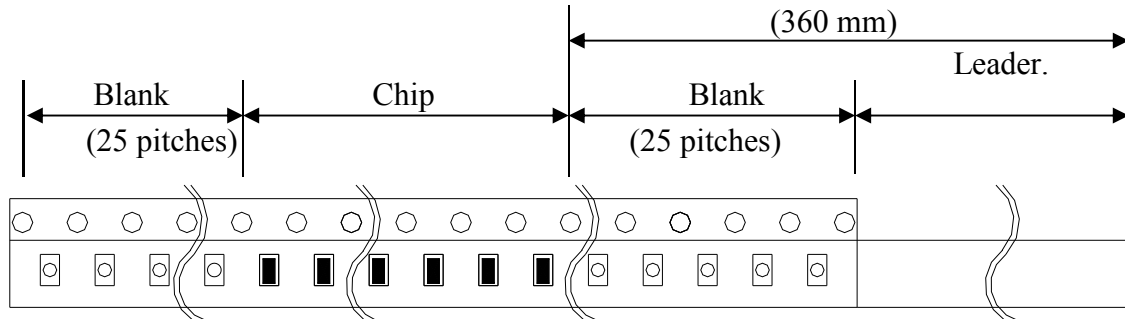

## 7-5 Cover Tape Peel Strength

The force for tearing off cover tape is 0.1~0.6(N) in the arrow direction at the following conditions:

Temperature : 5 ~ 35°C

Humidity : 45 ~ 85%

Atmospheric pressure : 860 ~ 1060 hpa

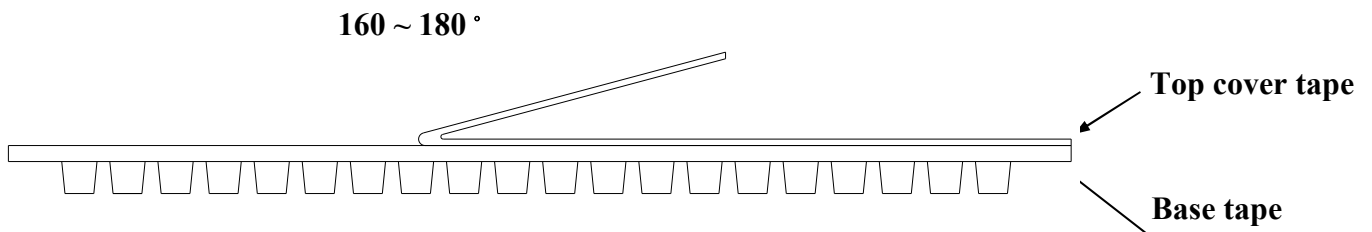

## 7-6 Packing Quantity

φ180 mm reel type : 1,000 pcs./reel

# PRODUCT SPECIFICATION

SPEC. NO.

T-0627-136B



## 8. Recommended Soldering Conditions (Please use this product by reflow soldering)

### 8-1 Recommended Footprint

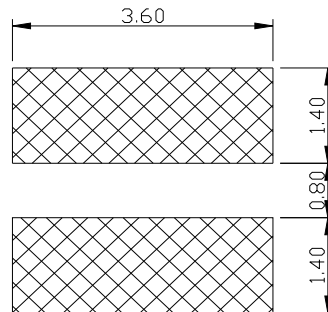

Recommand Pad Layout

Unit: mm

### 8-2 Recommended Reflow Pattern

Reflow : until two times

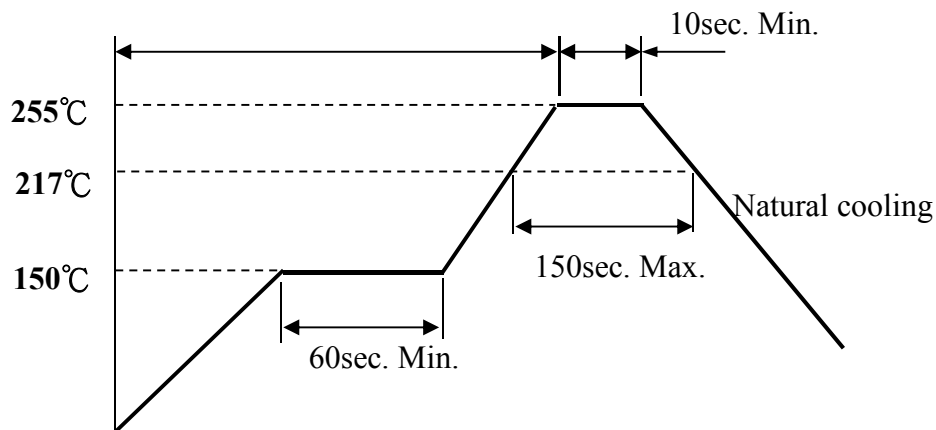

### 8-3 Iron Soldering

Use a solder iron of less than 30W when soldering ,do not allow the soldering iron tip directly touch the Ceramic body outside of terminal electrode.

5 seconds max. at 260°C.

## 9. Attention in Case of Using

In case of using product ,please avoid following matters:

Splashing water or salt water

Dew condenses

Toxic gas (Hydrogen sulfide, Sulfurous acid ,Chlorine, Ammonia)

Vibrations or shocks which exceed the specified condition

Please be careful for the stress to this product by board flexure or something after the mounting.

## 10. Others

10-1 Operating temperature range : Ferrite Series :-40~+105°C

10-2 Storage condition : Temperature 20~25°C , Relative Humidity 40%~60%

10-3 Recommended wire wound inductors should be used within 6 months from the time of delivery.

## X-ON Electronics

Largest Supplier of Electrical and Electronic Components

*Click to view similar products for [Fixed Inductors](#) category:*

*Click to view products by [EMTEK](#) manufacturer:*

Other Similar products are found below :

[CR32NP-100KC](#) [CR32NP-151KC](#) [CR32NP-180KC](#) [CR32NP-181KC](#) [CR32NP-1R5MC](#) [CR32NP-390KC](#) [CR32NP-3R9MC](#) [CR32NP-680KC](#) [CR32NP-820KC](#) [CR32NP-8R2MC](#) [CR43NP-390KC](#) [CR43NP-560KC](#) [CR43NP-680KC](#) [CR54NP-181KC](#) [CR54NP-470LC](#) [CR54NP-820KC](#) [CR54NP-8R5MC](#) [70F224AI](#) [MGDQ4-00004-P](#) [MHL1ECTTP18NJ](#) [MHQ1005P10NJ](#) [MHQ1005P1N0S](#) [MHQ1005P2N4S](#) [MHQ1005P3N6S](#) [MHQ1005P5N1S](#) [MHQ1005P8N2J](#) [PE-51506NL](#) [PE-53601NL](#) [PE-53602NL](#) [PE-53630NL](#) [PE-53824SNLT](#) [PE-92100NL](#) [PG0434.801NLT](#) [PG0936.113NLT](#) [9220-20](#) [9310-16](#) [PM06-2N7](#) [PM06-39NJ](#) [A01TK](#) [1206CS-471XJ](#) [HC2LP-R47-R](#) [HC2-R47-R](#) [HC3-2R2-R](#) [HCF1305-3R3-R](#) [1206CS-151XG](#) [RCH664NP-140L](#) [RCH664NP-4R7M](#) [RCH8011NP-221L](#) [RCP1317NP-332L](#) [RCP1317NP-391L](#)