

# *DMS technologies*

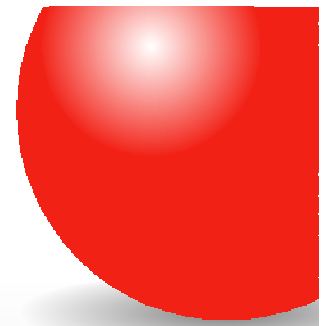

## **Hawker Cyclon**

### **Valve Regulated Lead Acid Battery**

#### **Application Manual**



Cyclon cells are manufactured by  
Hawker Energy Products Inc.

Revised March 2000

ENGINEERING WITH ENERGY

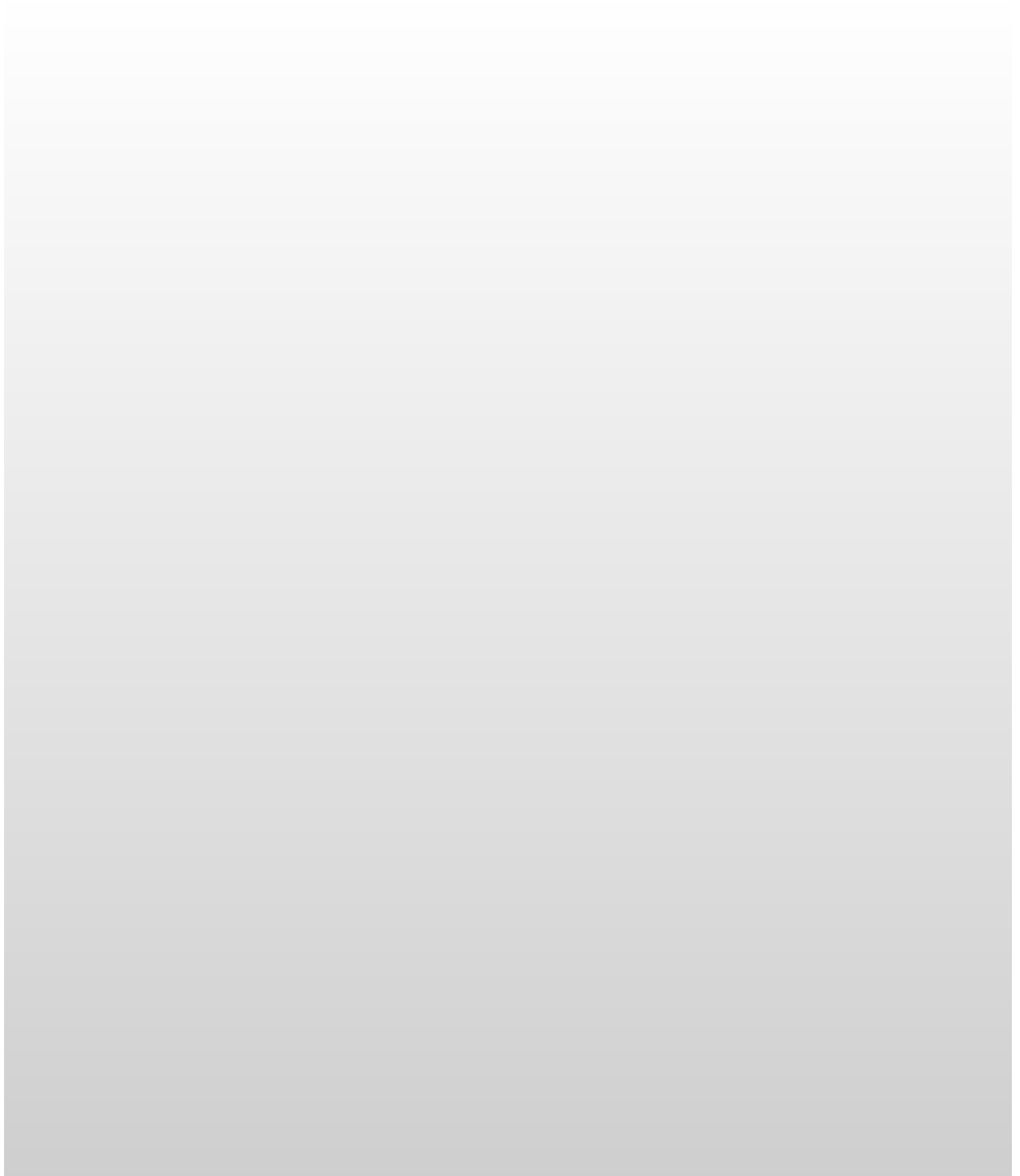

# Hawker Cyclon Valve Regulated Lead Acid Battery

## Application Manual



<b>Introduction</b>	<b>Page 4</b>
<b>Performance Characteristics</b>	<b>Page 4</b>
<b>Storage</b>	<b>Page 5</b>
<b>Charging</b>	<b>Page 5</b>
<b>Service Life</b>	<b>Page 6</b>
<b>Safety Precautions, Disposal and Transportation</b>	<b>Page 7</b>
<b>Discharge Characteristics</b>	<b>Page 7</b>
<b>Cyclon 2V single cell Technical specifications</b>	<b>Page 9</b>
<b>Cyclon Battery Packs</b>	<b>Page 10</b>
<b>Cyclon 4V Monobloc Technical Specifications</b>	<b>Page 12</b>
<b>Cyclon 6V Monobloc Technical Specifications</b>	<b>Page 13</b>
<b>Cyclon Monobloc Dimensions</b>	<b>Page 14</b>
<b>Cyclon Monobloc Configurations</b>	<b>Page 15</b>

## Introduction to Cyclon Cells and Monoblocs

Cyclon Valve Regulated Lead Acid (VRLA) Cells and Monoblocs are a unique technology using wound electrodes made of pure lead (99.99%) alloyed with 0.65% of tin.

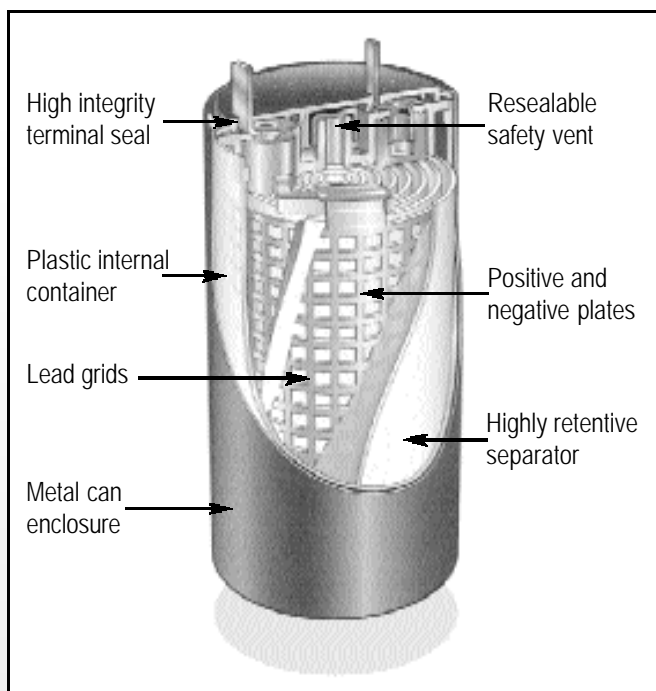

Gasses produced in normal overcharge are recombined within the cell. A re-sealable bunsen valve is incorporated to permit gas venting in the case of abusive overcharge.

Both Cyclon Cells and Cyclon Monoblocs can be charged and discharged in any attitude.

Both Cells and Monoblocs can be assembled into many different configurations providing maximum design flexibility.

Product can be transported by land, sea and air as non-hazardous cargo. Cyclon Cells are a recognised component meeting UL924 and UL1778. Cyclon Monoblocs meet UL924.

## Performance Characteristics

Cyclon Cells and Monoblocs have outstanding performance in the following areas.

- Long float life - Cyclon Cells: 15 years at 20°C.  
- Cyclon Monoblocs: 10 years at 20°C
- Long storage life (greater than 2 years at 25°C before recharge is necessary).
- Exceptional high rate discharge (Up to 26C).
- Wide operating temperature range  
- Cyclon Cells -65°C to +80°C  
- Cyclon Monoblocs -40°C to +40°C

- Very high shock and vibration resistance in all planes.

Cycle life up to 2500 cycles at 30% DOD.

## Discharge Characteristics

Maximum current capabilities		
Cyclon Type	Pulse Amps	Continuous Amps
D Single Cell (2.5 Ah)	200	65
D Monobloc (2.5 Ah)	200	50
TD Single Cell (4.5 Ah)	200	65
X Single Cell (5.0 Ah)	285	65
X Monobloc (5.0 Ah)	285	50
E Single Cell (8.0 Ah)	330	65
E Monobloc (8.0 Ah)	330	50
J Single Cell (12.5Ah)	400	65
BC Single Cell (25.0 Ah)	665	250

Table 1

The extremely low internal resistance of Cyclon cells gives excellent voltage regulation on discharge which is equal to or better than other VRLA systems.

As with all lead battery systems discharge energy available is reduced as temperature decreases.

Variation of discharge capacity with temperature.		
% of rated C/10 Capacity Available		
Temp °C	C/10	C
80	105	75
60	105	75
40	105	75
20	100	72
0	85	65
-20	70	50
-40	50	30

Table 2

*These values should be taken as a guide only.*

If the application fully discharges the battery it is recommended that a low voltage cut out is employed to protect the battery against overdischarge. The end of discharge voltage varies according to the rate of discharge (See Table 3). Overdischarging the battery can lead to recharging difficulties and also damage the battery. For design details of low voltages cut out circuits please contact our Customer Support Staff on +44 (0) 1794 830111.

Recommended minimum End of Discharge Voltage (EODV).	
Discharge Rate Amps	Min. EODV per cell
0.05C (C/20)	1.75V
0.10C (C/10)	1.70V
0.20C (C/5)	1.65V
0.40C (C/2.5)	1.65V
1.00C	1.60V
2.00C	1.55V
>5.00C	1.50V

Discharging the Cyclon cell below these voltage levels or leaving the cell connected to a load in a discharged state may impair the cell's ability to accept a charge.

Table 3

## Storage

The state of charge of the Cyclon cell can be estimated by using the graph below.

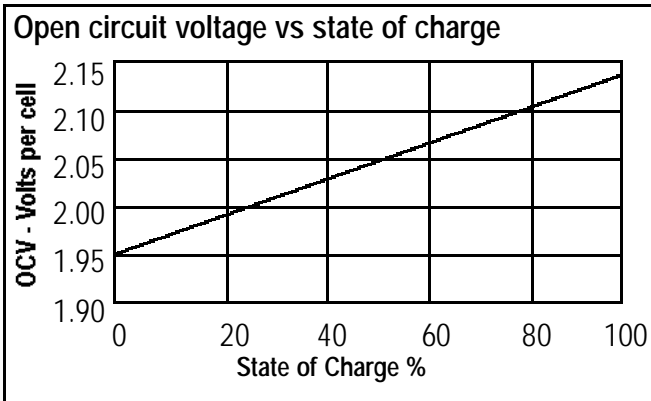

Table 4

Note:- This curve is accurate to within 20% of the cell's rated capacity, if it has not been charged or discharged within the past 24 hours. The curve is accurate to within 5% if the cell has not seen any activity, charge or discharge, for the past 5 days.

## Storage

Most batteries lose their stored energy when allowed to stand open circuit. The self discharge rate is dependent both on the system's chemistry and on the temperature at which the battery is stored. Lead-tin technology gives the lowest self discharge and the longest shelf life of any VRLA battery system. Storage life is shown in Table 5 and is dependent on temperature

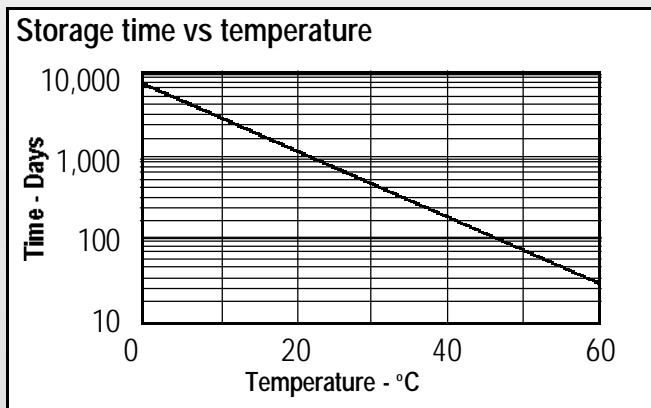

Table 5

Cyclon's self discharge rate is non linear. Table 6 indicates capacity remaining against time.

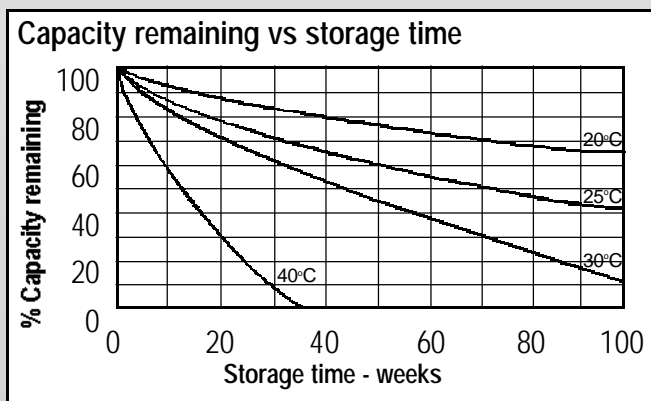

Table 6

## Charging

Constant Voltage Charging is the most efficient method of charging Cyclon VRLA products.

To obtain full recharge and maintain the capacity of the cell it is necessary to return a minimum of 110% of the energy that has been removed during the last discharge. Correct voltage setting and good voltage regulation of the charger are essential to maintain an acceptable battery life. Fast recharge is possible with Cyclon products although for economic reasons batteries are usually recharged at the C/10 or C/5 rate.

Voltage levels differ for float and cyclic applications.

The table below shows the correct charger voltage setting for both cyclic and float applications.

## Charge Voltages

Float charge = 2.27-2.35V per cell at 25°C

Cyclic charge = 2.45-2.5V per cell at 25°C

## Recharge Time

Cyclon products can be recharged to 95% capacity in under one hour. No current limit is necessary at either float or cyclic voltages. If a fast charge regime is used it is necessary to allow a longer period of recharge (typically 7 to 10 hours) every 7-10 cycles. This permits cells to fully recharge and ensures a maximum cycle life.

Charger Rating	Charge Voltage			
	2.3VPC (Float)		2.45VPC (Cyclic)	
	90% Rech.	100% Rech.	90% Rech.	100% Rech.
5C	-	-	0.5	7
C	-	-	1.5	8
C/5	7	45	6	16
C/10	12	50	11	24

Table 7

## Temperature Compensation

If operating temperatures are above 30°C or below 0°C temperature compensation should be applied to the charging voltage as shown below.

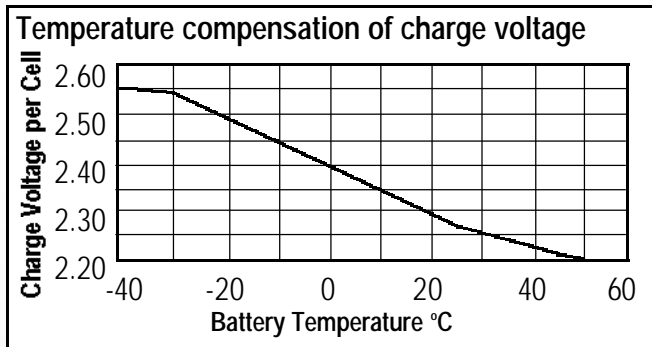

Table 8

### Two State Constant Voltage Charging

To allow fast recharge but maximise standby life, two level voltage charging can be used. Charging should commence at the cyclic rate and switch down to the float charge voltage after a preset time has elapsed. The time is established with reference to the charge current limit (See Table 7 page 5).

### Constant Current Charging

This technique can be used with Cyclon cells and Monoblocs providing charging is terminated before excessive overcharge occurs. Charge can be terminated by time or voltage sensing but long term overcharge must be limited to C/500. Please contact our Customer Support Staff for further assistance.

### Taper Charging

Although taper current chargers are the least expensive type of chargers, their lack of voltage regulation can be detrimental to the life of any cell type. Half wave rectification should be avoided because the high peak-to-average voltage ratio will reduce the service life of the cell. It is recommended that charge rate at 2.50 volts/cell be between C/50 and C/100 to prevent serious overcharge if the charger is left connected for extended periods.

The normal recharge time for a taper charger can be assessed by reference to the charge current available at charge voltage of 2.2VPC allowing for the return of 120% of discharged capacity.

### Other Charging Methods

For application engineering support on solar, vehicle systems or other charging methods please refer to our Customer Support Staff.

## Service Life

End of service life of Cyclon products is defined as the point when the battery delivers less than 80% of its rated capacity.

### Float Life

Cyclon cells have a design life of 15 years at 20°C for floating applications.

Cyclon Monoblocs have a design life of 10 years at 20°C for floating applications.

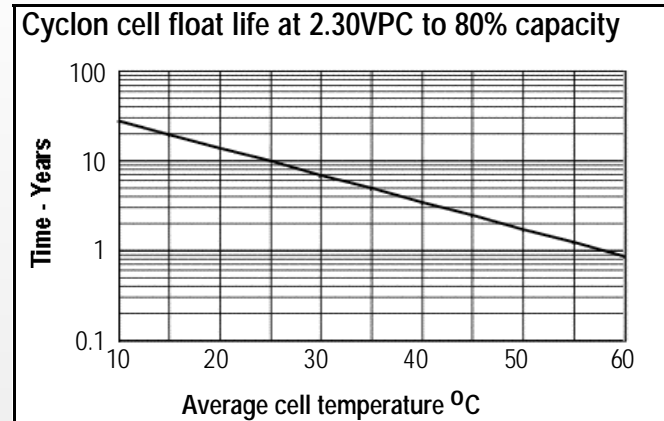

Table 9

### Cycle Life

Cycle Life varies with depth of discharge (D.O.D.)

DOD %	Cycle Life
100	300
80	450
60	700
25	1,600
10	3,000
5	10,000

Table 10  
N.B Service life is dependent on correct charging of the product and operating temperature.

## Safety Precautions, Disposal and Transportation

### Safety Precautions

1. Recombination technology is designed to contain and recombine gas produced in overcharge. In certain circumstances such as abusive overcharge gasses can be vented through the safety valve. To prevent any possibility of explosion.

*Never charge in a gas tight container*

2. Pure lead/tin batteries have a very low internal impedance and are capable of delivering very high currents if short circuited. The resultant heat could cause severe burns or a fire.

*Do not short circuit cells or batteries*

3. To ensure correct service life and operation.

*Use approved charging methods*

### Disposal

Cyclon products contain materials capable of being recycled and should be disposed of according to the laws governing the recycling of lead products.

### Transportation

All Cyclon products are classified as non-spillable wet lead acid batteries and can be shipped by land, sea and air as non-hazardous cargo.

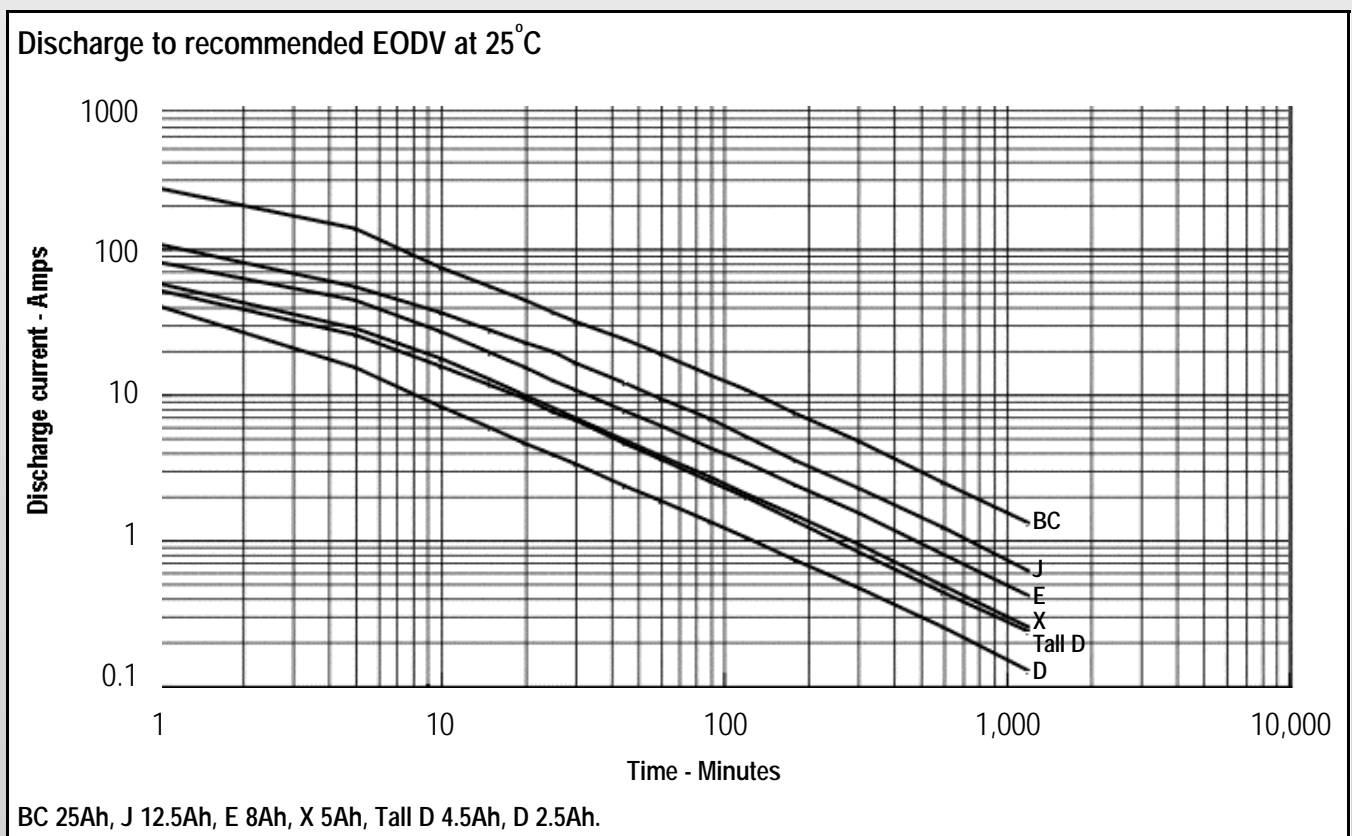

Table 11

## Tabular discharge data

### Cyclon 2V, 2.5Ah D cell and D monobloc Discharge: Constant Current (Amps) at 25°C

Run Time	1.85VPC	1.75VPC	1.67VPC	1.60VPC	1.50VPC
1 min	21.20	30.10	34.60	38.10	41.60
5 min	10.40	13.50	14.80	15.40	15.80
10 min	6.60	7.70	8.10	8.30	8.40
15 min	5.00	5.60	5.90	5.97	6.04
20 min	4.00	4.50	4.60	4.70	4.75
25 min	3.40	3.80	3.90	3.93	X
30 min	2.90	3.30	3.35	3.40	X
45 min	2.20	2.40	2.42	X	X
60 min	1.75	1.90	1.92	X	X
90 min	1.25	1.34	1.37	X	X
2 hr	1.00	1.05	1.07	X	X
3 hr	0.70	0.74	0.75	X	X
5 hr	0.45	0.47	0.48	X	X
10 hr	0.24	0.25	0.26	X	X
20 hr	0.12	0.13	0.13	X	X

Table 12

### Cyclon 2V 8.0Ah E cell and E monobloc. Discharge: Constant Current (Amps) at 25°C

Run Time	1.85VPC	1.75VPC	1.67VPC	1.60VPC	1.50VPC
1 min	46.00	60.50	69.50	72.20	81.00
5 min	31.30	38.00	41.70	44.00	45.67
10 min	20.20	24.40	26.40	27.10	27.70
15 min	15.90	18.30	19.00	19.40	19.70
20 min	13.00	14.70	15.20	15.50	15.60
25 min	11.10	12.30	12.70	12.90	X
30 min	9.70	10.70	11.00	11.10	X
45 min	7.10	7.70	7.90	X	X
60 min	5.67	6.10	6.20	X	X
90 min	4.10	4.38	4.40	X	X
2 hr	3.20	3.40	3.50	X	X
3 hr	2.30	2.40	2.46	X	X
5 hr	1.45	1.50	1.56	X	X
10 hr	0.75	0.80	0.81	X	X
20 hr	0.40	0.41	0.42	X	X

Table 15

### Cyclon 2V, 4.5Ah TD cell. Discharge: Constant Current (Amps) at 25°C

Run Time	1.85VPC	1.75VPC	1.67VPC	1.60VPC	1.50VPC
1 min	31.00	42.00	49.50	53.20	57.80
5 min	17.70	20.60	22.80	25.50	26.20
10 min	12.40	13.90	14.90	16.00	16.10
15 min	9.70	10.60	11.20	11.80	11.90
20 min	8.00	8.60	9.10	9.40	9.50
25 min	6.70	7.20	7.60	7.80	X
30 min	5.90	6.30	6.60	6.80	X
45 min	4.30	4.60	4.70	X	X
60 min	3.40	3.60	3.70	X	X
90 min	2.40	2.50	2.60	X	X
2 hr	1.90	1.90	2.00	X	X
3 hr	1.30	1.30	1.40	X	X
5 hr	0.82	0.84	0.85	X	X
10 hr	0.43	0.44	0.45	X	X
20 hr	0.22	0.23	0.34	X	X

Table 13

### Cyclon 2V 12.5Ah J cell. Discharge: Constant Current (Amps) at 25°C

Run Time	1.85VPC	1.75VPC	1.67VPC	1.60VPC	1.50VPC
2 min	33.5	49.6	63.3	74.0	82.9
5 min	32.2	40.6	47.1	51.8	55.8
10 min	25.9	30.1	33.2	35.4	37.2
15 min	21.4	24.1	26.0	27.3	28.4
20 min	18.3	20.1	21.4	22.3	23.1
25 min	16.25	17.7	18.7	19.4	20.1
30 min	14.2	15.3	16.0	16.5	17.0
45 min	10.7	11.3	11.7	12.0	12.3
60 min	8.6	9.0	9.3	9.5	9.6
90 min	6.7	7.0	7.2	7.3	X
2 hr	4.8	5.0	5.1	5.2	X
3 hr	3.4	3.5	3.6	X	X
5 hr	2.1	2.2	2.3	X	X
10 hr	1.1	1.2	X	X	X
20 hr	0.6	X	X	X	X

Table 16

### Cyclon 2V 5.0Ah X cell and X monobloc Discharge: Constant Current (Amps) at 25°C

Run Time	1.85VPC	1.75VPC	1.67VPC	1.60VPC	1.50VPC
1 min	33.60	44.20	50.70	54.90	59.20
5 min	20.00	24.90	27.30	28.30	29.00
10 min	13.40	16.60	17.80	18.40	18.80
15 min	10.20	12.30	13.20	13.60	13.80
20 min	8.20	9.60	10.00	10.20	10.30
25 min	7.00	7.90	8.20	8.30	X
30 min	6.10	6.80	7.00	7.10	X
45 min	4.40	4.90	5.00	X	X
60 min	3.50	3.80	3.90	X	X
90 min	2.50	2.70	2.75	X	X
2 hr	2.00	2.10	2.14	X	X
3 hr	1.40	1.48	1.51	X	X
5 hr	0.90	0.95	0.96	X	X
10 hr	0.47	0.50	0.50	X	X
20 hr	0.24	0.24	0.26	X	X

Table 14

### Cyclon 2V 25.0Ah BC cell. Discharge: Constant Current (Amps) at 25°C

Run Time	1.85VPC	1.75VPC	1.67VPC	1.60VPC	1.50VPC
1 min	122.90	167.20	199.00	235.00	268.50
5 min	78.90	102.20	118.30	130.50	141.20
10 min	58.10	68.50	72.80	74.70	76.40
15 min	45.60	52.30	54.30	55.30	56.20
20 min	37.70	42.30	43.70	44.40	45.10
25 min	32.80	35.90	36.90	37.40	X
30 min	29.20	31.60	32.00	32.60	X
45 min	22.00	24.00	24.40	X	X
60 min	17.75	18.90	19.30	X	X
90 min	13.10	13.80	14.00	X	X
2 hr	10.20	10.90	11.10	X	X
3 hr	7.10	7.50	7.60	X	X
5 hr	4.60	4.80	4.85	X	X
10 hr	2.40	2.50	2.55	X	X
20 hr	1.25	1.32	1.33	X	X

Table 17

*X indicates that the cell should not be discharged at this rate to the specified EODV.*



## Cyclon 2V single cell technical specifications at 25°C

Cell type	Product Number	Volts	Nominal Capacity (10hr rate to 1.67VPC) (Ah)	Dimensions(mm)			Weight (Kg)	Tabs (mm)
				Dia	Ht	Ht over tabs		
D cell (2.5Ah)	0810-0004	2	2.5	34	61	68	0.18	4.75x0.64
Tall D cell (4.5Ah)	0860-0004	2	4.5	34	96	103	0.27	4.74x0.64
X cell (5.0Ah)	0800-0004	2	5.0	44	73	82	0.36	6.35x0.64
E cell (8.0Ah)	0850-0004	2	8.0	44	100	109	0.55	6.35x0.64
J cell (12.5Ah)	0840-0004	2	12.5	51.8	123.4	136	0.84	7.92x0.81
BC cell (25Ah)	0820-0004	2	25.0	65	159	174	1.70	M8+ & M6- studs

Table 18

	D Cell	Tall D Cell	X Cell	E Cell	J cell	BC cell
<b>Internal resistance of fully charged cell (m Ω)</b>	5.0	5.0	3.5	3.0	2.5	1.5
<b>Nominal short circuit current for charged cell</b>	400A	400A	570A	665A	800A	1335A
<b>Temperature Range</b>						
Storage	-65°C to +80°C					
Discharge	-65°C to +80°C					
Charge	-40°C to +80°C					
<b>Maximum recommended storage time before recharge</b>	24 months @ 25°C or 2.0VPC, whichever is earlier. Stock should be checked at 6 month intervals or more frequently if the temperature exceeds +25°C					
<b>Safety Pressure Release Valve</b>	50 psi (all cells) 3 atmospheres					
<b>Atmospheric Pressure Range</b>	Vacuum to 8 atmospheres					
<b>Life expectancy (to 80% of rated capacity)</b>						
Cycle Life (100% DOD, C/5)	300					
Cycle life (5% DOD)	10,000					
Float Life at 25°C	10 years					
Float life at 20°C	15 years					
<b>Charging</b>	Constant Voltage (Cyclic) 2.45-2.50VPC Constant Voltage (Floating) 2.27-2.35VPC N.B. No current limit is required when using a voltage regulated charger. Constant Current charging - please contact DMS for specific data.					

### Caution

Batteries contain toxic materials (Lead, Sulphuric Acid).  
Avoid short circuit.  
Do not charge in gas tight container.  
Sealed lead rechargeable battery.  
Must be recycled or disposed of properly.

## Cyclon Battery Packs

Product Number	Description	Dimensions (mm)			Weight (Kg)
		L	W	H	
9810-0075	12V 2.5Ah 1x6 ABS Leads	209	39	68	1.19
9810-0016	12V 2.5Ah 1x6 ABS Tags	209	39	68	1.19
9810-0109	12V 2.5Ah 1x6 s/w Leads	203	38	67	1.13
9810-0108	12V 2.5Ah 1x6 s/w Tags	203	38	67	1.13
9810-0067	12V 2.5Ah 2x3 ABS Leads	107	73	68	1.19
9810-0008	12V 2.5Ah 2x3 ABS Tags	107	73	68	1.19
9810-0115	12V 2.5Ah 2x3 s/w Leads	102	72	67	1.13
9810-0114	12V 2.5Ah 2x3 s/w Tags	102	72	67	1.13
9800-0072	12V 5Ah 1x6 ABS Leads	270	49	79	2.40
9800-0016	12V 5Ah 1x6 ABS Tags	270	49	79	2.40
9800-0109	12V 5Ah 1x6 s/w Leads	264	46	78	2.35
9800-0108	12V 5Ah 1x6 s/w Tags	264	46	78	2.35
9800-0047	12V 5Ah 2x3 ABS Leads	138	93	79	2.40
9800-0008	12V 5Ah 2x3 ABS Tags	138	93	79	2.40
9800-0115	12V 5Ah 2x3 s/w Leads	133	91	78	2.35
9800-0114	12V 5Ah 2x3 s/w Tags	133	91	78	2.35
9810-0077	6V 2.5Ah 1x3 ABS Leads	107	39	68	0.60
9810-0011	6V 2.5Ah 1x3 ABS Tags	107	39	68	0.60
9810-0103	6V 2.5Ah 1x3 s/w Leads	102	38	67	0.56
9810-0102	6V 2.5Ah 1x3 s/w Tags	102	38	67	0.56
9800-0071	6V 5Ah 1x3 ABS Leads	138	49	79	1.18
9800-0011	6V 5Ah 1x3 ABS Tags	138	49	79	1.18
9800-0103	6V 5Ah 1x3 s/w Leads	133	47	78	1.12
9800-0102	6V 5Ah 1x3 s/w Tags	133	47	78	1.12

6 volt Shrink wrap.

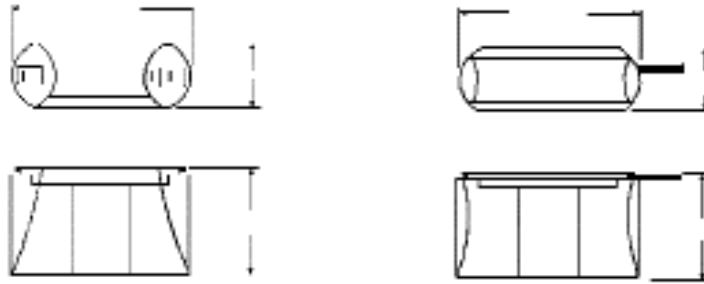

6 volt ABS case.

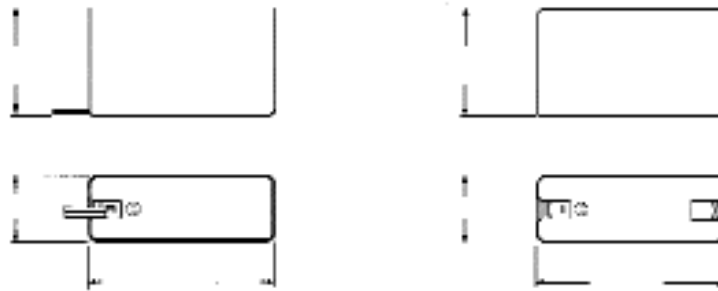

12 volt 1x6 Shrink wrap.

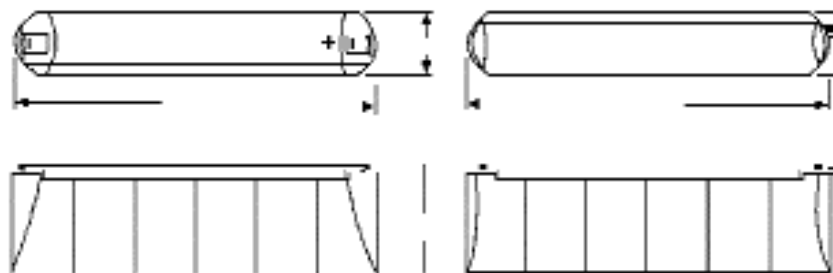

12 volt 2x3 Shrink wrap.

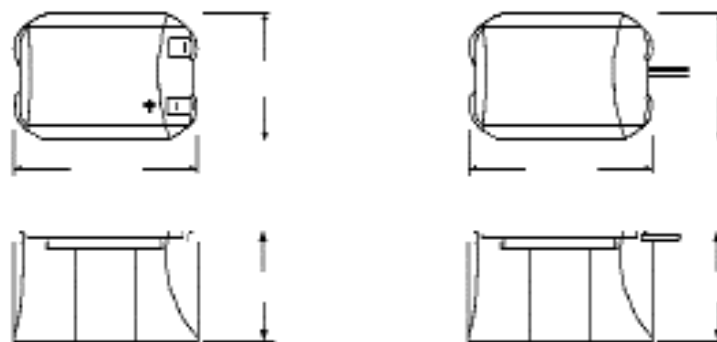

12 volt 2x3 ABS case.

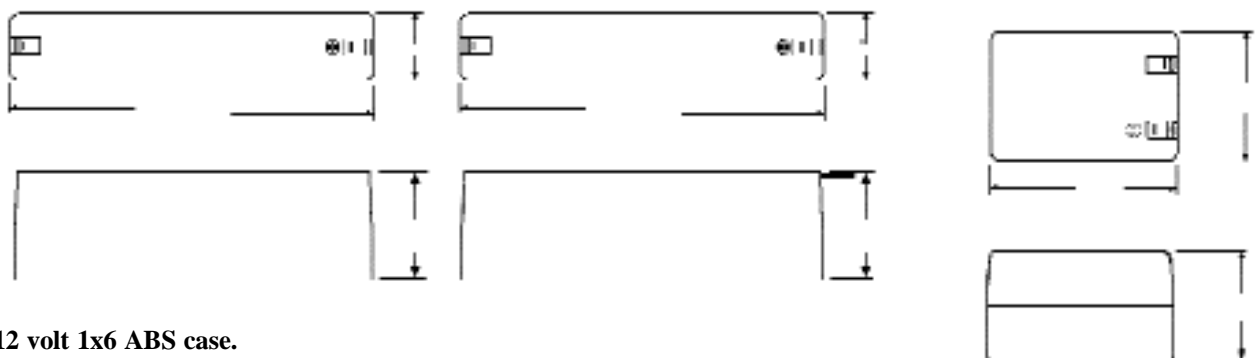

12 volt 1x6 ABS case.

## Cyclon 4V Monobloc technical specifications

	<b>D (2.5Ah)</b>	<b>X (5.0Ah)</b>	<b>E (8.0Ah)</b>
<b>Part number</b>	0819-0010	0809-0010	0859-0010
<b>Capacity to 1.67 vpc.</b>			
10 hour rate	2.50Ah	5.00Ah	8.00Ah
1 hour rate	1.95Ah	3.99Ah	6.24Ah
15 minute rate	1.49Ah	3.40Ah	4.75Ah
<b>Maximum overall dimensions in. (mm).</b>			
Length	3.13 (79.5)	3.80 (96.5)	3.81 (96.8)
Width	1.81 (46.0)	2.12 (53.8)	2.13 (54.1)
Height	2.75 (69.85)	3.02 (76.71)	4.00 (101.60)
Weight lb. (kg)	.80 (0.36)	1.62 (.74)	2.11 (.96)
<b>Internal resistance of fully charged monobloc, mΩ at 25°C.</b>	10.0	7.0	6.0
<b>Nominal battery voltage</b>	4.0	4.0	4.0
<b>Nominal short circuit level for charged battery</b>	400A	570A	665A
<b>Temperature range</b>			
Storage	-40°C to +40°C	-40°C to +40°C	-40°C to +40°C
Discharge	-40°C to +40°C	-40°C to +40°C	-40°C to +40°C
Charge	-40°C to +40°C	-40°C to +40°C	-40°C to +40°C
<b>Maximum recommended storage time before recharge</b>	24 months @ 25°C or 2.0vpc, whichever is earlier.		
<b>Safety pressure relief valve</b>	8psi 0.5Atm	8psi 0.5Atm	8psi 0.5Atm
<b>Atmospheric pressure range</b>	Vacuum to 2 atmospheres		
<b>Charging, per 4V battery at 25°C</b>			
Constant voltage (cyclic)	4.90 to 5.0	4.90 to 5.0	4.90 to 5.0
Constant voltage (float)	4.54 to 4.70	4.54 to 4.70	4.54 to 4.70
N.B. No current limit is required when using a voltage regulated charger. Constant Current charging - please contact DMS for specific data.			
<b>Life expectancy (to 80% of rated capacity)</b>			
Cycle Life, 100% DOD, C/5	300*	300*	300*
Float life at 20°C, based on accelerated test methods, 6.8 volts constant voltage charge at 20°C ambient temperature	10 years	10 years	10 years
<b>Mounting</b>	Each monobloc is quipped with 0.216 in./5.49mm. mounting holes in the cover. The tightening torque for mounting the monobloc is 25in-lbs. When using 4 mounting bolts, small spacers (washers) 1 to 3mm. thick should be placed between the battery and the mounting surface to prevent bowing or stessing the battery case.		

**UL Recognised component. Meets UL 924**

\*300 cycles at 100% depth of discharge; one cycle per, C/5 (Charge: 7.50V constant voltage, 3C current limit; 16 hour charge).

## Cyclon 6V Monobloc technical specifications

	<b>D (2.5Ah)</b>	<b>X (5.0Ah)</b>	<b>E (8.0Ah)</b>
<b>Part number</b>	0819-0012	0809-0012	0859-0012
<b>Capacity to 1.67 vpc.</b>			
10 hour rate	2.50Ah	5.00Ah	8.00Ah
1 hour rate	1.95Ah	3.99Ah	6.24Ah
15 minute rate	1.49Ah	3.40Ah	4.75Ah
<b>Maximum overall dimensions in. (mm).</b>			
Length	4.45 (113.03)	5.47 (138.94)	5.47 (138.94)
Width	1.79 (45.47)	2.11 (53.59)	2.11 (53.59)
Height	2.75 (69.85)	3.02 (76.71)	4.00 (101.60)
Weight lb. (kg)	1.15 (0.52)	2.16 (.98)	3.15 (1.43)
<b>Internal resistance of fully charged monobloc, mΩ at 25°C.</b>	15.0	10.0	8.0
<b>Nominal battery voltage</b>	6.0	6.0	6.0
<b>Nominal short circuit level for charged battery</b>	400A	570A	665A
<b>Temperature range</b>			
Storage	-40°C to +40°C	-40°C to +40°C	-40°C to +40°C
Discharge	-40°C to +40°C	-40°C to +40°C	-40°C to +40°C
Charge	-40°C to +40°C	-40°C to +40°C	-40°C to +40°C
<b>Maximum recommended storage time before recharge</b>	24 months @ 25°C or 2.0vpc, whichever is earlier.		
<b>Safety pressure relief valve</b>	8psi 0.5Atm	8psi 0.5Atm	8psi 0.5Atm
<b>Atmospheric pressure range</b>	Vacuum to 2 atmospheres		
<b>Charging, per 6V battery at 25°C</b>			
Constant voltage (cyclic)	7.35 to 7.50	7.35 to 7.50	7.35 to 7.50
Constant voltage (float)	6.81 to 7.05	6.81 to 7.05	6.81 to 7.05
N.B. No current limit is required when using a voltage regulated charger. Constant Current charging - please contact DMS for specific data.			
<b>Life expectancy (to 80% of rated capacity)</b>			
Cycle Life, 100% DOD, C/5	300*	300*	300*
Float life at 20°C, based on accelerated test methods, 6.8 volts constant voltage charge at 20°C ambient temperature	10 years	10 years	10 years
<b>Mounting</b>	Each monobloc is equipped with 0.216 in./5.49mm. mounting holes in the cover. The tightening torque for mounting the monobloc is 25in-lbs. When using 4 mounting bolts, small spacers (washers) 1 to 3mm. thick should be placed between the battery and the mounting surface to prevent bowing or stressing the battery case.		
<b>UL Recognised component. Meets UL 924</b>			

\*300 cycles at 100% depth of discharge; one cycle per, C/5 (Charge: 7.50V constant voltage, 3C current limit; 16 hour charge).

## D Monobloc

Length in/mm	4.45	113
Width in/mm	1.79	45
Height in/mm	2.75	70
Weight lbs/kg	1.15	.52
Tabs in/mm	0.187x.025	4.75x0.64

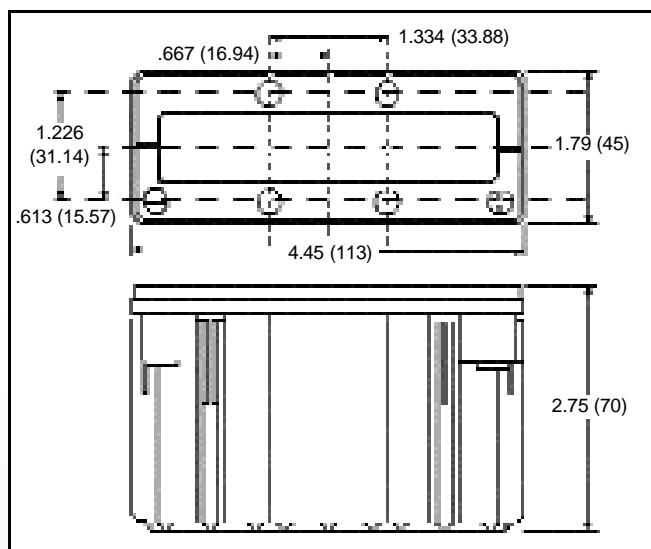

## X Monobloc

Length in/mm	5.47	139
Width in/mm	2.11	54
Height in/mm	3.02	77
Weight lbs/kg	2.16	.98
Tabs in/mm	0.250x.025	6.35x0.64

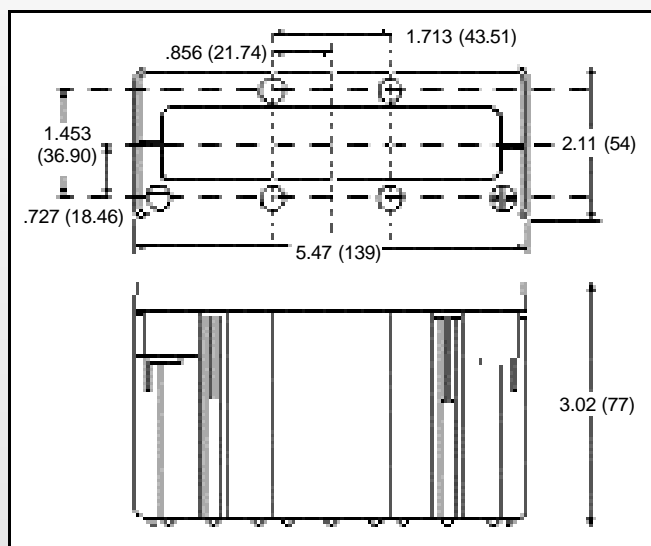

## E Monobloc

Length in/mm	5.47	139
Width in/mm	2.11	54
Height in/mm	4.00	102
Weight lbs/kg	3.15	1.43
Tabs in/mm	0.250x.025	6.35x0.64

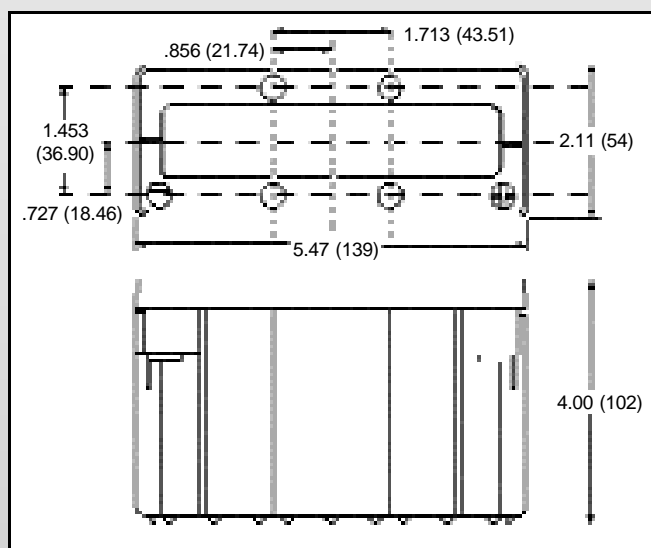

All dimensions = ins (mm).

## Monobloc Configurations

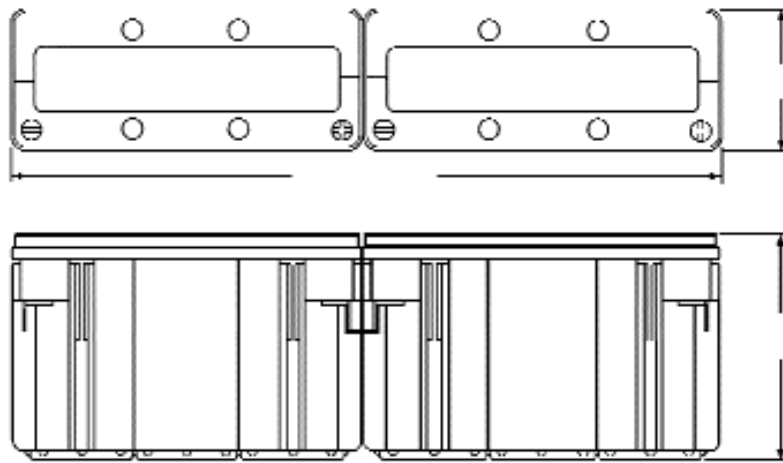

**12V 1x6 and 2x3 Monobloc configurations**

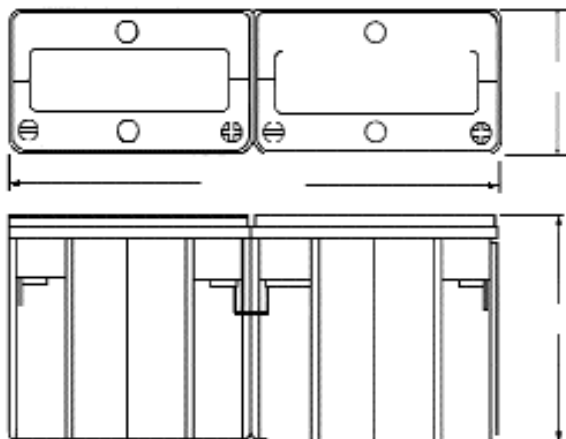
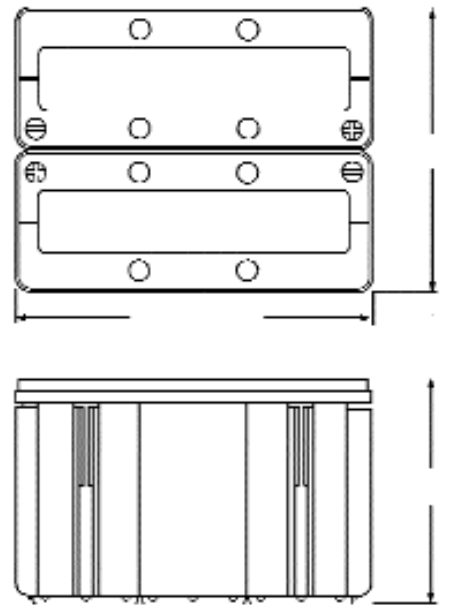

**8V 1x4 and 2x2 Monobloc configurations**

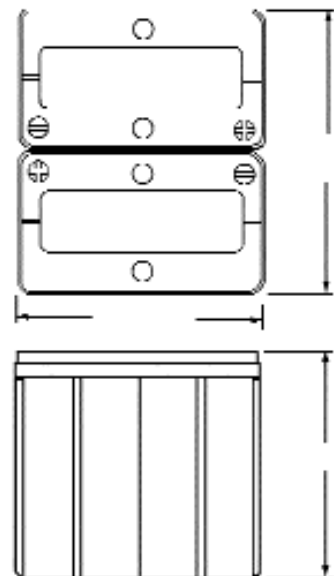

# DMS technologies

We have acquired considerable expertise in the design and development of battery and power systems tailored to customer's specific requirements. We have invested in state of the art three dimensional solid modelling CAD system. Data and designs can be transmitted electronically, reducing product development time and permitting close integration with your systems.

All design and development is carried out on a strictly confidential basis.

Enclosures can be designed and manufactured, using injection moulding, vacuum forming and sheet metal fabrication techniques.

We can provide for extreme environmental conditions and hazardous applications. Electrical and Electronics design will meet international requirements for CE marking or can be tailored to meet military or other quality standards you may require.



Our expertise extends across many industries from railways, telecommunications, special automotive projects and medical equipment to defence and military applications all over the world.

Our technical sales support department is there to help you solve your power system needs.

Call them on +44 (0)1794 830111.

**DMS technologies**  
**Belbins Business Park,**  
**Cupernham Lane,**  
**Romsey, Hampshire, SO51 7JF**  
**Telephone +44 (0) 1794 830111**  
**Fax +44 (0) 1794 830103**  
**E-mail [info@dmstech.co.uk](mailto:info@dmstech.co.uk)**  
**Web site [dmstech.co.uk](http://dmstech.co.uk)**



Cyclon cells are manufactured by Hawker Energy Products.  
Cyclon is a registered trade mark of Hawker Energy Products Inc.



## **X-ON Electronics**

Largest Supplier of Electrical and Electronic Components

*Click to view similar products for [enersys](#) manufacturer:*

Other Similar products are found below :

[SBS30](#) [SBS40](#) [0859-0012](#) [0859-0020](#) [0809-0012](#) [0820-0004](#) [0859-0010](#) [0819-0012](#) [0850-0004](#) [0800-0004](#)