



Film Capacitors

Double Sided Metallized Polypropylene Film Capacitor MMKP

Series/Type: B32641B ... B32643B

Date: June 2018

© EPCOS AG 2018. Reproduction, publication and dissemination of this publication, enclosures hereto and the information contained therein without EPCOS' prior express consent is prohibited.

EPCOS AG is a TDK Group Company.

High frequency
Typical applications

- Electronic ballasts (resonant circuits)
- LLC typology in resonant circuits
- High frequency applications with high current stress
- Switched-mode power supply

Climatic

- Max. operating temperature: 110 °C
- Climatic category (IEC 60068-1:2013): 55/110/56

Construction

- Dielectric: polypropylene (PP) with polyester (PET)
- Wound capacitor technology
- Plastic case (UL 94 V-0)
- Epoxy resin sealing

Features

- Very compact design
- High pulse strength
- High current withstand capability
- Halogen free available on request
- AEC-Q200D compliant

Terminals

- Parallel wire leads, lead-free tinned
- Special lead lengths available on request

Marking

Manufacturer's logo,
lot number, series number
rated capacitance (coded),
capacitance tolerance (code letter), rated DC voltage,
date of manufacture (coded)

Delivery mode

Bulk (untaped)

Taped (Ammo pack or reel)

For notes on taping, refer to chapter "Taping and packing".

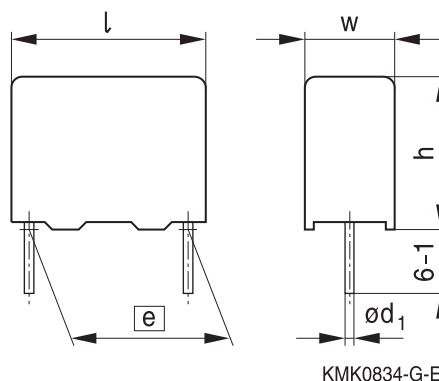
Dimensional drawing

Dimensions in mm

Lead spacing	Lead diameter	Type
$e \pm 0.4$	$d_1 \pm 0.05$	
10	0.6	B32641B
15	0.8	B32642B
22.5	0.8	B32643B



Overview of available types

Lead spacing	10 mm				15 mm					22.5 mm				
Type	B32641B				B32642B					B32643B				
Page	4				6					9				
V _R (V DC)	400	630	1000	1600	400	630	1000	1600	2000	400	630	1000	1600	2000
V _{RMS} (V AC)	250	400	500	500	250	400	500	500	500	250	400	500	500	500
C _R (nF)														
2.2														
3.3														
3.9														
4.7														
5.6														
6.8														
8.2														
10														
12														
15														
18														
22														
27														
33														
39														
47														
56														
68														
82														
100														
120														
150														
220														
330														
390														
470														
560														

B32641B
High frequency
Ordering codes and packing units (lead spacing 10 mm)

V_R	V_{RMS} $f \leq 1$ kHz	C_R	Max. dimensions $w \times h \times l$ mm	Ordering code (composition see below)	Ammo pack pcs./MOQ	Reel pcs./MOQ	Untaped pcs./MOQ
V DC	V AC	nF					
400	250	15	4.0 × 9.0 × 13.0	B32641B4153+***	4000	6800	4000
		18	4.0 × 9.0 × 13.0	B32641B4183+***	4000	6800	4000
		22	4.0 × 9.0 × 13.0	B32641B4223+***	4000	6800	4000
		27	4.0 × 9.0 × 13.0	B32641B4273+***	4000	6800	4000
		33	5.0 × 11.0 × 13.0	B32641B4333+***	3320	5200	4000
		39	5.0 × 11.0 × 13.0	B32641B4393+***	3320	5200	4000
		47	5.0 × 11.0 × 13.0	B32641B4473+***	3320	5200	4000
		56	6.0 × 12.0 × 13.0	B32641B4563+***	2720	4400	4000
		68	6.0 × 12.0 × 13.0	B32641B4683+***	2720	4400	4000
		82	6.0 × 14.0 × 13.0	B32641B4823+***	2720	4400	4000
		100	7.0 × 16.0 × 13.0	B32641B4104+***	—	—	4000
630	400	6.8	4.0 × 9.0 × 13.0	B32641B6682+***	4000	6800	4000
		8.2	4.0 × 9.0 × 13.0	B32641B6822+***	4000	6800	4000
		10	4.0 × 9.0 × 13.0	B32641B6103+***	4000	6800	4000
		12	5.0 × 11.0 × 13.0	B32641B6123+***	3320	5200	4000
		15	5.0 × 11.0 × 13.0	B32641B6153+***	3320	5200	4000
		18	5.0 × 11.0 × 13.0	B32641B6183+***	3320	5200	4000
		22	6.0 × 12.0 × 13.0	B32641B6223+***	2720	4400	4000
		27	6.0 × 12.0 × 13.0	B32641B6273+***	2720	4400	4000
		33	6.0 × 14.0 × 13.0	B32641B6333+***	2720	4400	4000
		39	7.0 × 16.0 × 13.0	B32641B6393+***	—	—	4000
		47	8.0 × 17.5 × 13.0	B32641B6473+***	—	—	2000

MOQ = Minimum Order Quantity, consisting of 4 packing units.

Further E series and intermediate capacitance values on request.

Composition of ordering code

+ = Capacitance tolerance code:

K = ±10%

J = ±5%

*** = Packaging code:

289 = Ammo pack

189 = Reel

000 = Untaped (lead length 6 – 1 mm)

Ordering codes and packing units (lead spacing 10 mm)

V_R	V_{RMS} $f \leq 1$ kHz	C_R	Max. dimensions $w \times h \times l$ mm	Ordering code (composition see below)	Ammo pack pcs./MOQ	Reel pcs./MOQ	Untaped pcs./MOQ
V DC	V AC	nF					
1000	500	4.7	4.0 × 9.0 × 13.0	B32641B0472+***	4000	6800	4000
		5.6	4.0 × 9.0 × 13.0	B32641B0562+***	4000	6800	4000
		6.8	4.0 × 9.0 × 13.0	B32641B0682+***	4000	6800	4000
		8.2	5.0 × 11.0 × 13.0	B32641B0822+***	3320	5200	4000
		10	5.0 × 11.0 × 13.0	B32641B0103+***	3320	5200	4000
		12	5.0 × 11.0 × 13.0	B32641B0123+***	3320	5200	4000
		15	6.0 × 12.0 × 13.0	B32641B0153+***	2720	4400	4000
		18	6.0 × 14.0 × 13.0	B32641B0183+***	2720	4400	4000
		22	7.0 × 16.0 × 13.0	B32641B0223+***	—	—	4000
		27	8.0 × 17.5 × 13.0	B32641B0273+***	—	—	2000
1600	500	33	8.0 × 17.5 × 13.0	B32641B0333+***	—	—	2000
		2.2	4.0 × 9.0 × 13.0	B32641B1222+***	4000	6800	4000
		3.3	4.0 × 9.0 × 13.0	B32641B1332+***	4000	6800	4000
		3.9	5.0 × 11.0 × 13.0	B32641B1392+***	3320	5200	4000
		4.7	5.0 × 11.0 × 13.0	B32641B1472+***	3320	5200	4000
		5.6	6.0 × 12.0 × 13.0	B32641B1562+***	2720	4400	4000
		6.8	6.0 × 12.0 × 13.0	B32641B1682+***	2720	4400	4000
		8.2	6.0 × 12.0 × 13.0	B32641B1822+***	2720	4400	4000
		10	6.0 × 14.0 × 13.0	B32641B1103+***	2720	4400	4000
		12	7.0 × 16.0 × 13.0	B32641B1123+***	—	—	4000
15	7.0 × 16.0 × 13.0	B32641B1153+***	—	—	4000		
18	8.0 × 17.5 × 13.0	B32641B1183+***	—	—	2000		

MOQ = Minimum Order Quantity, consisting of 4 packing units.

Further E series and intermediate capacitance values on request.

Composition of ordering code

+ = Capacitance tolerance code:

K = ±10%

J = ±5%

*** = Packaging code:

289 = Ammo pack

189 = Reel

000 = Untaped (lead length 6 – 1 mm)

B32642B
High frequency
Ordering codes and packing units (lead spacing 15 mm)

V_R	V_{RMS} $f \leq 1$ kHz	C_R	Max. dimensions $w \times h \times l$ mm	Ordering code (composition see below)	Ammo pack pcs./MOQ	Reel pcs./MOQ	Untaped pcs./MOQ
V DC	V AC	nF					
400	250	33	5.0 × 10.5 × 18.0	B32642B4333+***	4680	5200	4000
		39	5.0 × 10.5 × 18.0	B32642B4393+***	4680	5200	4000
		47	5.0 × 10.5 × 18.0	B32642B4473+***	4680	5200	4000
		56	5.0 × 10.5 × 18.0	B32642B4563+***	4680	5200	4000
		68	5.0 × 10.5 × 18.0	B32642B4683+***	4680	5200	4000
		82	6.0 × 11.0 × 18.0	B32642B4823+***	3840	4400	4000
		100	6.0 × 12.0 × 18.0	B32642B4104+***	3840	4400	4000
		120	7.0 × 12.5 × 18.0	B32642B4124+***	3320	3600	4000
		150	8.0 × 14.0 × 18.0	B32642B4154+***	2920	3000	2000
		220	9.0 × 17.5 × 18.0	B32642B4224+***	2560	2800	2000
		330	11.0 × 18.5 × 18.0	B32642B4334+***	—	2200	1200
390	11.0 × 18.5 × 18.0	B32642B4394+***	—	2200	1200		
630	400	15	5.0 × 10.5 × 18.0	B32642B6153+***	4680	5200	4000
		18	5.0 × 10.5 × 18.0	B32642B6183+***	4680	5200	4000
		22	5.0 × 10.5 × 18.0	B32642B6223+***	4680	5200	4000
		27	5.0 × 10.5 × 18.0	B32642B6273+***	4680	5200	4000
		33	5.0 × 10.5 × 18.0	B32642B6333+***	4680	5200	4000
		39	6.0 × 11.0 × 18.0	B32642B6393+***	3840	4400	4000
		47	6.0 × 12.0 × 18.0	B32642B6473+***	3840	4400	4000
		56	7.0 × 12.5 × 18.0	B32642B6563+***	3320	3600	4000
		68	8.0 × 14.0 × 18.0	B32642B6683+***	2920	3000	2000
		82	8.5 × 14.5 × 18.0	B32642B6823+***	2720	2800	2000
		100	8.5 × 14.5 × 18.0	B32642B6104+***	2720	2800	2000
		120	9.0 × 17.5 × 18.0	B32642B6124+***	2560	2800	2000
		150	11.0 × 18.5 × 18.0	B32642B6154+***	—	2200	1200

MOQ = Minimum Order Quantity, consisting of 4 packing units.
Further E series and intermediate capacitance values on request.

Composition of ordering code

+ = Capacitance tolerance code:

K = ±10%

J = ±5%

*** = Packaging code:

289 = Ammo pack

189 = Reel

000 = Untaped (lead length 6 – 1 mm)

Ordering codes and packing units (lead spacing 15 mm)

V_R	V_{RMS} $f \leq 1$ kHz	C_R	Max. dimensions $w \times h \times l$ mm	Ordering code (composition see below)	Ammo pack pcs./MOQ	Reel pcs./MOQ	Untaped pcs./MOQ
V DC	V AC	nF					
1000	500	10	5.0 × 10.5 × 18.0	B32642B0103+***	4680	5200	4000
		12	5.0 × 10.5 × 18.0	B32642B0123+***	4680	5200	4000
		15	5.0 × 10.5 × 18.0	B32642B0153+***	4680	5200	4000
		18	6.0 × 11.0 × 18.0	B32642B0183+***	3840	4400	4000
		22	6.0 × 11.0 × 18.0	B32642B0223+***	3840	4400	4000
		27	6.0 × 12.0 × 18.0	B32642B0273+***	3840	4400	4000
		33	7.0 × 12.5 × 18.0	B32642B0333+***	3320	3600	4000
		39	8.0 × 14.0 × 18.0	B32642B0393+***	2920	3000	2000
		47	8.5 × 14.5 × 18.0	B32642B0473+***	2720	3000	2800
		56	8.5 × 14.5 × 18.0	B32642B0563+***	2720	2800	2000
		68	9.0 × 17.5 × 18.0	B32642B0683+***	2560	2800	2000
		82	11.0 × 18.5 × 18.0	B32642B0823+***	—	2200	1200
		100	11.0 × 18.5 × 18.0	B32642B0104K***	—	2200	1200
1600	500	4.7	5.0 × 10.5 × 18.0	B32642B1472+***	4680	5200	4000
		5.6	5.0 × 10.5 × 18.0	B32642B1562+***	4680	5200	4000
		6.8	5.0 × 10.5 × 18.0	B32642B1682+***	4680	5200	4000
		8.2	5.0 × 10.5 × 18.0	B32642B1822+***	4680	5200	4000
		10	5.0 × 10.5 × 18.0	B32642B1103+***	4680	5200	4000
		12	6.0 × 11.0 × 18.0	B32642B1123+***	3840	4400	4000
		15	6.0 × 11.0 × 18.0	B32642B1153+***	3840	4400	4000
		18	6.0 × 12.0 × 18.0	B32642B1183+***	3840	4400	4000
		22	7.0 × 12.5 × 18.0	B32642B1223+***	3320	3600	4000
		27	8.0 × 14.0 × 18.0	B32642B1273+***	2920	3000	2000
		33	8.5 × 14.5 × 18.0	B32642B1333+***	2720	2800	2000
		39	9.0 × 17.5 × 18.0	B32642B1393+***	2560	2800	2000
		47	9.0 × 17.5 × 18.0	B32642B1473+***	2560	2800	2000
		56	11.0 × 18.5 × 18.0	B32642B1563+***	—	2200	1200

MOQ = Minimum Order Quantity, consisting of 4 packing units.
Further E series and intermediate capacitance values on request.

Composition of ordering code

+ = Capacitance tolerance code:

K = ±10%

J = ±5%

*** = Packaging code:

289 = Ammo pack

189 = Reel

000 = Untaped (lead length 6 – 1 mm)



B32642B

High frequency

Ordering codes and packing units (lead spacing 15 mm)

V_R	V_{RMS} $f \leq 1$ kHz	C_R	Max. dimensions $w \times h \times l$ mm	Ordering code (composition see below)	Ammo pack pcs./MOQ	Reel pcs./MOQ	Untaped pcs./MOQ
V DC	V AC	nF					
2000	500	3.3	5.0 × 10.5 × 18.0	B32642B8332+***	4680	5200	4000
		3.9	5.0 × 10.5 × 18.0	B32642B8392+***	4680	5200	4000
		4.7	5.0 × 10.5 × 18.0	B32642B8472+***	4680	5200	4000
		5.6	6.0 × 11.0 × 18.0	B32642B8562+***	3840	4400	4000
		6.8	6.0 × 11.0 × 18.0	B32642B8682+***	3840	4400	4000
		8.2	7.0 × 12.5 × 18.0	B32642B8822+***	3320	3600	4000
		10	7.0 × 12.5 × 18.0	B32642B8103+***	3320	3600	4000
		12	8.0 × 14.0 × 18.0	B32642B8123+***	2920	3000	2000
		15	8.5 × 14.5 × 18.0	B32642B8153+***	2720	2800	2000
		18	9.0 × 17.5 × 18.0	B32642B8183+***	2560	2800	2000
		22	9.0 × 17.5 × 18.0	B32642B8223+***	2560	2800	2000
		27	11.0 × 18.5 × 18.0	B32642B8273+***	—	2200	1200

MOQ = Minimum Order Quantity, consisting of 4 packing units.
Further E series and intermediate capacitance values on request.

Composition of ordering code

+ = Capacitance tolerance code:

K = ±10%

J = ±5%

*** = Packaging code:

289 = Ammo pack

189 = Reel

000 = Untaped (lead length 6 – 1 mm)

Ordering codes and packing units (lead spacing 22.5 mm)

V_R	V_{RMS} $f \leq 1$ kHz	C_R	Max. dimensions $w \times h \times l$ mm	Ordering code (composition see below)	Ammo pack pcs./MOQ	Reel pcs./MOQ	Untaped pcs./MOQ
V DC	V AC	nF					
400	250	120	6.0 × 15.0 × 26.5	B32643B4124+***	2720	2800	2880
		150	6.0 × 15.0 × 26.5	B32643B4154+***	2720	2800	2880
		220	7.0 × 16.0 × 26.5	B32643B4224+***	2320	2400	2520
		330	8.5 × 16.5 × 26.5	B32643B4334+***	1920	2000	2040
		390	8.5 × 16.5 × 26.5	B32643B4394+***	1920	2000	2040
		470	10.5 × 18.5 × 26.5	B32643B4474+***	1560	1600	2160
		560	10.5 × 18.5 × 26.5	B32643B4564+***	1560	1600	2160
630	400	68	6.0 × 15.0 × 26.5	B32643B6683+***	2720	2800	2880
		82	6.0 × 15.0 × 26.5	B32643B6823+***	2720	2800	2880
		100	6.0 × 15.0 × 26.5	B32643B6104+***	2720	2800	2880
		120	6.0 × 15.0 × 26.5	B32643B6124+***	2720	2800	2880
		150	7.0 × 16.0 × 26.5	B32643B6154+***	2320	2400	2520
		220	10.5 × 16.5 × 26.5	B32643B6224+***	1560	1600	2160
		330	11.0 × 20.5 × 26.5	B32643B6334+***	1480	1400	2040
		390	12.0 × 22.0 × 26.5	B32643B6394+***	—	—	1800
1000	500	470	14.5 × 29.5 × 26.5	B32643B6474+***	—	—	1040
		33	6.0 × 15.0 × 26.5	B32643B0333+***	2720	2800	2880
		39	6.0 × 15.0 × 26.5	B32643B0393+***	2720	2800	2880
		47	6.0 × 15.0 × 26.5	B32643B0473+***	2720	2800	2880
		56	6.0 × 15.0 × 26.5	B32643B0563+***	2720	2800	2880
		68	7.0 × 16.0 × 26.5	B32643B0683+***	2320	2400	2520
		82	7.0 × 16.0 × 26.5	B32643B0823+***	2320	2400	2520
		100	8.5 × 16.5 × 26.5	B32643B0104+***	1920	2000	2040
		120	10.5 × 16.5 × 26.5	B32643B0124+***	1560	1600	2160
		150	10.5 × 18.5 × 26.5	B32643B0154+***	1560	1600	2160
		220	12.0 × 22.0 × 26.5	B32643B0224+***	—	—	1800
		330	14.5 × 29.5 × 26.5	B32643B0334+***	—	—	1040
390	14.5 × 29.5 × 26.5	B32643B0394+***	—	—	1040		

MOQ = Minimum Order Quantity, consisting of 4 packing units.
Further E series and intermediate capacitance values on request.

Composition of ordering code

+ = Capacitance tolerance code:

K = ±10%

J = ±5%

*** = Packaging code:

289 = Ammo pack

189 = Reel

000 = Untaped (lead length 6 – 1 mm)

B32643B
High frequency
Ordering codes and packing units (lead spacing 22.5 mm)

V_R	V_{RMS} $f \leq 1$ kHz	C_R	Max. dimensions $w \times h \times l$ mm	Ordering code (composition see below)	Ammo pack pcs./MOQ	Reel pcs./MOQ	Untaped pcs./MOQ
V DC	V AC	nF					
1600	500	22	6.0 × 15.0 × 26.5	B32643B1223+***	2720	2800	2880
		27	6.0 × 15.0 × 26.5	B32643B1273+***	2720	2800	2880
		33	6.0 × 15.0 × 26.5	B32643B1333+***	2720	2800	2880
		39	7.0 × 16.0 × 26.5	B32643B1393+***	2320	2400	2520
		47	7.0 × 16.0 × 26.5	B32643B1473+***	2320	2400	2520
		56	8.5 × 16.5 × 26.5	B32643B1563+***	1920	2000	2040
		68	8.5 × 16.5 × 26.5	B32643B1683+***	1920	2000	2040
		82	10.5 × 16.5 × 26.5	B32643B1823+***	1560	1600	2160
		100	10.5 × 18.5 × 26.5	B32643B1104+***	1560	1600	2160
		120	12.0 × 22.0 × 26.5	B32643B1124+***	—	—	1800
		150	14.5 × 29.5 × 26.5	B32643B1154+***	—	—	1040
		220	14.5 × 29.5 × 26.5	B32643B1224+***	—	—	1040
2000	500	10	6.0 × 15.0 × 26.5	B32643B8103+***	2720	2800	2880
		12	6.0 × 15.0 × 26.5	B32643B8123+***	2720	2800	2880
		15	6.0 × 15.0 × 26.5	B32643B8153+***	2720	2800	2880
		18	6.0 × 15.0 × 26.5	B32643B8183+***	2720	2800	2880
		22	6.0 × 15.0 × 26.5	B32643B8223+***	2720	2800	2880
		27	7.0 × 16.0 × 26.5	B32643B8273+***	2320	2400	2520
		33	8.5 × 16.5 × 26.5	B32643B8333+***	1920	2000	2040
		39	8.5 × 16.5 × 26.5	B32643B8393+***	1920	2000	2040
		47	10.5 × 16.5 × 26.5	B32643B8473+***	1560	1600	2160
		56	10.5 × 18.5 × 26.5	B32643B8563+***	1560	1600	2160
		68	11.0 × 20.5 × 26.5	B32643B8683+***	1480	1400	2040
		82	12.0 × 22.0 × 26.5	B32643B8823+***	—	—	1800
		100	14.5 × 29.5 × 26.5	B32643B8104+***	—	—	1040
		120	14.5 × 29.5 × 26.5	B32643B8124+***	—	—	1040

MOQ = Minimum Order Quantity, consisting of 4 packing units.
Further E series and intermediate capacitance values on request.

Composition of ordering code

+ = Capacitance tolerance code:

K = ±10%

J = ±5%

*** = Packaging code:

289 = Ammo pack

189 = Reel

000 = Untaped (lead length 6 – 1 mm)

Technical data

Reference standard: IEC 60384-16:2005 and AEC-Q200D. All data given at $T = 20\text{ °C}$, unless otherwise specified.

Rated temperature T_R	+85 °C	
Operating temperature range	Max. operating temperature $T_{op,max}$ +110 °C	
	Upper category temperature T_{max} +110 °C	
	Lower category temperature T_{min} -55 °C	
	Rated temperature T_R +85 °C	
Dissipation factor $\tan \delta$ (in 10^{-3}) at 20 °C (upper limit values)	1 kHz	0.6
	10 kHz	0.6
	100 kHz	1.5
Insulation resistance R_{ins} at 20 °C, rel. humidity $\leq 65\%$ (minimum as-delivered values)	$C_R \leq 0.33\ \mu\text{F}$; 100 G Ω	
	$C_R > 0.33\ \mu\text{F}$; 30000 S	
Test voltage (terminal to terminal)	$1.6 \cdot V_R$, 2 s	
Test voltage (terminal to case)	2000 V AC, 60s	
Category voltage V_C (continuous operation with V_{DC})	T_{op} (°C)	DC voltage derating
	$T_{op} \leq 85$	$V_C = V_R$
	$85 < T_{op} \leq 110$	$V_C = V_R \cdot (165 - T_{op})/80$
Operating voltage V_{op} for short operating periods (V_{DC})	T_{op} (°C)	DC voltage (max. hours)
	$T_{op} \leq 85$	$V_{op} = 1.25 \cdot V_C$ (1000 h)
	$85 < T_{op} \leq 110$	$V_{op} = 1.25 \cdot V_C$ (1000 h)
Advanced biased humidity	1000 h / 60 °C / 95% relative humidity with $V_{R,DC}$	
Limit value after humidity test	Capacitance change $ \Delta C/C $	$\leq 5\%$
	Dissipation factor change $\Delta \tan \delta$	$\leq 1.5 \cdot$ upper limit (100 kHz)
	Insulation resistance R_{ins}	$\geq 50\%$ of minimum as-delivered values
Failure rate λ	1 fit ($\leq 1 \cdot 10^{-9}/\text{h}$) at $0.5 \cdot V_R$, 40 °C	
Service life t_{SL}	200 000 h at $1.0 \cdot V_R$, 85 °C	
	For conversion to other operating conditions and temperatures, refer to chapter "Quality, 2 Reliability".	
Failure criteria:		
Total failure	Short circuit or open circuit	
Failure due to variation of parameters	Capacitance change $ \Delta C/C $	$> 10\%$
	Dissipation factor $\tan \delta$	$> 4 \cdot$ upper limit value
	Insulation resistance R_{ins}	$< 1500\ \text{M}\Omega$



B32641B ... B32643B

High frequency

Pulse handling capability

"dV/dt" represents the maximum permissible voltage change per unit of time for non-sinusoidal voltages, expressed in V/μs.

"k₀" represents the maximum permissible pulse characteristic of the waveform applied to the capacitor, expressed in V²/μs.

Note:

The values of dV/dt and k₀ provided below must not be exceeded in order to avoid damaging the capacitor. These parameters are given for isolated pulses in such a way that the heat generated by one pulse will be completely dissipated before applying the next pulse. For a train of pulses, please refer to the curves of permissible AC voltage-current versus frequency.

dV/dt values

Lead spacing		10 mm	15 mm	22.5 mm
V _R V DC	V _{RMS} V AC	dV/dt in V/μs		
400	250	1500	900	500
630	400	4000	2700	1500
1000	500	6200	3500	2100
1600	500	8000	5300	3000
2000	500	—	6500	3800

k₀ values

Lead spacing		10 mm	15 mm	22.5 mm
V _R V DC	V _{RMS} V AC	k ₀ in V ² /μs		
400	250	1 200 000	720 000	400 000
630	400	5 040 000	3 402 000	1 890 000
1000	500	12 400 000	7 000 000	4 200 000
1600	500	25 600 000	16 960 000	9 600 000
2000	500	—	26 000 000	15 000 000

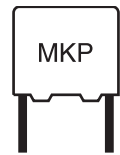

Impedance Z versus frequency f
(typical values)

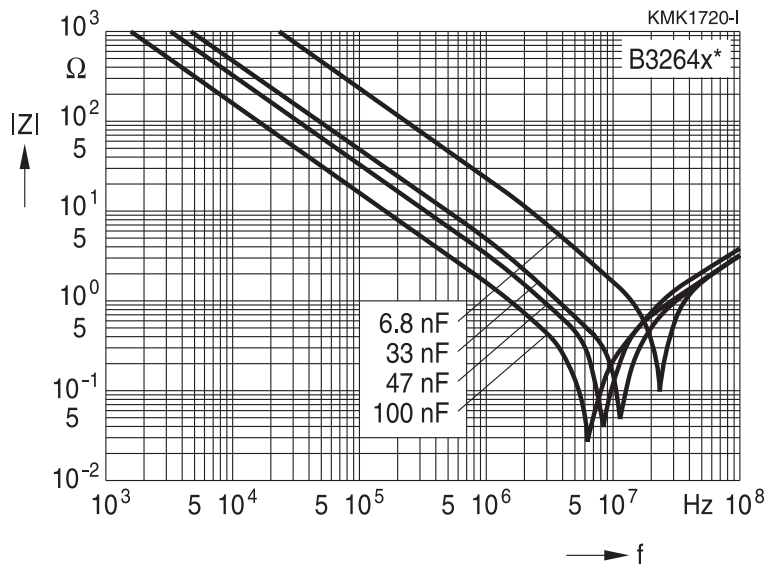



B32641B

High frequency

Permissible AC voltage V_{RMS} versus frequency f (for sinusoidal waveforms, $T_A \leq 85^\circ\text{C}$, $\Delta T \leq 15^\circ\text{C}$)

Lead spacing 10 mm

400 V DC/250 V AC

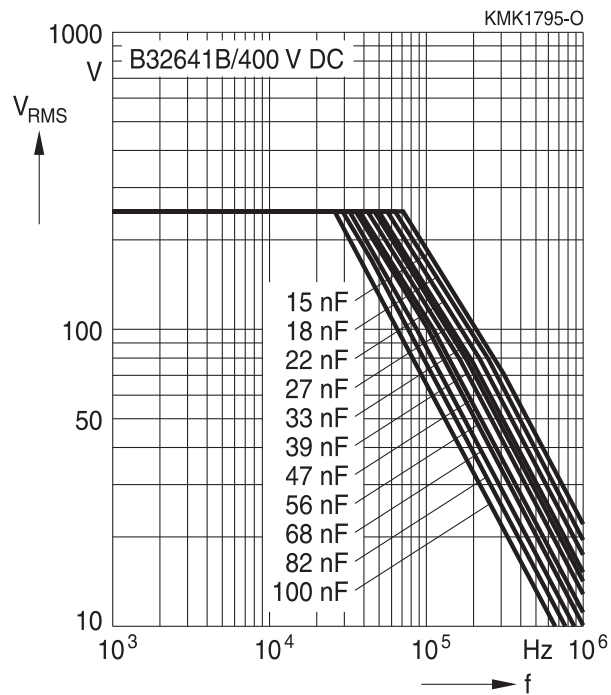

630 V DC/400 V AC

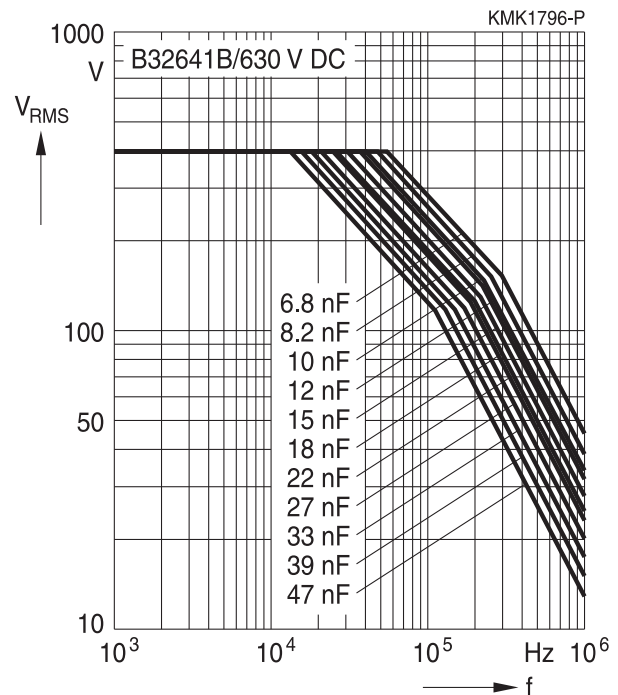

1000 V DC/500 V AC

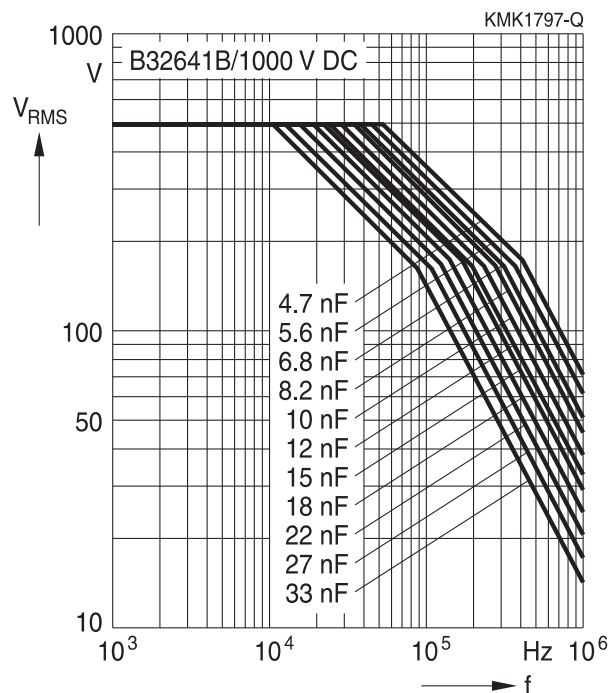

1600 V DC/500 V AC

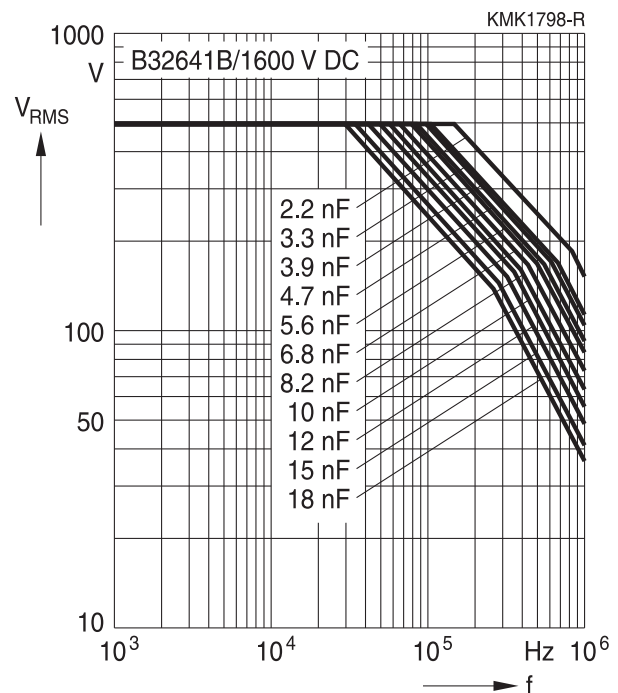

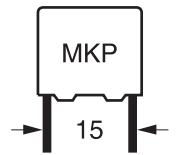

B32642B

High frequency

Permissible AC voltage V_{RMS} versus frequency f (for sinusoidal waveforms, $T_A \leq 85^\circ C$, $\Delta T \leq 15^\circ C$)

Lead spacing 15 mm

400 V DC/250 V AC

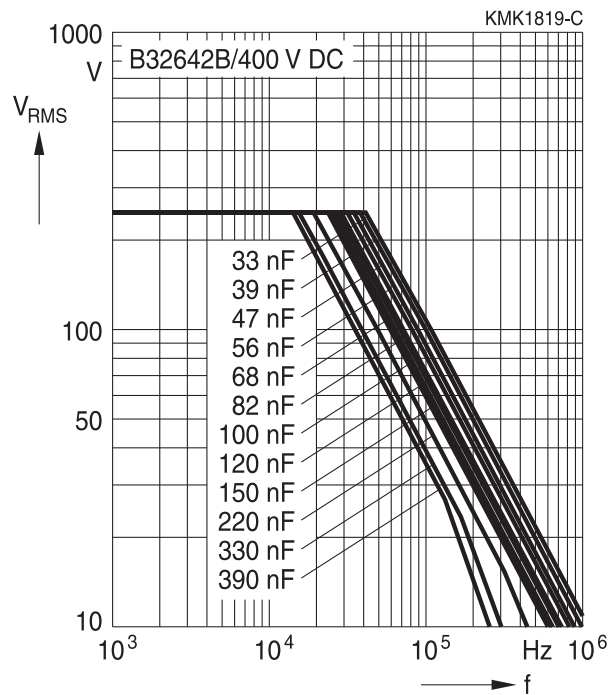

630 V DC/400 V AC

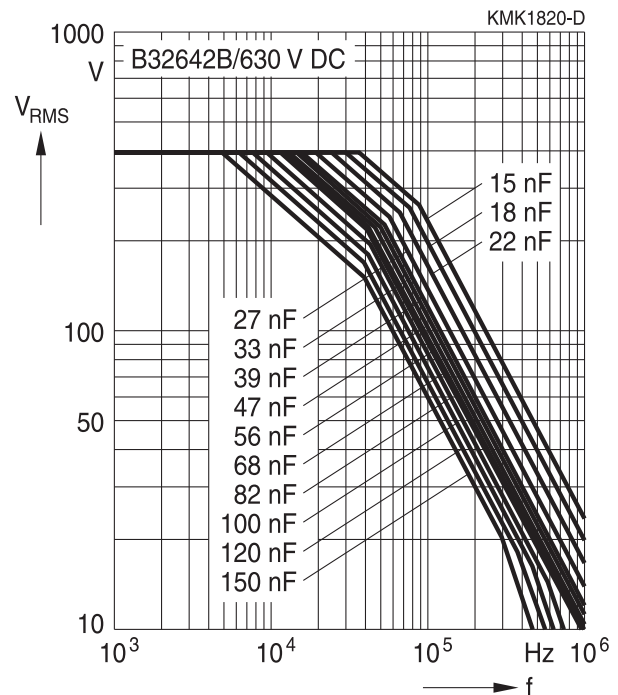

1000 V DC/500 V AC

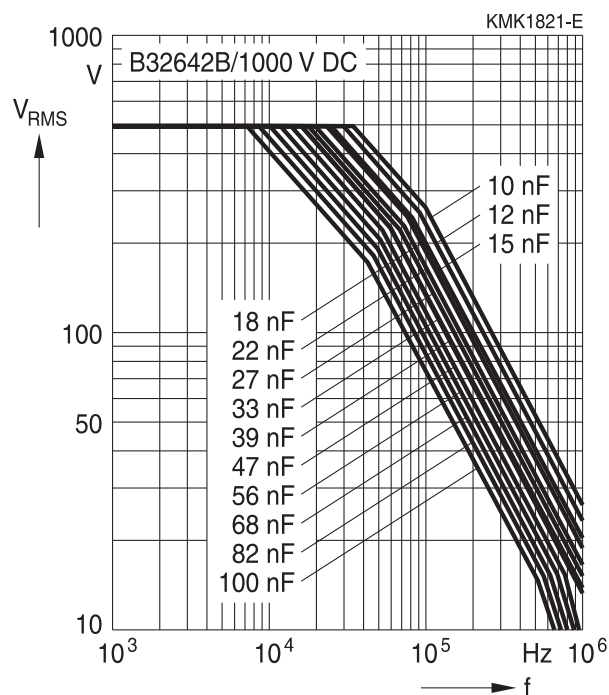

1600 V DC/500 V AC

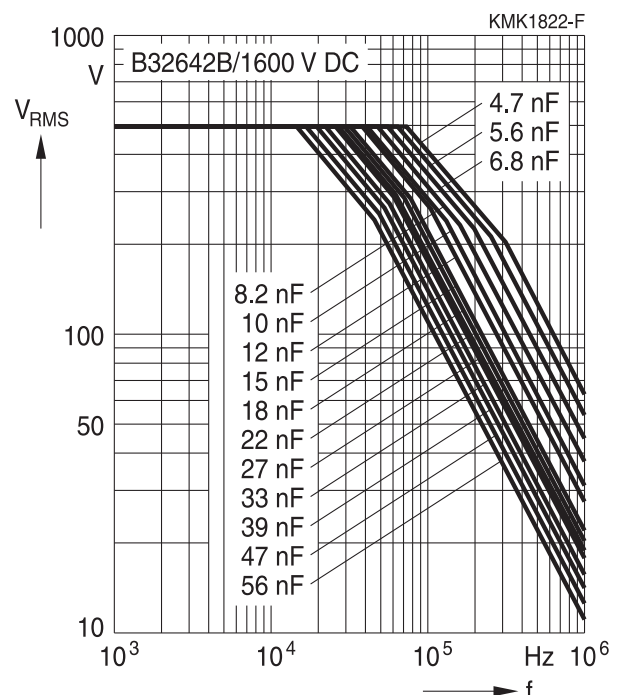

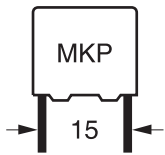

B32642B

High frequency

Permissible AC voltage V_{RMS} versus frequency f (for sinusoidal waveforms, $T_A \leq 85\text{ }^\circ\text{C}$, $\Delta T \leq 15\text{ }^\circ\text{C}$)

Lead spacing 15 mm

2000 V DC/500 V AC

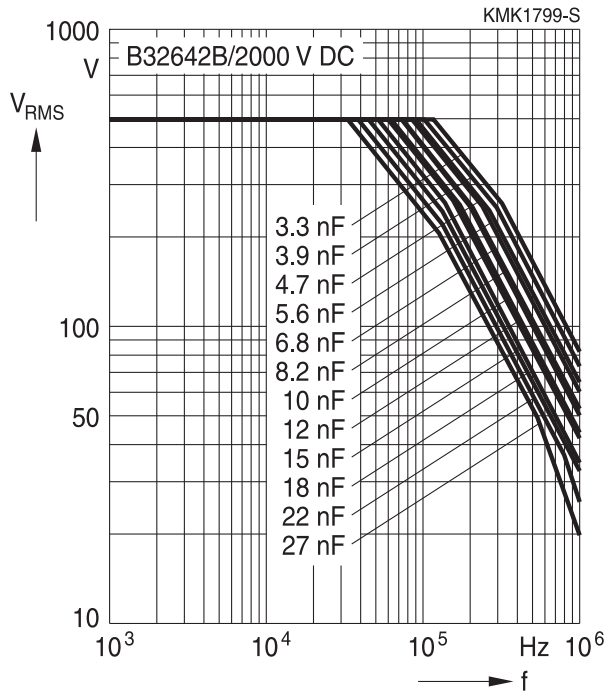

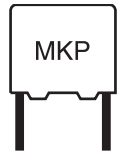

Permissible AC voltage V_{RMS} versus frequency f (for sinusoidal waveforms, $T_A \leq 85^\circ\text{C}$, $\Delta T \leq 15^\circ\text{C}$)

Lead spacing 22.5 mm

400 V DC/250 V AC

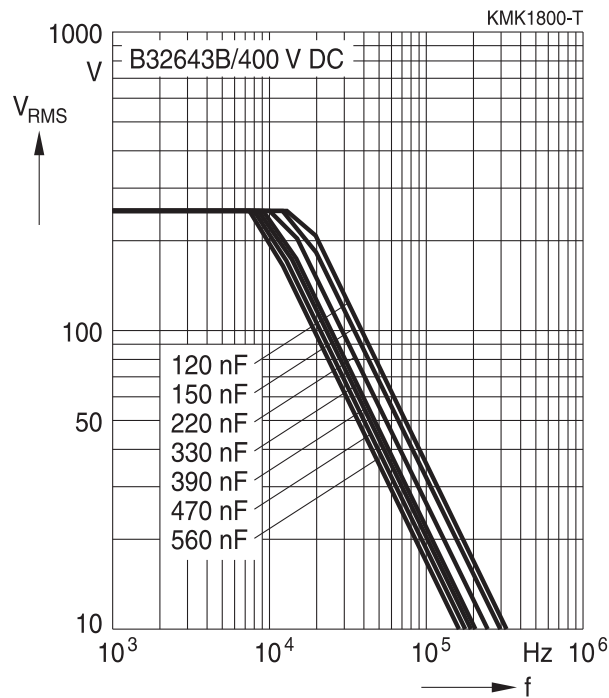

630 V DC/400 V AC

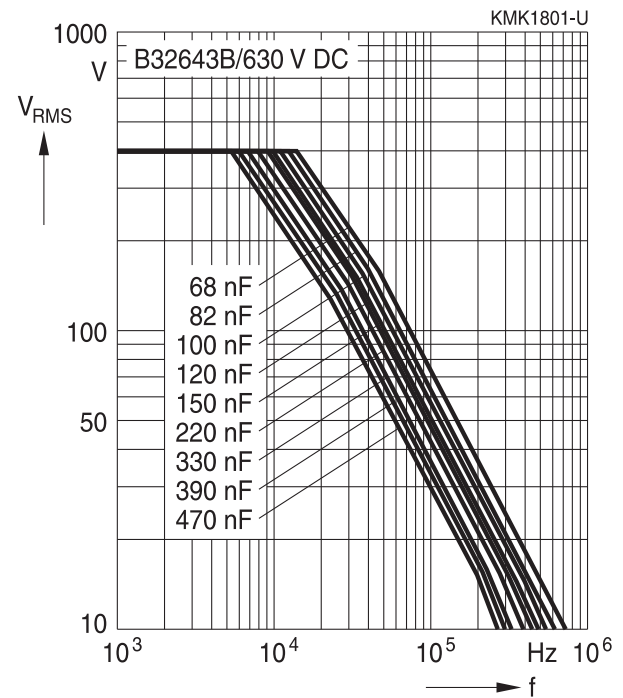

1000 V DC/500 V AC

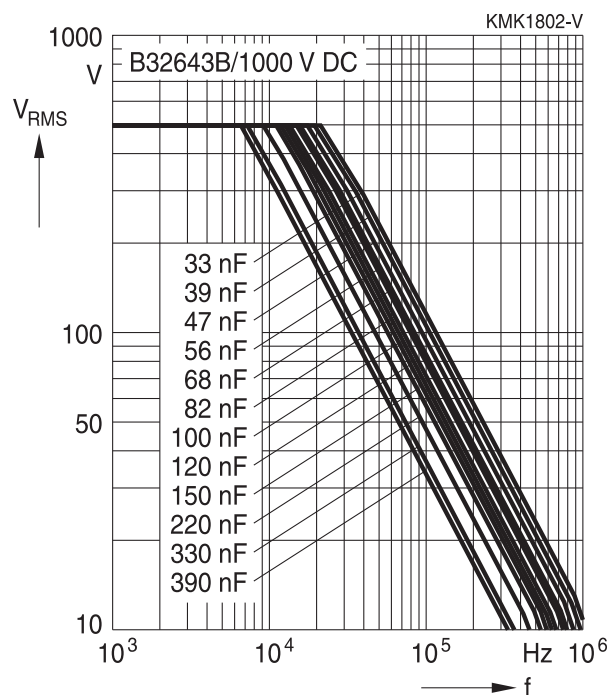

1600 V DC/500 V AC

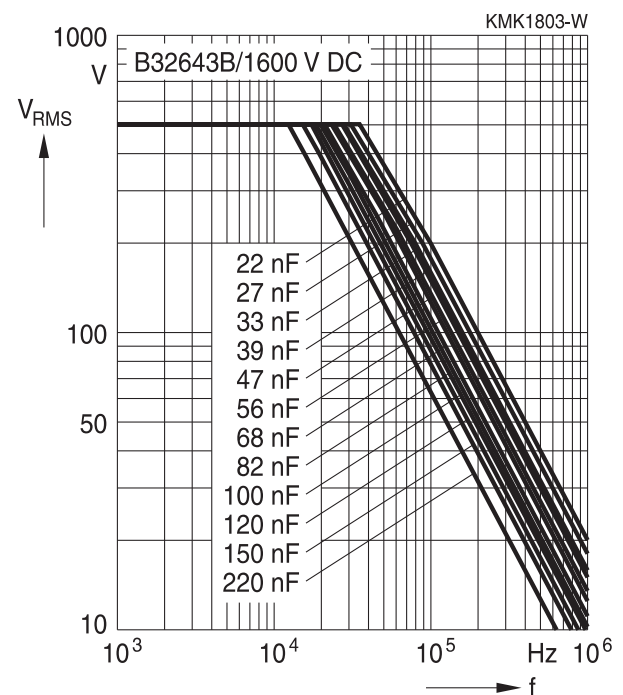

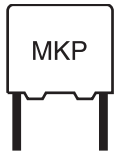

B32641B ... B32643B

High frequency

Permissible AC voltage V_{RMS} versus frequency f (for sinusoidal waveforms, $T_A \leq 85^\circ\text{C}$, $\Delta T \leq 15^\circ\text{C}$)

Lead spacing 22.5 mm

2000 V DC/500 V AC

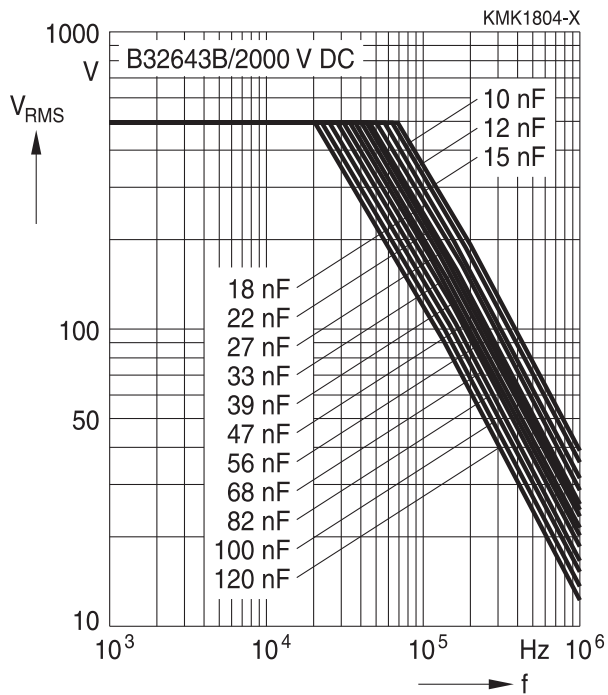

B32641B

High frequency



Permissible current I_{RMS} versus frequency f (for sinusoidal waveforms, $T_A \leq 85^\circ\text{C}$, $\Delta T \leq 15^\circ\text{C}$)

Lead spacing 10 mm

400 V DC/250 V AC

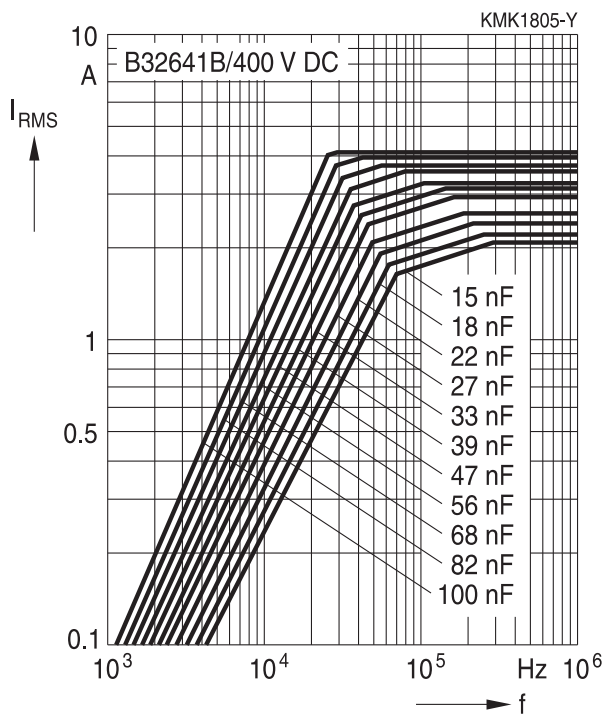

630 V DC/400 V AC

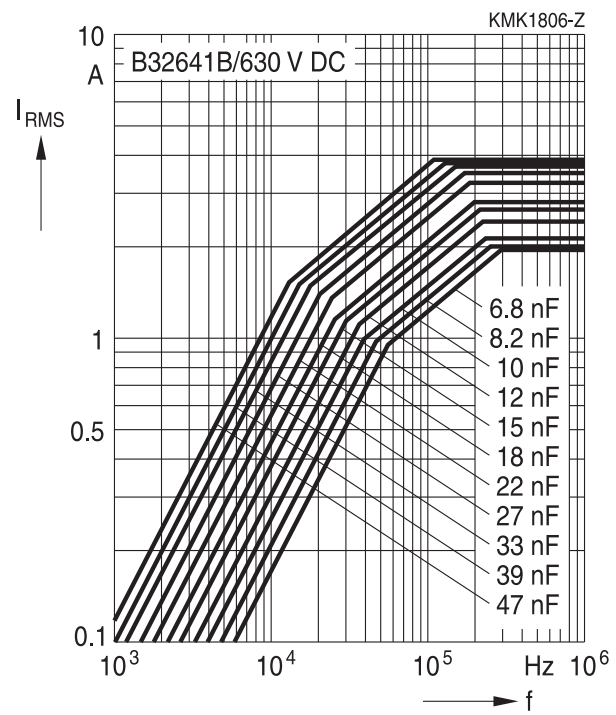

1000 V DC/500 V AC

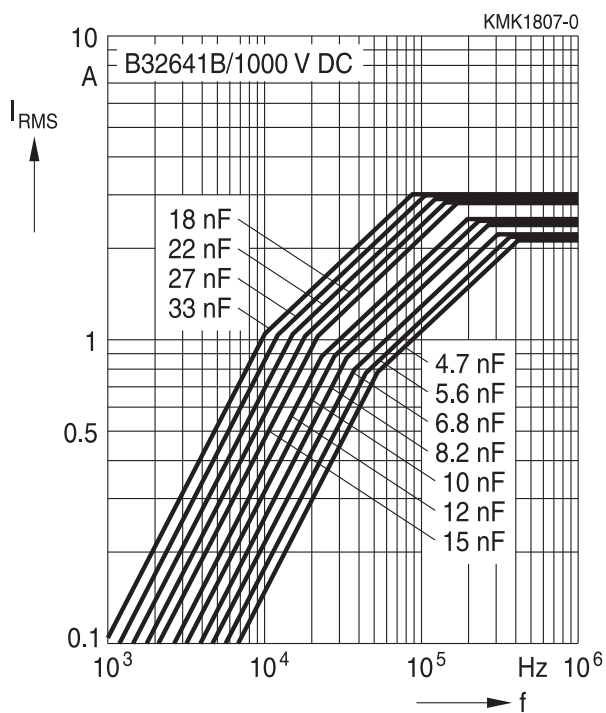

1600 V DC/500 V AC

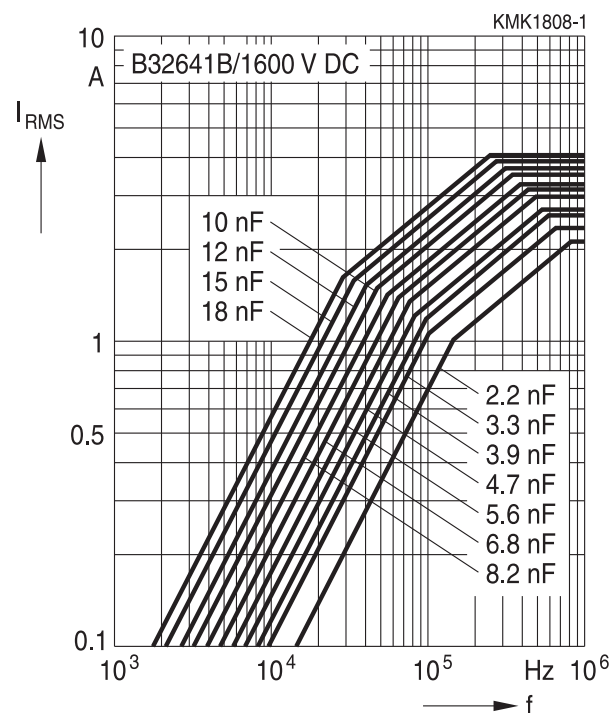

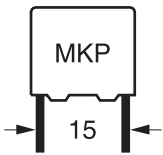

B32642B

High frequency

Permissible current I_{RMS} versus frequency f (for sinusoidal waveforms, $T_A \leq 85^\circ C$, $\Delta T \leq 15^\circ C$)

Lead spacing 15 mm

400 V DC/250 V AC

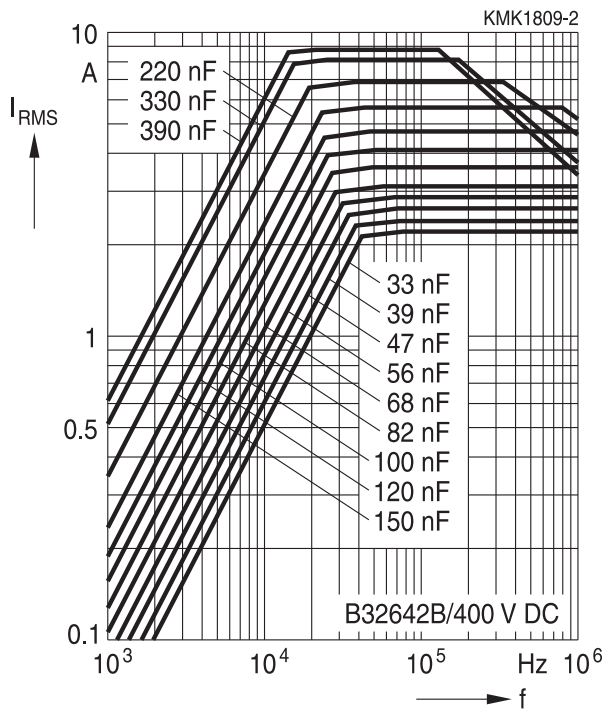

630 V DC/400 V AC

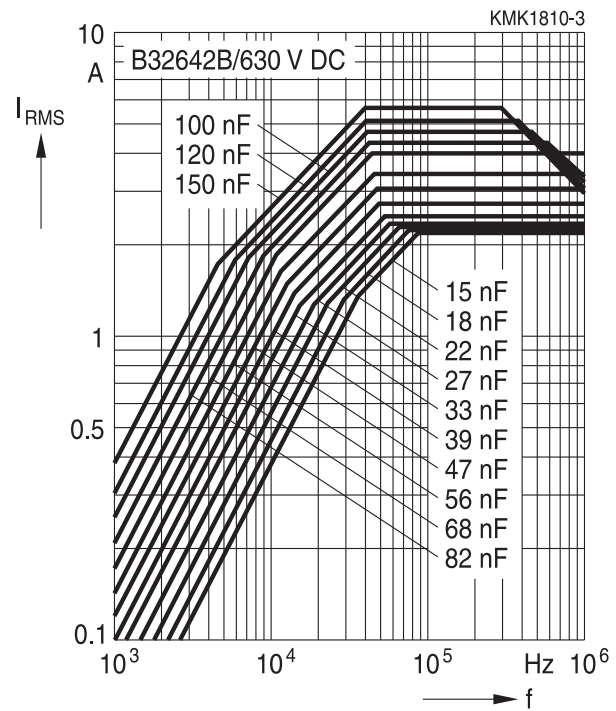

1000 V DC/500 V AC

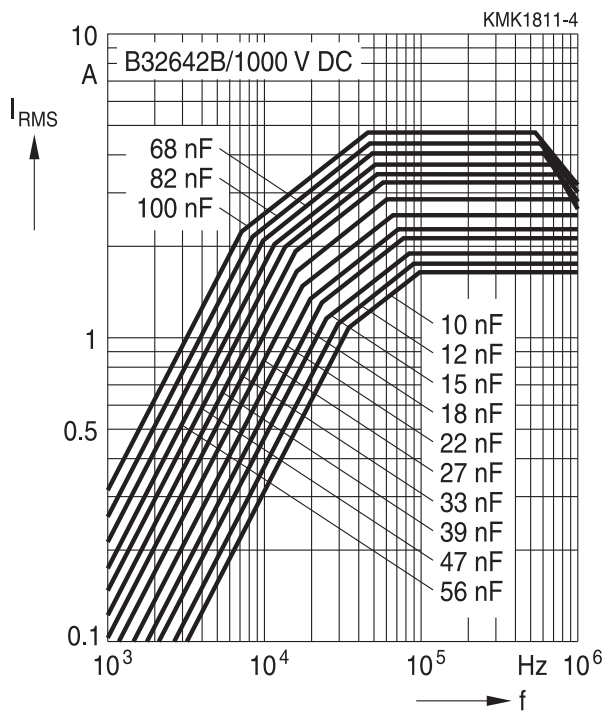

1600 V DC/500 V AC

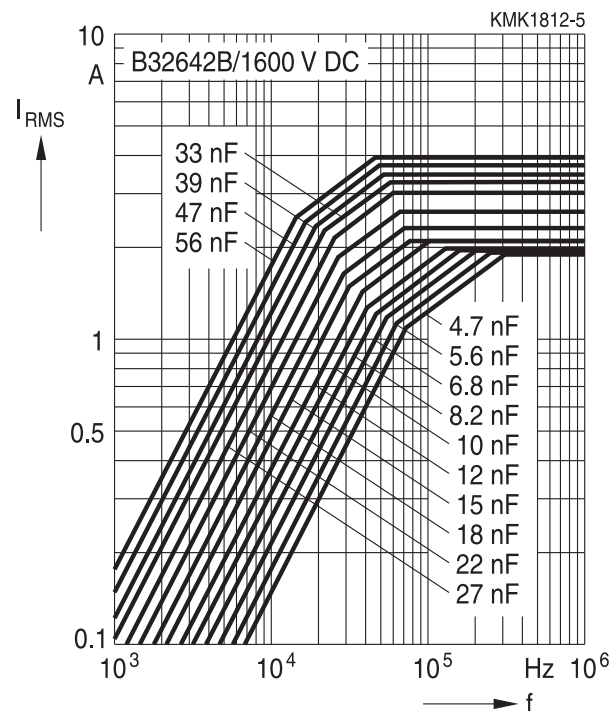

B32642B
High frequency

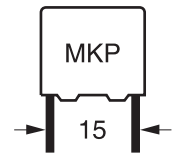

Permissible current I_{RMS} versus frequency f (for sinusoidal waveforms, $T_A \leq 85^\circ\text{C}$, $\Delta T \leq 15^\circ\text{C}$)

Lead spacing 15 mm

2000 V DC/500 V AC

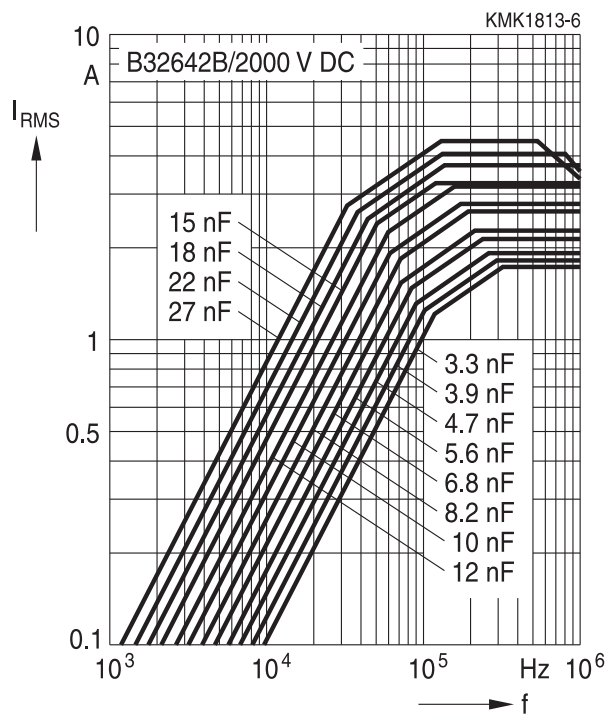

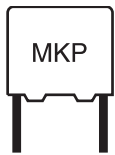

B32641B ... B32643B

High frequency

Permissible current I_{RMS} versus frequency f (for sinusoidal waveforms, $T_A \leq 85^\circ C$, $\Delta T \leq 15^\circ C$)

Lead spacing 22.5 mm

400 V DC/250 V AC

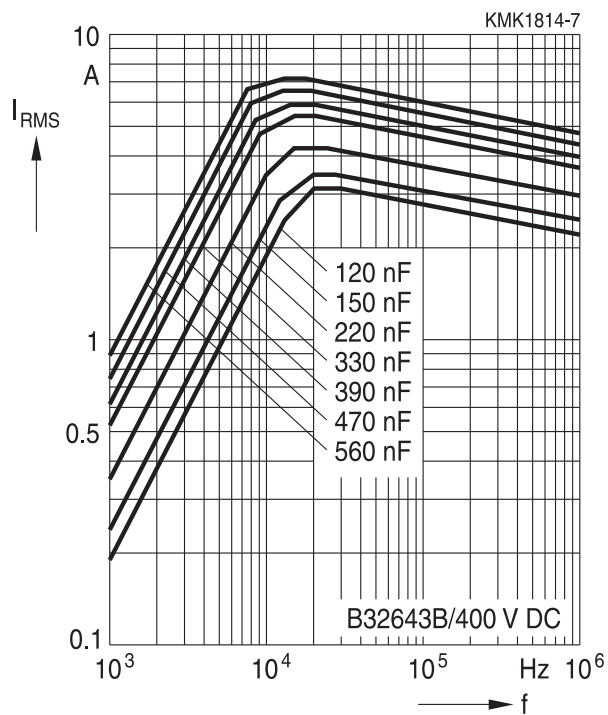

630 V DC/400 V AC

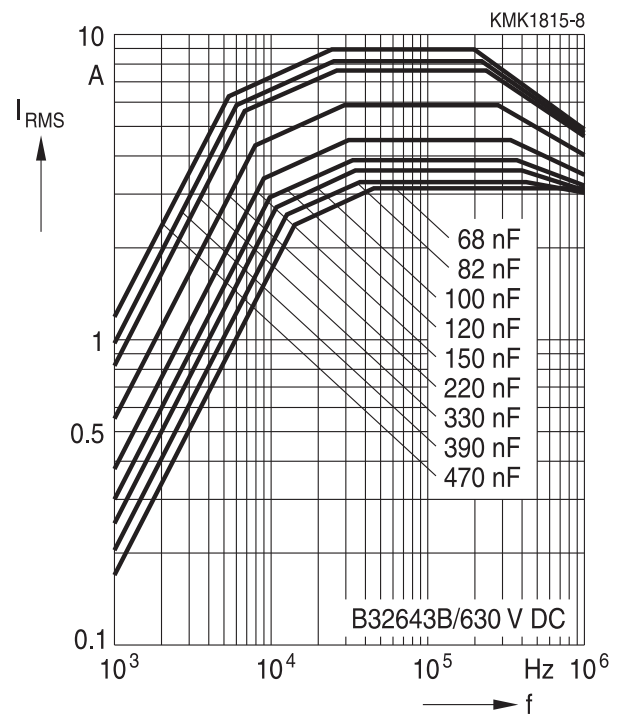

1000 V DC/500 V AC

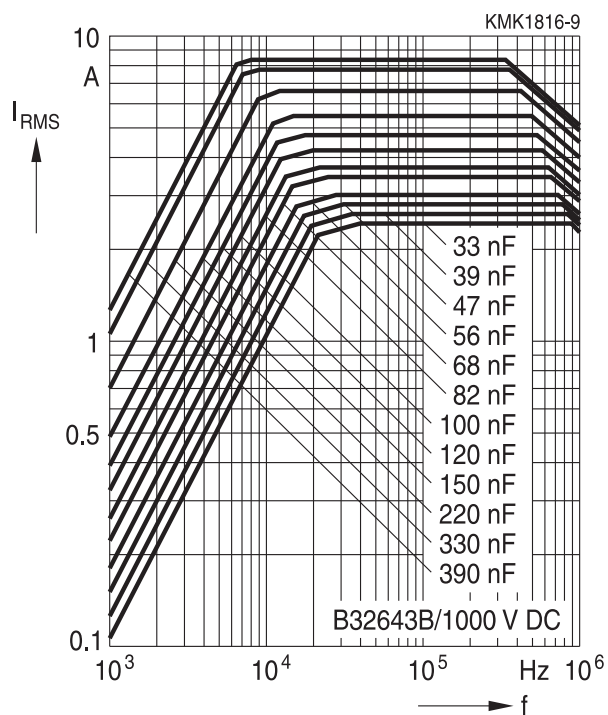

1600 V DC/500 V AC

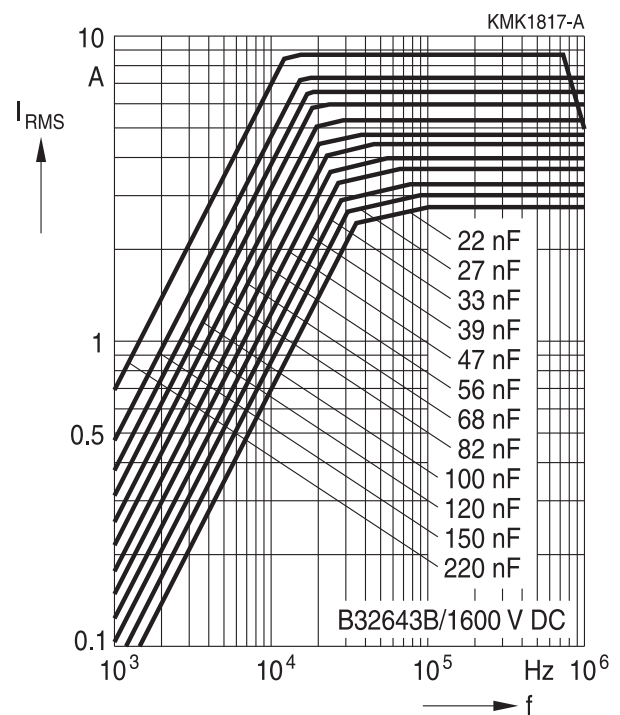

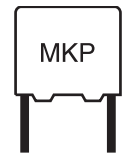

Permissible current I_{RMS} versus frequency f (for sinusoidal waveforms, $T_A \leq 85^\circ\text{C}$, $\Delta T \leq 15^\circ\text{C}$)

Lead spacing 22.5 mm

2000 V DC/500 V AC

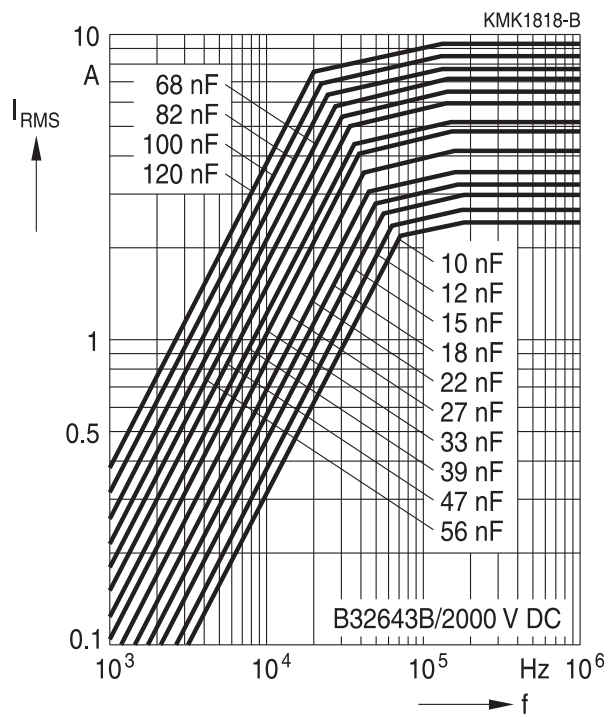



B32641B ... B32643B

High frequency

Testing and Standards

Test and IEC reference	Conditions of test	Failure criteria			
		Visible damages	$ \Delta C/C $	$\tan \delta$ (100kHz)	R_{ins}
Electrical parameters IEC 60384-16:2005	Capacitance: 1 KHz, 1.0 V Loss factor: 1 KHz, 1.0 V 100 KHz, 1.0V Voltage proof: 1.6 V_R , 1 min Insulation resistance: 500 V, 1 min	Yes		Within specified limits	<100 G Ω
Rapid change of temperature IEC 60384-16:2005	T_A = Lower category temperature T_B = Upper category temperature Five cycles, duration t = 30 min	Yes	–	–	–
Vibration IEC 60384-16:2005	10 Hz ~ 500 Hz 0.75 mm 6 hours per axe	Yes	–	–	–
Bump IEC 60384-16:2005	390 m/s ² 6 ms 3 axes, total number of bumps: 4000	Yes	> 2%	> upper limit value	< 50% of min. as-delivered value
Climatic sequence IEC 60384-1:2016	Dry heat: 16 hours Damp heat, one cycle Test Aa 2 hours	Yes	> 2%	> 1.5 × upper limit value	< 50% of min. as-delivered value
Damp heat, steady state IEC 60384-16:2005	40 °C / 93% relative humidity / 56 days	Yes	> 3%	> 1.5 × upper limit value	< 50% of min. as-delivered value
Advanced biased humidity	60 °C / 95% relative humidity with $V_{R,DC}$ / 1000 hours	Yes	> 5%	> 1.5 × upper limit value	< 50% of min. as-delivered value
Resistance to soldering heat IEC 60068-2-20:2008	Solder bath at +260 °C ±5°C	Yes	> 2%	> upper limit value	< 50% of min. as-delivered value
Endurance IEC 60384-16:2005	85 °C / 1.25 V_R / 1000 hours	Yes	> 5%	> 1.5 × upper limit value	< 50% of min. as-delivered value
Charge and discharge IEC 60384-16:2005	10000 pulses and with 2 times dV/dt according to detail specification	Yes	> 3%	> 1.5 × upper limit value	< 50% of min. as-delivered value



Construction MMKP

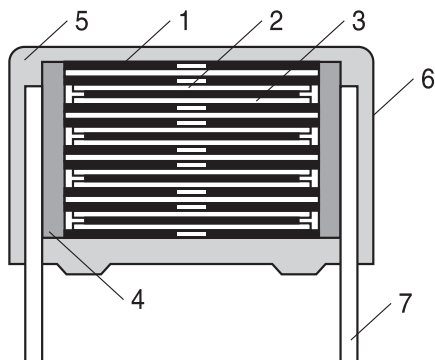

KMK1729-U

- 1 Dielectric film: Metallized polyethylene terephthalate (polyester, PET)
- 2 Dielectric film: Polypropylene (PP)
- 3 Dielectric film: Metallized polypropylene (PP)
- 4 Metal spray: Lead free alloy
- 5 Sealing: Epoxy resin sealing
- 6 Case: PBT, according to UL 94-0
- 7 Terminal: Lead free tinned wire

Important note

The operating temperature, which is the sum of ambient temperature and self-heating, shall not exceed the upper category temperature (110 °C). To assure this, a derating in the I_{RMS} shall be applied as follows:

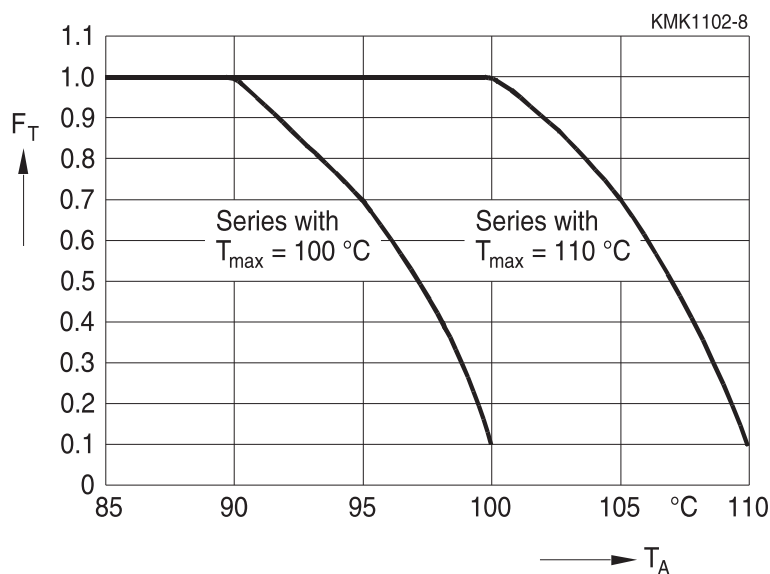



B32641B ... B32643B

High frequency

Mounting guidelines

1 Soldering

1.1 Solderability of leads

The solderability of terminal leads is tested to IEC 60068-2-20:2008, test Ta, method 1.

Before a solderability test is carried out, terminals are subjected to accelerated ageing (to IEC 60068-2-2:2007, test Ba: 4 h exposure to dry heat at 155 °C). Since the ageing temperature is far higher than the upper category temperature of the capacitors, the terminal wires should be cut off from the capacitor before the ageing procedure to prevent the solderability being impaired by the products of any capacitor decomposition that might occur.

Solder bath temperature	235 ±5 °C
Soldering time	2.0 ±0.5 s
Immersion depth	2.0 +0/−0.5 mm from capacitor body or seating plane
Evaluation criteria: Visual inspection	Wetting of wire surface by new solder ≥90%, free-flowing solder

1.2 Resistance to soldering heat

Resistance to soldering heat is tested to IEC 60068-2-20:2008, test Tb, method 1.

Conditions:

Series	Solder bath temperature	Soldering time
MKT boxed (except 2.5 × 6.5 × 7.2 mm) coated uncoated (lead spacing >10 mm)	260 ±5 °C	10 ±1 s
MFP MKP (lead spacing >7.5 mm)		
MKT boxed (case 2.5 × 6.5 × 7.2 mm)		5 ±1 s
MKP (lead spacing ≤7.5 mm) MKT uncoated (lead spacing ≤10 mm) insulated (B32559)		<4 s recommended soldering profile for MKT uncoated (lead spacing ≤ 10 mm) and insulated (B32559)

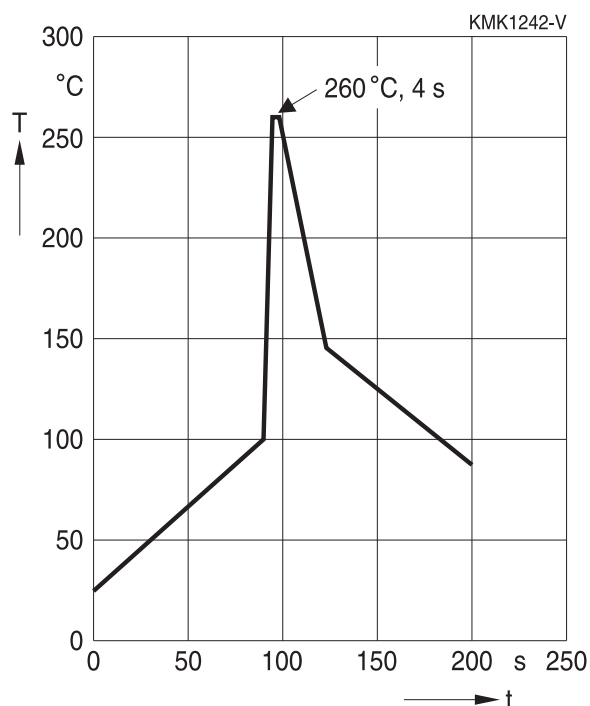

Immersion depth	2.0 +0/−0.5 mm from capacitor body or seating plane
Shield	Heat-absorbing board, (1.5 ±0.5) mm thick, between capacitor body and liquid solder
Evaluation criteria:	
Visual inspection	No visible damage
$\Delta C/C_0$	2% for MKT/MKP/MFP 5% for EMI suppression capacitors
$\tan \delta$	As specified in sectional specification

1.3 General notes on soldering

Permissible heat exposure loads on film capacitors are primarily characterized by the upper category temperature T_{max} . Long exposure to temperatures above this type-related temperature limit can lead to changes in the plastic dielectric and thus change irreversibly a capacitor's electrical characteristics. For short exposures (as in practical soldering processes) the heat load (and thus the possible effects on a capacitor) will also depend on other factors like:

- Pre-heating temperature and time
- Forced cooling immediately after soldering
- Terminal characteristics:
diameter, length, thermal resistance, special configurations (e.g. crimping)
- Height of capacitor above solder bath
- Shadowing by neighboring components
- Additional heating due to heat dissipation by neighboring components
- Use of solder-resist coatings



B32641B ... B32643B

High frequency

The overheating associated with some of these factors can usually be reduced by suitable countermeasures. For example, if a pre-heating step cannot be avoided, an additional or reinforced cooling process may possibly have to be included.

EPCOS recommendations

As a reference, the recommended wave soldering profile for our film capacitors is as follows:

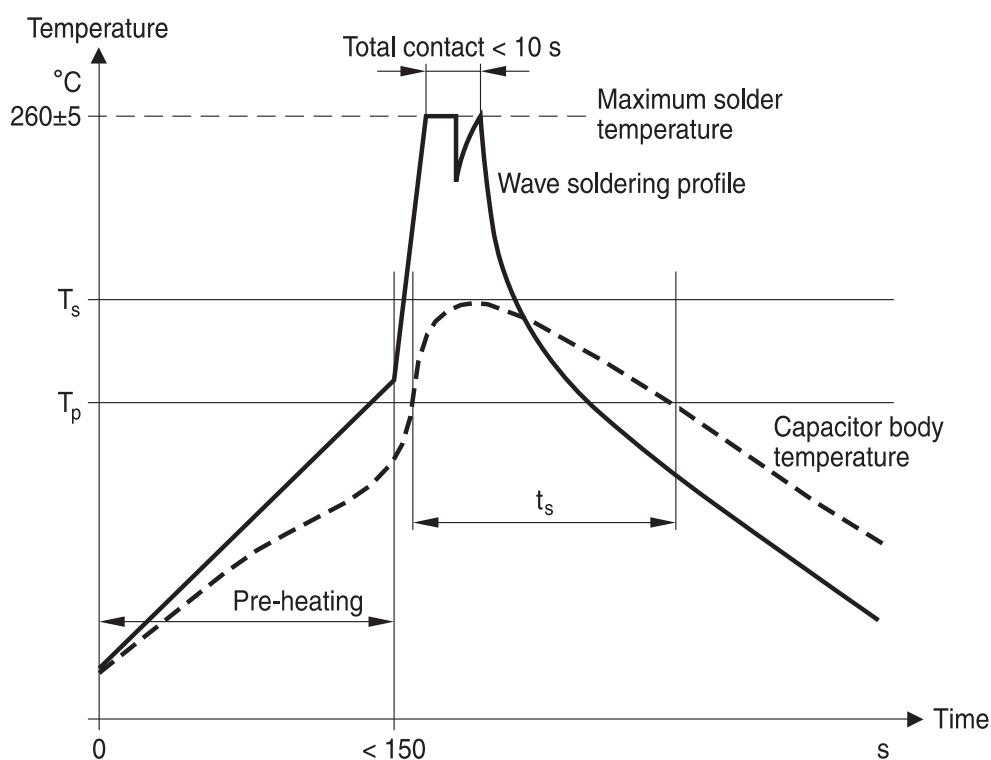

T_s: Capacitor body maximum temperature at wave soldering

T_p: Capacitor body maximum temperature at pre-heating

KMK1745-A-E

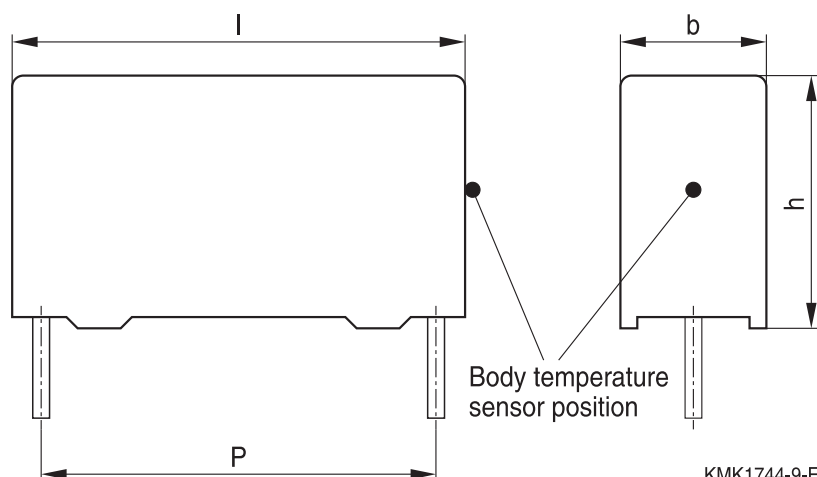

KMK1744-9-E



Body temperature should follow the description below:

- MKP capacitor
 - During pre-heating: $T_p \leq 110 \text{ }^\circ\text{C}$
 - During soldering: $T_s \leq 120 \text{ }^\circ\text{C}$, $t_s \leq 45 \text{ s}$
- MKT capacitor
 - During pre-heating: $T_p \leq 125 \text{ }^\circ\text{C}$
 - During soldering: $T_s \leq 160 \text{ }^\circ\text{C}$, $t_s \leq 45 \text{ s}$

When SMD components are used together with leaded ones, the film capacitors should not pass into the SMD adhesive curing oven. The leaded components should be assembled after the SMD curing step.

Leaded film capacitors are not suitable for reflow soldering.

In order to ensure proper conditions for manual or selective soldering, the body temperature of the capacitor (T_s) must be $\leq 120 \text{ }^\circ\text{C}$.

One recommended condition for manual soldering is that the tip of the soldering iron should be $< 360 \text{ }^\circ\text{C}$ and the soldering contact time should be no longer than 3 seconds.

For uncoated MKT capacitors with lead spacings $\leq 10 \text{ mm}$ (B32560/B32561) the following measures are recommended:

- pre-heating to not more than $110 \text{ }^\circ\text{C}$ in the preheater phase
- rapid cooling after soldering

Please refer to EPCOS Film Capacitor Data Book in case more details are needed.



B32641B ... B32643B

High frequency

Cautions and warnings

- Do not exceed the upper category temperature (UCT).
- Do not apply any mechanical stress to the capacitor terminals.
- Avoid any compressive, tensile or flexural stress.
- Do not move the capacitor after it has been soldered to the PC board.
- Do not pick up the PC board by the soldered capacitor.
- Do not place the capacitor on a PC board whose PTH hole spacing differs from the specified lead spacing.
- Do not exceed the specified time or temperature limits during soldering.
- Avoid external energy inputs, such as fire or electricity.
- Avoid overload of the capacitors.
- Consult us if application is with severe temperature and humidity condition.
- There are no serviceable or repairable parts inside the capacitor. Opening the capacitor or any attempts to open or repair the capacitor will void the warranty and liability of EPCOS.
- Please note that the standards referred to in this publication may have been revised in the meantime.

The table below summarizes the safety instructions that must always be observed. A detailed description can be found in the relevant sections of the chapters "General technical information" and "Mounting guidelines".

Topic	Safety information	Reference chapter "General technical information"
Storage conditions	Make sure that capacitors are stored within the specified range of time, temperature and humidity conditions.	4.5 "Storage conditions"
Flammability	Avoid external energy, such as fire or electricity (passive flammability), avoid overload of the capacitors (active flammability) and consider the flammability of materials.	5.3 "Flammability"
Resistance to vibration	Do not exceed the tested ability to withstand vibration. The capacitors are tested to IEC 60068-2-6:2007. EPCOS offers film capacitors specially designed for operation under more severe vibration regimes such as those found in automotive applications. Consult our catalog "Film Capacitors for Automotive Electronics".	5.2 "Resistance to vibration"

Topic	Safety information	Reference chapter "Mounting guidelines"
Soldering	Do not exceed the specified time or temperature limits during soldering.	1 "Soldering"
Cleaning	Use only suitable solvents for cleaning capacitors.	2 "Cleaning"



Topic	Safety information	Reference chapter "Mounting guidelines"
Embedding of capacitors in finished assemblies	When embedding finished circuit assemblies in plastic resins, chemical and thermal influences must be taken into account. Caution: Consult us first, if you also wish to embed other uncoated component types!	3 "Embedding of capacitors in finished assemblies"

Display of ordering codes for EPCOS products

The ordering code for one and the same product can be represented differently in data sheets, data books, other publications and the website of EPCOS, or in order-related documents such as shipping notes, order confirmations and product labels. **The varying representations of the ordering codes are due to different processes employed and do not affect the specifications of the respective products.** Detailed information can be found on the Internet under www.epcos.com/orderingcodes.



B32641B ... B32643B

High frequency

Symbols and terms

Symbol	English	German
α	Heat transfer coefficient	Wärmeübergangszahl
α_C	Temperature coefficient of capacitance	Temperaturkoeffizient der Kapazität
A	Capacitor surface area	Kondensatoroberfläche
β_C	Humidity coefficient of capacitance	Feuchtekoeffizient der Kapazität
C	Capacitance	Kapazität
C_R	Rated capacitance	Nennkapazität
ΔC	Absolute capacitance change	Absolute Kapazitätsänderung
$\Delta C/C$	Relative capacitance change (relative deviation of actual value)	Relative Kapazitätsänderung (relative Abweichung vom Ist-Wert)
$\Delta C/C_R$	Capacitance tolerance (relative deviation from rated capacitance)	Kapazitätstoleranz (relative Abweichung vom Nennwert)
dt	Time differential	Differentielle Zeit
Δt	Time interval	Zeitintervall
ΔT	Absolute temperature change (self-heating)	Absolute Temperaturänderung (Selbsterwärmung)
$\Delta \tan \delta$	Absolute change of dissipation factor	Absolute Änderung des Verlustfaktors
ΔV	Absolute voltage change	Absolute Spannungsänderung
dV/dt	Time differential of voltage function (rate of voltage rise)	Differentielle Spannungsänderung (Spannungsflankensteilheit)
$\Delta V/\Delta t$	Voltage change per time interval	Spannungsänderung pro Zeitintervall
E	Activation energy for diffusion	Aktivierungsenergie zur Diffusion
ESL	Self-inductance	Eigeninduktivität
ESR	Equivalent series resistance	Ersatz-Serienwiderstand
f	Frequency	Frequenz
f_1	Frequency limit for reducing permissible AC voltage due to thermal limits	Grenzfrequenz für thermisch bedingte Reduzierung der zulässigen Wechselspannung
f_2	Frequency limit for reducing permissible AC voltage due to current limit	Grenzfrequenz für strombedingte Reduzierung der zulässigen Wechselspannung
f_r	Resonant frequency	Resonanzfrequenz
F_D	Thermal acceleration factor for diffusion	Therm. Beschleunigungsfaktor zur Diffusion
F_T	Derating factor	Deratingfaktor
i	Current (peak)	Stromspitze
I_C	Category current (max. continuous current)	Kategoriestrom (max. Dauerstrom)



Symbol	English	German
I_{RMS}	(Sinusoidal) alternating current, root-mean-square value	(Sinusförmiger) Wechselstrom
i_z	Capacitance drift	Inkonstanz der Kapazität
k_0	Pulse characteristic	Impuls Kennwert
L_S	Series inductance	Serieninduktivität
λ	Failure rate	Ausfallrate
λ_0	Constant failure rate during useful service life	Konstante Ausfallrate in der Nutzungsphase
λ_{test}	Failure rate, determined by tests	Experimentell ermittelte Ausfallrate
P_{diss}	Dissipated power	Abgegebene Verlustleistung
P_{gen}	Generated power	Erzeugte Verlustleistung
Q	Heat energy	Wärmeenergie
ρ	Density of water vapor in air	Dichte von Wasserdampf in Luft
R	Universal molar constant for gases	Allg. Molarkonstante für Gas
R	Ohmic resistance of discharge circuit	Ohmscher Widerstand des Entladekreises
R_i	Internal resistance	Innenwiderstand
R_{ins}	Insulation resistance	Isolationswiderstand
R_P	Parallel resistance	Parallelwiderstand
R_S	Series resistance	Serienwiderstand
S	severity (humidity test)	Schärfegrad (Feuchtetest)
t	Time	Zeit
T	Temperature	Temperatur
τ	Time constant	Zeitkonstante
$\tan \delta$	Dissipation factor	Verlustfaktor
$\tan \delta_D$	Dielectric component of dissipation factor	Dielektrischer Anteil des Verlustfaktors
$\tan \delta_P$	Parallel component of dissipation factor	Parallelanteil des Verlustfaktors
$\tan \delta_S$	Series component of dissipation factor	Serienanteil des Verlustfaktors
T_A	Temperature of the air surrounding the component	Temperatur der Luft, die das Bauteil umgibt
T_{max}	Upper category temperature	Obere Kategorietemperatur
T_{min}	Lower category temperature	Untere Kategorietemperatur
t_{OL}	Operating life at operating temperature and voltage	Betriebszeit bei Betriebstemperatur und -spannung
T_{op}	Operating temperature, $T_A + \Delta T$	Betriebstemperatur, $T_A + \Delta T$
T_R	Rated temperature	Nenntemperatur
T_{ref}	Reference temperature	Referenztemperatur
t_{SL}	Reference service life	Referenz-Lebensdauer



B32641B ... B32643B

High frequency

Symbol	English	German
V_{AC}	AC voltage	Wechselspannung
V_C	Category voltage	Kategorie spannung
$V_{C,RMS}$	Category AC voltage	(Sinusförmige) Kategorie-Wechselspannung
V_{CD}	Corona-discharge onset voltage	Teilentlade-Einsatzspannung
V_{ch}	Charging voltage	Ladespannung
V_{DC}	DC voltage	Gleichspannung
V_{FB}	Fly-back capacitor voltage	Spannung (Flyback)
V_i	Input voltage	Eingangsspannung
V_o	Output voltage	Ausgangsspannung
V_{op}	Operating voltage	Betriebsspannung
V_p	Peak pulse voltage	Impuls-Spitzen spannung
V_{pp}	Peak-to-peak voltage Impedance	Spannungshub
V_R	Rated voltage	Nennspannung
\hat{V}_R	Amplitude of rated AC voltage	Amplitude der Nenn-Wechselspannung
V_{RMS}	(Sinusoidal) alternating voltage, root-mean-square value	(Sinusförmige) Wechselspannung
V_{SC}	S-correction voltage	Spannung bei Anwendung "S-correction"
V_{sn}	Snubber capacitor voltage	Spannung bei Anwendung "Beschaltung"
Z	Impedance	Scheinwiderstand
e	Lead spacing	Rastermaß

Important notes

The following applies to all products named in this publication:

1. Some parts of this publication contain **statements about the suitability of our products for certain areas of application**. These statements are based on our knowledge of typical requirements that are often placed on our products in the areas of application concerned. We nevertheless expressly point out **that such statements cannot be regarded as binding statements about the suitability of our products for a particular customer application**. As a rule, EPCOS is either unfamiliar with individual customer applications or less familiar with them than the customers themselves. For these reasons, it is always ultimately incumbent on the customer to check and decide whether an EPCOS product with the properties described in the product specification is suitable for use in a particular customer application.
2. We also point out that **in individual cases, a malfunction of electronic components or failure before the end of their usual service life cannot be completely ruled out in the current state of the art, even if they are operated as specified**. In customer applications requiring a very high level of operational safety and especially in customer applications in which the malfunction or failure of an electronic component could endanger human life or health (e.g. in accident prevention or lifesaving systems), it must therefore be ensured by means of suitable design of the customer application or other action taken by the customer (e.g. installation of protective circuitry or redundancy) that no injury or damage is sustained by third parties in the event of malfunction or failure of an electronic component.
3. **The warnings, cautions and product-specific notes must be observed.**
4. In order to satisfy certain technical requirements, **some of the products described in this publication may contain substances subject to restrictions in certain jurisdictions (e.g. because they are classed as hazardous)**. Useful information on this will be found in our Material Data Sheets on the Internet (www.epcos.com/material). Should you have any more detailed questions, please contact our sales offices.
5. We constantly strive to improve our products. Consequently, **the products described in this publication may change from time to time**. The same is true of the corresponding product specifications. Please check therefore to what extent product descriptions and specifications contained in this publication are still applicable before or when you place an order. We also **reserve the right to discontinue production and delivery of products**. Consequently, we cannot guarantee that all products named in this publication will always be available. The aforementioned does not apply in the case of individual agreements deviating from the foregoing for customer-specific products.
6. Unless otherwise agreed in individual contracts, **all orders are subject to the current version of the "General Terms of Delivery for Products and Services in the Electrical Industry" published by the German Electrical and Electronics Industry Association (ZVEI)**.

Important notes

7. **Our manufacturing sites serving the automotive business apply the IATF 16949 standard.** The IATF certifications confirm our compliance with requirements regarding the quality management system in the automotive industry. Referring to customer requirements and customer specific requirements (“CSR”) TDK always has and will continue to have the policy of respecting individual agreements. Even if IATF 16949 may appear to support the acceptance of unilateral requirements, we hereby like to emphasize that **only requirements mutually agreed upon can and will be implemented in our Quality Management System.** For clarification purposes we like to point out that obligations from IATF 16949 shall only become legally binding if individually agreed upon.
8. The trade names EPCOS, CeraCharge, CeraDiode, CeraLink, CeraPad, CeraPlas, CSMP, CTVS, DeltaCap, DigiSiMic, ExoCore, FilterCap, FormFit, LeaXield, MiniBlue, MiniCell, MKD, MKK, MotorCap, PCC, PhaseCap, PhaseCube, PhaseMod, PhiCap, PowerHap, PQSine, PQvar, SIFERRIT, SIFI, SIKOREL, SilverCap, SIMDAD, SiMic, SIMID, SineFormer, SIOV, ThermoFuse, WindCap are **trademarks registered or pending** in Europe and in other countries. Further information will be found on the Internet at www.epcos.com/trademarks.

Release 2018-06

X-ON Electronics

Largest Supplier of Electrical and Electronic Components

Click to view similar products for [Film Capacitors](#) category:

Click to view products by [EPCOS](#) manufacturer:

Other Similar products are found below :

[F339X134748MIP2T0](#) [F450KG153J250ALH0J](#) [750-1018](#) [FKP1-1500160010P15](#) [FKP1R031007D00JYSD](#) [FKP1R031507E00JYSD](#)
[FKP1U024707E00KYSD](#) [82DC4100CK60J](#) [82EC1100DQ50K](#) [PFR5101J100J11L16.5TA18](#) [PME261JB5220KR19T0](#) [A451GK223M040A](#)
[A561ED221M450A](#) [QXJ2E474KTPT](#) [QXL2B333KTPT](#) [R49AN347000A1K](#) [EEC2G505HQA406](#) [B25668A6676A375](#) [B25673A4282E140](#)
[BFC233868148](#) [BFC2370GC222](#) [C3B2AD44400B20K](#) [C4ASWBU3220A3EK](#) [CB027C0473J--](#) [CB177I0184J--](#) [CB182K0184J--](#) [23PW210](#)
[950CQW5H-F](#) [SBDC3470AA10J](#) [SCD105K122A3-22](#) [2N3155](#) [A571EH331M450A](#) [FKP1-2202KV5P15](#) [FKS3-680040010P10](#)
[QXL2E473KTPT](#) [445450-1](#) [B25669A3996J375](#) [46KI322000M1M](#) [46KR415050M1K](#) [4BSNBX4100ZBFJ](#) [MKP383510063JKP2T0](#)
[MKPY2-.02230020P15](#) [MKT 1813-368-015](#) [4055292001](#) [46KN410000N1K](#) [EEC2E106HQA405](#) [EEC2G205HQA402](#) [EEC2G805HQA415](#)
[P409CP224M250AH470](#) [82EC2150DQ50K](#)