

Highly efficient, regulated dual-outputs, ambient energy manager for TEG with optional primary battery

Features

Ultra-low-power start-up:

- Cold start from 60mV input voltage and 150µW input power with the optional external module (typical)
- Cold start from 380mV and 100µW input power without the optional external module (typical)

Ultra-low-power boost regulator:

- Open-circuit voltage sensing for MPPT every 21 s
- Configurable MPPT with 2-pin programming
- Selectable Voc ratios of 50, 55 or 75%
- Input voltage operation range from 50 mV to 3.5 V
- MPPT voltage operation range from 50 mV to 3.5 V
- Constant impedance matching (ZMPPT)

Integrated 1.2/1.8 V LDO regulator:

- Up to 20 mA load current
- Power gated dynamically by external control
- Selectable output voltage

Integrated 1.8/2.5/3.3 V LDO regulator:

- Up to 80 mA load current with 300 mV drop-out
- Power gated dynamically by external control
- Selectable output voltage

Flexible energy storage management:

- Selectable overcharge and overdischarge protection for any type of rechargeable battery or (super)capacitor
- Fast supercapacitor charging
- Warning when the battery is running low
- Warning when output voltage regulators are available

Optional primary battery:

- Automatic switching to the primary battery when the secondary battery is exhausted

Integrated balun for dual-cell supercapacitor

Applications

- TEG harvesting
- Industrial monitoring
- Home automation
- Smart agriculture
- Wireless sensor nodes

Description

The AEM20940 is an integrated energy management subsystem that extracts DC power from a TEG to simultaneously store energy in a rechargeable element and supply the system with two independent regulated voltages. The AEM20940 allows to extend battery lifetime and ultimately eliminates the primary energy storage element in a large range of wireless applications like industrial monitoring, home automation and smart agriculture.

The AEM20940 harvests the available input current up to 110 mA. It integrates an ultra-low-power boost converter to charge a storage element, such as a Li-ion battery, a thin film battery, a supercapacitor or a conventional capacitor. The boost converter operates with input voltages in a range from 50 mV to 3.5 V. With its unique cold start circuit, it can start operating with empty storage elements at an input voltage as low as 380 mV and an input power of just 100 µW. Thanks to an external optional module, the input voltage for coldstart lowers to 60 mV with an input power of just 150 µW.

The low-voltage supply typically drives a microcontroller at 1.2 V or 1.8 V. The high-voltage supply typically drives a radio transceiver at 1.8 V, 2.5 V or 3.3 V. Both are driven by highly-efficient LDO (Low Drop-Out) regulators for low noise and high stability.

Configuration pins determine various operating modes by setting predefined conditions for the energy storage element (overcharge or overdischarge voltages), and by selecting the voltage of the high-voltage supply and the low-voltage supply.

The chip integrates all the active elements for powering a typical wireless sensor. Five capacitors and two inductors are required, available in the small 0402 and 0603 size, respectively. With only seven external components, integration is maximum, footprint and BOM are minimum, optimizing the time-to-market and the costs of WSN designs.

Device information

Part number	Package	Body size
20AEM20940C0000	QFN 28-pin	5 mm x 5 mm

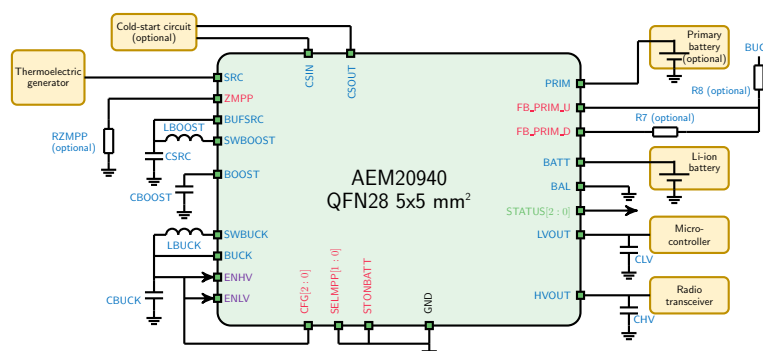

Contents

1	Introduction	3
2	Absolute Maximum Ratings	5
3	Thermal Resistance	5
4	Typical Electrical Characteristics at 25 °C	5
5	Recommended Operation Conditions	6
6	Functional Block Diagram	7
7	Theory of Operation	8
7.1	Deep sleep & Wake up modes	8
7.2	Normal mode	9
7.3	Overvoltage mode	9
7.4	Primary mode	10
7.5	Shutdown mode	10
7.6	Maximum power point tracking	10
7.7	Balun for dual-cell supercapacitor	10
8	System Configuration	11
8.1	Battery and LDOs configuration	11
8.2	MPPT configuration	11
8.3	Primary battery configuration	11
8.4	ZMPPT configuration	11
8.5	Start-on-battery configuration	11
8.6	No battery configuration	11
8.7	Storage element information	11
9	Typical Application Circuits	13
9.1	Example: Circuit 1	13
9.2	Example: Circuit 2	14
10	Performance Data	18
10.1	BOOST conversion efficiency 10 uH	18
10.2	BOOST conversion efficiency with 22 uH	19
10.3	Quiescent current	19
10.4	High-voltage LDO regulation	20
10.5	Low-voltage LDO regulation	20
10.6	High-voltage LDO efficiency	21
10.7	Low-voltage LDO efficiency	21
11	Schematic	22
12	Layout	23
13	Package Information	24
13.1	Plastic quad flatpack no-lead (QFN28 5mm x 5mm)	24
13.2	Board layout	24

List of Figures

3	1	Simplified schematic view	3
5	2	Pinout diagram QFN28	4
5	3	Functional block diagram	7
5	4	Simplified schematic view of the AEM20940	8
5	5	Diagram of the AEM20940 modes	8
5	6	Typical application circuit 1	13
5	7	Typical application circuit 2	14
6	8	Cold start with a capacitor connected to BATT	15
6	9	Cold start with a battery connected to BATT	15
7	10	Overvoltage mode	16
7	11	Shutdown mode (without primary battery)	16
8	12	Switch to primary battery if the battery is overdischarged	17
8	13	Boost efficiency for I _{src} at 100 μA, 1 mA, 10 mA and 100 mA with L _{boost} = 10 mH	18
8	14	Boost efficiency for I _{src} at 100 μA, 1 mA, 10 mA and 100 mA with L _{boost} = 22 mH	19
8	15	Quiescent current with LDOs on and off	19
8	16	HVOUT at 3.3 V and 2.5 V	20
8	17	LVOUT at 1.2 V and 1.8 V	20
8	18	HVOUT efficiency at 1.8 V, 2.5 V and 3.3 V	21
8	19	Efficiency of BUCK cascaded with LVOUT at 1.2 V and 1.8 V	21
8	20	Schematic example	22
8	21	Layout example for the AEM20940 and its passive components	23
8	22	QFN28 5mm x 5mm	24
8	23	Board layout	24

List of Tables

1	Pins description	4
2	Absolute maximum ratings	5
3	Thermal data	5
4	Electrical characteristics	6
5	Recommended operating conditions	6
6	LDOs configurations	9
7	Usage of CFG[2:0]	11
8	Usage of SELMPP[1:0]	11
9	BOM example for AEM20940 and its required passive components	22

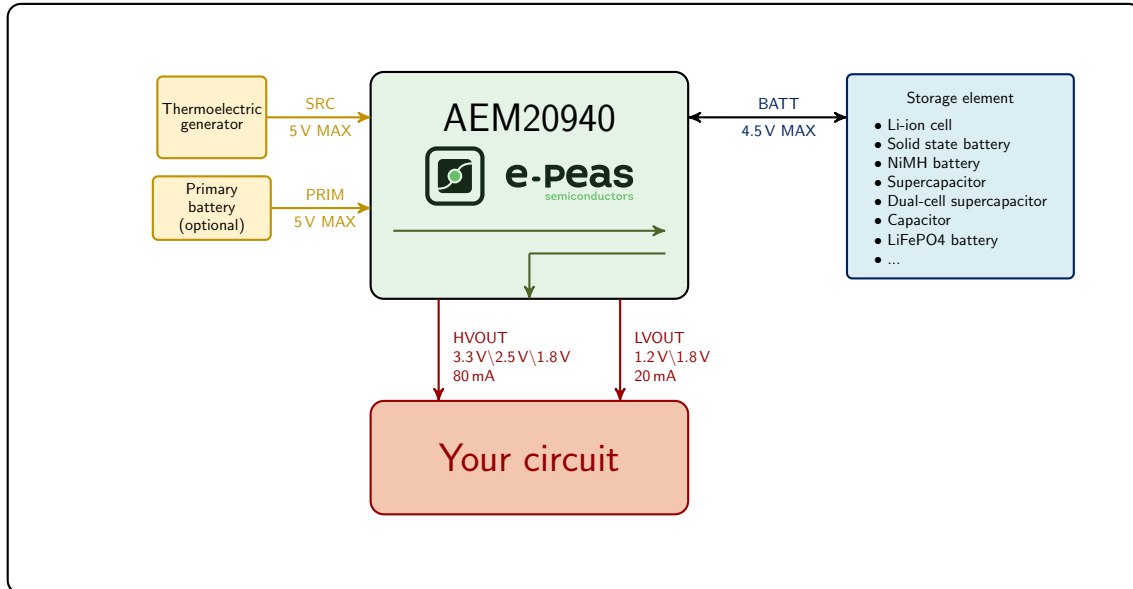

Figure 1: Simplified schematic view

1 Introduction

The AEM20940 is a full-featured energy efficient power management circuit able to charge a storage element (battery or supercapacitor, connected to **BATT**) from an energy source (connected to **SRC**) as well as to supply loads at different operating voltages through two powers supplying LDO regulators (**LVOUT** and **HVOUT**).

The heart of the AEM20940 is a cascade of two regulated switching converters, namely the boost converter and the buck converter with high-power conversion efficiency (See page 18). At first start-up, as soon as a required cold start voltage of 380 mV and a scant amount of power of just 100 μ W available from the harvested energy source, the AEM cold starts. With an optional external module, the cold start voltage can be reduced to 60 mV for a scant amount of power of just 150 μ W. After the cold start, the AEM can extract the power available from the source as long as the input voltage is comprised between 50 mV and 5 V. Note that the **STONBATT** pin makes it possible to bypass the cold start procedure using the pre-charged storage element to start the AEM20940 (see page 11).

Through three configuration pins (**CFG[2:0]**), the user can select a specific operating mode from a range of seven modes that cover most application requirements without any dedicated external component. These operating modes define the LDO output voltages and the protection levels of the storage

element.

The Maximum Power Point (MPP) ratio can be configured using two configuration pins (**SELMPP[1:0]**) (See page 11).

Two logic control pins are provided (**ENLV** and **ENHV**) to dynamically activate or deactivate the LDO regulators that supply the low and high-voltage load, respectively. The status pin **STATUS[0]** alerts the user that the LDOs are operational and can be enabled. This signal can also be used to enable an optional external regulator.

If the battery voltage gets depleted, the LDOs are power gated and the controller is no longer supplied by the storage element to protect it from further discharge. Around 600 ms before the shutdown of the AEM, the status pin **STATUS[1]** alerts the user for a clean shutdown of the system.

However, if the storage element gets depleted and an optional primary battery is connected on **PRIM**, the chip automatically uses it as a source to recharge the storage element before switching back to the ambient source. This guarantees continuous operation even under the most adverse conditions (See page 10). **STATUS[1]** is asserted when the primary battery is providing power.

The status of the MPP controller is reported with one dedicated status pin (**STATUS[2]**). The status pin is asserted when an MPP calculation is being performed.

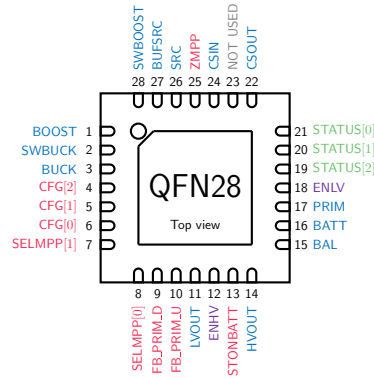

Figure 2: Pinout diagram QFN28

NAME	PIN NUMBER	FUNCTION
Power pins		
BOOST	1	Output of the boost converter.
SWBUCK	2	Switching node of the buck converter.
BUCK	3	Output of the buck converter.
LVOUT	11	Output of the low voltage LDO regulator.
HVOUT	14	Output of the high voltage LDO regulator.
BAL	15	Connection to mid-point of a dual-cell supercapacitor (optional). Must be connected to GND if not used.
BATT	16	Connection to the energy storage element, battery or capacitor. Cannot be left floating.
PRIM	17	Connection to the primary battery (optional). Must be connected to GND if not used.
CSIN	24	Input of the external cold start module.
CSOUT	22	Output of the external cold start module.
SRC	26	Connection to the harvested energy source.
BUFSRC	27	Connection to an external capacitor buffering the boost converter input.
SWBOOST	28	Switching node of the boost converter.
Configuration pins		
CFG[2]	4	Used for the configuration of the threshold voltages for the energy storage element and the output voltage of the LDOs.
CFG[1]	5	
CFG[0]	6	
SELMPP[1]	7	Used for the configuration of the MPP ratio.
SELMPP[0]	8	
FB_PRIM_D	9	Used for the configuration of the primary battery (optional). Must be connected to GND if not used.
FB_PRIM_U	10	
STONBATT	13	Used for the configuration of the cold start (optional). Must be connected to GND if not used.
ZMPPT	25	Used for the configuration of the ZMPPT (optional). Must be left floating if not used.
Control pins		
ENHV	12	Enabling pin for the high-voltage LDO.
ENLV	18	Enabling pin for the low-voltage LDO.
Status pins		
STATUS[2]	19	Logic output. Asserted when the AEM performs a MPP evaluation.
STATUS[1]	20	Logic output. Asserted if the battery voltage falls below <i>Vovdis</i> or if the AEM is taking energy from the primary battery.
STATUS[0]	21	Logic output. Asserted when the LDOs can be enabled.
Other pins		
GND	Exposed Pad	Ground connection, should be solidly tied to the PCB ground plane.

Table 1: Pins description

2 Absolute Maximum Ratings

Parameter	Rating
V _{src}	3.5 V
Operating junction temperature	-40 °C to +125 °C
Storage temperature	-65 °C to +150 °C

Table 2: Absolute maximum ratings

3 Thermal Resistance

Package	θ_{JA}	θ_{JC}	Unit
QFN28	38.3	2.183	°C/W

Table 3: Thermal data

ESD CAUTION

	ESD (ELECTROSTATIC DISCHARGE) SENSITIVE DEVICE These devices have limited built-in ESD protection and damage may thus occur on devices subjected to high-energy ESD. Therefore, proper ESD precautions should be taken to avoid performance degradation or loss of functionality.	
	V _{ESD}	Human-body model according to Jedec JS001-2017 ± 500 V Charge device model according to Jedec JS002-2014 ± 1.000 V

4 Typical Electrical Characteristics at 25 °C

Symbol	Parameter	Conditions	Min	Typ	Max	Unit
Input voltage and input power with the cold start circuit						
P _{srcCS}	Source power required for cold start.	During cold start	150			μW
V _{src}	Input voltage of the energy source.	During cold start	60		3.5	V
		After cold start	0.05		3.5	
Input voltage and input power without the cold start circuit						
P _{srcCS}	Source power required for cold start.	During cold start	100			μW
V _{src}	Input voltage of the energy source.	During cold start	0.38		3.5	V
		After cold start	0.05		3.5	
I _{src}	Input current of the energy source				110	mA
DC-DC converters						
V _{boost}	Output of the boost converter.	During normal operation	2.2		4.5	V
V _{buck}	Output of the buck converter.	During normal operation	2	2.2	2.5	
Storage element						
V _{batt}	Voltage on the storage element.	Rechargeable battery	2.2		4.5	V
		Capacitor	0		4.5	V
T _{crit}	Time before shutdown once STATUS[1] has been asserted.		400	600	800	ms
V _{prim}	Voltage on the primary battery.		0.6		5	V
I _{prim}	Current from the primary battery.			20		mA
V _{fb_prim_u}	Feedback for the minimal voltage level on the primary battery.		0.15		1.1	V
V _{ovch}	Maximum voltage accepted on the storage element before disabling the boost converter.	see Table 7	2.7		4.5	V
V _{chrdy}	Minimum voltage required on the storage element before enabling the LDOs after a cold start.	see Table 7	2.3		4.04	V
V _{ovdis}	Minimum voltage accepted on the storage element before switching to primary battery or entering into a shutdown.	see Table 7	2.2		3.6	V



Symbol	Parameter	Conditions	Min	Typ	Max	Unit
Low-voltage LDO regulator						
Vlv	Output voltage of the low-voltage LDO.	see Table 7	1.2		1.8	V
Ilv	Load current from the low-voltage LDO.		0		20	mA
High-voltage LDO regulator						
Vhv	Output voltage of the high-voltage LDO.	see Table 7	1.8		3.3	V
Ihv	Load current from the high-voltage LDO.		0		80	mA
Logic output pins						
STATUS[2:0]	Logic output levels on the status pins.	Logic high (VOH)	1.98	Vbatt		V
		Logic low (VOL)	-0.1		0.1	V

Table 4: Electrical characteristics

5 Recommended Operation Conditions

Symbol	Parameter	Min	Typ	Max	Unit	
External components						
CSRC	Capacitor decoupling the BUFSRC pin.	8	10	150	μF	
CBOOST	Capacitor of the boost converter.	10	22	25	μF	
LBOOST	Inductor of the boost converter.	4	10	25	μH	
CBUCK	Capacitor of the buck converter.	8	10	22	μF	
LBUCK	Inductor of the buck converter.	4	10	25	μH	
CLV	Capacitor decoupling the low-voltage LDO regulator.	8	10	14	μF	
CHV	Capacitor decoupling the high-voltage LDO regulator.	8	10	14	μF	
CBATT	Optional - Capacitor on BATT if no storage element is connected (See page 11).	150			μF	
RZMPP	Optional - Resistor for the ZMPPT configuration (See page 11).	10		1M	Ω	
RP	Optional - Resistor to be used with a primary battery. Equal to R7 + R8 (See page 11).	100		500	kΩ	
Logic input pins						
ENHV	Enabling pin for the high-voltage LDO ¹ .	Logic high (VOH)	1.75	Vbuck	Vbuck	V
		Logic low (VOL)	-0.01	0	0.01	
ENLV	Enabling pin for the low-voltage LDO ² .	Logic high (VOH)	1.75	Vbuck	Vboost	V
		Logic low (VOL)	-0.01	0	0.01	
SELMPP[1:0]	Configuration pins for the MPP evaluation (see Table 8).	Logic high (VOH)	Connect to BUCK			
		Logic low (VOL)	Connect to GND			
CFG[2:0]	Configuration pins for the storage element (see Table 7).	Logic high (VOH)	Connect to BUCK			
		Logic low (VOL)	Connect to GND			
STONBATT	Configuration pin to select the energy source during the cold start.	Logic high (VOH)	Connect to BATT			
		Logic low (VOL)	Connect to GND			

Table 5: Recommended operating conditions

Note 1: **ENHV** can be dynamically driven by a logic signal from the LV domain. For a static usage, connect to **BUCK** (High) or **GND** (Low).

Note 2: **ENLV** can be dynamically driven by a logic signal from the HV domain. For a static usage, connect to **BUCK** or **BOOST** (High) or **GND** (Low).

6 Functional Block Diagram

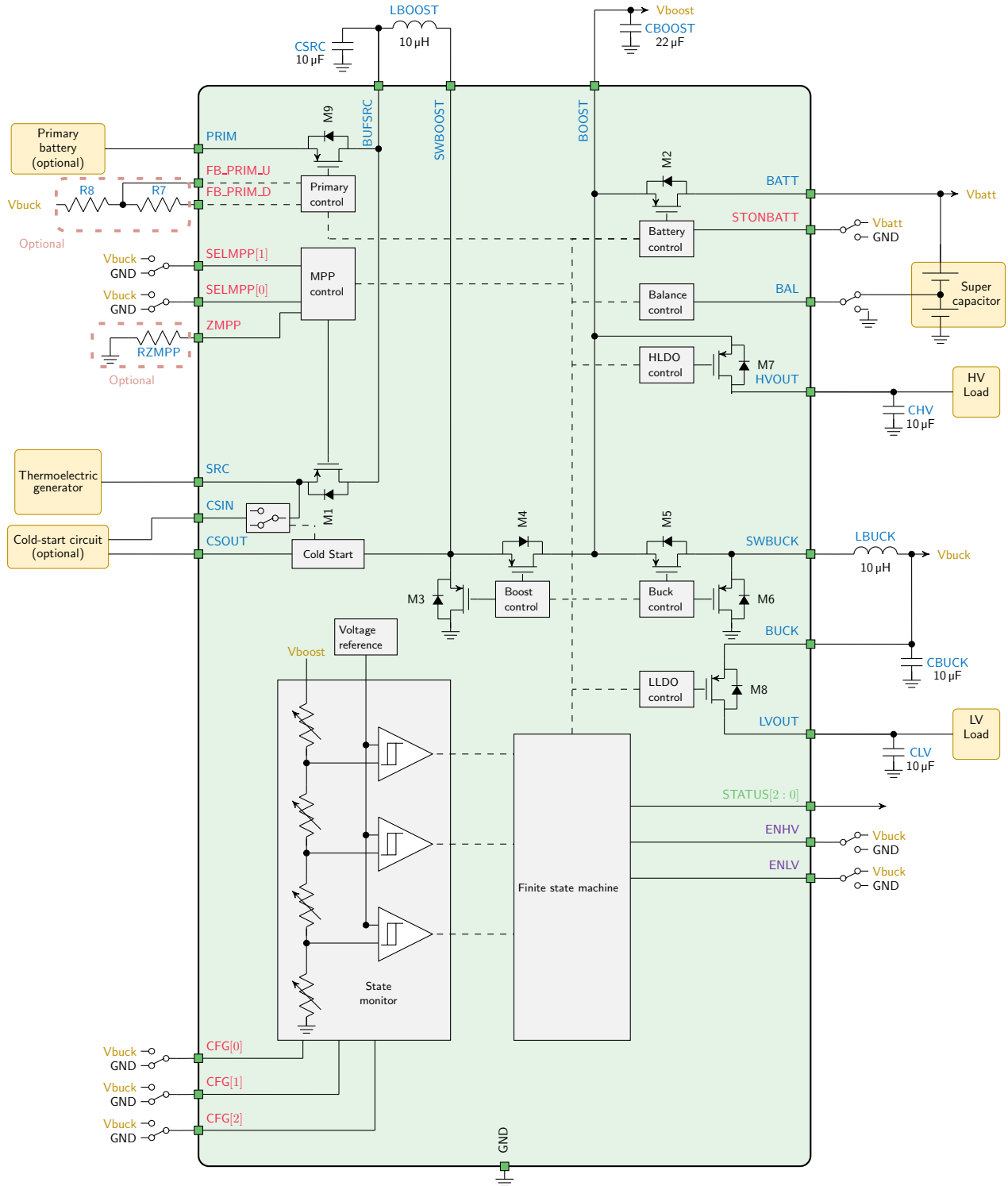

Figure 3: Functional block diagram

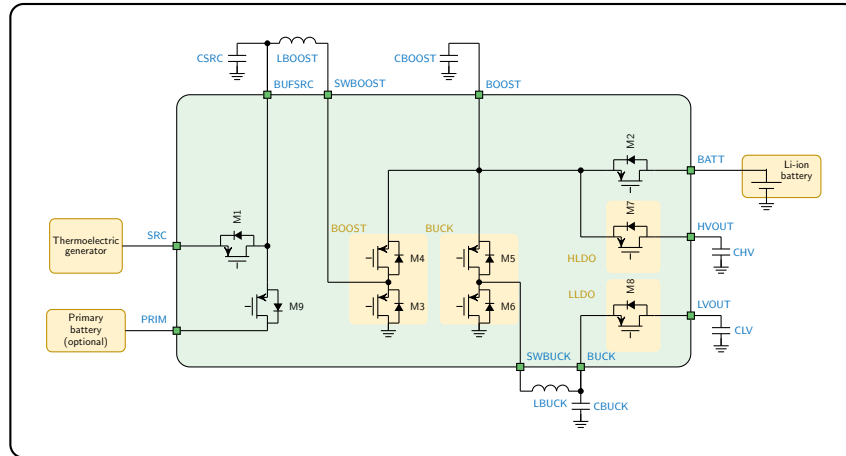

Figure 4: Simplified schematic view of the AEM20940

7 Theory of Operation

7.1 Deep sleep & Wake up modes

The **DEEP SLEEP MODE** is a state where all nodes are deeply discharged and there is no available energy to be harvested. As soon as the required cold start voltage of 380 mV and a sparse amount of power of just 100 μ W becomes available on **SRC**, the **WAKE UP MODE** is activated. **Vboost** and **Vbuck** rise up to a voltage of 2.2 V. **Vboost** then rises alone up to **Vovch**.

At that stage, both LDOs are internally deactivated. Therefore, **STATUS[0]** is equal to 0 as shown in Figure 8 and Figure 9.

When **Vboost** reaches **Vovch**, two scenarios are possible: in the first scenario, a supercapacitor or a capacitor having a voltage lower than **Vchrdy** is connected to the **BATT** node. In the second scenario, a charged battery is connected to the **BATT** node.

Wake up with the external cold start module

The external cold start module is an optional auto-oscillating circuit allowing the reduction of the minimum input voltage required for the cold start of the AEM. During the cold start, the input of the external module connected to **CSIN** is internally connected with the energy source connected to **SRC**. Once 60 mV and 150 μ W are available on **SRC**, the external cold start module generates at least 400 mV on **CSOUT**. This pin is connected to the internal cold start module allowing to wake up the AEM. Once **Vboost** and **Vbuck** rises up to a voltage of 2.2 V, the AEM disconnects **CSIN** and **SRC** and extract power directly from the input energy source through **SRC**. If the external module is not used on the application, **CSOUT** and **SRC** must be shorted, leaving **CSIN** pin floating. In this condition, 380 mV and a sparse amount of power of just 100 μ W are required to cold start the AEM.

Supercapacitor as a storage element

If the storage element is a supercapacitor, the storage element may need to be charged from 0 V. The boost converter charges **BATT** from the input source and by modulating the conductance of M2. During the charge of the **BATT** node, both LDOs are deactivated and **STATUS[0]** is de-asserted. When **Vbatt** reaches **Vchrdy**, the circuit goes to **NORMAL MODE**, **STATUS[0]** is asserted and the LDOs can be activated by the user using the **ENLV** and **ENHV** control pins as shown in Figure 8.

Battery as a storage element

If the storage element is a battery, but its voltage is lower than **Vchrdy**, then the storage element first needs to be charged until it reaches **Vchrdy**. Once **Vbatt** exceeds **Vchrdy**, or if the battery was initially charged above **Vchrdy**, the circuit goes to **NORMAL MODE**. **STATUS[0]** is asserted and the LDOs can be activated by the user thanks to **ENLV** and **ENHV** as shown in Figure 9.

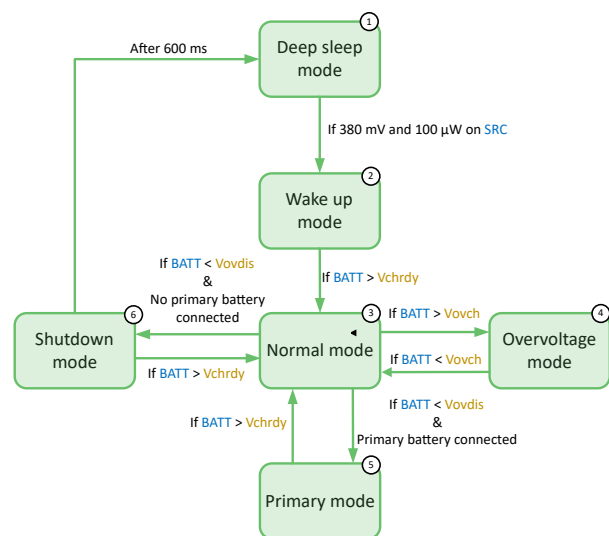

Figure 5: Diagram of the AEM20940 modes

7.2 Normal mode

Once the AEM goes to **NORMAL MODE**, three scenarios are possible:

- There is enough power provided by the source to maintain V_{batt} above V_{ovdis} but V_{batt} is below V_{ovch} . In that case, the circuit remains in **NORMAL MODE**.
- The source provides more power than the load consumes, and V_{batt} increases above V_{ovch} , the circuit goes to the **OVERVOLTAGE MODE**, as explained in the **Overvoltage mode** section.
- Due to a lack of power from the source, V_{batt} falls below V_{ovdis} . In this case, either the circuit goes into the **SHUTDOWN MODE** as explained in **Shutdown mode** section or, if a charged primary battery is connected on **PRIM**, the circuit shifts to **PRIMARY MODE** as described in the **Primary mode** section.

Boost

The boost (or step-up) converter raises the voltage available at **BUFSRC** to a level suitable for charging the storage element, in the range of 2.2 V to 4.5 V, according to the system configuration. This voltage (V_{boost}) is available at the **BOOST** pin. The switching transistors of the boost converter are M3 and M4, with the switching node available externally at **SWBOOST**. The reactive power components of this converter are the external inductor and capacitor **LBOOST** and **CBOOST**. Periodically, the MPP control circuit disconnects the source from the **BUFSRC** pin with the transistor M1 in order to measure the open-circuit voltage of the harvester on **SRC** and define the optimal level of voltage. **BUFSRC** is decoupled by the capacitor **CSRC**, which smooths the voltage against the current pulses induced by the boost converter.

The storage element is connected to the **BATT** pin, at a voltage V_{batt} . This node is linked to **BOOST** through the transistor M2. In **NORMAL MODE**, this transistor effectively shorts the battery to the **BOOST** node ($V_{batt} = V_{boost}$). When energy harvesting is occurring, the boost converter delivers a current that is shared between the battery and the loads. M2 is opened to disconnect the storage element when V_{batt} reaches V_{ovdis} . However, in such a scenario, the AEM20940 offers the possibility of connecting a primary battery to recharge V_{batt} up to the V_{chrdy} . The transistor M9 connects **PRIM** to **BUFSRC** and the transistor M1 is opened to disconnect the **SRC** input pin as explained in the **Primary mode** section and shown in Figure 12.

Buck

The buck (or step-down) converter lowers the voltage from V_{boost} to a constant V_{buck} value of 2.2 V. This voltage is available at the **BUCK** pin. The switching transistors of the buck converter are M5 and M6, with the switching node available externally at **SWBUCK**. The reactive power components of the buck converter are the external inductor **LBUCK** and the capacitor **CBUCK**.

LDO outputs

Two LDOs are available to supply loads at different operating voltages.

Through M7, V_{boost} supplies the high-voltage LDO that powers its load through **HVOUT**. This regulator delivers a clean voltage (V_{hv}) with a maximum current of 80 mA on **HVOUT**. In the built-in configuration modes, an output voltage of 1.8 V, 2.5 V or 3.3 V can be selected. The high-voltage output can be dynamically enabled or disabled with the logic control pin **ENHV**. The output is decoupled by the external capacitor **CHV**.

Through M8, V_{buck} supplies the low-voltage LDO that powers its load through **LVOUT**. This regulator delivers a clean voltage (V_{lv}) of 1.8 V or 1.2 V with a maximum current of 20 mA on **LVOUT**. The low-voltage output can be dynamically enabled or disabled with the logic control pin **ENLV**. The output is decoupled by the external capacitor **CLV**.

Status pin **STATUS[0]** alerts the user when the LDOs can be enabled as explained in the **Deep sleep & Wake up modes** section and in the **Shutdown mode** section. The table below shows the four possible configurations:

ENLV	ENHV	LV output	HV output
1	1	Enabled	Enabled
1	0	Enabled	Disabled
0	1	Disabled	Enabled
0	0	Disabled	Disabled

Table 6: LDOs configurations

7.3 Overvoltage mode

When V_{batt} reaches V_{ovch} , the charge is complete and the internal logic maintains V_{batt} around V_{ovch} with a hysteresis of a few mV as shown in Figure 10 to prevent damage to the storage element and to the internal circuitry. In this configuration, the boost converter is periodically activated to maintain V_{batt} and the LDOs are still available. Moreover, when the boost converter is not activated, the transistor M1 in Figure 4 is opened to prevent current from the source to the storage element when V_{src} is higher than V_{ovch} .

7.4 Primary mode

When V_{batt} drops below V_{ovdis} , the circuit compares the voltage on $PRIM$ with the voltage on FB_PRIM_U to determine whether a charged primary battery is connected on $PRIM$. The voltage on FB_PRIM_U is set thanks to two optional resistances as explained in the [Primary battery configuration](#) section. If the voltage on $PRIM$ divided by 4 is higher than the voltage on FB_PRIM_U , the circuit considers the primary battery as available and the circuit enters **PRIMARY MODE** as shown in Figure 12.

In that mode, transistor M1 is opened and the primary battery is connected to $BUFSRC$ through transistor M9 in order to become the source of energy for the AEM20940. The chip remains in this mode until V_{batt} reaches V_{chrdy} . When V_{batt} reaches V_{chrdy} , the circuit goes to **NORMAL MODE**. As long as the chip is in **PRIMARY MODE**, $STATUS[1]$ is asserted.

If no primary battery is used in the application, $PRIM$, FB_PRIM_U and FB_PRIM_D must be tied to GND.

In case of the primary mode, it is recommended to use a $CSRC$ capacitor of 150 μF .

7.5 Shutdown mode

When V_{batt} drops below V_{ovdis} and no power is available from a primary battery, the circuit shifts to **SHUTDOWN MODE** as shown in Figure 11 to prevent deep discharge potentially leading to damage to the storage element and instability of the LDOs. The circuit asserts $STATUS[1]$ in order to warn the system that a shutdown will occur. Both LDO regulators remain enabled. If no primary battery is used, this allows the load, whether it is powered on $LVOUT$ or $HVOUT$, to be interrupted by the low-to-high transition of $STATUS[1]$, and to take all appropriate actions before power shutdown.

If energy at the input source is available and V_{batt} recovers to V_{chrdy} within T_{crit} (~ 600 ms), the AEM returns in **NORMAL MODE**. But if, after T_{crit} , V_{batt} does not reach V_{chrdy} , the circuit goes to **DEEP SLEEP MODE**. The LDOs are deactivated and $BATT$ is disconnected from $BOOST$ to avoid damaging the battery due to the overdischarge. From there, the AEM will have to go through the wake-up procedure described in the [Deep sleep & Wake up modes](#) section.

7.6 Maximum power point tracking

During **NORMAL MODE**, **SHUTDOWN MODE** and a part of **WAKE UP MODE**, the boost converter is regulated thanks to an internal MPPT (Maximum Power Point Tracking) module. V_{mpp} is the voltage level of the MPP and depends on the input power available at the source. The MPPT module evaluates V_{mpp} as a given fraction of V_{oc} , the open-circuit voltage of the source. By temporarily disconnecting the source from $CSRC$ as shown in Figure 4 for 328 ms, the MPPT module estimates and maintains knowledge of V_{mpp} . This sampling occurs approximately every 21 s.

With the exception of this sampling process, the voltage across the source, V_{src} , is continuously compared to V_{mpp} . When V_{src} exceeds V_{mpp} by a small hysteresis, the boost converter is switched on, extracting electrical charges from the source and lowering its voltage. When V_{src} falls below V_{mpp} by a small hysteresis, the boost converter is switched off, allowing the harvester to accumulate new electrical charges into $CSRC$, which restores its voltage. In this manner, the boost converter regulates its input voltage so that the electrical current (or flow of electrical charges) that enters the boost converter yields the best power transfer from the harvester under any ambient conditions. The AEM20940 supports any V_{mpp} level in the range from 0.05 V to 5 V. It offers a choice of three values for the V_{mpp}/V_{oc} fraction or to match the input impedance of the BOOST converter with an impedance connected to the ZMPP terminal through configuration pins $SELMPP[1:0]$ as shown in Table 8. The status of the MPPT controller is reported through one dedicated status pin ($STATUS[2]$). The status pin is asserted when an MPP calculation is being performed.

7.7 Balun for dual-cell supercapacitor

The balun circuit allows users to balance the internal voltage in a dual-cell supercapacitor in order to avoid damaging the super-capacitor because of excessive voltage on one cell. If BAL is connected to GND, the balun circuit is disabled. This configuration must be used if a battery, a capacitor or a single-cell supercapacitor is connected on $BATT$. If BAL is connected to the node between the cells of a supercapacitor, the balun circuit compensates for any mismatch of the two cells that could lead to overcharge of one of both cells. The balun circuit ensures that BAL remains close to $V_{batt}/2$. This configuration must be used if a dual-cell supercapacitor is connected on $BATT$.

8 System Configuration

Configuration pins			Storage element threshold voltages			LDOs output voltages		Typical use	
CFG[2]	CFG[1]	CFG[0]	Vovch	Vchrdy	Vovdis	Vhv	Vlv		
1	1	1	4.12 V	3.67 V	3.60 V	3.3 V	1.8 V	Li-ion battery	
1	1	0	4.12 V	4.04 V	3.60 V	3.3 V	1.8 V	Solid state battery	
1	0	1	4.12 V	3.67 V	3.01 V	2.5 V	1.8 V	Li-ion/NiMH battery	
1	0	0	2.70 V	2.30 V	2.20 V	1.8 V	1.2 V	Single-cell supercapacitor	
0	1	1	4.50 V	3.67 V	2.80 V	2.5 V	1.8 V	Dual-cell supercapacitor	
0	1	0	4.50 V	3.92 V	3.60 V	3.3 V	1.8 V	Dual-cell supercapacitor	
0	0	1	3.63 V	3.10 V	2.80 V	2.5 V	1.8 V	LiFePO4 battery	
0	0	0	Reserved for future use						

Table 7: Usage of CFG[2:0]

8.1 Battery and LDOs configuration

Through three configuration pins (CFG[2:0]), the user can set a particular operating mode from a range that covers most application requirements, without any dedicated external component as shown in Table 7. The three threshold levels are defined as:

- **Vovch**: Maximum voltage accepted on the storage element before disabling the boost converter;
- **Vchrdy**: Minimum voltage required on the storage element after a cold start before enabling the LDOs;
- **Vovdis**: Minimum voltage accepted on the storage element before considering the storage element as depleted.

See the Theory of Operation section for more information about the purposes of these thresholds.

The two LDOs output voltages are called Vhv and Vlv for the high and low-output voltages, respectively. In the built-in configuration mode, seven combinations of these voltage levels are hardwired and selectable through the CFG[2:0] configuration pins, covering most application cases.

8.2 MPPT configuration

Two dedicated configuration pins, SELMPP[1:0], allow selecting the MPP tracking ratio based on the characteristic of the input power source.

SELMPP[1]	SELMPP[0]	Vmpp/Voc
0	0	50%
0	1	55%
1	0	75%
1	1	ZMPP

Table 8: Usage of SELMPP[1:0]

8.3 Primary battery configuration

To use the primary battery, it is mandatory to determine Vprim_min, the voltage of the primary battery at which it has to be considered as empty. During the evaluation of Vprim_min, the circuit connects FB_PRIM_D to GND. The circuit uses a resistive divider between BUCK and FB_PRIM_D to define the voltage on FB_PRIM_U as Vprim_min divided by 4. When Vprim_min is not evaluated, FB_PRIM_D is left floating to avoid quiescent current on the resistive divider. If we define

the total resistor (R7 + R8) as RP, R7 and R8 are calculated as:

- $100\text{ k}\Omega \leq RP \leq 500\text{ k}\Omega$
- $R7 = \left(\frac{V_{prim_min}}{4} * RP\right) / 2.2\text{ V}$
- $R8 = RP - R7$

Note that FB_PRIM_U and FB_PRIM_D must be tied to GND if no primary battery is used.

8.4 ZMPPT configuration

Instead of working at a ratio of the open-circuit voltage, the AEM20940 can regulate the input impedance of the BOOST converter so that it matches a constant impedance connected to the ZMPP pin (RZMPP). In this case, the AEM20940 regulates Vsrc at a voltage equals to the product of the ZMPP impedance and the current available at the SRC input.

- $10\ \Omega \leq RZMPP \leq 1\text{ M}\Omega$

8.5 Start-on-battery configuration

Alternatively to the cold start procedure described in Deep sleep & Wake up modes section, by connecting STONBATT to BATT, the circuit can also start with the energy provided by the storage element connected on BATT if its voltage is higher than Vchrdy. Note the AEM20940 will not start if the voltage on BATT is lower than Vchrdy.

8.6 No battery configuration

If the harvested energy source is permanently available and covers the application purposes or if the application does not need to store energy when the harvested energy source is not available, the storage element may be replaced by an external capacitor CBATT of at least 150 μF.

8.7 Storage element information

The energy storage element of the AEM20940 can be a rechargeable battery, a supercapacitor or a large capacitor (at least 150 μF). It should be chosen so that its voltage does not fall below Vovdis even during occasional peaks of the load current. If the internal resistance of the storage element cannot sustain this voltage limit, it is advisable to buffer the battery with a capacitor.

The **BATT** pin that connects the storage element must never be left floating. If the application expects a disconnection of the battery (e.g. because of a user removable connector), the PCB should include a capacitor of at least 150 μF . The leakage current of the storage element should be small as leakage currents directly impact the quiescent current of the subsystem.

External inductors information

The AEM20940 operates with two standard miniature inductors of 10 μH . **LBOOST** and **LBUCK** must respectively sustain a peak current of at least 250 mA and 50 mA and a switching frequency of at least 10 MHz. Low equivalent series resistance (ESR) favors the power conversion efficiency of the boost and buck converters.

External capacitors information

The AEM20940 operates with four identical standard miniature ceramic capacitors of 10 μF and one miniature ceramic capacitor of 22 μF . The leakage current of the capacitors should be small as leakage currents directly impact the quiescent current of the subsystem.

CSRC

This capacitor acts as an energy buffer at the input of the boost converter. It prevents large voltage fluctuations when the boost converter is switching. The recommended value is 10 μF +/- 20%. If the primary mode is used, the minimum recommended value is 150 μF +/- 20%.

CBUCK

This capacitor acts as an energy buffer for the buck converter. It also reduces the voltage ripple induced by the current pulses inherent to the switched mode of the converter. The recommended value is 10 μF +/- 20%.

CBOOST

This capacitor acts as an energy buffer for the boost converter. It also reduces the voltage ripple induced by the current pulses inherent to the switched mode of the converter. The recommended value is 22 μF +/- 20%.

CHV and CLV

These capacitors ensure a high-efficiency load regulation of the high-voltage and low-voltage LDO regulators. Closed-loop stability requires the value to be in the range of 8 μF to 14 μF .

9 Typical Application Circuits

9.1 Example: Circuit 1

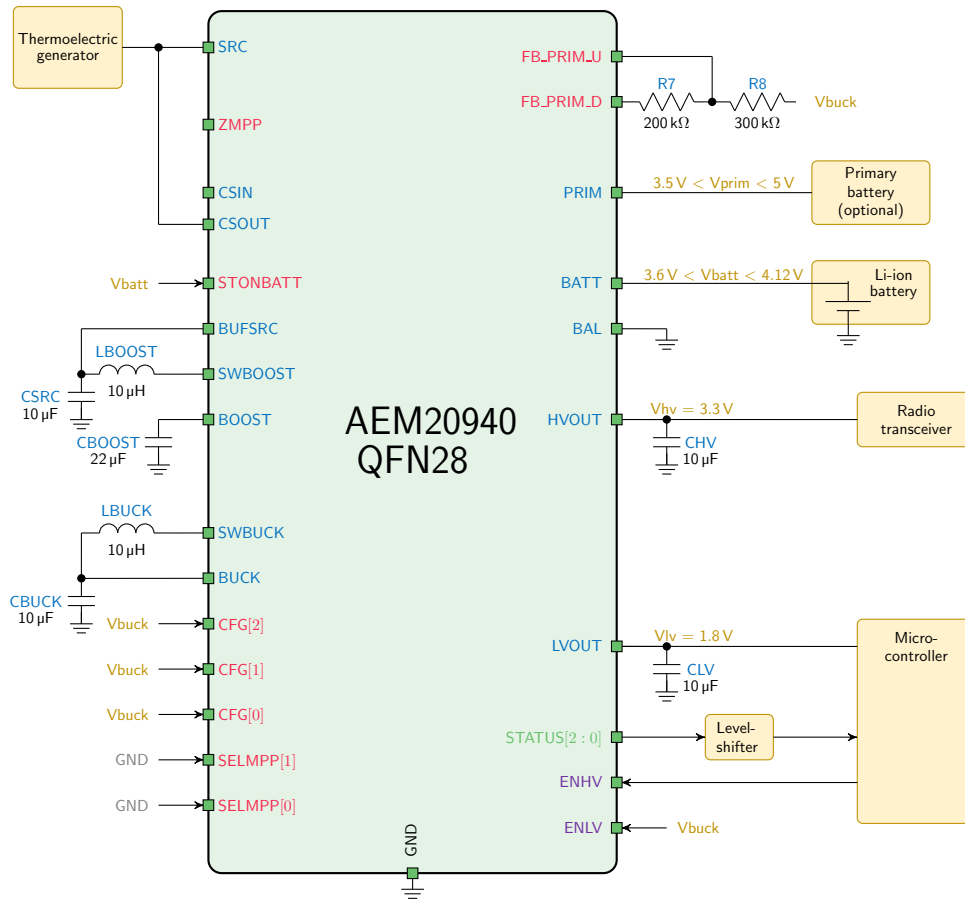

Figure 6: Typical application circuit 1

The energy source is a thermoelectric generator, and the storage element is a standard Li-ion battery. The radio communication makes use of a transceiver that operates from a 3.3 V supply. A microcontroller supplied by a 1.8 V supply controls the application.

STONBATT is tied to BATT, bypassing the cold start procedure to start thanks to the energy stored in the pre-charged Li-ion battery cell.

Once the start-on-battery configuration is enabled, the external cold start module is not useful for this application and by consequence, CSOUT and SRC are shorted.

This circuit uses a pre-defined operating mode, typical of systems that use standard components for radio and energy storage.

The operating mode pins are connected to:

- CFG[2:0] = 111

Referring to Table 7, in this mode, the threshold voltages are:

- Vovch = 4.12 V
- Vchrdy = 3.67 V
- Vovdis = 3.60 V

Moreover, the LDOs output voltages are:

- Vhv = 3.3 V
- Vlv = 1.8 V

A primary battery is also connected as a back-up solution. The minimal level allowed on this battery is set at 3.5 V. Following equations on page 11:

- RP = 0.5 MΩ
- R7 = $(\frac{3.5V}{4} * 0.5 M\Omega) / 2.2 V = 200 k\Omega$
- R8 = 0.5 MΩ - 200 kΩ = 300 kΩ

The MPP configuration pins SELMPP[1:0] are tied to GND (logic low), selecting an MPP ratio of 50%.

The ENLV enable pin for the low-voltage LDO is tied to BUCK. The microcontroller will be enabled after the system wake-up.

The application software can enable or disable the radio transceiver with a GPIO connected to ENHV.

9.2 Example: Circuit 2

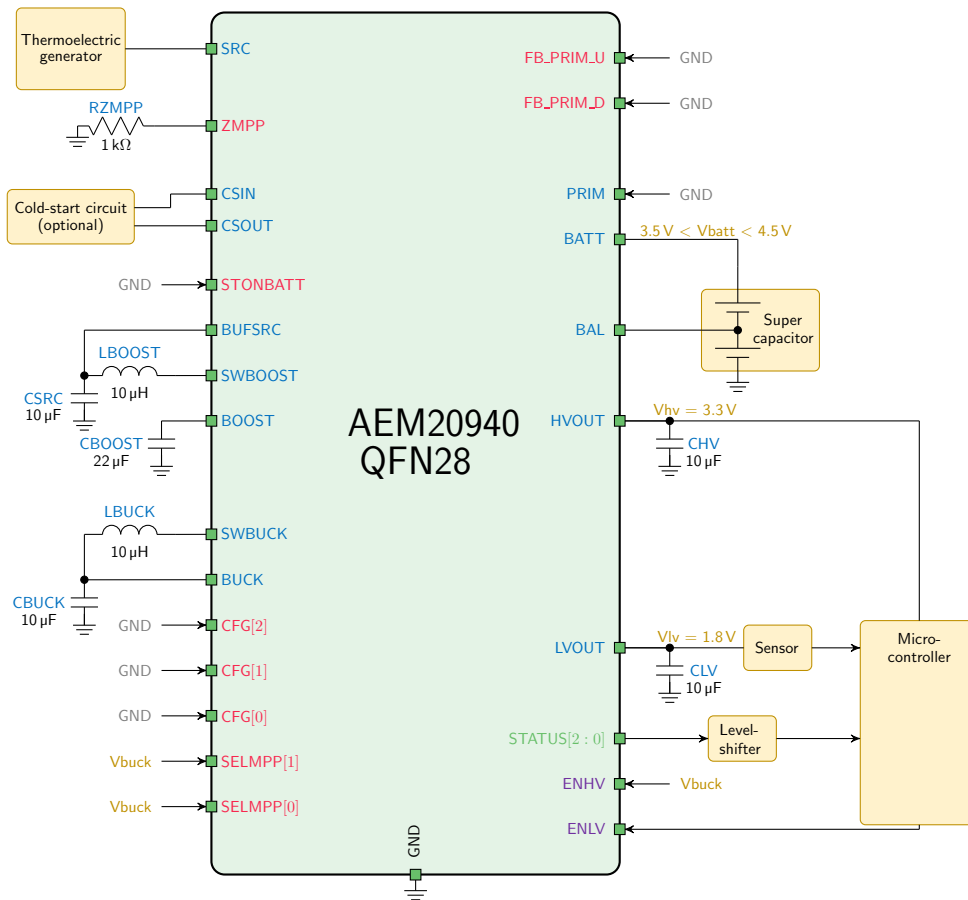

Figure 7: Typical application circuit 2

The energy source is a thermoelectric generator, and the storage element is a dual-cell supercapacitor. The supercapacitor can be completely depleted during the cold start. Consequently, **STONBATT** is tied to **GND** to use the input energy source.

To decrease the minimum voltage required for the cold start, the external cold start module has been connected to **CSIN** and **CSOUT**.

Moreover, **BAL** is connected to the dual-cell supercapacitor to compensate for any mismatch between the two cells and in that way to protect the supercapacitor.

A microcontroller pilots and collects information from a sensor. The operating mode pins are connected to:

- **CFG[2:0] = 010**

Referring to Table 7, in this operation mode, the threshold voltages are:

- **Vovch = 4.5 V**
- **Vchrdy = 3.92 V**
- **Vovdis = 3.60 V**

Moreover, the LDOs output voltages are:

- **Vhv = 3.3 V**
- **Vlv = 1.8 V**

The **ENHV** enable pin for the high-voltage LDO is tied to **BUCK**. The microcontroller is enabled when **Vbatt** and **Vboost** exceed **Vchrdy** as the high-voltage regulator supplies it.

The MPP configuration pins **SELMPP[1:0]** are tied to **BUCK** (logic high), selecting the ZMPPT configuration to match a 1 kΩ impedance.

No primary battery is connected and the **PRIM**, **FB_PRIM_U** and **FB_PRIM_D** pins are tied to **GND**.

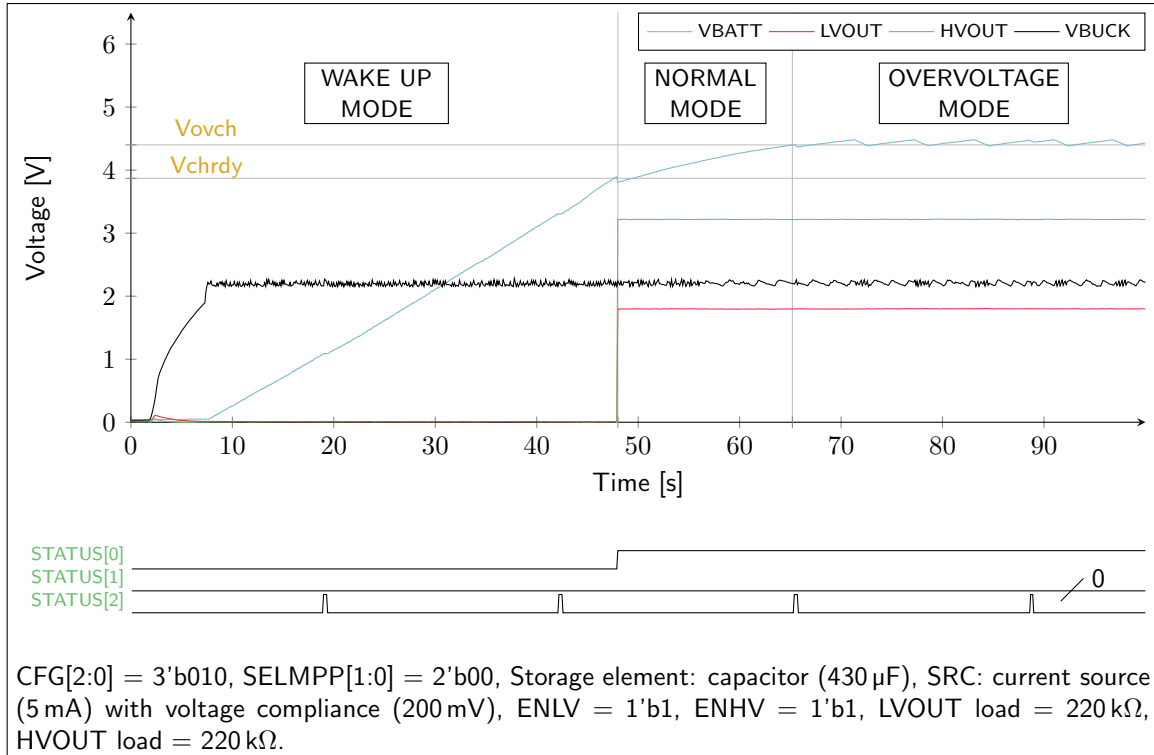

Figure 8: Cold start with a capacitor connected to BATT

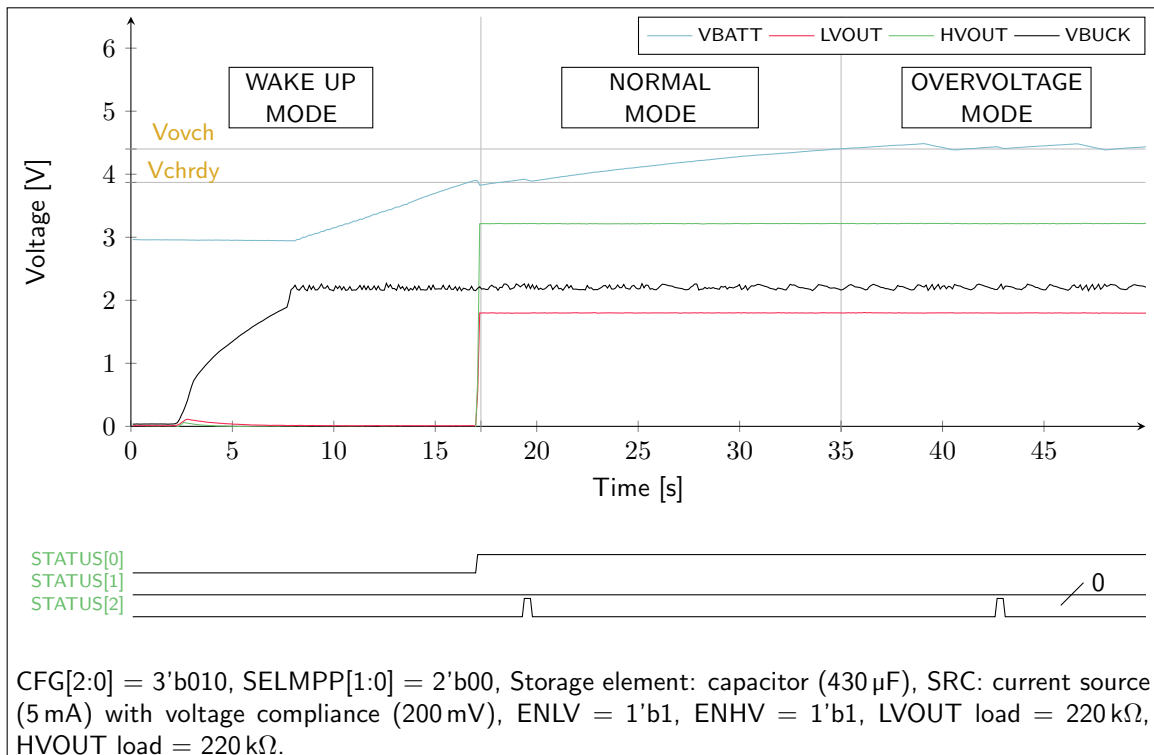

Figure 9: Cold start with a battery connected to BATT

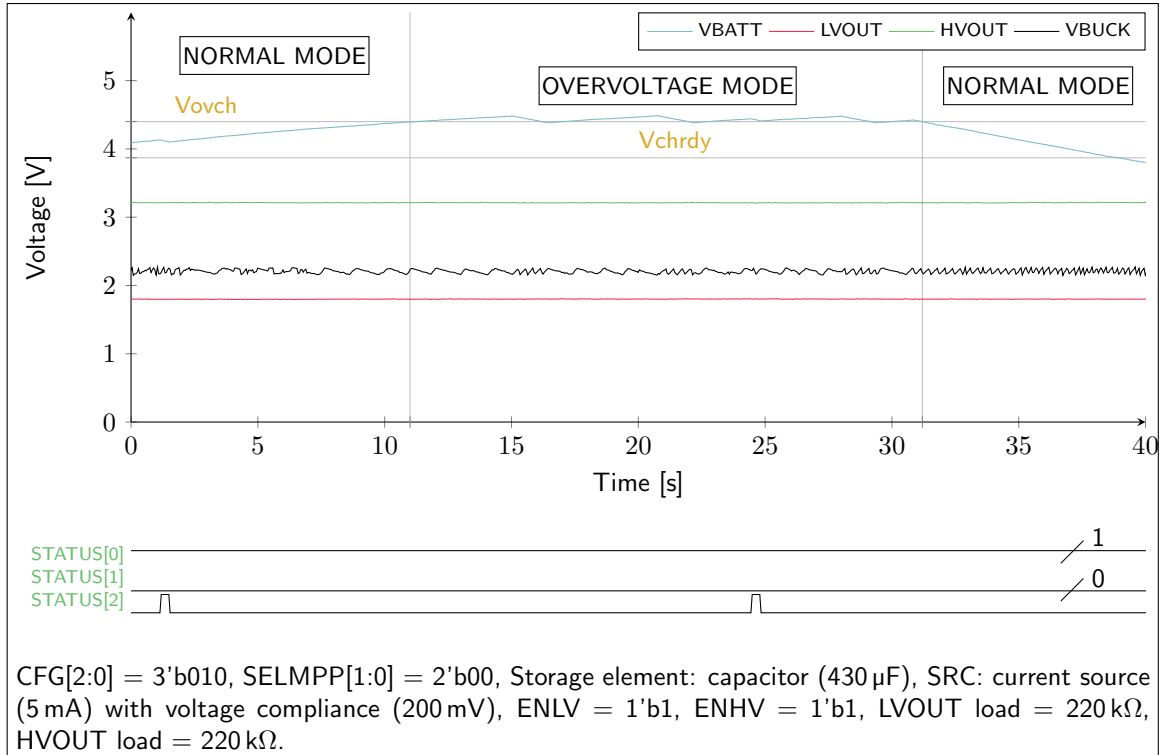

Figure 10: Overvoltage mode

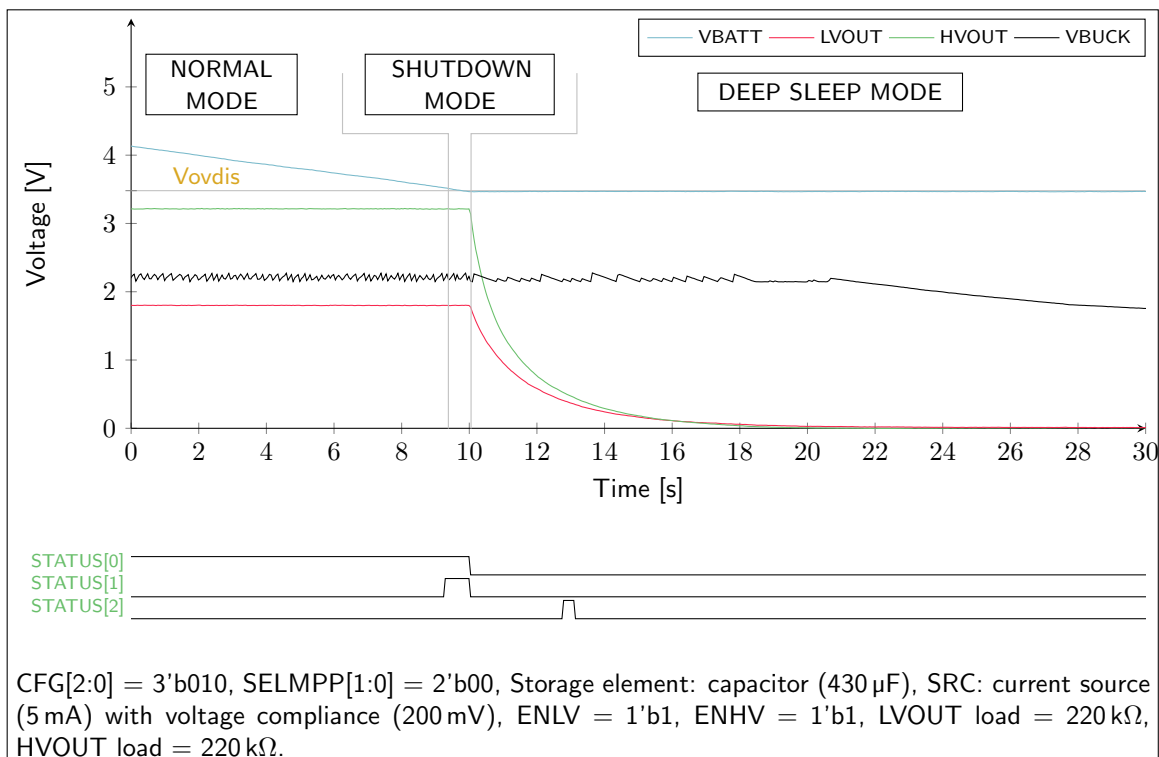

Figure 11: Shutdown mode (without primary battery)

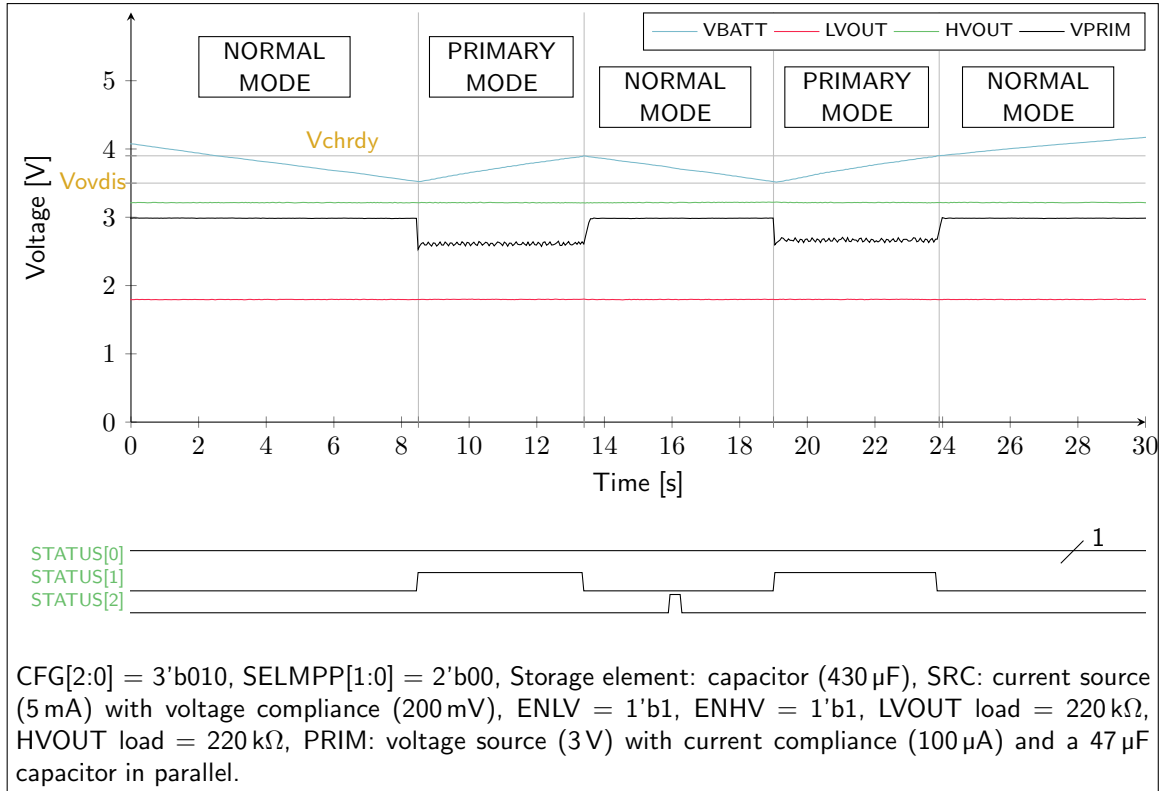

Figure 12: Switch to primary battery if the battery is overdischarged

10 Performance Data

10.1 BOOST conversion efficiency 10 μ H

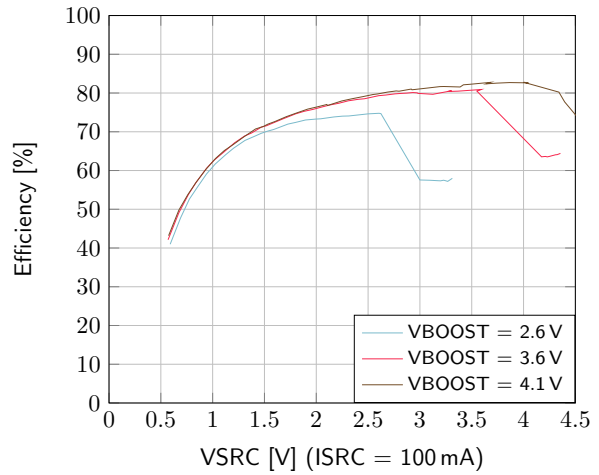
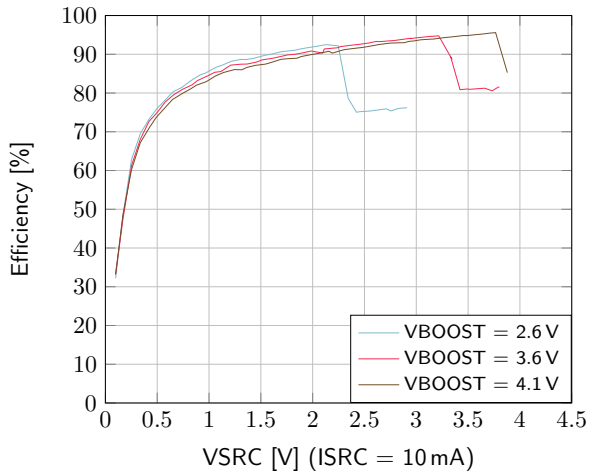
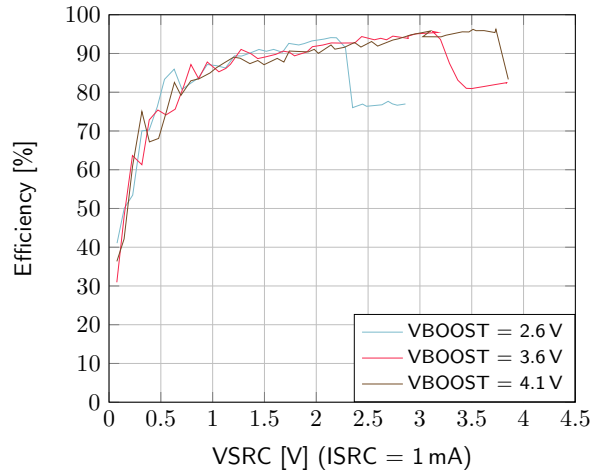
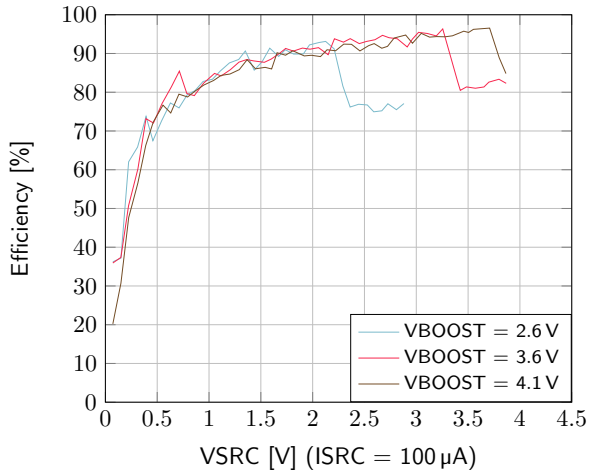

Figure 13: Boost efficiency for I_{src} at 100 μ A, 1 mA, 10 mA and 100 mA with $L_{boost} = 10 \mu$ H

10.2 BOOST conversion efficiency with 22 μH

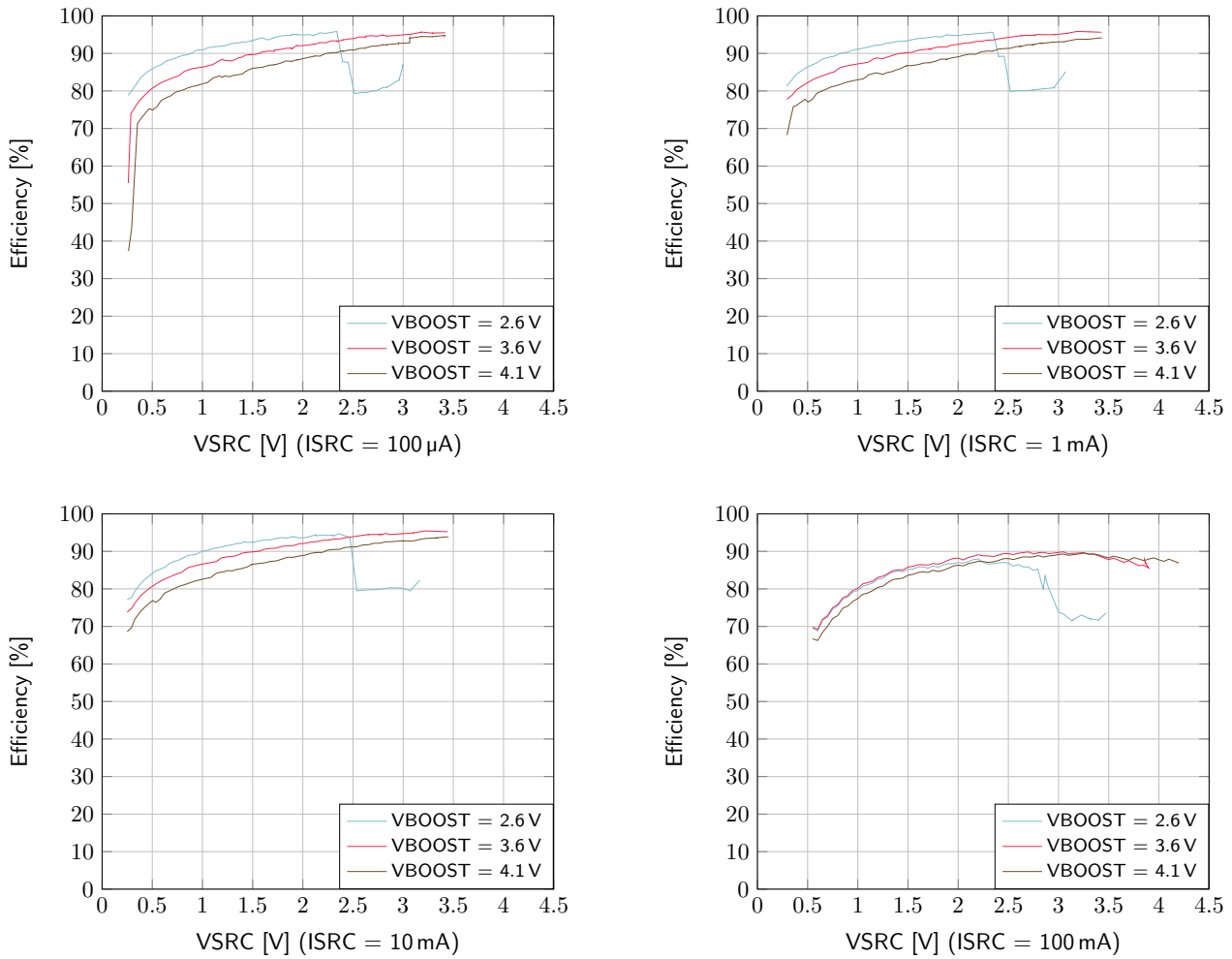

Figure 14: Boost efficiency for I_{src} at 100 μA , 1 mA, 10 mA and 100 mA with $L_{boost} = 22 \mu\text{H}$

For application with low voltage source, it is more efficient to use a 22 μH for the **LBOOST**

10.3 Quiescent current

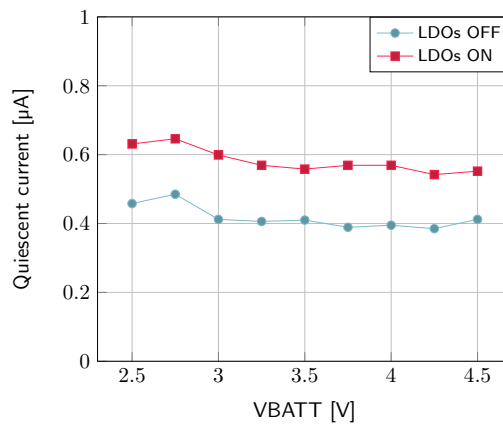

Figure 15: Quiescent current with LDOs on and off

10.4 High-voltage LDO regulation

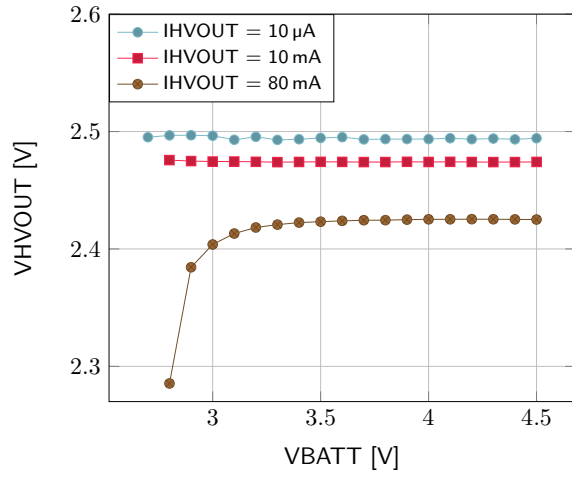
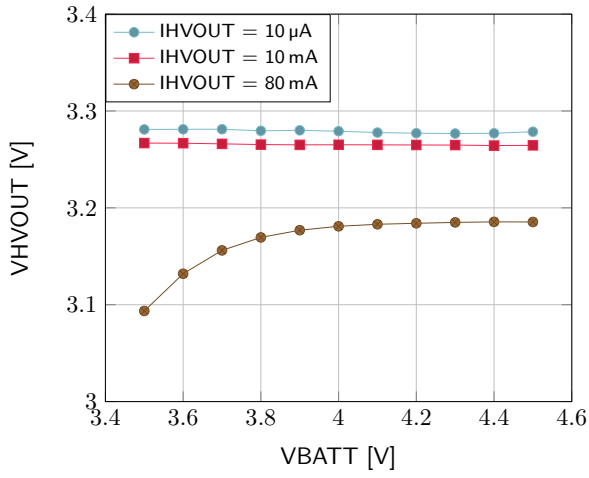

Figure 16: HVOUT at 3.3 V and 2.5 V

10.5 Low-voltage LDO regulation

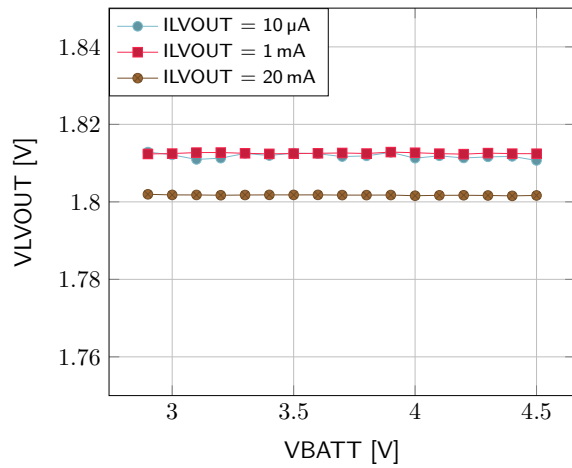
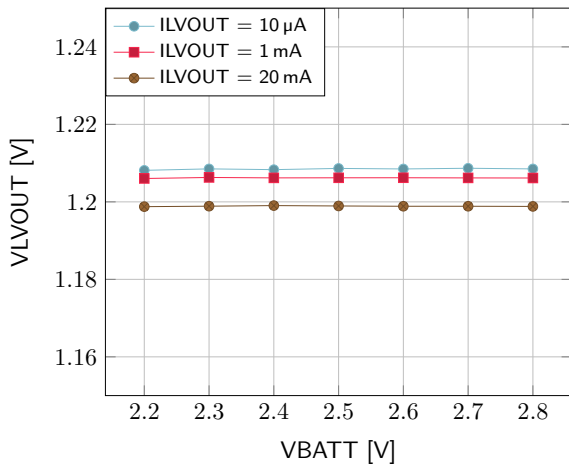

Figure 17: LVOUT at 1.2 V and 1.8 V

10.6 High-voltage LDO efficiency

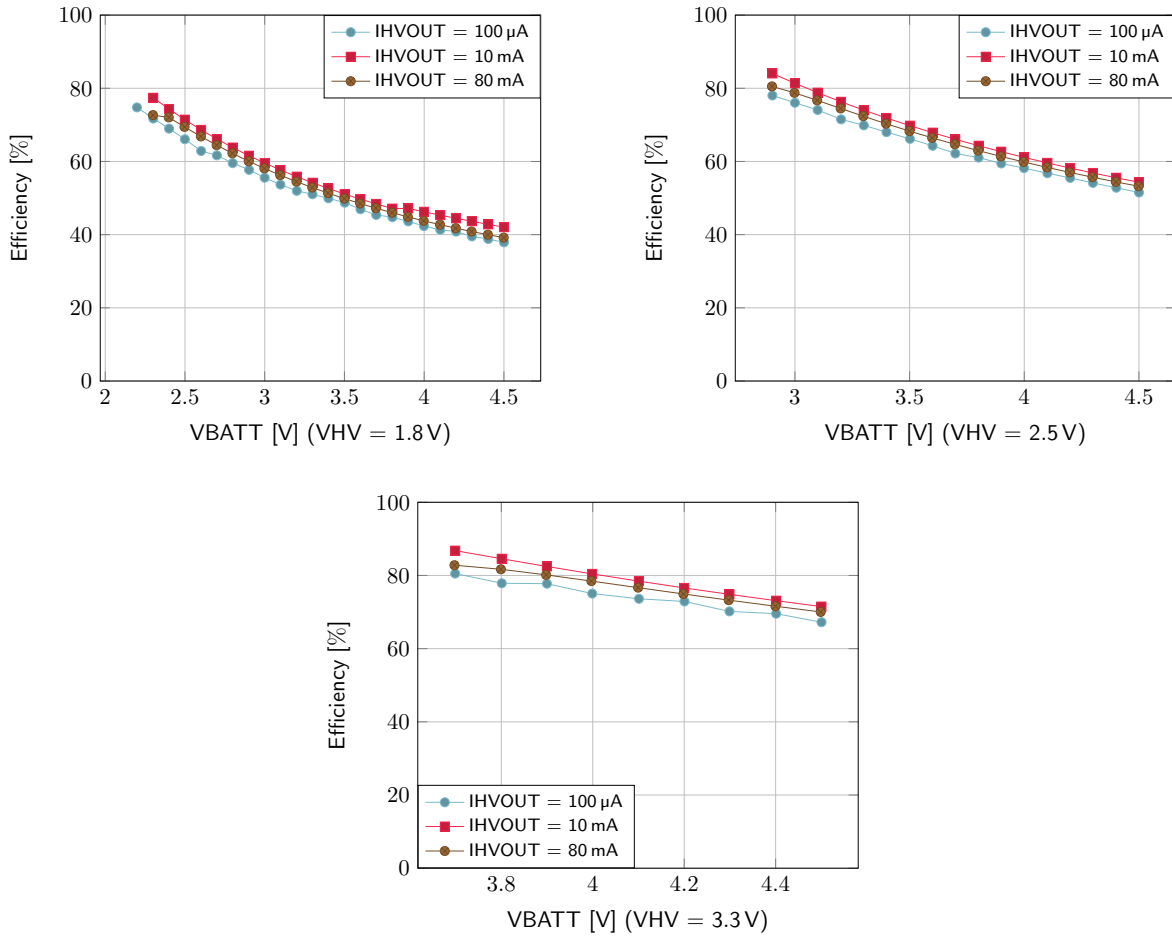

Figure 18: HVOUT efficiency at 1.8 V, 2.5 V and 3.3 V

The theoretical efficiency of a LDO can be simply calculated as $\frac{V_{out}}{V_{in}}$ if quiescent current can be neglected with regards to the output current. In the case of the high-voltage LDO, the theoretical efficiency is equal to $\frac{V_{hv}}{V_{batt}}$.

10.7 Low-voltage LDO efficiency

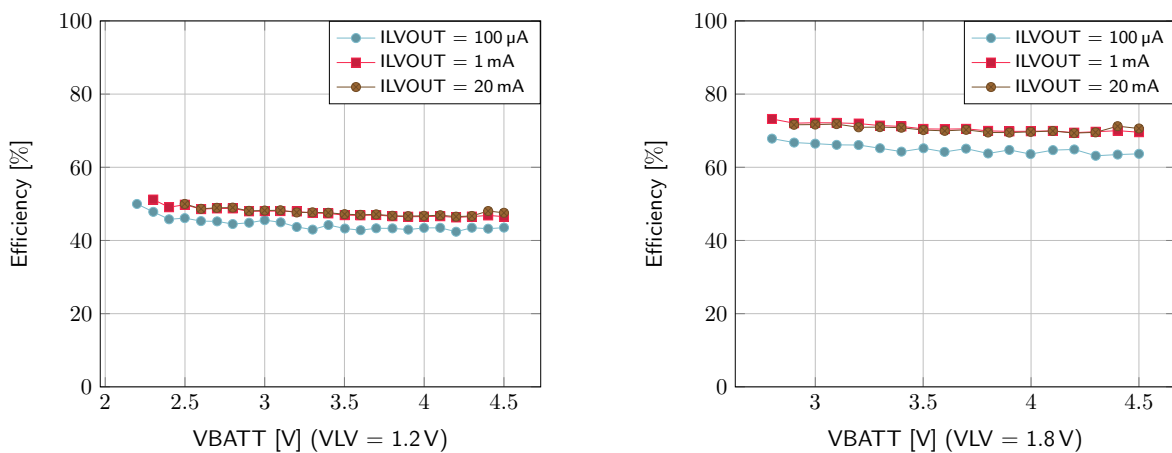

Figure 19: Efficiency of BUCK cascaded with LVOUT at 1.2 V and 1.8 V

The theoretical efficiency of the low-voltage LDO is equal to $\frac{V_{lv}}{V_{buck}}$. Starting from the battery, the efficiency of the buck converter has to be taken into account (see Figure 4). The efficiency between V_{batt} and V_{lv} is therefore equal to $\eta_{buck} \frac{V_{lv}}{V_{buck}}$.

11 Schematic

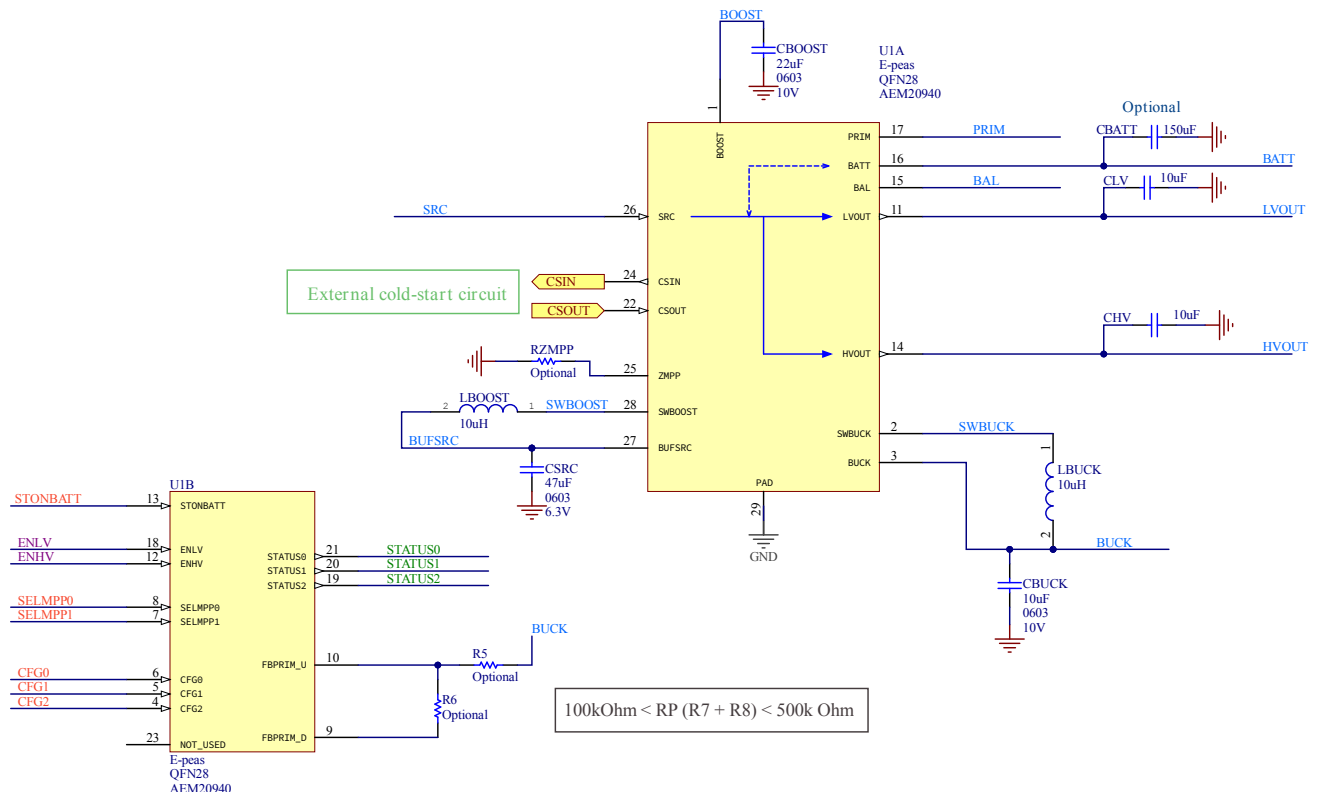

Figure 20: Schematic example

Designator	Description	Quantity	Manufacturer	Part Number
CBOOST	Ceramic Cap 22 μ F, 10 V, 20%, X5R 0603	1	Murata	GRM188R61A226ME15D
CBUCK	Ceramic Cap 10 μ F, 10 V, 20%, X5R	1	TDK	C1608X5R1A106M080AC
CHV	Ceramic Cap 10 μ F, 10 V, 20%, X5R	1	TDK	C1608X5R1A106M080AC
CLV	Ceramic Cap 10 μ F, 10 V, 20%, X5R	1	TDK	C1608X5R1A106M080AC
CSRC	Ceramic Cap 10 μ F, 10 V, 20%, X5R	1	TDK	C1608X5R1A106M080AC
LBOOST	Power Inductor 10 μ H - 0,54 A - LPS4012	1	Coilcraft	LPS4012-103MR
	Power Inductor 10 μ H - 0,8 A - 3015	1	Würth	744 040 321 00
LBUCK	Power Inductor 10 μ H - 0,25 A	1	TDK	MLZ1608M100WT
U1	AEM20940 - Symbol QFN28	1		order at sales@e-peas.com or Where to buy
	External cold start circuit ¹	1		more details at support@e-peas.com

Table 9: BOM example for AEM20940 and its required passive components

Note 1: patented circuit.

12 Layout

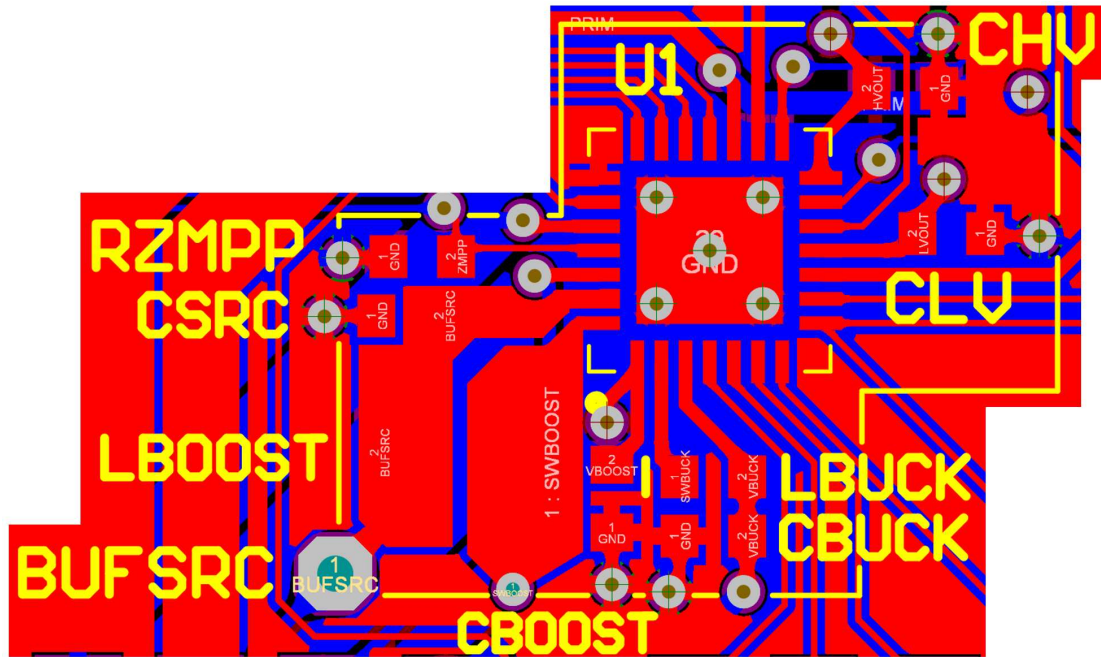

Figure 21: Layout example for the AEM20940 and its passive components

Note 2: Schematic, symbol and footprint for the e-peas component can be ordered by contacting the e-peas support team: support@e-peas.com

13 Package Information

13.1 Plastic quad flatpack no-lead (QFN28 5mm x 5mm)

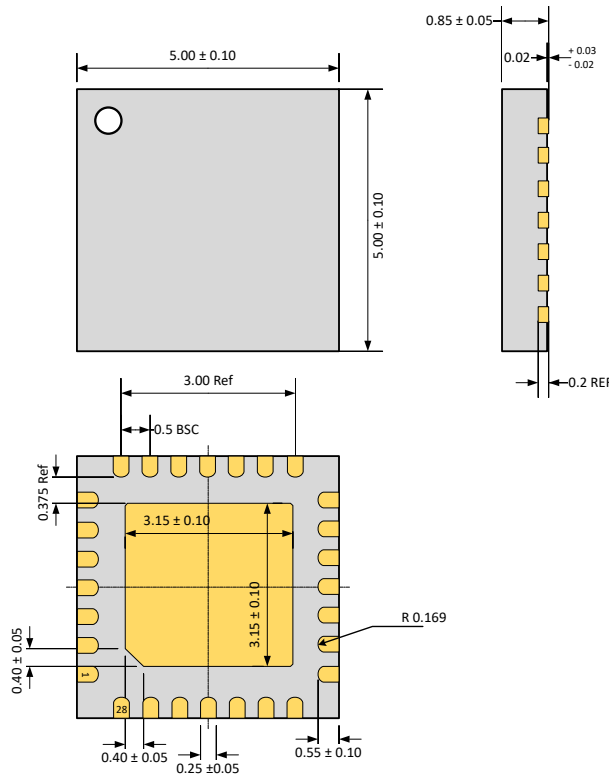

Figure 22: QFN28 5mm x 5mm

13.2 Board layout

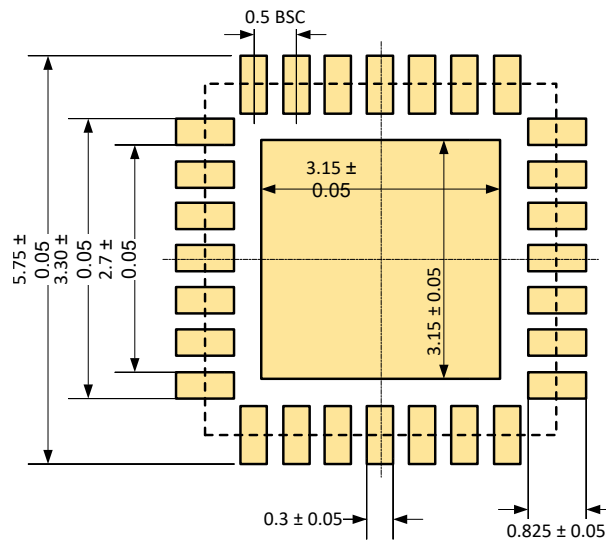

Figure 23: Board layout

Revision History

Revision	Date	Description
1.0	July, 2018	Creation of the document.
1.1	June, 2019	<ul style="list-style-type: none"> - p21, 22 → Updated efficiencies measurements; - p5 → ESD specifications; - p3 → HVOUT voltage on Figure 1 4.2V → 4.1V.
1.2	November, 2020	<ul style="list-style-type: none"> - p1 → 5 maximum VSRC values updated to 3.5V; - p3 → Figure 1: HVout 4.2V → 3.3V - p13 → Figure 6: CSIN and CSOUT shortcircuited - p5 → Adding ESD qualification - p4 → pin number of SELMPP[0] : 9 → 8 - p11 → CFG = 000 → Custom mode Reserved for future use - All → Cold start Coldstart → Cold start

X-ON Electronics

Largest Supplier of Electrical and Electronic Components

Click to view similar products for [Power Management Specialised - PMIC category](#):

Click to view products by [e-peas manufacturer](#):

Other Similar products are found below :

[LV5686PVC-XH](#) [FAN7710VN](#) [NCP391FCALT2G](#) [SLG7NT4081VTR](#) [SLG7NT4192VTR](#) [AP4313UKTR-G1](#) [AS3729B-BWLM](#)
[MB39C831QN-G-EFE2](#) [LV56841PVD-XH](#) [AP4306BUKTR-G1](#) [MIC5164YMM](#) [PT8A3252WE](#) [NCP392CSFCCT1G](#) [PT8A3284WE](#)
[PI3VST01ZEEX](#) [XRP7724ILB-1015-F](#) [PI5USB1458AZAEX](#) [PI5USB1468AZAEX](#) [TCKE712BNL,RF](#) [ISL91211AIKZT7AR5874](#)
[ISL91211BIKZT7AR5878](#) [ISL91212AIIZ-TR5770](#) [ISL91212BIIZ-TR5775](#) [CPX200D](#) [AX-3005D-3](#) [TP-1303](#) [TP-1305](#) [TP-1603](#) [TP-2305](#)
[TP-30102](#) [TP-4503N](#) [MIC5167YML-TR](#) [LR745N8-G](#) [STLUX383A](#) [TP-60052](#) [LM26480SQ-AA/NOPB](#) [LM81BIMTX-3/NOPB](#)
[LM81CIMT-3/NOPB](#) [MIC5166YML-TR](#) [GPS-2303](#) [GPS-3303](#) [GPS-4303](#) [TPS65920A2ZCHR](#) [MB39C811QN-G-EFE2](#) [MAX881REUB+](#)
[NCV7680PWR2G](#) [UAA2016PG](#) [LTC2926CUFD#PBF](#) [L6718](#) [MAX4069AUB+](#)