

## Highly-efficient, regulated dual-output, ambient energy manager for AC or DC sources with optional primary battery

### Features

#### Ultra-low-power start-up:

- Cold start from 380 mV input voltage and 3 μW input power (typical)
- RF input power from -19 dBm up to 10 dBm (typical)

#### Ultra-low-power boost regulator:

- Open-circuit voltage sensing for MPPT every 0.33 s
- Configurable MPPT with 2-pin programming
- Selectable Voc ratios of 50, 65 or 80 %
- Input voltage operation range from 50 mV to 5 V
- MPPT voltage operation range from 50 mV to 5 V
- Constant impedance matching (ZMPPT)

#### Integrated 1.2/1.8 V LDO regulator:

- Up to 20 mA load current
- Power gated dynamically by external control
- Selectable output voltage

#### Integrated 1.8 V-4.1 V LDO regulator:

- Up to 80 mA load current with 300 mV drop-out
- Power gated dynamically by external control
- Selectable or adjustable output voltage

#### Flexible energy storage management:

- Selectable overcharge and overdischarge protection for any type of rechargeable battery or (super)capacitor
- Fast supercapacitor charging
- Warns the load when battery is running low
- Warns when output voltage regulators are available

#### Optional primary battery:

- Automatically switches to the primary battery when the secondary battery is exhausted

#### Integrated balun for dual-cell supercapacitor

### Applications

- Piezo harvesting
- Micro turbine harvesting
- RF harvesting
- Industrial monitoring
- Home automation
- Transportation
- Smart agriculture

### Description

The AEM30940 is an integrated energy management circuit that extracts DC power from a piezo generator, a micro turbine generator or any high frequency RF input to simultaneously store energy in a rechargeable element and supply the system with two independent regulated voltages. The AEM30940 allows to extend battery lifetime and ultimately eliminates the primary energy storage element in a large range of wireless applications such as industrial monitoring, home automation, transportation and smart agriculture.

The AEM30940 harvests the available input current up to 110 mA. It integrates an ultra-low power boost converter to charge a storage element, such as a Li-ion battery, a thin film battery, a supercapacitor or a conventional capacitor. The boost converter operates with input voltages in a range from 50 mV to 5 V. With its unique cold-start circuit, it can start operating with empty storage elements at an input voltage as low as 380 mV and an input power of just 3 μW.

The low-voltage supply typically drives a microcontroller at 1.2 V or 1.8 V. The high-voltage supply typically drives a radio transceiver at a configurable voltage between 1.8 V and 4.1 V. Both are driven by highly-efficient LDO (Low Drop-Out) regulators for low noise and high stability.

Configuration pins determine various operating modes by setting predefined conditions for the energy storage element (overcharge or overdischarge voltages), and by selecting the voltage of the high-voltage supply and the low-voltage supply. Moreover, special modes can be obtained at the expense of a few configuration resistors.

The chip integrates all the active elements for powering a typical wireless sensor. Five capacitors and two inductors are required, available in the small 0402 and 0603 size, respectively. With only seven external components, integration is maximum, footprint and BOM are minimum, optimizing the time-to-market and the costs of WSN designs.

### Device information

Part number	Package	Body size
10AEM30940C0000	QFN 28-pin	5 mm x 5 mm

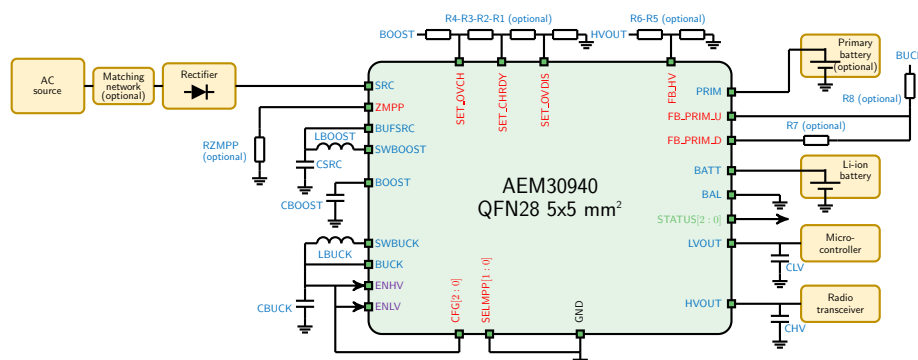

**Contents**

<b>1</b>	<b>Introduction</b>	<b>3</b>
<b>2</b>	<b>Absolute Maximum Ratings</b>	<b>5</b>
<b>3</b>	<b>Thermal Resistance</b>	<b>5</b>
<b>4</b>	<b>Typical Electrical Characteristics at 25 °C</b>	<b>5</b>
<b>5</b>	<b>Recommended Operation Conditions</b>	<b>6</b>
<b>6</b>	<b>Functional Block Diagram</b>	<b>7</b>
<b>7</b>	<b>Theory of Operation</b>	<b>8</b>
7.1	Deep sleep & Wake up modes . . . . .	8
7.2	Normal mode . . . . .	9
7.3	Overvoltage mode . . . . .	9
7.4	Primary mode . . . . .	10
7.5	Shutdown mode . . . . .	10
7.6	Maximum power point tracking . . . . .	10
7.7	Balun for dual-cell supercapacitor . . . . .	10
<b>8</b>	<b>System Configuration</b>	<b>11</b>
8.1	Battery and LDOs configuration . . . . .	11
8.2	MPPT configuration . . . . .	12
8.3	Primary battery configuration . . . . .	12
8.4	ZMPPT configuration . . . . .	12
8.5	No-battery configuration . . . . .	12
8.6	Storage element information . . . . .	12
<b>9</b>	<b>Typical Application Circuits</b>	<b>13</b>
9.1	Example circuit 1 . . . . .	13
9.2	Example circuit 2 . . . . .	14
<b>10</b>	<b>Performance Data</b>	<b>18</b>
10.1	BOOST conversion efficiency . . . . .	18
10.2	Quiescent current . . . . .	18
10.3	High-voltage LDO regulation . . . . .	19
10.4	Low-voltage LDO regulation . . . . .	19
10.5	High-voltage LDO efficiency . . . . .	20
10.6	Low-voltage LDO efficiency . . . . .	20
10.7	RF path efficiency . . . . .	21
10.8	Overall efficiency . . . . .	22
<b>11</b>	<b>Schematic</b>	<b>23</b>
<b>12</b>	<b>Layout</b>	<b>24</b>
<b>13</b>	<b>Package Information</b>	<b>25</b>
13.1	Plastic quad flatpack no-lead (QFN28 5x5mm) . . . . .	25
13.2	Board layout . . . . .	25

**List of Figures**

<b>1</b>	Simplified schematic view . . . . .	<b>3</b>
<b>2</b>	Pinout diagram QFN28 . . . . .	<b>4</b>
<b>3</b>	Functional block diagram . . . . .	<b>7</b>
<b>4</b>	Simplified schematic view of the AEM30940 . . . . .	<b>8</b>
<b>5</b>	Diagram of the AEM30940 modes . . . . .	<b>8</b>
<b>6</b>	Custom configuration resistors . . . . .	<b>11</b>
<b>7</b>	Typical application circuit 1 . . . . .	<b>13</b>
<b>8</b>	Typical application circuit 2 . . . . .	<b>14</b>
<b>9</b>	Cold start with a capacitor connected to BATT . . . . .	<b>15</b>
<b>10</b>	Cold start with a battery connected to BATT . . . . .	<b>15</b>
<b>11</b>	Overvoltage mode . . . . .	<b>16</b>
<b>12</b>	Shutdown mode (without primary battery) . . . . .	<b>16</b>
<b>13</b>	Switch to primary battery if the battery is overdischarged . . . . .	<b>17</b>
<b>14</b>	Boost efficiency for Isrc at 100 $\mu$ A, 1 mA, 10 mA and 100 mA . . . . .	<b>18</b>
<b>15</b>	Quiescent current with LDOs on and off . . . . .	<b>18</b>
<b>16</b>	HVOUT at 3.3 V and 2.5 V . . . . .	<b>19</b>
<b>17</b>	LVOUT at 1.2 V and 1.8 V . . . . .	<b>19</b>
<b>18</b>	HVOUT efficiency at 1.8 V, 2.5 V and 3.3 V . . . . .	<b>20</b>
<b>19</b>	Efficiency of BUCK cascaded with LVOUT at 1.2 V and 1.8 V . . . . .	<b>20</b>
<b>20</b>	Efficiency for 863-868 MHz band . . . . .	<b>21</b>
<b>21</b>	Efficiency for 915-921 MHz band . . . . .	<b>21</b>
<b>22</b>	Overall efficiency (RF path and boost converter) with VBOOST = 3.5 V . . . . .	<b>22</b>
<b>23</b>	Schematic example . . . . .	<b>23</b>
<b>24</b>	Layout example for the AEM30940 and its passive components . . . . .	<b>24</b>
<b>25</b>	QFN28 5x5mm . . . . .	<b>25</b>
<b>26</b>	Board layout . . . . .	<b>25</b>

**List of Tables**

<b>1</b>	Pins description . . . . .	<b>4</b>
<b>2</b>	Absolute maximum ratings . . . . .	<b>5</b>
<b>3</b>	Thermal data . . . . .	<b>5</b>
<b>4</b>	Electrical characteristics . . . . .	<b>5</b>
<b>5</b>	Recommended operating conditions . . . . .	<b>6</b>
<b>6</b>	Minimum input power for the cold start (typical). Results obtained with the matching network and rectifier designed by e-peas . . . . .	<b>8</b>
<b>7</b>	LDOs configurations . . . . .	<b>9</b>
<b>8</b>	Usage of CFG[2:0] . . . . .	<b>11</b>
<b>9</b>	Usage of SELMPP[1:0] . . . . .	<b>12</b>
<b>10</b>	BOM example for AEM30940 and its required passive components . . . . .	<b>23</b>

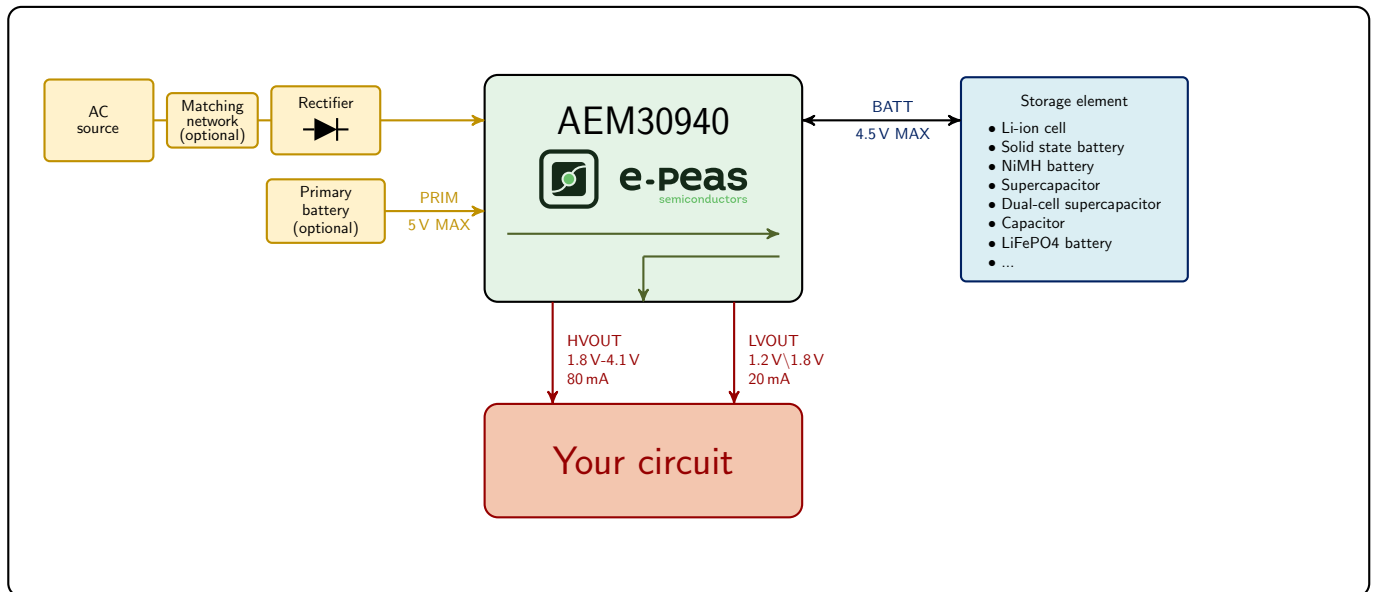

Figure 1: Simplified schematic view

## 1 Introduction

The AEM30940 is a full-featured energy efficient power management circuit able to charge a storage element (battery or supercapacitor, connected to **BATT**) from an energy source (connected to **SRC**) as well as to supply loads at different operating voltages through two power supplying LDO regulators (**LVOUT** and **HVOUT**).

The heart of the AEM30940 is a cascade of two regulated switching converters, namely the boost converter and the buck converter with high-power conversion efficiencies (See Page 18).

At first start-up, as soon as a required cold-start voltage of 380 mV and a scant amount of power of just 3  $\mu$ W available from the harvested energy source, the AEM coldstarts. After the cold start, the AEM can extract the power available from the source as long as the input voltage is comprised between 50 mV and 5 V.

Through three configuration pins (**CFG[2:0]**), the user can select a specific operating mode from a range of seven modes that cover most application requirements without any dedicated external component. Those operating modes define the LDO output voltages and the protection levels of the storage element. Note that a custom mode allows the user to define his own storage element protection levels and the output voltage of the high-voltage LDO (See Page 11).

The Maximum Power Point (MPP) ratio can be configured using two configuration pins (**SELMPP[1:0]**) (See Page 12).

Two logic control pins are provided (**ENLV** and **ENHV**) to dynamically activate or deactivate the LDO regulators that supply the low- and high-voltage load, respectively. The status pin **STATUS[0]** alerts the user that the LDOs are operational and can be enabled. This signal can also be used to enable an optional external regulator.

If the battery voltage gets depleted, the LDOs are power gated and the controller is no longer supplied by the storage element to protect it from further discharge. Around 600 ms before the shutdown of the AEM, the status pin **STATUS[1]** alerts the user for a clean shutdown of the system.

However, if the storage element gets depleted and an optional primary battery is connected on **PRIM**, the chip automatically uses it as a source to recharge the storage element before switching back to the ambient source. This guarantees continuous operation even under the most adverse conditions (See Page 10). **STATUS[1]** is asserted when the primary battery is providing power.

The status of the MPP controller is reported with one dedicated status pin (**STATUS[2]**). The status pin is asserted when a MPP calculation is being performed.

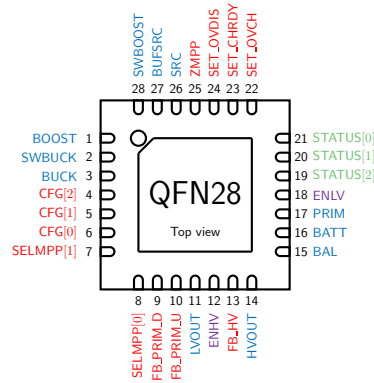

Figure 2: Pinout diagram QFN28

NAME	PIN NUMBER	FUNCTION	
<b>Power pins</b>			
BOOST	1	Output of the boost converter.	
SWBUCK	2	Switching node of the buck converter.	
BUCK	3	Output of the buck converter.	
LVOUT	11	Output of the low voltage LDO regulator.	
HVOUT	14	Output of the high voltage LDO regulator.	
BAL	15	Connection to mid-point of a dual-cell supercapacitor (optional). Must be connected to GND if not used.	
BATT	16	Connection to the energy storage element, battery or capacitor. Cannot be left floating.	
PRIM	17	Connection to the primary battery (optional). Must be connected to GND if not used.	
SRC	26	Connection to the harvested energy source.	
BUFSRC	27	Connection to an external capacitor buffering the boost converter input.	
SWBOOST	28	Switching node of the boost converter.	
<b>Configuration pins</b>			
CFG[2]	4	Used for the configuration of the threshold voltages for the energy storage element and the output voltage of the LDOs.	See Page 11
CFG[1]	5		
CFG[0]	6		
SELMPP[1]	7	Used for the configuration of the MPP ratio.	
SELMPP[0]	8		
FB_PRIM_D	9	Used for the configuration of the primary battery (optional). Must be connected to GND if not used.	
FB_PRIM_U	10		
FB_HV	13	Used for the configuration of the high-voltage LDO in the custom mode (optional). Must be left floating if not used.	
SET_OVCH	22	Used for the configuration of the threshold voltages for the energy storage element in the custom mode (optional). Must be left floating if not used.	
SET_CHRDY	23		
SET_OVDIS	24		
ZMPPT	25	Used for the configuration of the ZMPPT (optional). Must be left floating if not used.	
<b>Control pins</b>			
ENHV	12	Enabling pin for the high-voltage LDO.	See Page 9
ENLV	18	Enabling pin for the low-voltage LDO.	
<b>Status pins</b>			
STATUS[2]	19	Logic output. Asserted when the AEM performs a MPP evaluation.	See Pages 8-10
STATUS[1]	20	Logic output. Asserted if the battery voltage falls below <i>Vovdis</i> or if the AEM is taking energy from the primary battery.	
STATUS[0]	21	Logic output. Asserted when the LDOs can be enabled.	
<b>Other pins</b>			
GND	Exposed Pad	Ground connection, should be solidly tied to the PCB ground plane.	

Table 1: Pins description

## 2 Absolute Maximum Ratings

Parameter	Rating
V <sub>src</sub>	5.5 V
Operating junction temperature	-40 °C to +125 °C
Storage temperature	-65 °C to +150 °C

Table 2: Absolute maximum ratings

## 3 Thermal Resistance

Package	$\theta_{JA}$	$\theta_{JC}$	Unit
QFN28	38.3	2.183	°C/W

Table 3: Thermal data

### ESD CAUTION

	<b>ESD (ELECTROSTATIC DISCHARGE) SENSITIVE DEVICE</b> These devices have limited built-in ESD protection and damage may thus occur on devices subjected to high-energy ESD. Therefore, proper ESD precautions should be taken to avoid performance degradation or loss of functionality.	
	V <sub>ESD</sub>	Human-body model according to Jedec JS001-2017 ± 500 V Charge device model according to Jedec JS002-2014 ± 1000 V

## 4 Typical Electrical Characteristics at 25 °C

Symbol	Parameter	Conditions	Min	Typ	Max	Unit
<b>Input voltage and input power</b>						
P <sub>srcCS</sub>	Source power required for cold start.	During cold start	3			μW
V <sub>src</sub>	Input voltage of the energy source.	During cold start	0.38		5	V
		After cold start	0.05		5	
<b>DC-DC converters</b>						
V <sub>boost</sub>	Output of the boost converter.	During normal operation	2.2		4.5	V
V <sub>buck</sub>	Output of the buck converter.	During normal operation	2	2.2	2.5	
<b>Storage element</b>						
V <sub>batt</sub>	Voltage on the storage element.	Rechargeable battery	2.2		4.5	V
		Capacitor	0		4.5	V
T <sub>crit</sub>	Time before shutdown after STATUS[1] has been asserted.		400	600	800	ms
V <sub>prim</sub>	Voltage on the primary battery.		0.6		5	V
V <sub>fb_prim_u</sub>	Feedback for the minimal voltage level on the primary battery.		0.15		1.1	V
V <sub>ovch</sub>	Maximum voltage accepted on the storage element before disabling the boost converter.	see Table 8	2.3		4.5	V
V <sub>chrdy</sub>	Minimum voltage required on the storage element before enabling the LDOs after a cold start.	see Table 8	2.25		4.45	V
V <sub>ovdis</sub>	Minimum voltage accepted on the storage element before switching to primary battery or entering into a shutdown.	see Table 8	2.2		4.4	V
<b>Low-voltage LDO regulator</b>						
V <sub>lv</sub>	Output voltage of the low-voltage LDO.	see Table 8	1.2		1.8	V
I <sub>lv</sub>	Load current from the low-voltage LDO.		0		20	mA
<b>High-voltage LDO regulator</b>						
V <sub>hv</sub>	Output voltage of the high-voltage LDO.	see Table 8	1.8		V <sub>batt</sub> - 0.3	V
I <sub>hv</sub>	Load current from the high-voltage LDO.		0		80	mA
<b>Logic output pins</b>						
STATUS[2:0]	Logic output levels on the status pins.	Logic high (VOH)	1.98	V <sub>batt</sub>		V
		Logic low (VOL)	-0.1		0.1	V

Table 4: Electrical characteristics

## 5 Recommended Operation Conditions

Symbol	Parameter	Min	Typ	Max	Unit	
<b>External components</b>						
CSRC	Capacitor decoupling the <b>BUFSRC</b> pin.	8	10	22	$\mu\text{F}$	
CBOOST	Capacitor of the boost converter.	10	22	25	$\mu\text{F}$	
LBOOST	Inductor of the boost converter.	4	10	25	$\mu\text{H}$	
CBUCK	Capacitor of the buck converter.	8	10	22	$\mu\text{F}$	
LBUCK	Inductor of the buck converter.	4	10	25	$\mu\text{H}$	
CLV	Capacitor decoupling the low-voltage LDO regulator.	8	10	14	$\mu\text{F}$	
CHV	Capacitor decoupling the high-voltage LDO regulator.	8	10	14	$\mu\text{F}$	
CBATT	<b>Optional</b> - Capacitor on BATT if no storage element is connected (see Page 12).	150			$\mu\text{F}$	
RT	<b>Optional</b> - Resistor for setting threshold voltage of the battery in custom mode. Equal to $R1 + R2 + R3 + R4$ (see Page 11).	1	10	100	$\text{M}\Omega$	
RV	<b>Optional</b> - Resistor for setting the output voltage of the high-voltage LDO in custom mode. Equal to $R5 + R6$ (see Page 11)	1	10	40	$\text{M}\Omega$	
RZMPP	<b>Optional</b> - Resistor for the ZMPPT configuration (see Page 12).	10		1M	$\Omega$	
RP	<b>Optional</b> - Resistor to be used with a primary battery. Equal to $R7 + R8$ (see Page 12).	100		500	$\text{k}\Omega$	
<b>Logic input pins</b>						
ENHV	Enabling pin for the high-voltage LDO <sup>1</sup> .	Logic high (VOH)	1.75	V <sub>buck</sub>	V <sub>buck</sub>	V
		Logic low (VOL)	-0.01	0	0.01	
ENLV	Enabling pin for the low-voltage LDO <sup>2</sup> .	Logic high (VOH)	1.75	V <sub>buck</sub>	V <sub>boost</sub>	V
		Logic low (VOL)	-0.01	0	0.01	
SELMPP[1:0]	Configuration pins for the MPP evaluation (see Table 9).	Logic high (VOH)	Connect to <b>BUCK</b>			
		Logic low (VOL)	Connect to <b>GND</b>			
CFG[2:0]	Configuration pins for the storage element (see Table 8).	Logic high (VOH)	Connect to <b>BUCK</b>			
		Logic low (VOL)	Connect to <b>GND</b>			
STONBATT	Configuration pin to select the energy source during the cold start.	Logic high (VOH)	Connect to <b>BATT</b>			
		Logic low (VOL)	Connect to <b>GND</b>			

Table 5: Recommended operating conditions

Note 1: **ENHV** can be dynamically driven by a logic signal from the LV domain. For a static usage, connect to **BUCK** (High) or **GND** (Low).

Note 2: **ENLV** can be dynamically driven by a logic signal from the HV domain. For a static usage, connect to **BUCK** or **BOOST** (High) or **GND** (Low).

## 6 Functional Block Diagram

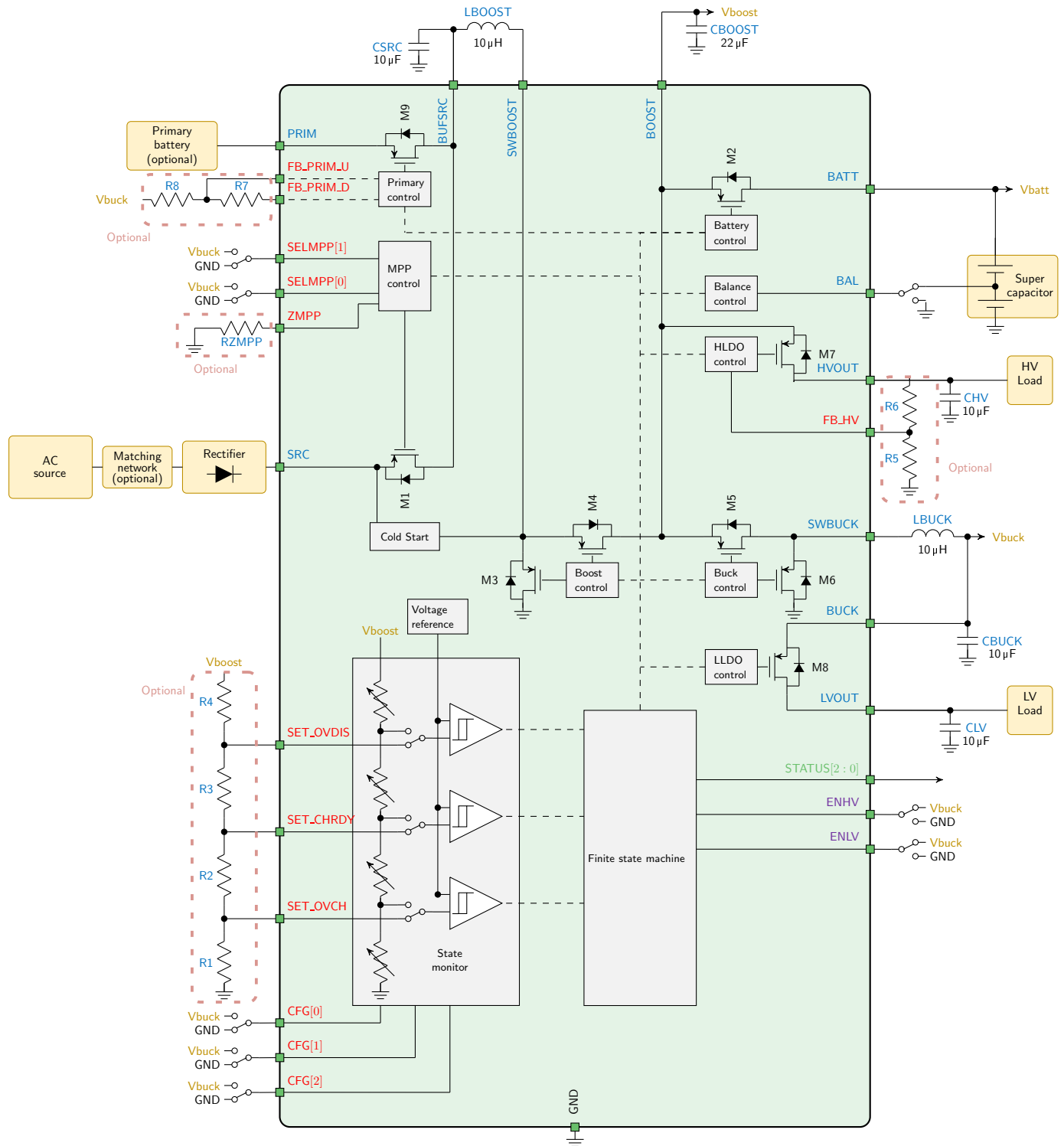

Figure 3: Functional block diagram

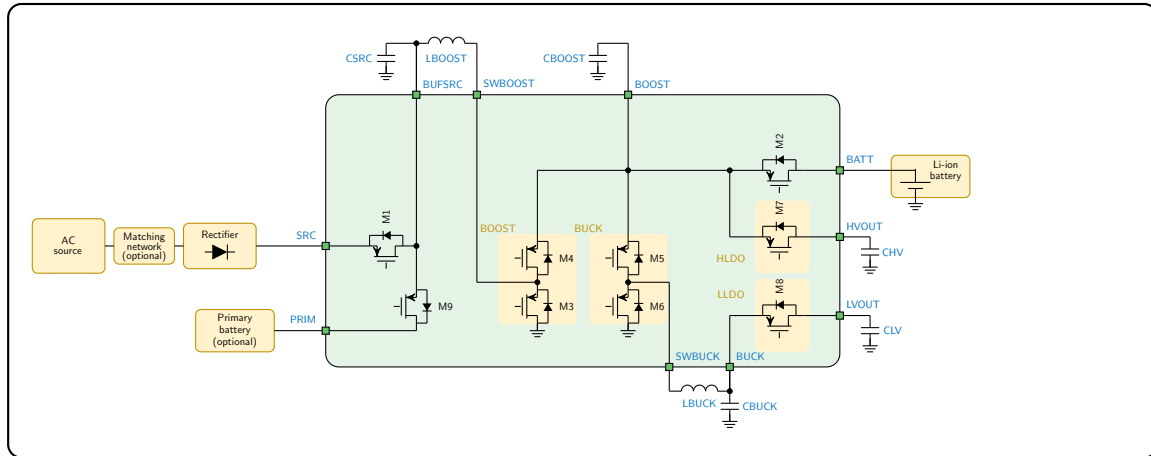

Figure 4: Simplified schematic view of the AEM30940

## 7 Theory of Operation

### 7.1 Deep sleep & Wake up modes

The **DEEP SLEEP MODE** is a state where all nodes are deeply discharged and there is no available energy to be harvested. As soon as the required cold-start voltage of 380 mV and a sparse amount of power of just 3  $\mu$ W becomes available on **SRC**, the **WAKE UP MODE** is activated. For RF source, the input power at the antenna is defined by the matching network and rectifier associater. See the Table 6 for e-peas results. **Vboost** and **Vbuck** rises up to a voltage of 2.2 V. **Vboost** then rises alone up to **Vovch**.

At that stage, both LDOs are internally deactivated. Therefore, **STATUS[0]** is equal to 0 as shown in Figure 9 and Figure 10.

When **Vboost** reaches **Vovch**, two scenarios are possible: in the first scenario, a super-capacitor or a capacitor having a voltage lower than **Vchrdy** is connected to the **BATT** node. In the second scenario, a charged battery is connected to the **BATT** node.

Frequency [MHz]	Pin [dBm]	Pin [ $\mu$ W]
863-868	-19	12.5
915-921	-19	12.5

Table 6: Minimum input power for the cold start (typical). Results obtained with the matching network and rectifier designed by e-peas

### Supercapacitor as a storage element

If the storage element is a supercapacitor, the storage element may need to be charged from 0 V. The boost converter charges **BATT** from the input source and by modulating the conductance of M2. During the charge of the **BATT** node, both

LDOs are deactivated and **STATUS[0]** is de-asserted. When **Vbatt** reaches **Vchrdy**, the circuit enters **NORMAL MODE**, **STATUS[0]** is asserted and the LDOs can be activated by the user using the **ENLV** and **ENHV** control pins as shown in Figure 9.

### Battery as a storage element

If the storage element is a battery, but its voltage is lower than **Vchrdy**, then the storage element first needs to be charged until it reaches **Vchrdy**. Once **Vbatt** exceeds **Vchrdy**, or if the battery was initially charged above **Vchrdy**, the circuit enters **NORMAL MODE**. **STATUS[0]** is asserted and the LDOs can be activated by the user thanks to **ENLV** and **ENHV** as shown in Figure 10.

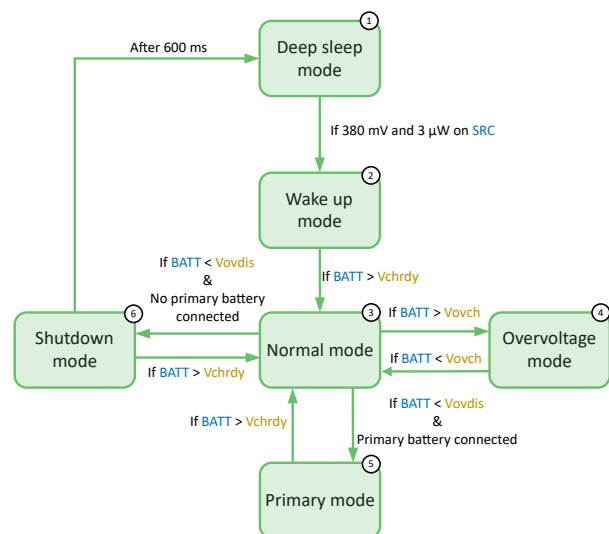

Figure 5: Diagram of the AEM30940 modes



## 7.2 Normal mode

Once the AEM enters **NORMAL MODE**, three scenarios are possible:

- There is enough power provided by the source to maintain  $V_{batt}$  above  $V_{ovdis}$  but  $V_{batt}$  is below  $V_{ovch}$ . In that case, the circuit remains **NORMAL MODE**.
- The source provides more power than the load consumes, and  $V_{batt}$  increases above  $V_{ovch}$ , the circuit enters into the **OVERVOLTAGE MODE**, as explained in the **Overvoltage mode** section.
- Due to a lack of power from the source,  $V_{batt}$  falls below  $V_{ovdis}$ . In this case, either the circuit enters **SHUTDOWN MODE** as explained in **Shutdown mode** section or, if a charged primary battery is connected on **PRIM**, the circuit enters **PRIMARY MODE** as explained in the **Primary mode** section.

### Matching network and rectifier

To connect AC sources to the AEM30940, an external rectifier is required as well as a matching network in the case of RF energy harvesting. The objective of the matching network is to modify the impedance relationship between the RF source and the rectifier in order to optimize the power transfer over a frequency band and an input power range. For RF applications, external high frequency rectifiers as well as matching networks are available <sup>1</sup> for the following RF bands: 828 MHz, 915 MHz.

### Boost

The boost (or step-up) converter raises the voltage available at **BUFSRC** to a level suitable for charging the storage element, in the range of 2.2 V to 4.5 V, according to the system configuration. This voltage ( $V_{boost}$ ) is available at the **BOOST** pin. The switching transistors of the boost converter are M3 and M4, with the switching node available externally at **SWBOOST**. The reactive power components of this converter are the external inductor and capacitor **LBOOST** and **CBOOST**. Periodically, the MPP control circuit disconnects the source from the **BUFSRC** pin with the transistor M1 in order to measure the open-circuit voltage of the harvester on **SRC** and define the optimal level of voltage. **BUFSRC** is decoupled by the capacitor **CSRC**, which smooths the voltage against the current pulses induced by the boost converter.

The storage element is connected to the **BATT** pin, at a voltage  $V_{batt}$ . This node is linked to **BOOST** through the transistor M2. In **NORMAL MODE**, this transistor effectively shorts the battery to the **BOOST** node ( $V_{batt} = V_{boost}$ ). When energy harvesting is occurring, the boost converter delivers a current that is shared between the battery and the loads. M2 is opened to disconnect the storage element when  $V_{batt}$  reaches  $V_{ovdis}$ . However, in such a scenario, the AEM30940 offers the possibility of connecting a primary battery to recharge  $V_{batt}$  up to the  $V_{chrdy}$ . The transistor M9 connects **PRIM** to **BUFSRC** and the transistor M1 is opened to disconnect the **SRC** input pin as explained in the **Primary mode** section and shown in Figure 13.

**Buck**

The buck (or step-down) converter lowers the voltage from  $V_{boost}$  to a constant  $V_{buck}$  value of 2.2 V. This voltage is available at the **BUCK** pin. The switching transistors of the buck converter are M5 and M6, with the switching node available externally at **SWBUCK**. The reactive power components of the buck converter are the external inductor **LBUCK** and the capacitor **CBUCK**.

### LDO outputs

Two LDOs are available to supply loads at different operating voltages:

Through M7,  $V_{boost}$  supplies the high-voltage LDO that powers its load through **HVOUT**. This regulator delivers a clean voltage ( $V_{hv}$ ) with a maximum current of 80 mA on **HVOUT**. In the built-in configuration modes, an output voltage of 1.8 V, 2.5 V or 3.3 V can be selected. In the custom configuration mode, it is adjustable between 2.2 V and  $V_{batt}-0.3$  V. The high-voltage output can be dynamically enabled or disabled with the logic control pin **ENHV**. The output is decoupled by the external capacitor **CHV**.

Through M8,  $V_{buck}$  supplies the low-voltage LDO that powers its load through **LVOUT**. This regulator delivers a clean voltage ( $V_{lv}$ ) of 1.8 V or 1.2 V with a maximum current of 20 mA on **LVOUT**. The low-voltage output can be dynamically enabled or disabled with the logic control pin **ENLV**. The output is decoupled by the external capacitor **CLV**.

Status pin **STATUS[0]** alerts the user when the LDOs can be enabled as explained in the **Deep sleep & Wake up modes** section and in the **Shutdown mode** section. The table below shows the four possible configurations:

### LDO outputs

Two LDOs are available to supply loads at different operating voltages:

Through M7,  $V_{boost}$  supplies the high-voltage LDO that powers its load through **HVOUT**. This regulator delivers a clean voltage ( $V_{hv}$ ) with a maximum current of 80 mA on **HVOUT**. In the built-in configuration modes, an output voltage of 1.8 V, 2.5 V or 3.3 V can be selected. In the custom configuration mode, it is adjustable between 2.2 V and  $V_{batt}-0.3$  V. The high-voltage output can be dynamically enabled or disabled with the logic control pin **ENHV**. The output is decoupled by the external capacitor **CHV**.

Through M8,  $V_{buck}$  supplies the low-voltage LDO that powers its load through **LVOUT**. This regulator delivers a clean voltage ( $V_{lv}$ ) of 1.8 V or 1.2 V with a maximum current of 20 mA on **LVOUT**. The low-voltage output can be dynamically enabled or disabled with the logic control pin **ENLV**. The output is decoupled by the external capacitor **CLV**.

Status pin **STATUS[0]** alerts the user when the LDOs can be enabled as explained in the **Deep sleep & Wake up modes** section and in the **Shutdown mode** section. The table below shows the four possible configurations:

ENLV	ENHV	LV output	HV output
1	1	Enabled	Enabled
1	0	Enabled	Disabled
0	1	Disabled	Enabled
0	0	Disabled	Disabled

Table 7: LDOs configurations

## 7.3 Overvoltage mode

When  $V_{batt}$  reaches  $V_{ovch}$ , the charge is complete and the internal logic maintains  $V_{batt}$  around  $V_{ovch}$  with a hysteresis of a few mV as shown in Figure 11 to prevent damage to the storage element and to the internal circuitry. In this configuration, the boost converter is periodically activated to maintain  $V_{batt}$  and the LDOs are still available. Moreover, when the boost converter is not activated, the transistor M1 in Figure 4 is opened to prevent current from the source to the storage element when  $V_{src}$  is higher than  $V_{ovch}$ .

<sup>1</sup>Contact support@e-peas.com for additional information

## 7.4 Primary mode

When  $V_{batt}$  drops below  $V_{ovdis}$ , the circuit compares the voltage on  $PRIM$  with the voltage on  $FB\_PRIM\_U$  to determine whether a charged primary battery is connected on  $PRIM$ . The voltage on  $FB\_PRIM\_U$  is set thanks to two optional resistances as explained in the [Primary battery configuration](#) section. If the voltage on  $PRIM$  divided by 4 is higher than the voltage on  $FB\_PRIM\_U$ , the circuit considers the primary battery as available and the circuit enters **PRIMARY MODE** as shown in Figure 13.

In that mode, transistor M1 is opened and the primary battery is connected to  $BUFSRC$  through transistor M9 to become the source of energy for the AEM30940. The chip remains in this mode until  $V_{batt}$  reaches  $V_{chrdy}$ . When  $V_{batt}$  reaches  $V_{chrdy}$ , the circuit enters **NORMAL MODE**. As long as the chip is in **PRIMARY MODE**,  $STATUS[1]$  is asserted.

If no primary battery is used in the application,  $PRIM$ ,  $FB\_PRIM\_U$  and  $FB\_PRIM\_D$  must be tied to GND.

## 7.5 Shutdown mode

When  $V_{batt}$  drops below  $V_{ovdis}$  and no power is available from a primary battery, the circuit enters **SHUTDOWN MODE** as shown in Figure 12 to prevent deep discharge potentially leading to damage to the storage element and instability of the LDOs. The circuit asserts  $STATUS[1]$  to warn the system that a shutdown will occur. Both LDO regulators remain enabled. If no primary battery is used, this allows the load, whether it is powered on  $LVOUT$  or  $HVOUT$ , to be interrupted by the low-to-high transition of  $STATUS[1]$ , and to take all appropriate actions before power shutdown.

If energy at the input source is available and  $V_{batt}$  recovers to  $V_{chrdy}$  within  $T_{crit}$  ( $\sim 600$  ms), the AEM returns in **NORMAL MODE**. But if, after  $T_{crit}$ ,  $V_{batt}$  does not reach  $V_{chrdy}$ , the circuit enters **DEEP SLEEP MODE**. The LDOs are deactivated and  $BATT$  is disconnected from  $BOOST$  to avoid damaging the battery due to the overdischarge. From now, the AEM will have to go through the wake-up procedure described in the [Deep sleep & Wake up modes](#) section.

## 7.6 Maximum power point tracking

During **NORMAL MODE**, **SHUTDOWN MODE** and a part of **WAKE UP MODE**, the boost converter is regulated thanks to

an internal MPPT (Maximum Power Point Tracking) module.  $V_{mpp}$  is the voltage level of the MPP, and depends on the input power available at the source. The MPPT module evaluates  $V_{mpp}$  as a given fraction of  $V_{oc}$ , the open-circuit voltage of the source. By temporarily disconnecting the source from  $CSRC$  as shown in Figure 4 for 5.12 ms, the MPPT module receives from and maintains knowledge of  $V_{mpp}$ . This sampling occurs approximatively every 0.33 s.

With the exception of this sampling process, the voltage across the source,  $V_{src}$ , is continuously compared to  $V_{mpp}$ . When  $V_{src}$  exceeds  $V_{mpp}$  by a small hysteresis, the boost converter is switched on, extracting electrical charges from the source and lowering its voltage. When  $V_{src}$  falls below  $V_{mpp}$  by a small hysteresis, the boost converter is switched off, allowing the harvester to accumulate new electrical charges into  $CSRC$ , which restores its voltage. In this manner, the boost converter regulates its input voltage so that the electrical current (or flow of electrical charges) that enters the boost converter yields the best power transfer from the harvester under any ambient conditions. The AEM30940 supports any  $V_{mpp}$  level in the range from 0.05 V to 5 V. It offers a choice of four values for the  $V_{mpp}/V_{oc}$  fraction or to match the input impedance of the BOOST converter with an impedance connected to the ZMPP terminal through configuration pins  $SELMPP[1:0]$  as shown in Table 9. The status of the MPPT controller is reported through one dedicated status pins ( $STATUS[2]$ ). The status pin is asserted when a MPP calculation is being performed.

## 7.7 Balun for dual-cell supercapacitor

The balun circuit allows users to balance the internal voltage in a dual-cell supercapacitor in order to avoid damaging the super-capacitor because of excessive voltage on one cell. If  $BAL$  is connected to GND, the balun circuit is disabled. This configuration must be used if a battery, a capacitor or a single-cell supercapacitor is connected on  $BATT$ . If  $BAL$  is connected to the node between the cells of a supercapacitor, the balun circuit compensates for any mismatch of the two cells that could lead to over-charge of one of both cells. The balun circuit ensures that  $BAL$  remains close to  $V_{batt}/2$ . This configuration must be used if a dual-cell supercapacitor is connected on  $BATT$ .

## 8 System Configuration

Configuration pins			Storage element threshold voltages			LDOs output voltages		Typical use
CFG[2]	CFG[1]	CFG[0]	Vovch	Vchrdy	Vovdis	Vhv	Vlv	
1	1	1	4.12 V	3.67 V	3.60 V	3.3 V	1.8 V	Li-ion battery
1	1	0	4.12 V	4.04 V	3.60 V	3.3 V	1.8 V	Solid state battery
1	0	1	4.12 V	3.67 V	3.01 V	2.5 V	1.8 V	Li-ion/NiMH battery
1	0	0	2.70 V	2.30 V	2.20 V	1.8 V	1.2 V	Single-cell supercapacitor
0	1	1	4.50 V	3.67 V	2.80 V	2.5 V	1.8 V	Dual-cell supercapacitor
0	1	0	4.50 V	3.92 V	3.60 V	3.3 V	1.8 V	Dual-cell supercapacitor
0	0	1	3.63 V	3.10 V	2.80 V	2.5 V	1.8 V	LiFePO4 battery
0	0	0	Custom mode - Programmable through R1 to R6				1.8 V	

Table 8: Usage of CFG[2:0]

### 8.1 Battery and LDOs configuration

Through three configuration pins (CFG[2:0]), the user can set a particular operating mode from a range that covers most application requirements, without any dedicated external component as shown in Table 8. The three threshold levels are defined as:

- **Vovch** : Maximum voltage accepted on the storage element before disabling the boost converter,
- **Vchrdy** : Minimum voltage required on the storage element after a cold start before enabling the LDOs,
- **Vovdis** : Minimum voltage accepted on the storage element before considering the storage element as depleted.

See [Theory of Operation](#) section for more information about the purposes of these thresholds.

The two LDOs output voltages are called **Vhv** and **Vlv** for the high- and low-output voltages, respectively. In the built-in configuration mode, seven combinations of these voltage levels are hardwired and selectable through the CFG[2:0] configuration pins, covering most application cases. When a predefined configuration is selected, the resistor pins dedicated to a custom configuration should be left floating (SET\_OVDIS, SET\_CHRDY, SET\_OVCH, FB\_HV).

A custom mode allows the user to define the **Vovch**, **Vchrdy**, **Vovdis** and **Vhv** threshold voltages.

#### Custom mode

When CFG[2:0] are tied to GND, the custom mode is selected and all six configuration resistors shown in Figure 6, must be wired as follows:

**Vovch**, **Vchrdy** and **Vovdis** are defined thanks to R1, R2, R3 and R4. If we define the total resistor ( $R1 + R2 + R3 + R4$ ) as  $RT$ , R1, R2, R3 and R4 are calculated as:

- $1\text{ M}\Omega \leq RT \leq 100\text{ M}\Omega$
- $R1 = RT(1\text{ V}/Vovch)$

- $R2 = RT(1\text{ V}/Vchrdy - 1\text{ V}/Vovch)$

- $R3 = RT(1\text{ V}/Vovdis - 1\text{ V}/Vchrdy)$

- $R4 = RT(1 - 1\text{ V}/Vovdis)$

**Vhv** is defined thanks to R5 and R6. If we define the total resistor ( $R5 + R6$ ) as  $RV$ , R5 and R6 are calculated as:

- $1\text{ M}\Omega \leq RV \leq 40\text{ M}\Omega$

- $R5 = RV(1\text{ V}/Vhv)$

- $R6 = RV(1 - 1\text{ V}/Vhv)$

The resistors should have high values to make the additional power consumption negligible. Moreover, the following constraints must be adhered to ensure the functionality of the chip:

- $Vchrdy + 0.05\text{ V} \leq Vovch \leq 4.5\text{ V}$

- $Vovdis + 0.05\text{ V} \leq Vchrdy \leq Vovch - 0.05\text{ V}$

- $2.2\text{ V} \leq Vovdis$

- $Vhv \leq Vovdis - 0.3\text{ V}$

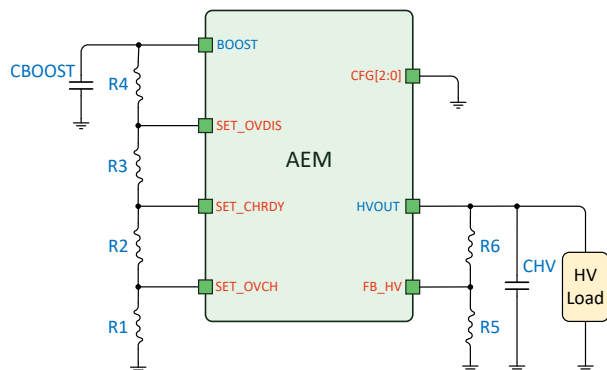

Figure 6: Custom configuration resistors

## 8.2 MPPT configuration

Two dedicated configuration pins, **SELMPP[1:0]**, allow selecting the MPP tracking ratio based on the characteristic of the input power source.

SELMPP[1]	SELMPP[0]	V <sub>mpp</sub> /V <sub>oc</sub>
0	0	50 %
0	1	65 %
1	0	80 %
1	1	ZMPP

Table 9: Usage of **SELMPP[1:0]**

## 8.3 Primary battery configuration

To use the primary battery, it is mandatory to determine **V<sub>prim\_min</sub>**, the voltage of the primary battery at which it has to be considered as empty. During the evaluation of **V<sub>prim\_min</sub>**, the circuit connects **FB\_PRIM\_D** to GND. The circuit uses a resistive divider between **BUCK** and **FB\_PRIM\_D** to define the voltage on **FB\_PRIM\_U** as **V<sub>prim\_min</sub>** divided by 4. When **V<sub>prim\_min</sub>** is not evaluated, **FB\_PRIM\_D** is left floating to avoid quiescent current on the resistive divider. If we define the total resistor (**R7 + R8**) as **R<sub>P</sub>**, **R7** and **R8** are calculated as:

- $100 \text{ k}\Omega \leq R_P \leq 500 \text{ k}\Omega$
- $R7 = \left( \frac{V_{\text{prim\_min}}}{4} * R_P \right) / 2.2 \text{ V}$
- $R8 = R_P - R7$

Note that **FB\_PRIM\_U** and **FB\_PRIM\_D** must be tied to GND if no primary battery is used.

## 8.4 ZMPPT configuration

Instead of working at a ratio of the open-circuit voltage, the AEM30940 can regulate the input impedance of the BOOST converter so that it matches a constant impedance connected to the **ZMPP** pin (**RZMPP**). In this case, the AEM30940 regulates **V<sub>src</sub>** at a voltage equals to the product of the ZMPP impedance and the current available at the **SRC** input.

- $10 \Omega \leq RZMPP \leq 1 \text{ M}\Omega$

## 8.5 No-battery configuration

If the harvested energy source is permanently available and covers the application purposes or if the application does not need to store energy when the harvested energy source is not available, the storage element may be replaced by an external capacitor **CBATT** of minimum 150  $\mu\text{F}$ .

## 8.6 Storage element information

The energy storage element of the AEM30940 can be a rechargeable battery, a supercapacitor or a large capacitor (minimum 150  $\mu\text{F}$ ). It should be chosen so that its voltage does not fall below **V<sub>ovdis</sub>** even during occasional peaks of the load current. If the internal resistance of the storage element cannot sustain this voltage limit, it is advisable to buffer the battery with a capacitor.

The **BATT** pin that connects the storage element must never be left floating. If the application expects a disconnection of the battery (e.g. because of a user removable connector), the PCB should include a capacitor of at least 150  $\mu\text{F}$ . The leakage current of the storage element should be small as leakage currents directly impact the quiescent current of the subsystem.

### External inductors information

The AEM30940 operates with two standard miniature inductors of 10  $\mu\text{H}$ . **LBOOST** and **LBUCK** must respectively sustain a peak current of at least 250 mA and 50 mA and a switching frequency of at least 10 MHz. Low equivalent series resistance (ESR) favors the power conversion efficiency of the boost and buck converters.

### External capacitors information

The AEM30940 operates with four identical standard miniature ceramic capacitors of 10  $\mu\text{F}$  and one miniature ceramic capacitor of 22  $\mu\text{F}$ . The leakage current of the capacitors should be small as leakage currents directly impact the quiescent current of the subsystem.

#### CSRC

This capacitor acts as an energy buffer at the input of the boost converter. It prevents large voltage fluctuations when the boost converter is switching. The recommended value is 10  $\mu\text{F}$  +/- 20 %.

#### CBUCK

This capacitor acts as an energy buffer for the buck converter. It also reduces the voltage ripple induced by the current pulses inherent to the switched mode of the converter. The recommended value is 10  $\mu\text{F}$  +/- 20 %.

#### CBOOST

This capacitor acts as an energy buffer for the boost converter. It also reduces the voltage ripple induced by the current pulses inherent to the switched mode of the converter. The recommended value is 22  $\mu\text{F}$  +/- 20 %.

#### CHV and CLV

These capacitors ensure a high-efficiency load regulation of the high-voltage and low-voltage LDO regulators. Closed-loop stability requires the value to be in the range of 8  $\mu\text{F}$  to 14  $\mu\text{F}$ .

## 9 Typical Application Circuits

### 9.1 Example circuit 1

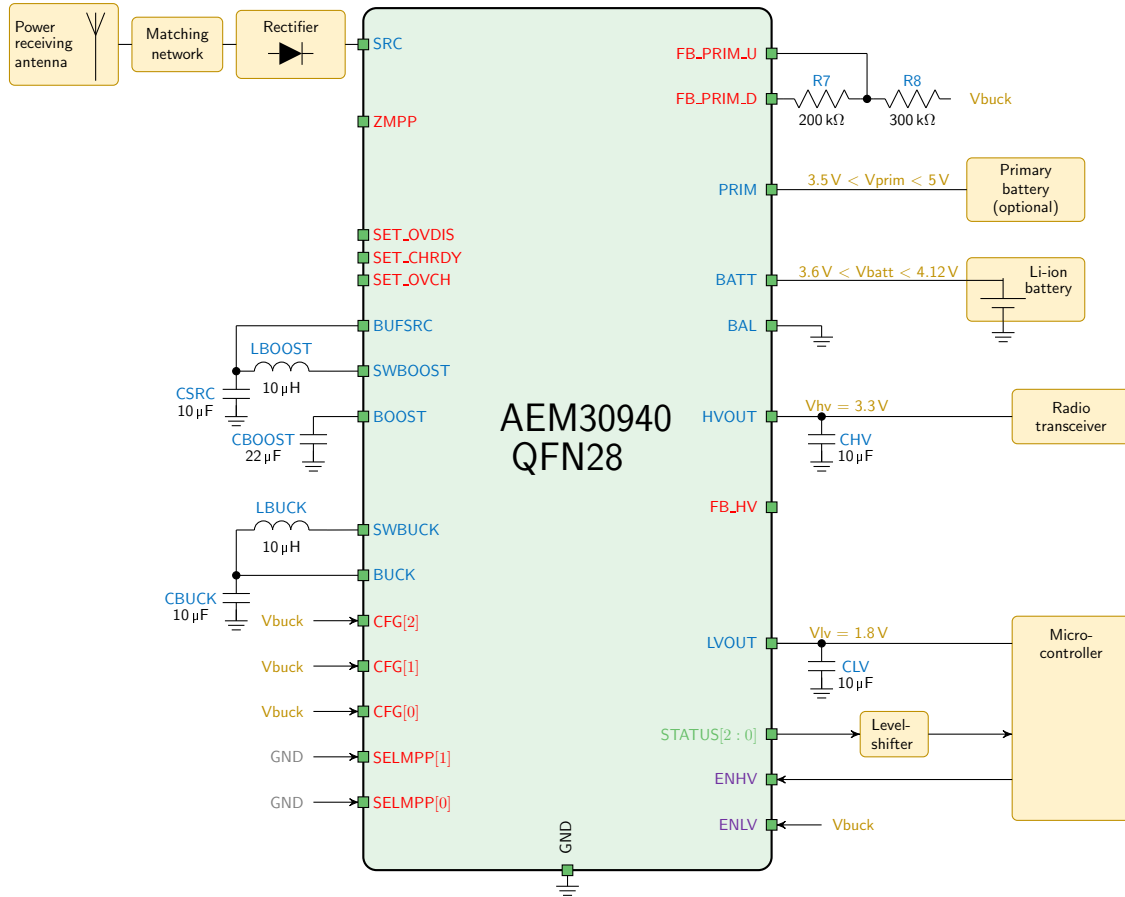

Figure 7: Typical application circuit 1

The energy source is a RF source, and the storage element is a standard Li-ion battery cell. The radio communication makes use of a transceiver that operates from a 3.3 V supply. A micro-controller supplied by a 1.8 V supply controls the application.

This circuit uses a pre-defined operating mode, typical of systems that use standard components for radio and energy storage.

The operating mode pins are connected to:

- $CFG[2:0] = 111$

Referring to Table 8, in this mode, the threshold voltages are:

- $V_{ovch} = 4.12 \text{ V}$
- $V_{chrdy} = 3.67 \text{ V}$
- $V_{ovdis} = 3.60 \text{ V}$

Moreover, the LDOs output voltages are:

- $V_{hv} = 3.3 \text{ V}$
- $V_{lv} = 1.8 \text{ V}$

A primary battery is also connected as a back-up solution. The minimal level allowed on this battery is set at 3.5 V. Following equations on Page 12:

- $R_P = 0.5 \text{ M}\Omega$
- $R_7 = \left(\frac{3.5 \text{ V}}{4} * 0.5 \text{ M}\Omega\right) / 2.2 \text{ V} = 200 \text{ k}\Omega$
- $R_8 = 0.5 \text{ M}\Omega - 200 \text{ k}\Omega = 300 \text{ k}\Omega$

The MPP configuration pins  $SELMPP[1:0]$  are tied to GND (logic low), selecting an MPP ratio of 50 %.

The  $ENLV$  enable pin for the low-voltage LDO is tied to  $BUCK$ . The microcontroller will be enabled when  $V_{batt}$  and  $V_{boost}$  exceed  $V_{chrdy}$  as the low-voltage regulator supplies it.

The application software can enable or disable the radio transceiver with a GPIO connected to  $ENHV$ .

## 9.2 Example circuit 2

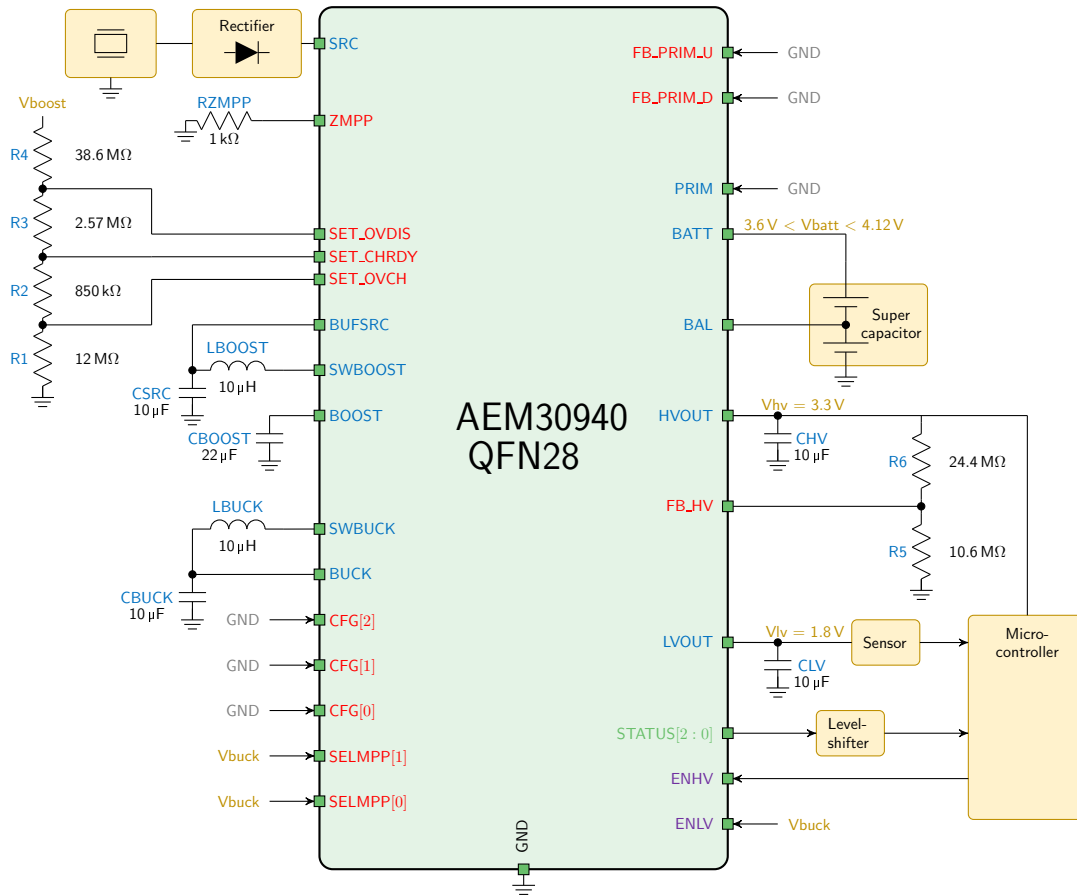

Figure 8: Typical application circuit 2

The energy source is a piezo source, and the storage element is a dual-cell supercapacitor. The supercapacitor can be completely depleted during the cold start.

Moreover, **BAL** is connected to the dual-cell supercapacitor to compensate for any mismatch between the two cells and in that way protect the supercapacitor.

A micro-controller pilots and collects information from a sensor. The operating mode pins are connected to:

- $CFG[2:0] = 000$

The user wants a custom configuration with **Vovch**, **Vchrdy** and **Vovdis** at 4.5 V, 4.2 V and 3.5 V, respectively. The user chooses 54 MΩ for **RT**. Following the equation in page 11:

- $R1 = 54 \text{ M}\Omega \left( \frac{1 \text{ V}}{4.5 \text{ V}} \right) = 12 \text{ M}\Omega$
- $R2 = 54 \text{ M}\Omega \left( \frac{1 \text{ V}}{4.2 \text{ V}} - \frac{1 \text{ V}}{4.5 \text{ V}} \right) = 850 \text{ k}\Omega$
- $R3 = 54 \text{ M}\Omega \left( \frac{1 \text{ V}}{3.5 \text{ V}} - \frac{1 \text{ V}}{4.2 \text{ V}} \right) = 2.57 \text{ M}\Omega$

- $R4 = 54 \text{ M}\Omega \left( 1 - \frac{1 \text{ V}}{3.5 \text{ V}} \right) = 38.6 \text{ M}\Omega$

In the custom mode, the **Vlv** equals 1.8 V and the application software can enable or disable the sensor with a GPIO connected to **ENLV**.

On **Vhv**, the user wants a 3.3 V voltage. As shown in page 11, the user chooses a resistor **RV** equal to 35 MΩ

- $R5 = 35 \text{ M}\Omega \left( \frac{1 \text{ V}}{3.3 \text{ V}} \right) = 10.6 \text{ M}\Omega$
- $R6 = 35 \text{ M}\Omega \left( 1 - \frac{1 \text{ V}}{3.3 \text{ V}} \right) = 24.4 \text{ M}\Omega$

The **ENHV** enable pin for the high-voltage LDO is tied to **BUCK**. The microcontroller is enabled when **Vbatt** and **Vboost** exceeds **Vchrdy** as the high-voltage regulator supplies it.

The MPP configuration pins **SELMPP[1:0]** are tied to **BUCK** (logic high), selecting the ZMPPT configuration to match a 1 KΩ impedance.

No primary battery is connected and the **PRIM**, **FB\_PRIM\_U** and **FB\_PRIM\_D** pins are tied to **GND**.

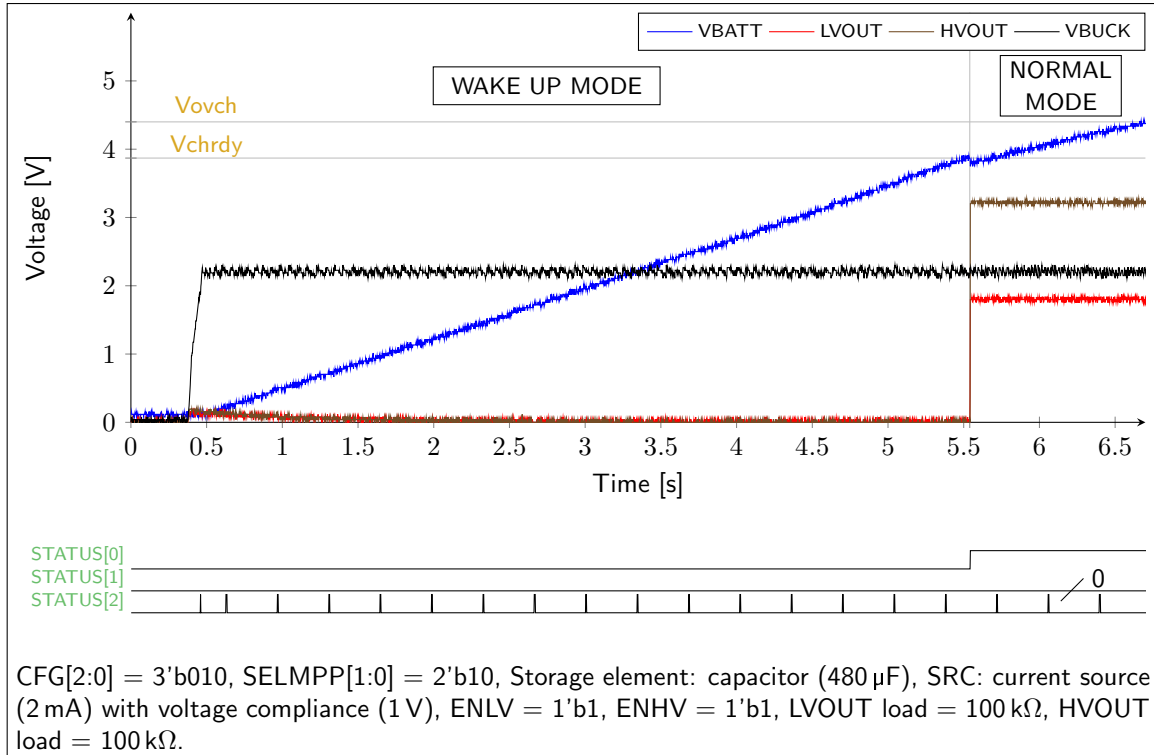

Figure 9: Cold start with a capacitor connected to BATT

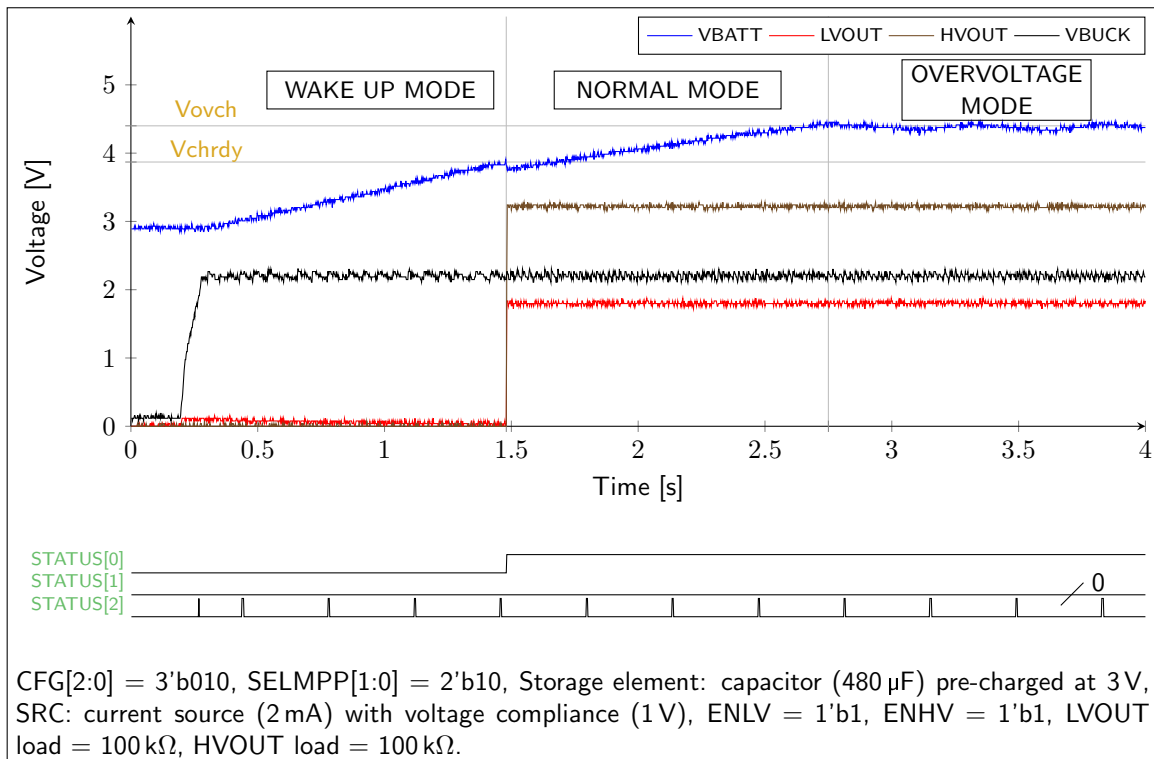

Figure 10: Cold start with a battery connected to BATT

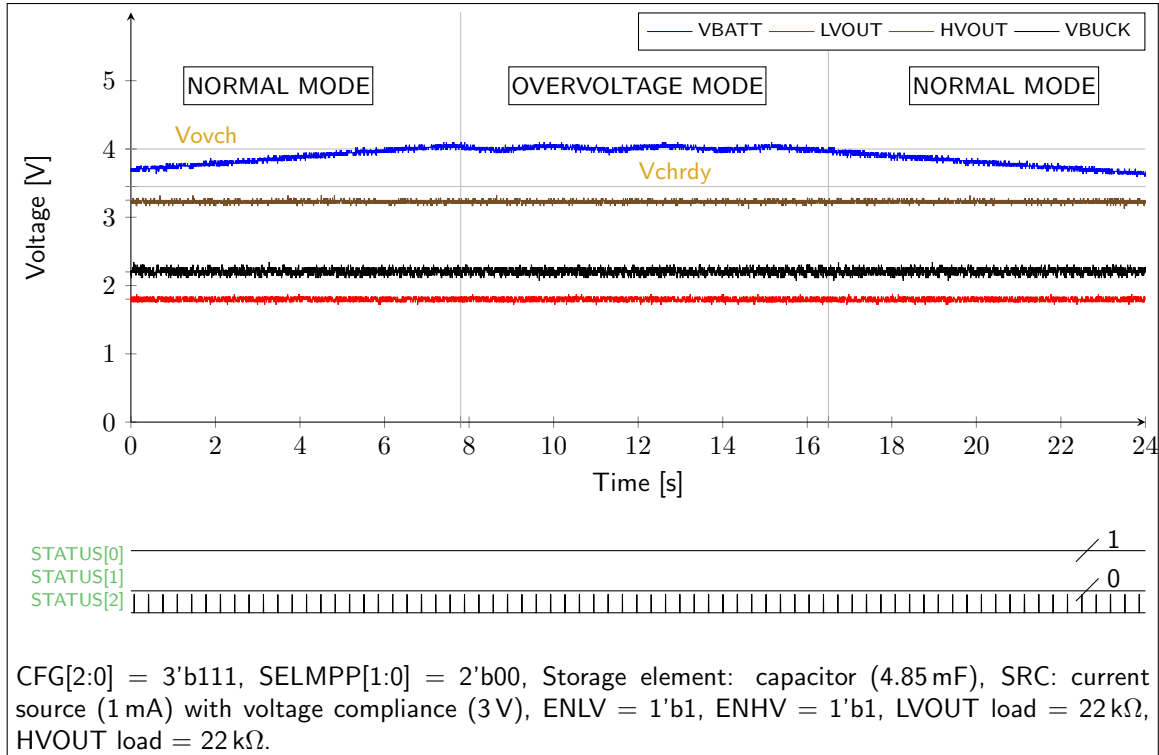

Figure 11: Overvoltage mode

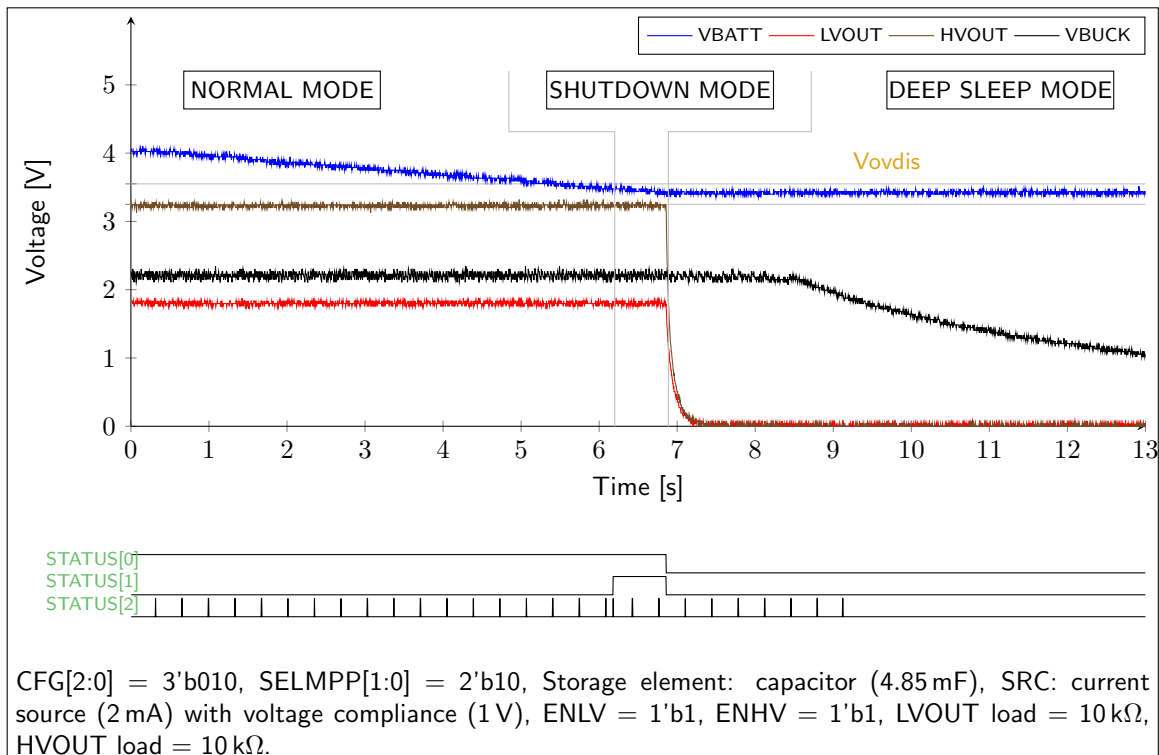

Figure 12: Shutdown mode (without primary battery)



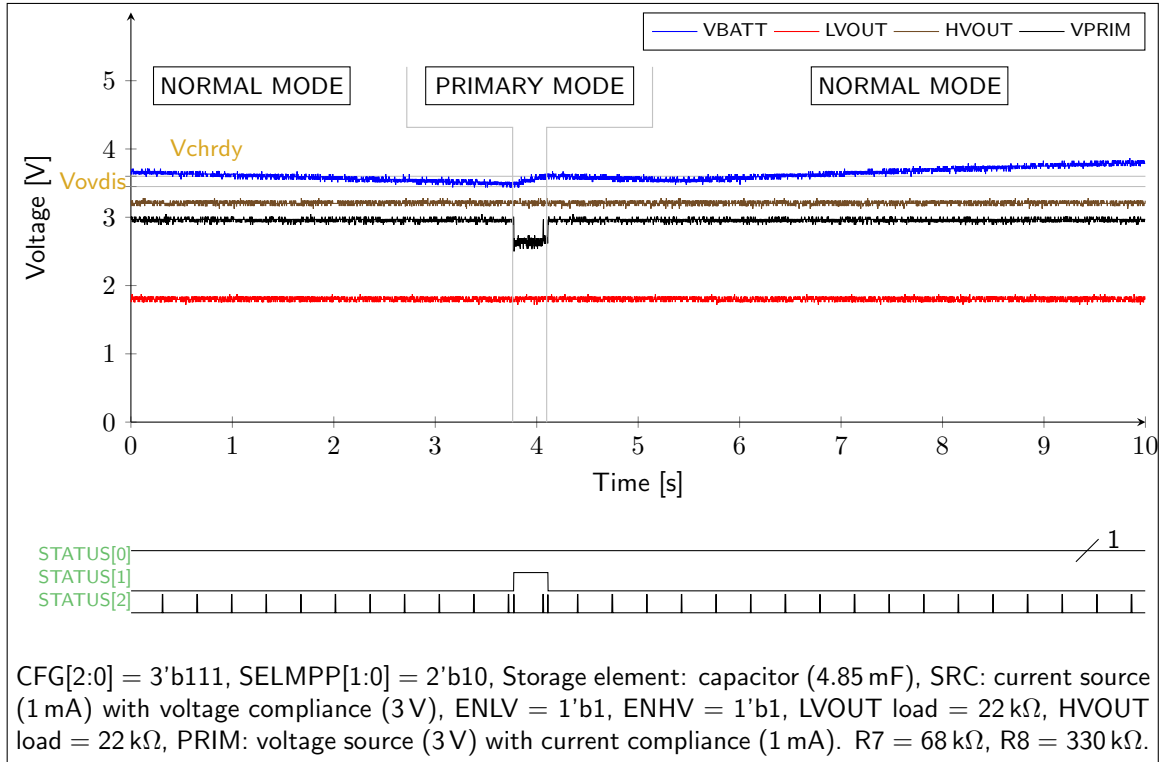

Figure 13: Switch to primary battery if the battery is overdischarged

## 10 Performance Data

### 10.1 BOOST conversion efficiency

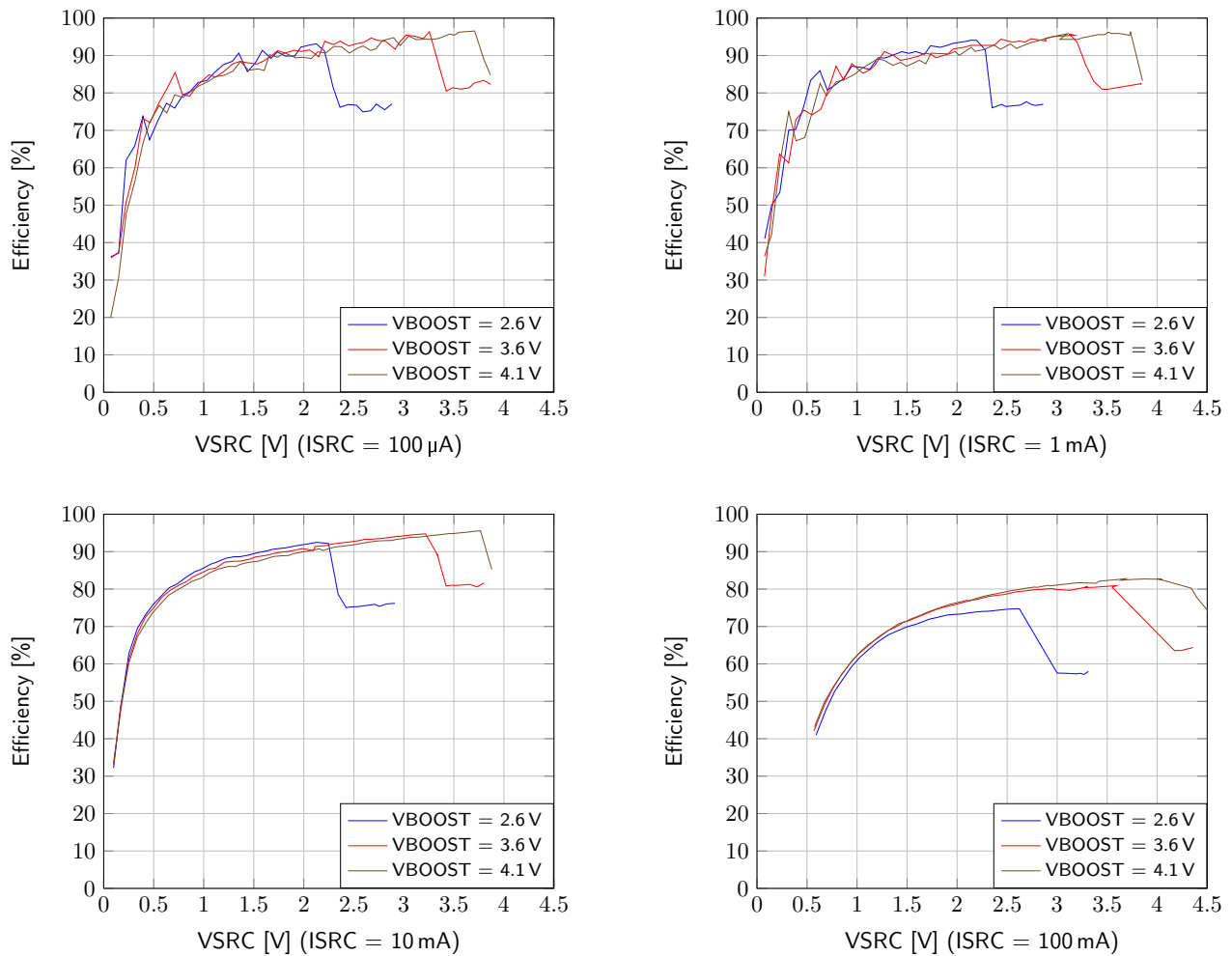

Figure 14: Boost efficiency for Isrc at 100 µA, 1 mA, 10 mA and 100 mA

### 10.2 Quiescent current

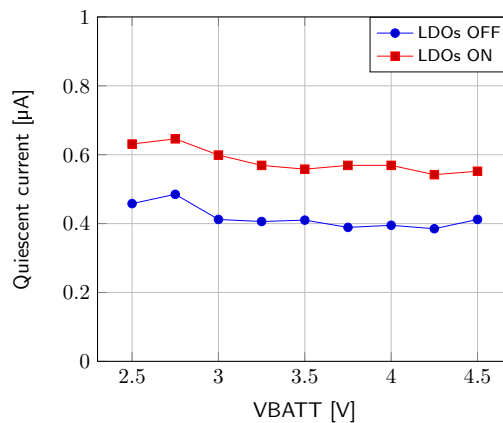

Figure 15: Quiescent current with LDOs on and off

### 10.3 High-voltage LDO regulation

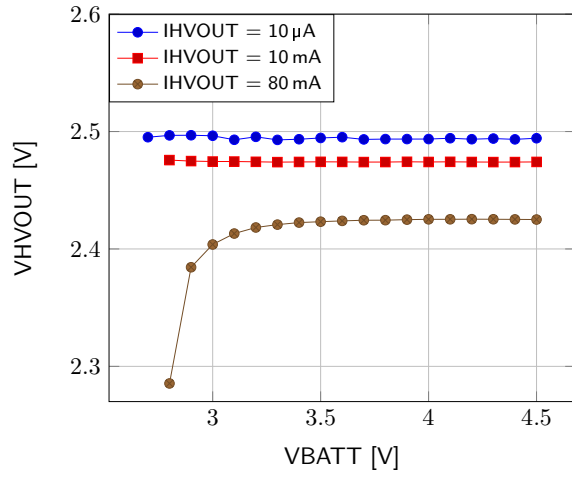
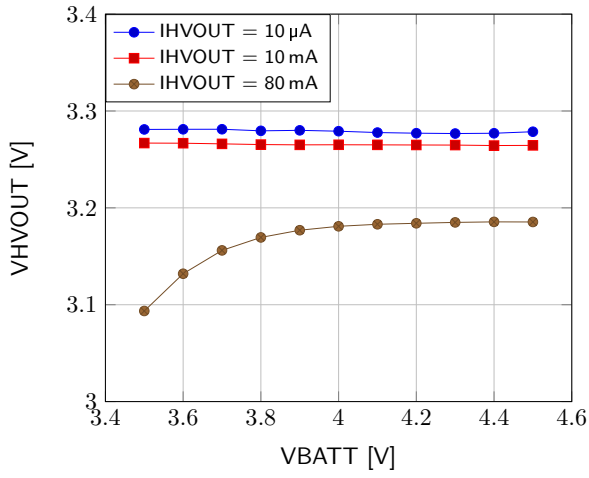

Figure 16: HVOUT at 3.3 V and 2.5 V

### 10.4 Low-voltage LDO regulation

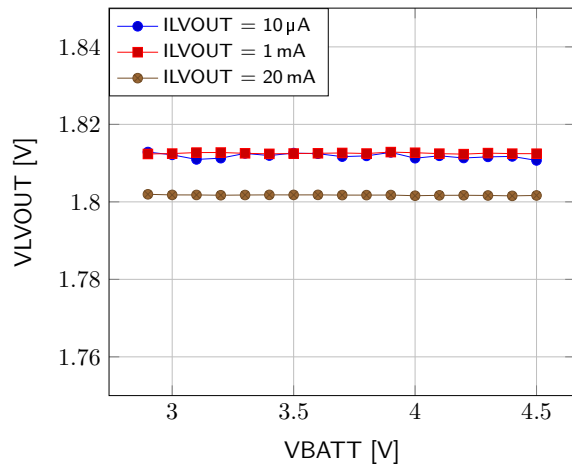
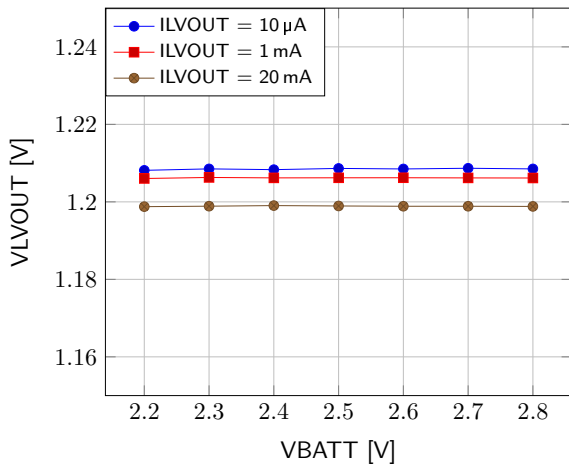

Figure 17: LVOUT at 1.2 V and 1.8 V

## 10.5 High-voltage LDO efficiency

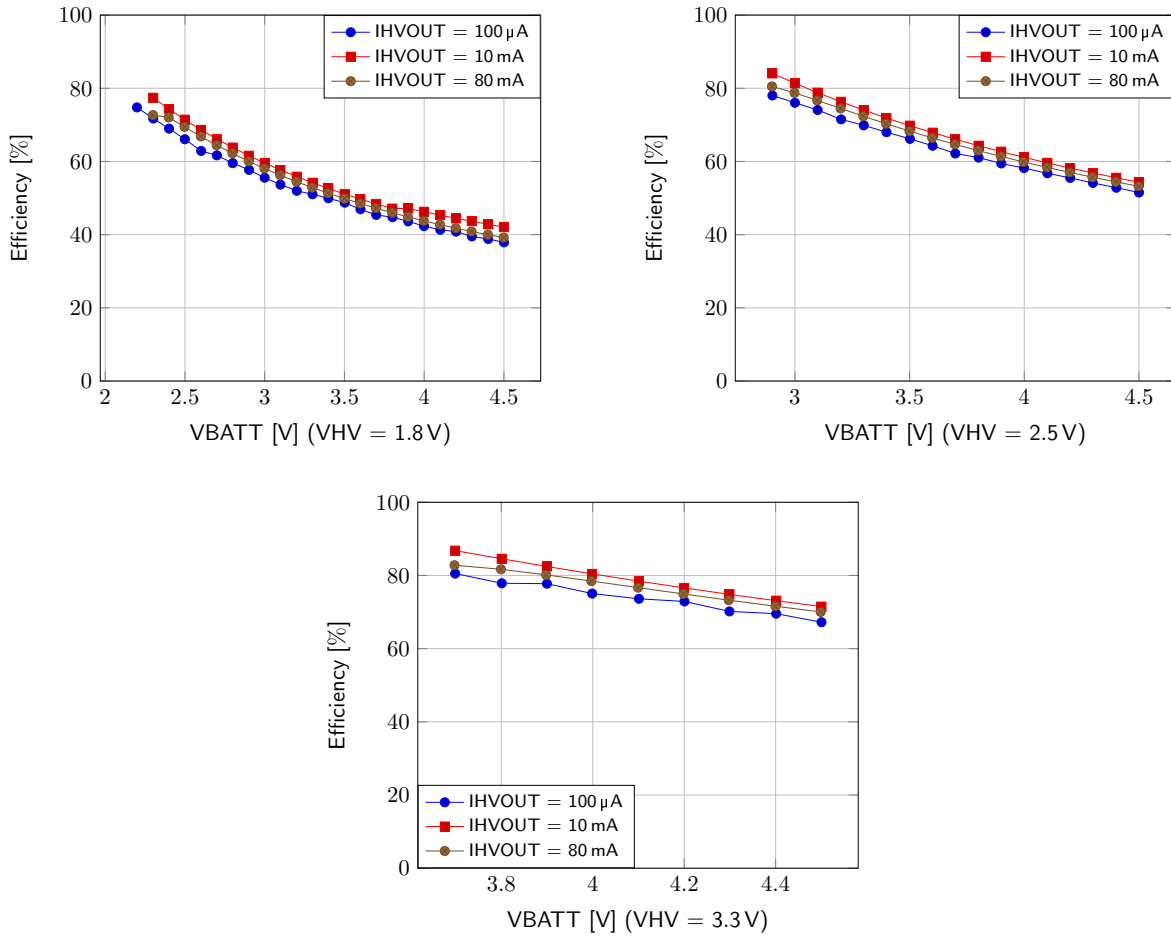

Figure 18: HVOUT efficiency at 1.8 V, 2.5 V and 3.3 V

The theoretical efficiency of a LDO can be simply calculated as  $\frac{V_{out}}{V_{in}}$  if quiescent current can be neglected with regards to the output current. In the case of the high-voltage LDO, the theoretical efficiency is equal to  $\frac{V_{hv}}{V_{batt}}$ .

## 10.6 Low-voltage LDO efficiency

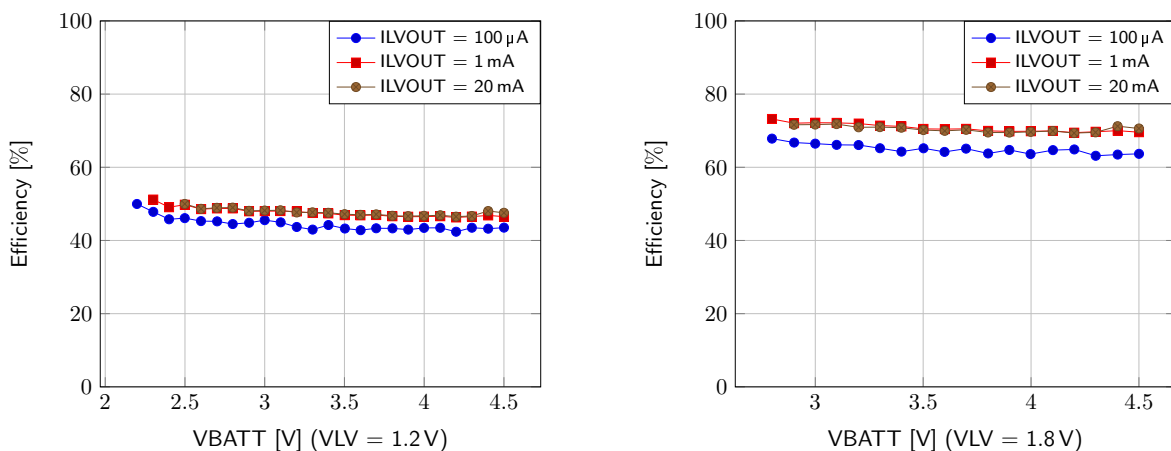

Figure 19: Efficiency of BUCK cascaded with LVOUT at 1.2 V and 1.8 V

The theoretical efficiency of the low-voltage LDO is equal to  $\frac{V_{lv}}{V_{buck}}$ . Starting from the battery, the efficiency of the buck converter has to be taken into account (see Figure 4). The efficiency between  $V_{batt}$  and  $V_{lv}$  is therefore equal to  $\eta_{buck} \frac{V_{lv}}{V_{buck}}$ .

## 10.7 RF path efficiency

To be able to harvest efficiently from an RF source with the AEM30940, a matching network and a RF rectifier are necessary. As a reference design, e-peas proposes a low-power and high-power version of the required matching network and rectifier. The low-power reference design offers better efficiency at input power lower than -5 dBm. The high-power reference design offers better efficiency for input power above -5 dBm. Actual designs are proposed for 2 frequency bands: 863-868 MHz and 915-921MHz.

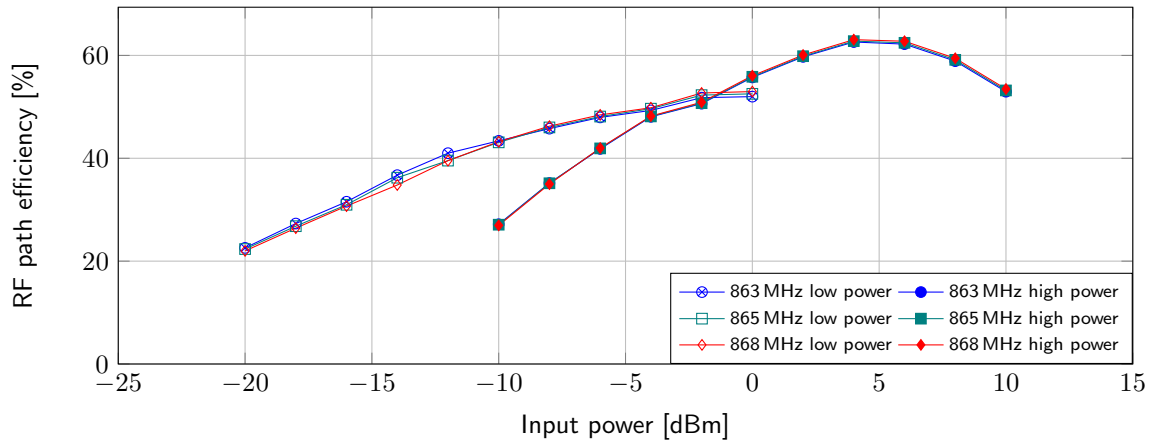

Figure 20: Efficiency for 863-868 MHz band

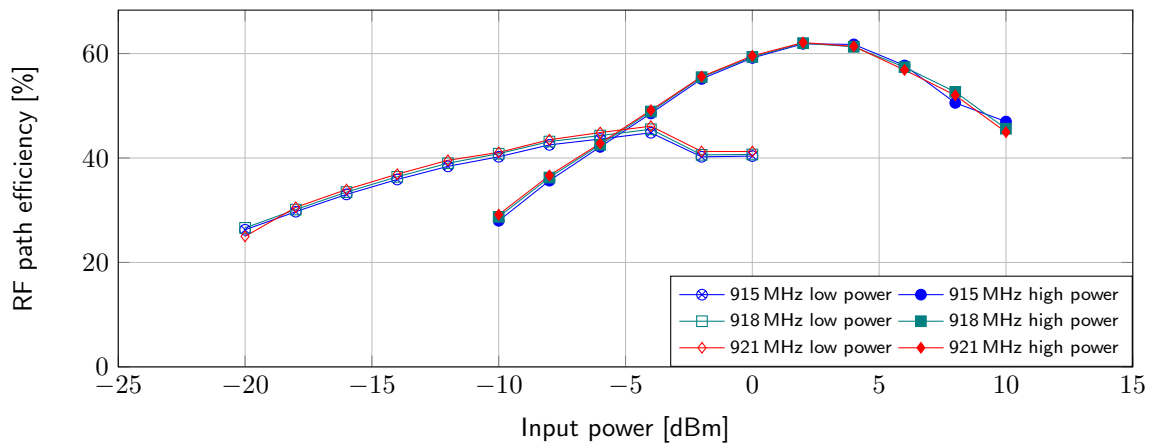

Figure 21: Efficiency for 915-921 MHz band

The RF path efficiency is defined as the ratio between the power available at the output of the rectifier (SRC) and the power at the input of the matching network ( $50\Omega$  single input SMA).

### 10.8 Overall efficiency

As a reminder, the low-power reference design is optimized for input power lower than -5 dBm at the receiver antenna. The high-power reference design is optimized for input power above -5 dBm at the receiver antenna. The overall efficiency is defined as the ratio between the power available at the output of the internal boost converter and the power at the input of the matching network (50 Ω single input SMA).

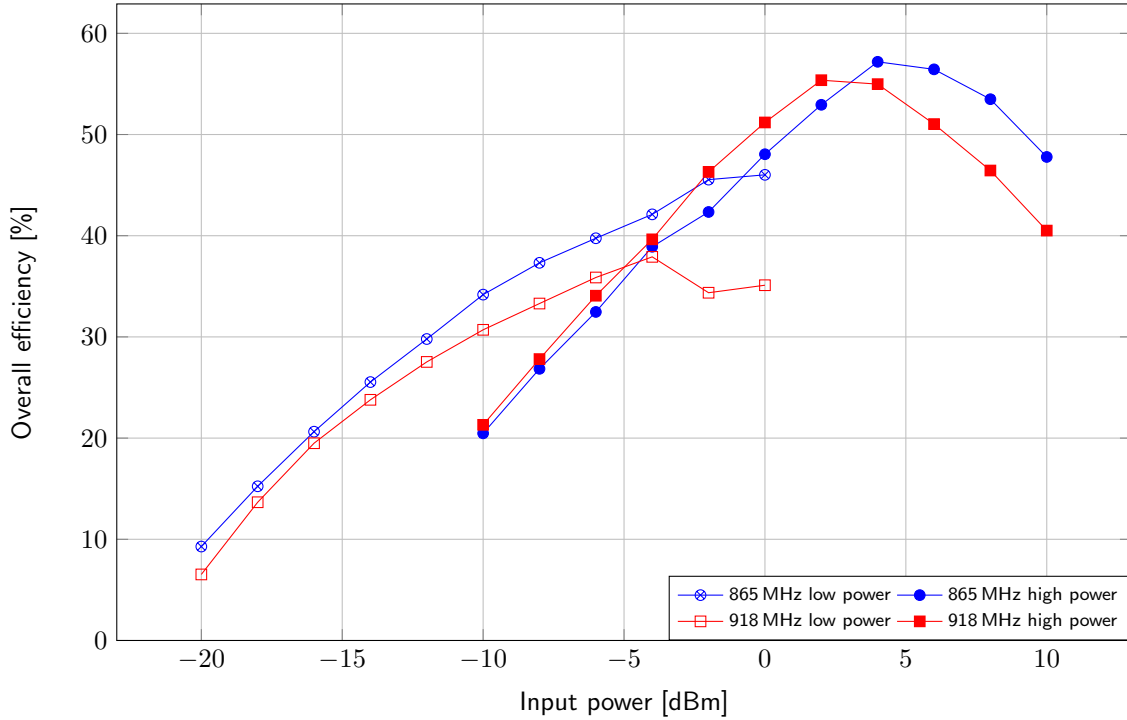

Figure 22: Overall efficiency (RF path and boost converter) with VBOOST = 3.5 V

**11 Schematic**

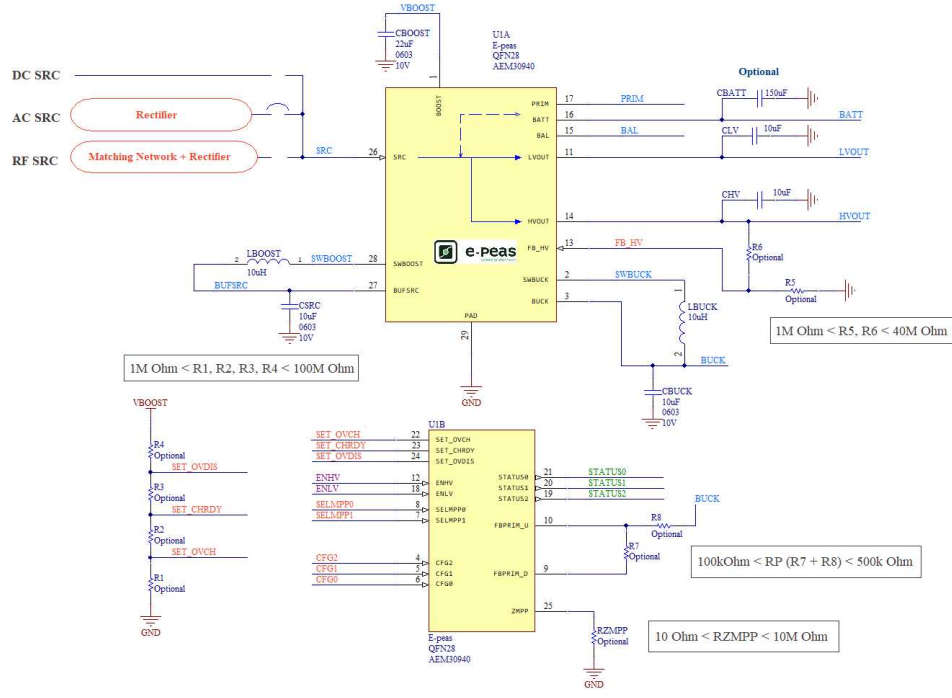

Figure 23: Schematic example

Designator	Description	Quantity	Manufacturer	Part Number
CBOOST	Ceramic Cap 22 µF, 10 V, 20 %, X5R 0603	1	Murata	GRM188R61A226ME15D
CBUCK	Ceramic Cap 10 µF, 10 V, 20 %, X5R	1	TDK	C1608X5R1A106M080AC
CHV	Ceramic Cap 10 µF, 10 V, 20 %, X5R	1	TDK	C1608X5R1A106M080AC
CLV	Ceramic Cap 10 µF, 10 V, 20 %, X5R	1	TDK	C1608X5R1A106M080AC
CSRC	Ceramic Cap 10 µF, 10 V, 20 %, X5R	1	TDK	C1608X5R1A106M080AC
LBOOST	Power Inductor 10 µH - 0,54 A - LPD5030V	1	Coilcraft	LPD5030V-103MR
	Power Inductor 10 µH - 0,55 A - LPS4012	1	Würth	744 040 321 00
LBUCK	Power Inductor 10 µH - 0,25 A	1	TDK	MLZ1608M100WT
U1	AEM30940 - Symbol QFN28	1		order at <a href="mailto:sales@e-peas.com">sales@e-peas.com</a> or <a href="#">Where to buy</a>

Table 10: BOM example for AEM30940 and its required passive components

## 12 Layout

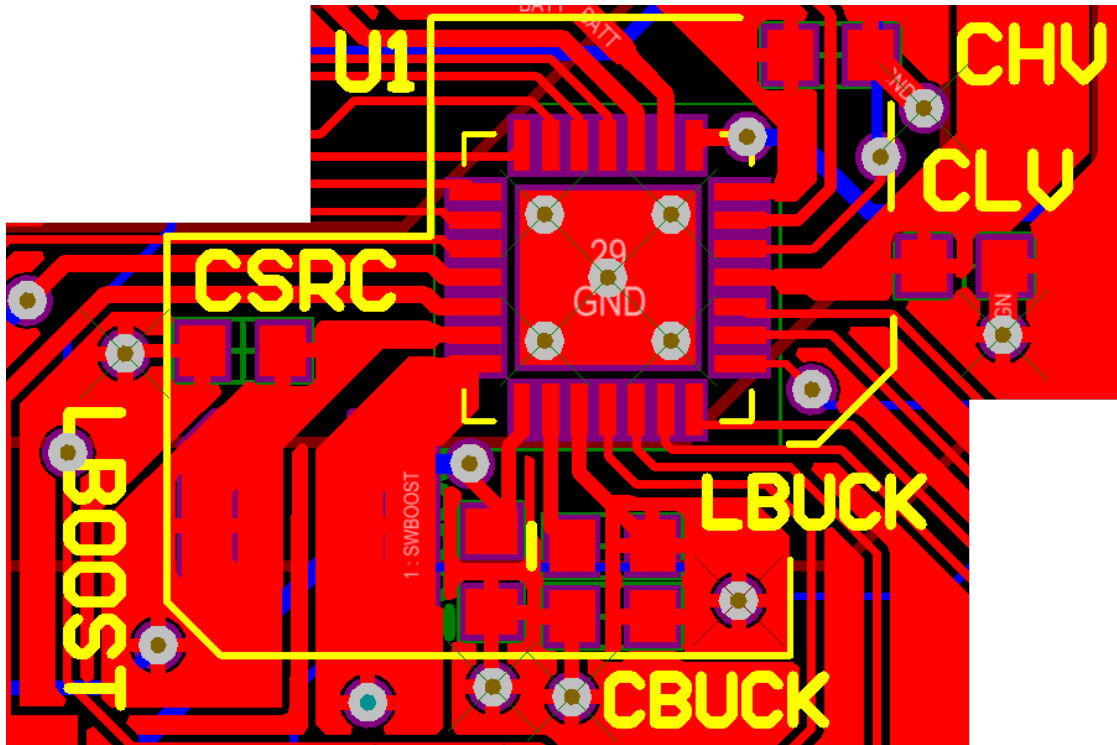

Figure 24: Layout example for the AEM30940 and its passive components

Note: Schematic, symbol and footprint for the e-peas component can be ordered by contacting the e-peas support: [support@e-peas.com](mailto:support@e-peas.com)



## 13 Package Information

### 13.1 Plastic quad flatpack no-lead (QFN28 5x5mm)

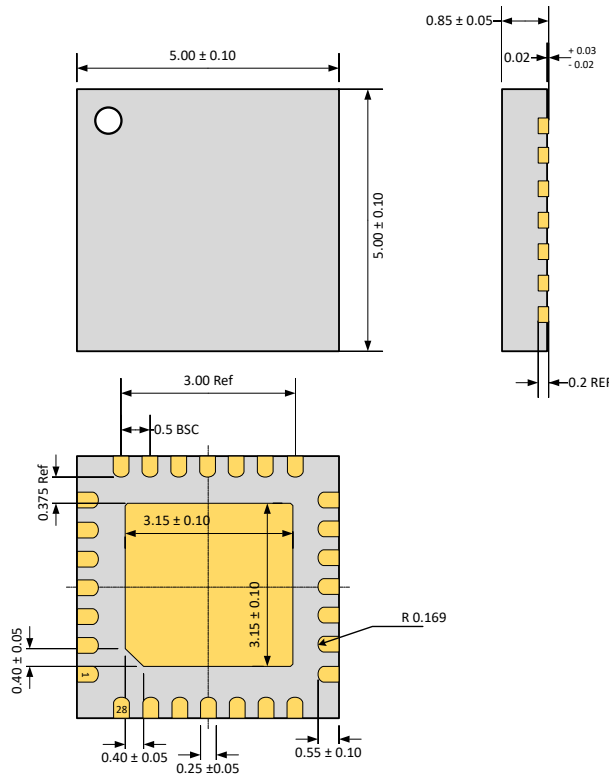

Figure 25: QFN28 5x5mm

### 13.2 Board layout

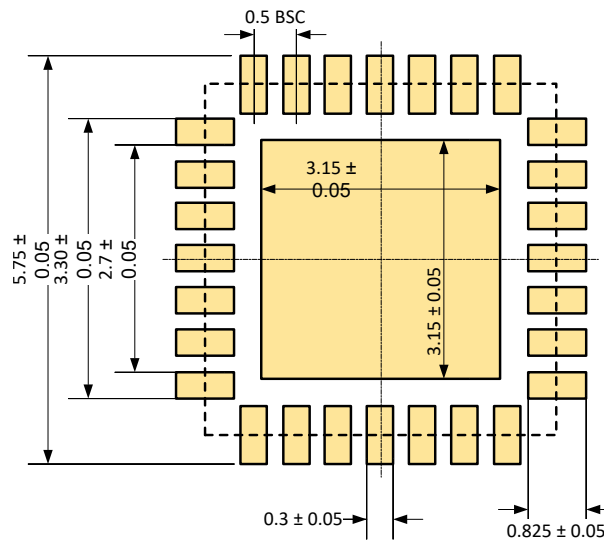

Figure 26: Board layout

## Revision history

Revision	Date	Description
1.0	July, 2018	Creation of the document.
1.2	June, 2019	<ul style="list-style-type: none"><li>- p21, 22 → Updated efficiencies measurements;</li><li>- p5 → ESD specifications;</li><li>- p3 → HVOUT voltage on Figure 1 <del>4.2V</del> → 4.1V;</li><li>- p1, 3, 7, 8 → AC source instead of Power receiving antenna for front page Figure , Figure 1, Figure 3 and Figure 4.</li></ul>

## X-ON Electronics

Largest Supplier of Electrical and Electronic Components

*Click to view similar products for [Power Management IC Development Tools](#) category:*

*Click to view products by [e-peas](#) manufacturer:*

Other Similar products are found below :

[EVB-EP5348UI](#) [MIC23451-AAAYFL EV](#) [MIC5281YMME EV](#) [124352-HMC860LP3E](#) [DA9063-EVAL](#) [ADP122-3.3-EVALZ](#) [ADP130-0.8-EVALZ](#) [ADP130-1.8-EVALZ](#) [ADP1740-1.5-EVALZ](#) [ADP1870-0.3-EVALZ](#) [ADP1874-0.3-EVALZ](#) [ADP199CB-EVALZ](#) [ADP2102-1.25-EVALZ](#) [ADP2102-1.875EVALZ](#) [ADP2102-1.8-EVALZ](#) [ADP2102-2-EVALZ](#) [ADP2102-3-EVALZ](#) [ADP2102-4-EVALZ](#) [AS3606-DB](#) [BQ25010EVM](#) [BQ3055EVM](#) [ISLUSBI2CKIT1Z](#) [LM2734YEVAL](#) [LP38512TS-1.8EV](#) [EVAL-ADM1186-1MBZ](#) [EVAL-ADM1186-2MBZ](#) [ADP122UJZ-REDYKIT](#) [ADP166Z-REDYKIT](#) [ADP170-1.8-EVALZ](#) [ADP171-EVALZ](#) [ADP1853-EVALZ](#) [ADP1873-0.3-EVALZ](#) [ADP198CP-EVALZ](#) [ADP2102-1.0-EVALZ](#) [ADP2102-1-EVALZ](#) [ADP2107-1.8-EVALZ](#) [ADP5020CP-EVALZ](#) [CC-ACC-DBMX-51](#) [ATPL230A-EK](#) [MIC23250-S4YMT EV](#) [MIC26603YJL EV](#) [MIC33050-SYHL EV](#) [TPS60100EVM-131](#) [TPS65010EVM-230](#) [TPS71933-28EVM-213](#) [TPS72728YFFEVM-407](#) [TPS79318YEQEV](#) [ISL85033EVAL2Z](#) [UCC28810EVM-002](#) [XILINXPWR-083](#)