

S1D13A04 LCD/USB Companion Chip

February 2009

The S1D13A04 is an LCD/USB solution designed for seamless connection to a wide variety of microprocessors. The S1D13A04 integrates a USB slave controller and an LCD graphics controller with an embedded 160K byte SRAM display buffer. The LCD controller, based on the popular S1D13706, supports all standard panel types including the Sharp HR-TFT family of products. In addition to the S1D13706 feature set, the S1D13A04 includes a Hardware Acceleration Engine to greatly improve screen drawing functions. The USB controller provides revision 1.1 compliance for applications requiring a USB client. This high level of integration provides a low cost, low power, single chip solution to meet the demands of embedded markets requiring USB client support, such as Mobile Communications devices and Palm-size PCs.

The S1D13A04 utilizes a guaranteed low-latency CPU architecture that provides support for microprocessors without READY/WAIT# handshaking signals. The 32-bit internal data path, write buffer and the Hardware Acceleration Engine provide high performance bandwidth into display memory allowing for fast display updates. 'Direct' support for the Sharp HR-TFT removes the requirement of an external Timing Control IC.

Additionally, products requiring a rotated display can take advantage of the SwivelView™ feature which provides hardware rotation of the display memory transparent to the software application. The S1D13A04 also provides support for "Picture-in-Picture Plus" (a variable size Overlay window).

The S1D13A04, with its integrated USB client, provides impressive support for Palm OS® handhelds. However, its impartiality to CPU type or operating system makes it an ideal display solution for a wide variety of applications.

■ FEATURES

- Embedded 160KB Display Buffer.
- Low Operating Voltage.
- Low-latency CPU interface.
- Direct support for multiple CPU types.
- Programmable resolutions and color depths.
- Passive LCD support.
- Active Matrix LCD support.
- 'Direct' Sharp HR-TFT support.
- USB Client, Revision 1.1 compliant.
- SwivelView™ (90°, 180°, 270° hardware rotation of displayed image).
- "Picture-in-Picture Plus".
- Pixel Doubling.
- Hardware Acceleration Engine.
- Software Initiated Power Save Mode.
- Software Video Invert.
- 121-pin PFBGA or TQFP15 128-pin package.

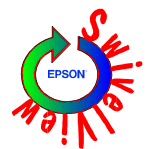

■ SYSTEM BLOCK DIAGRAM

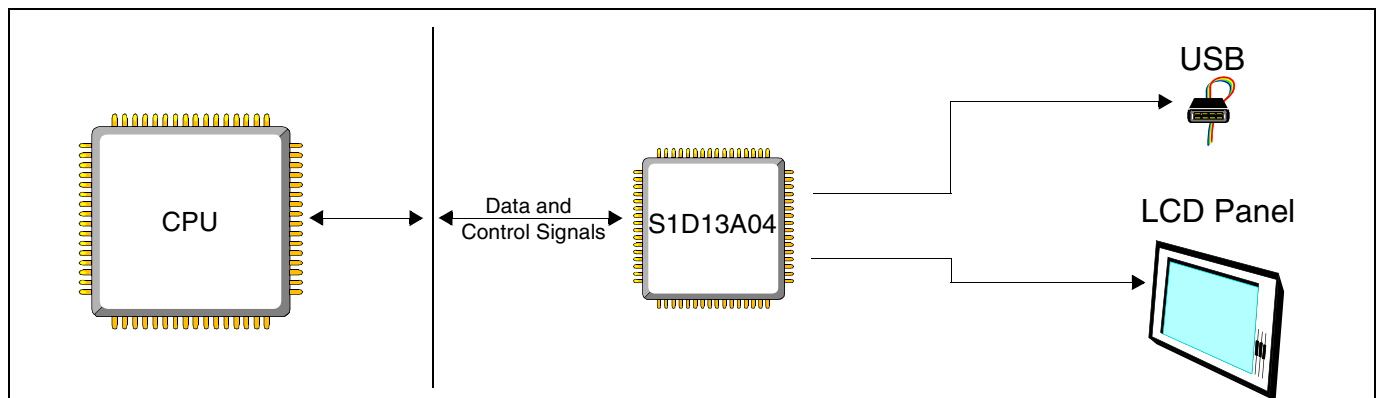

S1D13A04

DESCRIPTION

CPU Interface

- 'Fixed' low-latency CPU access times.
- Direct support for:
 - Hitachi SH-4 / SH-3.
 - Motorola M68xxx (REDCAP2, DragonBall, ColdFire).
 - MPU bus interface with programmable READY.

Memory Interface

- Embedded 160K byte SRAM display buffer.

Power Down Modes

- Software Initiated Power Save Mode.

Operating Voltage

- $CORE_{VDD}$ $2.0 \pm 10\%$ or $2.5 \pm 10\%$ volts.
- IO_{VDD} $3.0 \pm 10\%$ volts.

Clock Source

- Three independent clock inputs including dedicated USB clock (single clock possible if USB not required).
- Flexible clock source selection and divides.

Package

- 121-pin PFBGA.
- 128-pin TQFP15.

Integrated USB Features

- USB Client, Revision 1.1 Compliant.

Integrated LCD Controller Features

- 1/2/4/8/16 bit-per-pixel (bpp) support.
- Up to 64 gray shades on monochrome passive panels.
- Up to 64K colors on passive/active matrix panels.
- Single-panel, single-drive passive displays.
 - 4/8-bit monochrome LCD interface.
 - 4/8/16-bit color passive LCD interface.
- 9/12/18-bit Active matrix TFT interface.
- 18-bit 'Direct' HR-TFT interface.
- SwivelView: hardware rotation by 90°, 180°, 270°.
- "Picture-in-Picture Plus": displays a variable size window overlaid over background image.
- Pixel Doubling: horizontal and vertical resolutions can be doubled without any additional memory.
- Software video invert.
- Typical resolutions supported:
 - 320x240@16 bpp
 - 320x320@8 bpp
 - 160x160@16 bpp (2 pages)
 - 160x240@16 bpp
- 2D BitBLT Engine.

Write BLT	Transparent Write BLT
Move BLT	Transparent Move BLT
Solid Fill BLT	Read BLT
Pattern Fill	Color Expansion BLT
Move BLT with Color Expansion	

CONTACT YOUR SALES REPRESENTATIVE FOR THESE COMPREHENSIVE DESIGN TOOLS

- S1D13A04 Technical Manual
- S5U13A04 Evaluation Boards
- CPU Independent Software Utilities
- Palm OS® Hardware Abstraction Layer
- Windows® CE Display Driver
- VXWorks® Tornado™ Display Driver

Japan

Seiko Epson Corporation
 IC International Sales Group
 421-8, Hino, Hino-shi
 Tokyo 191-8501, Japan
 Tel: +81-42-587-5814
 Fax: +81-42-587-5117

North America

Epson Electronics America, Inc.
 2580 Orchard Parkway
 San Jose, CA 95131, USA
 Tel: +1-800-228-3964
 Fax: +1-408-922-0238

China

Epson (China) Co., Ltd.
 7F, Jinbao Bldg.
 No. 89 Jinbao St.
 Dongcheng District
 Beijing 100005, China
 Tel: +86-10-6410-6555
 Fax: +86-10-6410-7320

Taiwan

Epson Taiwan Technology & Trading Ltd.
 14F, No. 7
 Song Ren Road
 Taipei 110, Taiwan
 Tel: +886-2-8786-6688
 Fax: +886-2-8786-6660

Hong Kong

Epson Hong Kong Ltd.
 20/F, Harbour Centre
 25 Harbour Road
 Wanchai, Hong Kong
 Tel: +852-2585-4600
 Fax: +852-2827-4346

Europe

Epson Europe Electronics GmbH
 Riesstrasse 15
 80992 Munich, Germany
 Tel: +49-89-14005-0
 Fax: +49-89-14005-110

Singapore

Epson Singapore Pte., Ltd.
 1 HarbourFront Place
 #03-02 HarbourFront Tower One
 Singapore 098633
 Tel: +65-6586-5500
 Fax: +65-6271-3182

Korea

Seiko Epson Corp.
 Korea Office
 50F, LK1 63 Bldg.
 60 Yoido-dong, Youngdeungpo-Ku,
 Seoul, 150-763, Korea
 Tel: +82-2-784-6027
 Fax: +82-2-767-3677

© SEIKO EPSON CORPORATION 2000-2009. All rights reserved. Information in this document is subject to change without notice. You may download and use this document, but only for your own use in evaluating Seiko Epson/EPSON products. You may not modify the document. Epson Research and Development, Inc. disclaims any representation that the contents of this document are accurate or current. The Programs/Technologies described in this document may contain material protected under U.S. and/or International Patent laws. EPSON is a registered trademark of Seiko Epson Corporation. Palm Computing is a registered trademark and the Palm OS platform Platinum logo is a trademark of Palm Computing, Inc., 3Com or its subsidiaries. Microsoft, Windows, and the Windows CE Logo are registered trademarks of Microsoft Corporation. All other trademarks are the property of their respective owners.

X-ON Electronics

Largest Supplier of Electrical and Electronic Components

Click to view similar products for [Display Drivers & Controllers](#) category:

Click to view products by [Epson](#) manufacturer:

Other Similar products are found below :

[ICB2FL01G](#) [HV5812PJ-G-M904](#) [TW8813-LB2-GR](#) [TW8811-PC2-GR](#) [MAX1839EEP+](#) [TW9907-TA1-GR](#) [LX27901IDW](#) [SSD2828QN4](#)
[ICB2FL01GXUMA2](#) [DLP2000FQC](#) [PAD1000YFFR](#) [S1D13746F01A600](#) [FIN324CMLX](#) [AD8387JSVZ](#) [DLPC6421ZPC](#) [HV852K7-G](#)
[HV859K7-G](#) [HV857K7-G](#) [DIO2133CT14](#) [S1D13506F00A200](#) [S1D13L03F00A100-40](#) [TW2836-BA1-GR](#) [SSD2829QL9](#) [MAX749CSA+T](#)
[MAX4820EUP+T](#) [ICL7135CAI+](#) [ICL7135CMH+D](#) [ICL7137CMH+D](#) [MAX25221BATJ/V+](#) [S1D13748B00B100](#) [S1D13A05B00B200](#)
[MAX3738ETG+T](#) [MAX8722CEEG+](#) [MAX749CPA+](#) [MAX8785AETI+](#) [ICL7135CQI+](#) [HV518PJ-G-M903](#) [HV5812P-G](#) [HV5812PJ-G](#)
[HV5812WG-G](#) [HV7224PG-G](#) [HV853K7-G](#) [HV860K7-G](#) [HV6810WG-G](#) [HV823LG-G](#) [HV857MG-G](#) [HV833MG-G](#) [HV857LMG-G](#)
[HV850MG-G](#) [HV859MG-G](#)