

## Voice Guidance LSI

### ■ Overview

The S1V3S344 is an LSI incorporating built-in flash memory for voice data and featuring pin compatibility with existing S1V3034x Series devices\*. It features high-compression, high-quality audio decoding functions, built-in voice data flash memory, and a DA converter, making it ideal for use in voice guidance products. The voice data creation tool for EPSON voice guidance LSI allows easy creation of high-quality voice data without the need for studio recording. All functions are controlled by commands via a serial interface for easy addition to any existing system incorporating a host.

The S1V3S344 will help evaluate voice output and help users reduce time-to-market for products incorporating built-in voice guidance functions.

\* External parts differ from S1V3034x Series devices.

### ■ Features

- **Audio playback**
  - High-compression, high-quality audio decoder (proprietary Epson data format)
  - Bitrate: 40 kbps, 32 kbps, 24 kbps, 16 kbps
  - Sampling rate: 16 kHz
- **Sequencer function (phrase interval setting)**
  - Sequence setting for up to 64 phrases (unlimited combinations)
  - Variable phrase interval delay setting: 0 ms or 20 ms to 2,047 ms (in 1 ms steps)
- **Voice data built-in flash memory<sup>\*1</sup>**
  - Incorporates the following memory for voice data
    - 512 kbytes (approx. 4 minutes/16 kbps)
    - Erase/write cycles: 10,000 cycles (typ.)  
1,000 cycles (min)
    - Data retention: 10 years (min)
- **Host interface**
  - Clock synchronized serial interface, supporting UART and I2C
  - Command control
- **High-quality 16-bit DA converter**
  - Sampling rate ( $f_s$ ): 16 kHz
  - Input bits: 16 bits
- **Clock**
  - Clock input: 32.768 kHz or 12.288 MHz
  - Crystal oscillator: 32.768 kHz
- **Package**
  - QFP-52pin (10 mm × 10 mm) 0.65 mm pin pitch
- **Power supply voltage**
  - 5.0 V ±0.5 V (single power supply)
  - 3.3 V ±0.3 V (single power supply)

### ■ Standard application system

The S1V3S344 standard application system is configured as shown in the diagram below. The S1V3S344 is command-controlled by the host using a messaging protocol via the serial interface.

Controlled by commands sent from the host via the serial interface after power-on resetting, the S1V3S344 outputs voice audio while internally decoding and processing internal or streamed (via host command transfer) compressed audio data.

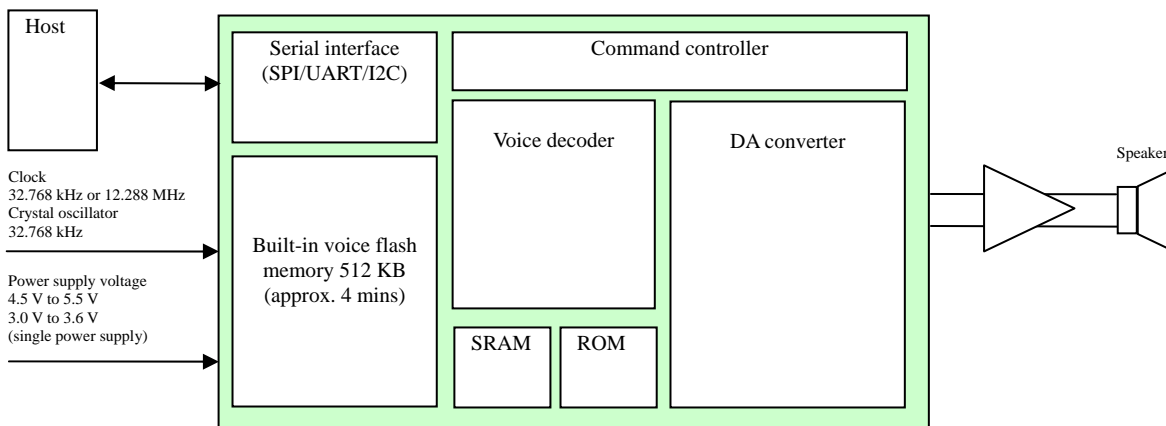

# S1V3S344

## ■ Development Tools

- Evaluation board
- Voice data creation tool<sup>\*2</sup>
- Sample programs

[Voice data creation tool overview]

Step 1: Voice guidance registration

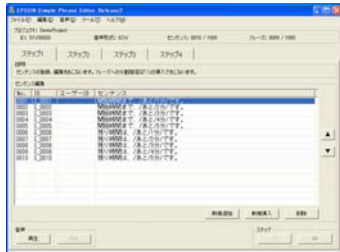

Step 2: Pronunciation editing

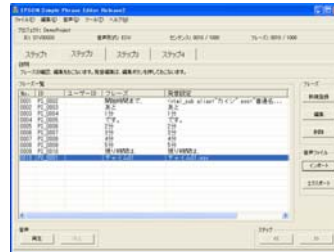

Step 3: Phrase editing

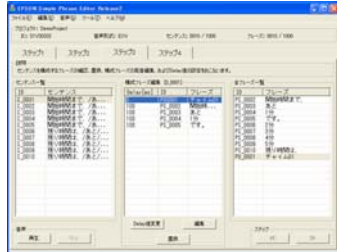

Step 4: ROM data production

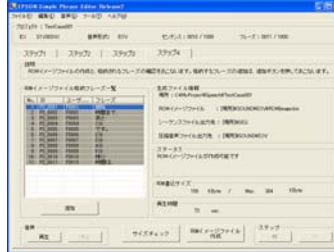

- Supported languages : English, Japanese, Korean (all female voices)  
In planning stage : Spanish, Chinese

\*1 The flash memory technology used in this product is used under license of Silicon Storage Technology, Inc. in the USA.

\*2 The audio data creation tool uses PENTAX "VoiceText" voice synthesis technology. "VoiceText" is a registered trademark of Voiceware Co., Ltd. Companies and product names included here are registered trademarks or trademarks.

### NOTICE:

No part of this material may be reproduced or duplicated in any form or by any means without the written permission of Seiko Epson. Seiko Epson reserves the right to make changes to this material without notice. Seiko Epson does not assume any liability of any kind arising out of any inaccuracies contained in this material or due to its application or use in any product or circuit and, further, there is no representation that this material is applicable to products requiring high level reliability, such as, medical products. Moreover, no license to any intellectual property rights is granted by implication or otherwise, and there is no representation or warranty that anything made in accordance with this material will be free from any patent or copyright infringement of a third party. This material or portions thereof may contain technology or the subject relating to strategic products under the control of the Foreign Exchange and Foreign Trade Law of Japan and may require an export license from the Ministry of Economy, Trade and Industry or other approval from another government agency.

©SEIKO EPSON CORPORATION 2009, All rights reserved.

**SEIKO EPSON CORPORATION**

**SEMICONDUCTOR OPERATIONS DIVISION**

IC Sales Dept.  
IC International Sales Group  
421-8, Hino, Hino-shi, Tokyo 191-8501, JAPAN  
Phone: +81-42-587-5313 FAX: +81-42-587-5116

■ EPSON Electronic devices Website

[http://www.epson.jp/device/semicon\\_e/](http://www.epson.jp/device/semicon_e/)

Document Code: 411676800  
First Issue March 2009 in JAPAN ©

## X-ON Electronics

Largest Supplier of Electrical and Electronic Components

*Click to view similar products for [Communication ICs - Various category](#):*

*Click to view products by [Epson manufacturer](#):*

Other Similar products are found below :

[MT3171BE1](#) [SP-SM2030-0261-01](#) [2100-0320-02](#) [SP-SM2030-0265-004](#) [ZL50232QCG1](#) [ZL38003GMG2](#) [ITM-DYPA-B-01](#) [ITM-DOUF-B-01](#) [ITM-DOPA-B-01](#) [BCM43569PKFFBG](#) [CPC5710NTR](#) [BA8206F-E2](#) [CPC1465D](#) [ZL38002QDG1](#) [MT9126AS1](#) [ML22530TBZ0BX](#) [ML22Q625-NNNTBZ0BX](#) [ML22Q665-NNNTBZ0BX](#) [ML22660TBZ0BX](#) [ML22620TBZ0BX](#) [ML22Q535-NNNTBZ0BX](#) [NB4N7132DTG](#) [LM567CN/NOPB](#) [UCC2750DW](#) [UCC3750DW](#) [CPC5710N](#)