

High-stability Gyro Sensor: X2A000261000814

Features

- SPI / I²C serial interface
- Angular rate output (16/24bit)
- Excellent bias stability over temperature
- Embedded temperature sensor
- Integrated user-selectable digital filter
- Wide supply voltage range 2.7 to 3.6V
- Low power consumption 0.9mA
- Rate range ± 100 °/s
- Pb free
- EU RoHS compliant

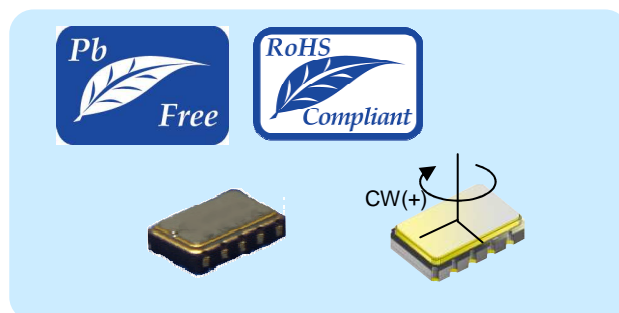

Applications





- Anti-vibration and attitude control for industrial applications etc.
- Motion detection for man machine interface

Description

The XV7001BB feature superior bias output stability and low noise. Epson achieves this performance by using quartz substrates manufactured based on our proprietary QMEMS technology.

In addition to compatibility for digital output interfaces (SPI, I²C), these sensors allow for independent interface power supply voltage settings to enable communications with various interfaces. User-selectable low-pass filters and high-pass filters enable a wide range of cut-off frequencies. Designed for low power consumption, these sensors are suitable for a wide range of uses, from wearable devices and other consumer electronics to industrial equipment.

■ About the symbols used in this catalog

	<ul style="list-style-type: none"> ● A lead-free product.
	<ul style="list-style-type: none"> ● Compliant with the EU RoHS directive. * About products without the Pb-Free label Product terminals are lead-free but the internal components of the product contain lead (high melting point solder lead as well as the lead contained in the glass of an electronic component are both not applicable under the EU RoHS directive).
	<ul style="list-style-type: none"> ● Indicates a product intended for use in an automobile (body, information systems, etc.). The product has been designed and manufactured in accordance with a quality assurance program suited for the on-board environment of an automobile.
	<ul style="list-style-type: none"> ● Indicates a product intended for use to further the safe operation of an automobile (driving, stopping, turning). The product has been designed and manufactured in accordance with a quality assurance program suited for the on-board safety of an automobile.

The following provisions shall apply to the use of this Application Manual.

- (1) The manual provides summary information to serve as reference during your consideration of this product. This manual does not guarantee any product specifications.
- (2) The content of this manual may be changed without notification at any time.
- (3) The unauthorized reproduction, copying, or use for any other purposes of any parts of this manual is strictly prohibited.
- (4) The circuit examples and usage methods indicated in this manual are merely reference information. We make no guarantees whatsoever concerning the possibility of infringement or damages involving third party rights (including industrial property rights) resulting from the use of this information. Furthermore, this manual grants no permission concerning licensing in relation to the industrial property rights of Epson or any third party.
- (5) This manual does not constitute delivery specifications. The use of this product shall require the official exchange of delivery specifications between the company and Epson. In some cases, the information indicated in this manual may vary from actual delivery specifications.
- (6) Of the products indicated in this manual, the export of products defined as regulated substances under the Foreign Exchange and Foreign Trade Control Act requires an export permit issued in accordance with said law.
- (7) This product was designed for use in general consumer products. Prior approval by Epson is required to use this product in the following special applications requiring a particularly high level of reliability. We shall bear no liability whatsoever if this product is used for such purposes without approval.

Space equipment (artificial satellites, rockets, etc.), medical equipment used to maintain life, submarine repeaters, power plant controllers, fire and theft prevention equipment, transportation equipment, and other similar applications requiring a high degree of reliability.

Contents

1. Block diagram	P. 4
2. Functional explanation	P. 5
2-1) Detecting direction		
2-2) Interface		
2-3) Angular rate output		
2-4) Temperature sensor output		
3. Electrical characteristics	P. 6
3-1) Absolute maximum ratings		
3-2) Operating conditions		
3-3) DC Characteristics		
3-4) Operating sequence at Start-up		
3-5) Characteristics		
3-6) Temperature sensor		
4. Dimensions and pin description	P. 10
4-1) Outline dimensions		
4-2) Pin name and description		
4-3) Pin equivalent circuit		
4-4) Soldering pattern		
5. Serial interface	P. 12
5-1) 4-wire SPI		
5-2) 3-wire SPI		
5-3) I ² C		
5-4) Multi-slave function		
5-5) Angular rate data read		
5-6) Temperature sensor output read		
5-7) Control MISO/SA0		
5-8) Command validation time		
6. User command register	P. 31
7. Connection diagram	P. 38
8. Soldering profile	P. 40
9. Terminology	P. 40
10. Handling precaution	P. 41
11. Contact	P. 42

1) Block diagram

The block diagram is indicated below.

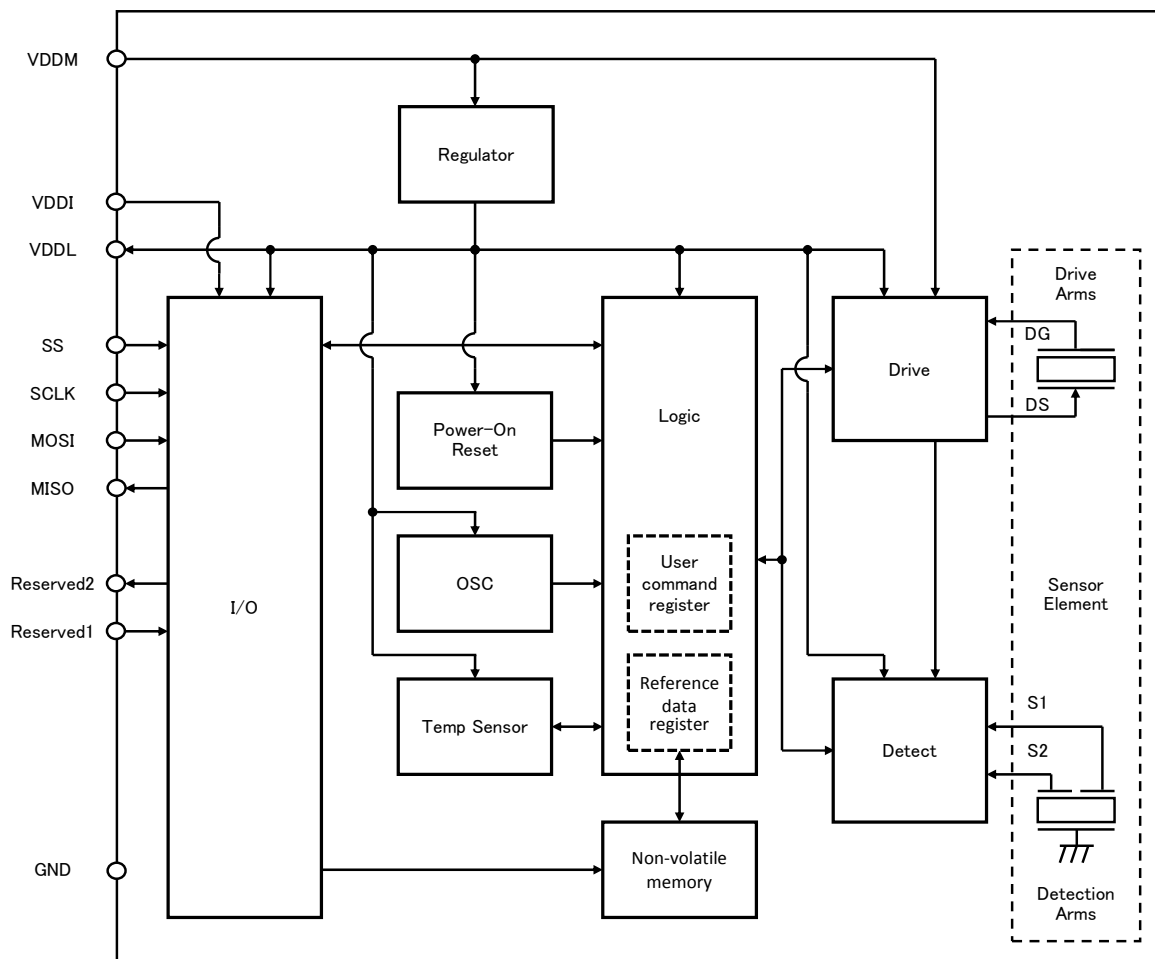

Fig. 1.1 Block diagram

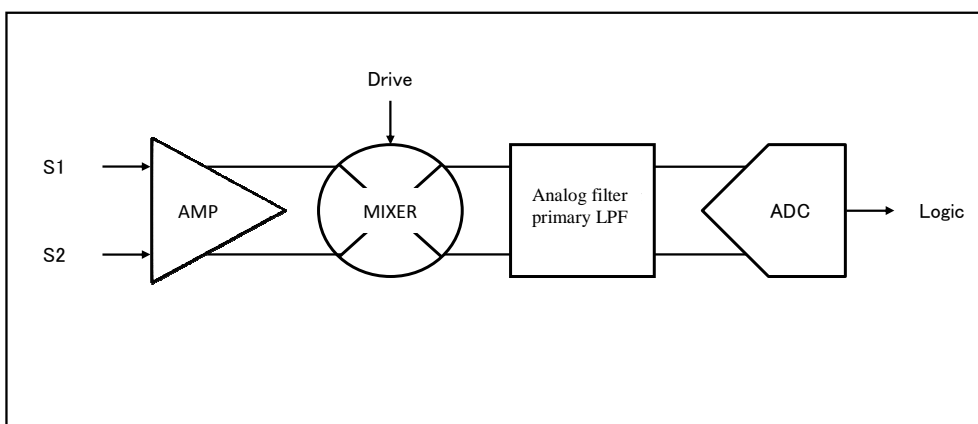
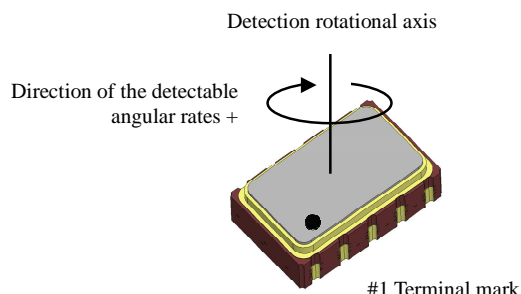

Fig. 1.2 Block diagram of detecting part

2) Functional explanation

2-1) Detecting direction

This product detects the angular rate of rotational movement. The correlation between the angular rate detection axis direction and the detection polarity is shown in the diagram below.



2-2) Interface

Compatibility for SPI (4-wire, 3-wire) and I²C. As an SPI 4-wire mode expansion function, this sensor includes a multi-slave function for use in systems that detect two or more axes at once. This makes it possible to reduce I/O ports and board circuitry. These sensors allow for interface power supply voltage settings (VDDI) that are independent of the power supply voltage (VDDM) to enable communications with interfaces of various logic levels. The multi-slave function is available only through factory settings implemented by Epson.

2-3) Angular rate output

Angular rate data is output in a 2's complement format. 16bit or 24bit can be selected from the register settings. The AD converter sample rate is 13.770 kHz at frequency code H,L and 14.160 kHz at frequency code J. Angular rate data also can be output after processing using the low-pass filter (LPF) or the high-pass filter (HPF).

LPF: The order is 2nd/3rd/4th, the cutoff frequency can be selected from the following 14 stages.
(10/35/45/50/70/85/100/140/175/200/285/345/400/500 [Hz])

HPF: The order is 1st. When enabled, the cutoff frequency can be selected from the following 7 stages.
(0.01/0.03/0.1/0.3/1/3/10 [Hz])

2-4) Temperature sensor output

Temperature data is output in a 2's complement format. 8bit/10bit/12bit can be selected from the register settings.

3) Electrical characteristics

3-1) Absolute maximum ratings

Table 3.1 Absolute maximum ratings

Parameter	Symbol	Standard			Unit	Comment
		Min.	Typ.	Max.		
Supply voltage	VDDM	-0.3		4	V	GND = 0V
Supply voltage for interface	VDDI	-0.3		4	V	GND = 0V
Storage temperature	T _{STG}	-40		85	°C	
Condition for soldering		350 °C 3 s				

3-2) Operating conditions

Table 3.2 Operating conditions

Parameter	Symbol	Standard			Unit	Comment
		Min.	Typ.	Max.		
Supply voltage	VDDM	2.7		3.6	V	GND = 0 V
Supply voltage for interface	VDDI	1.65		3.6	V	GND = 0 V
Operating temperature	T _{OPR}	-20		+80	°C	
Supply voltage start up time	t _{Pu}	0.01		100	ms	VDDM 0% → 90%
4-wire SPI clock frequency				10	MHz	VDDI = 2.4 to 3.6 V
4-wire SPI clock frequency				5	MHz	VDDI = 1.65 to 2.4 V
3-wire SPI clock frequency				5	MHz	VDDI = 1.65 to 3.6 V
I ² C clock frequency				400	kHz	

<Notes>

- Using the drive frequency integral multiplier as communications clock may result in fluctuations in the angular rate output.
- Acquiring angular rate data as a frequency that is a fraction of the integer for the drive frequency can result in fluctuations in the angular rate output.

3-3) DC Characteristics

Table 3.3 DC Characteristics
(VDDM = 2.7 to 3.6 V, VDDI = 1.65 to 3.6 V, GND = 0 V, Ta = -20 to +80 °C)

Parameter	Symbol	Standard			Unit	Note
		Min.	Typ.	Max.		
Logic input voltage	VIH	$VDDI \times 0.7$		-	V	
	VIL	-		$VDDI \times 0.3$	V	
Logic output voltage	VOH	$VDDI - 0.4$		-	V	VDDI=Min., Load = 1 mA
	VOL	-		0.4	V	VDDI=Min., Load = 1 mA

3-4) Operating sequence at Start-up

Table 3.4 Operating sequence at Start-up
(VDDM = 2.7 to 3.6 V, VDDI = 1.65 to 3.6 V, GND = 0 V, Ta = -20 to +80 °C)

Parameter	Symbol	Condition	Standard			Unit
			Min.	Typ.	Max.	
Serial communication wait time	tIF	-	1	-	-	ms
Temperature sensor data read start time	tTSEN	-	-	-	80	ms
Start-up time	tSTA	Output code $\pm 1^\circ/s$	-	-	200	ms

<Notes>

1. Conduct serial communication after tIF.
2. Conduct temperature sensor data acquisition after tTSEN.
3. Conduct angular rate data acquisition after tSTA.

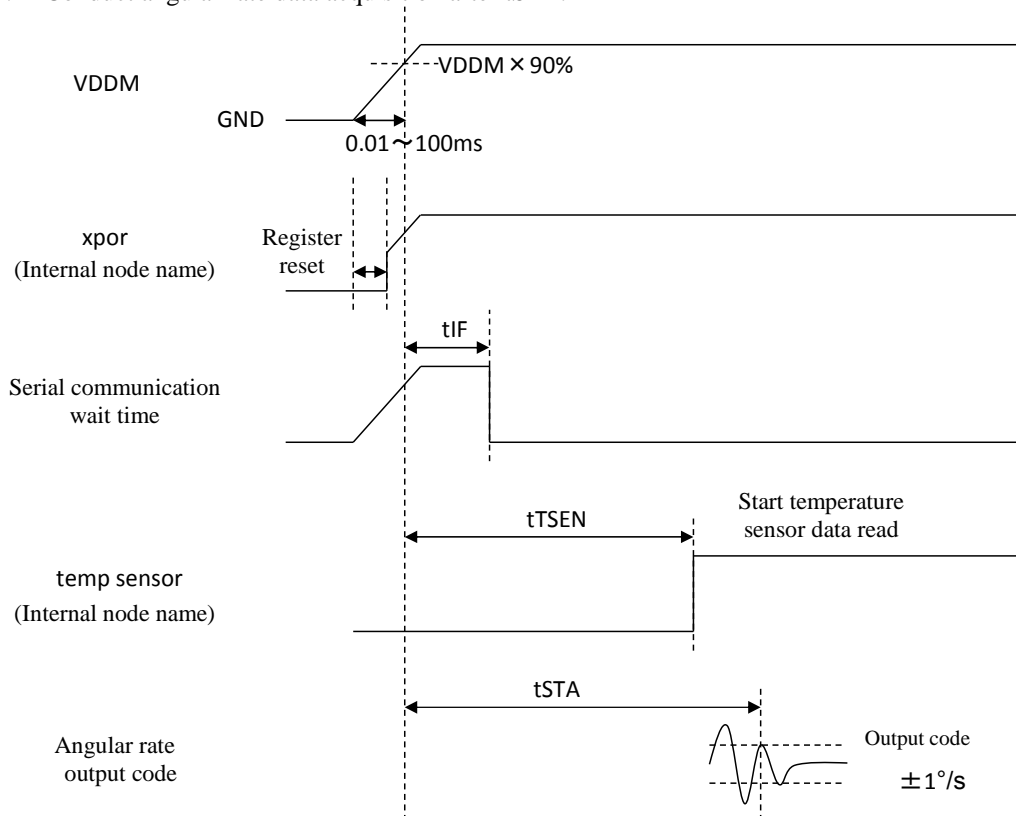

Fig. 3.4 Operating sequence at Start-up

3-5) Characteristics

Table 3.5 Characteristics
 (Unless otherwise specified, VDDM = 2.7 to 3.6 V, VDDI = 1.65 to 3.6 V GND = 0 V, Ta = -20 to +80 °C)

Parameter	Symbol	Condition	Standard			Unit
			Min.	Typ.	Max.	
Drive frequency	Fd	Frequency symbol: H	49.000	49.575	50.150	kHz
		Frequency symbol: J	50.450	51.025	51.600	kHz
		Frequency symbol: L	52.900	53.550	54.200	kHz
Detuning frequency	Df		0.7	0.9	1.1	kHz
Scale factor	So	16bit		280		LSB/(°/s)
		24bit		71680		
Scale factor tolerance	Sp	Ta = +25 °C	-2		+2	%
Scale factor variation over temperature	Spt	VDDM = 3V, Ta = +25 °C standard	-3		+3	%
Bias	ZRL	Ta = +25 °C		0		LSB
Bias tolerance	ZRL	Ta = +25 °C	-1		+1	°/s
Bias variation over temperature	ZRL _t	VDDM = 3V, Ta = +25 °C standard	-5		+5	°/s
Rate range	I		-100		+100	°/s
Non linearity	NI	Ta = +25 °C	-0.5		+0.5	%FS
Cross axis sensitivity	CS	Ta = +25 °C	-5		+5	%
Current consumption	Iop1			900	1300	μA
Stand-by current	Iop2			160	340	μA
Sleep current	Iop3			3	25	μA
Noise density	Nd	@10Hz, LPF default setting		0.003		(°/s)/rtHz

3-6) Temperature sensor

Table 3.6 Temperature sensor

(Unless otherwise specified, VDDM = 2.7 to 3.6 V, VDDI = 1.65 to 3.6 V GND = 0 V, Ta = -20 to +80 °C)

Parameter	Symbol	Condition	Standard			Unit
			Min.	Typ.	Max.	
Output code	Tout	8bit mode, Ta = +25 °C	20	25	30	LSB
		10bit mode, Ta = +25 °C	80	100	120	
		12bit mode, Ta = +25 °C	320	400	480	
Temperature output accuracy	Tacc	Ta = +25 °C	-5		5	°C
Temperature coefficient	Tsen	8bit mode	0.9	1	1.1	LSB/°C
		10bit mode	3.6	4	4.4	
		12bit mode	14.4	16	17.6	

4) Dimensions and pin description

4-1) Outline dimensions

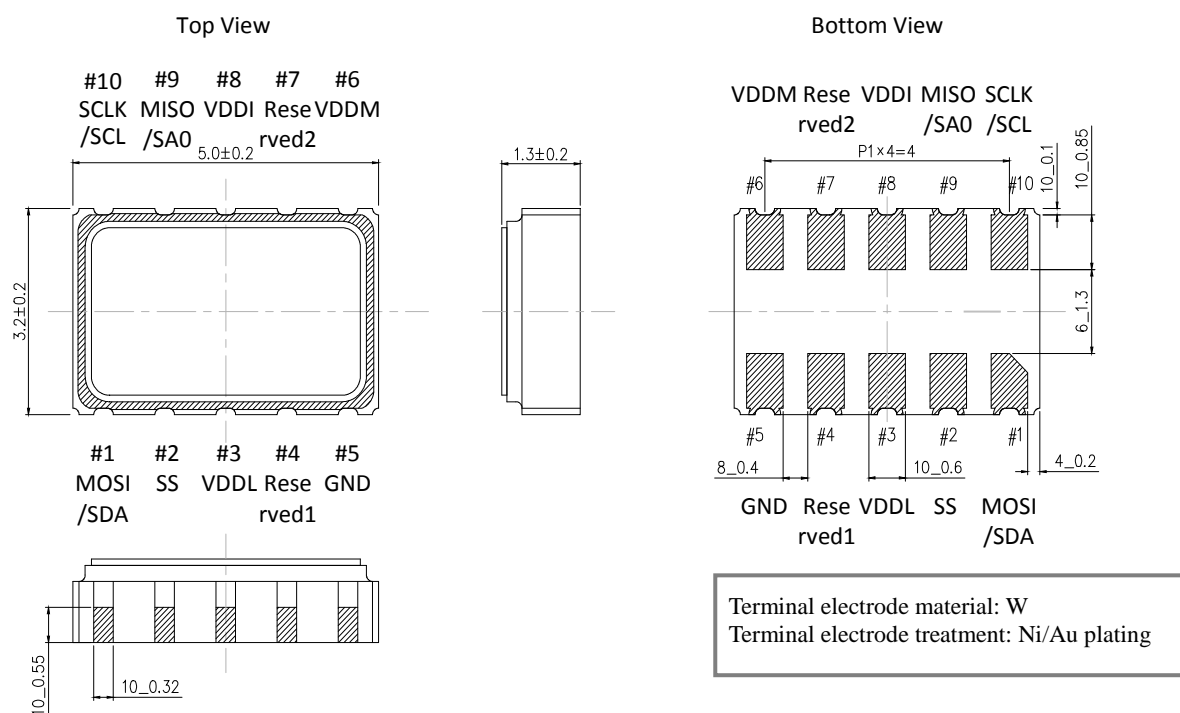

Fig. 4.1 Outline dimensions

4-2) Pin name and description

Table 4.2 Pin name and description

Pin number.	Pin name	I/O	Pin Description
#1	MOSI/ SDA	I/O: Input/Output	4-wire SPI communications mode: serial data input 3-wire SPI communications mode: serial data input/output I ² C communications mode: serial data input/output
#2	SS	I: Input	4-wire SPI communications mode: slave select 3-wire SPI communications mode: slave select I ² C communications mode: connect to VDDI.
#3	VDDL	O: Output	Internal regulator voltage output Connect to the bypass capacitor 1uF.
#4	Reserved1	I: Input	Connect to GND.
#5	GND	-	GND
#6	VDDM	-	Power supply voltage
#7	Reserved2	O: Output	Logic "L" level output Do not connect.
#8	VDDI	-	Power supply voltage for digital interface
#9	MISO/ SA0	I/O: Input / Output	4-wire SPI communications mode: serial data output 3-wire SPI communications mode: Do not connect. I ² C communications mode: select lowest bit of slave address Default status set to pull down (approx. 100 kΩ).
#10	SCLK/ SCL	I: Input	Serial clock (4-wire/3-wire/I ² C)

4-3) Pin equivalent circuit

Equivalent circuit for SS, SCLK, MOSI, MISO and Reserved2 are shown in Fig.4.3.1.

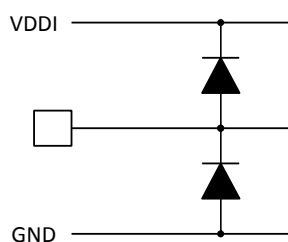

Fig. 4.3.1 Equivalent circuit: SS, SCLK, MISO, Reserved2

Equivalent circuit for VDDL and Reserved1 are shown in Fig.4.3.2.

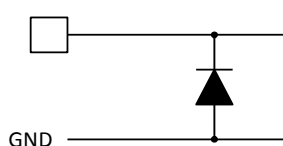

Fig. 4.3.2 Equivalent circuit: VDDL, Reserved1

Equivalent circuit for VDDM and VDDI are shown in Fig.4.3.3.

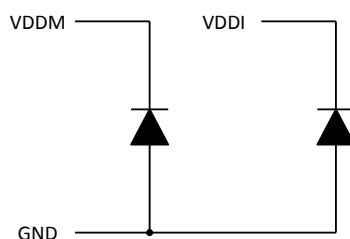

Fig. 4.3.3 Equivalent circuit: VDDM, VDDI

4-4) Soldering pattern

An example of the recommended foot pattern is shown in the following diagram. During actual board design, give due consideration to design aspects such as mounting density and solder mount reliability to ensure optimal design.

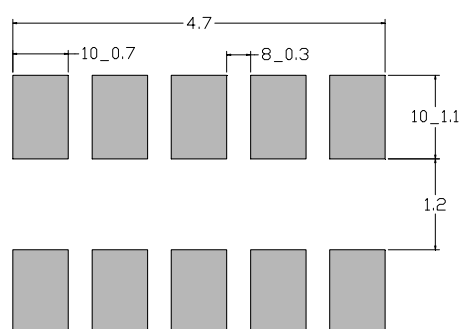

Fig. 4.4 Soldering pattern

5) Serial interface

Access to the sensor is conducted via serial communication. You can select from three methods for the serial interface: 4-wire SPI, 3-wire SPI, or I²C.

4-wire SPI communication is enabled by turning on the power supply VDDM, waiting for the serial communication wait time tIF noted in Section 3-4 to elapse, and then setting the slave select signal (SS) to logic level "L" (because register name SPISel noted in Section 6-14 has a default value of "0": 4-wire SPI). I²C communication is enabled by setting the SS to logic level "H" (because register name I²C_EN noted in Section 6-14 has a default value of "1": I²C enable). 3-wire SPI communication is enabled by setting register name SPISel to "1": 3-wire SPI and setting the SS to logic level "L". However, setting register name SPISel to "1": 3-wire SPI will disable I²C communication.

When the multi-slave function indicated in Section 5-4 is enabled via factory settings, the 4-wire SPI, 3-wire SPI, and I²C functions noted in this section cannot be used.

5-1) 4-wire SPI

4-wire SPI communication is 8-bit width serial communication based on the SS, clock signal (SCLK), data input signal (MOSI), and data output signal (MISO). Set register name SPISel (register for selecting 4-wire SPI/3-wire SPI) indicated in Section 6-14 to "0" (the default value is "0": 4-wire SPI). To use 4-wire SPI communication, set register name I²C_EN (register for enabling I²C) to "0" disable (default value is "1": enable).

The SS falls and the initial byte becomes the address. During serial data transfer, the SS must be maintained at logic level "L." If the SS is set to logic level "H," the serial data transfer will be canceled.

The initial address bit (MSB) is the write/read control bit. Set as "0" to write data to the register and set as "1" to read data from the register.

The subsequent bit 2 (A[6: 5]) is the slave device (Gyro) address when the multi-slave function is enabled. Refer to Section 5-4(Multi-Slave Function) and transfer the address of the slave device (Gyro) you want to access. Set to "00" when the multi-slave function is disabled.

Bit 5 (A<4: 0>) on the LSB side of the address is the register address. Set the address of the register you want to access. The 2nd byte is the settings value for each register. Refer to the register map in Chapter 6 and transfer the values you want to set.

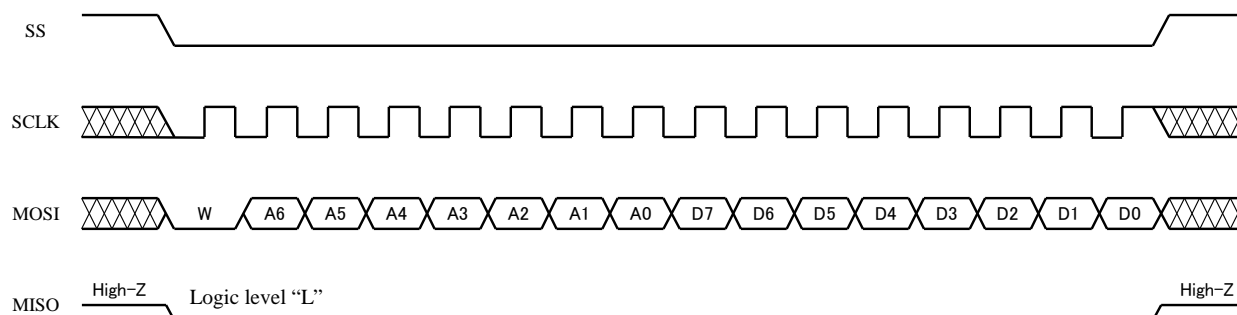

Fig. 5.1.1 Writing to a Register

The register write sequence is shown in Fig. 5.1.1. Write data is transferred after the address. Maintain the SS at logic level "L" during the period between address and data transfer. During the write sequence, the MISO logic level is output as "L." X is "1" or "0."

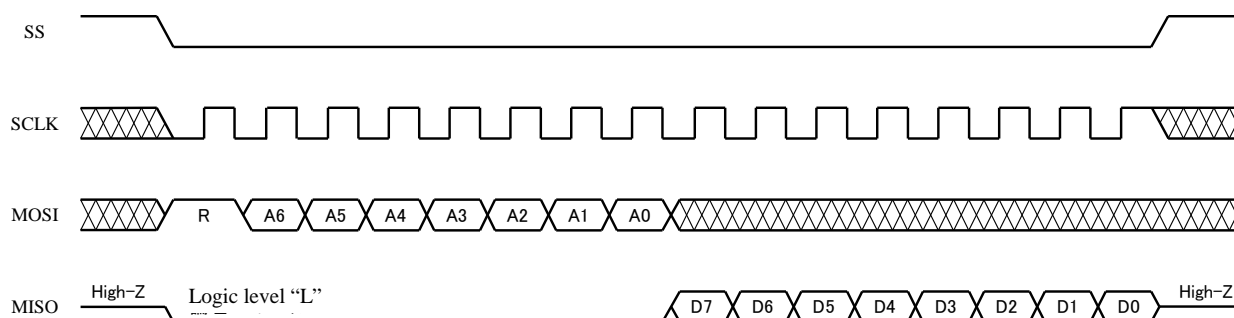

Fig. 5.1.2 Reading a Register

The register read sequence is shown in Fig. 5.1.2. After the address transfer is complete, data is output simultaneously with SCLK fall beginning from the 2nd byte. Similar to the write sequence, during data non-output, the MISO logic level is output as "L." X is "1" or "0." Angular rate data reads are based on 16-bit output (or 24-bit output based on the angular rate data format selection indicated in Chapter 6). After reading the angular rate data from the 1st byte, maintain logic level "L" for the SS and continue clock input via the SCLK until the desired bit is read (the same applies to reading the temperature sensor data).

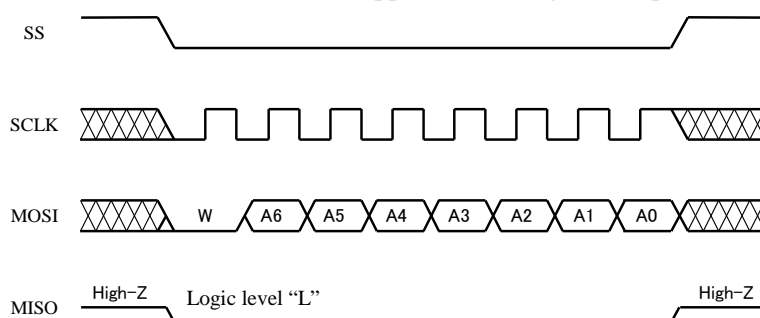

Fig. 5.1.3 Specifying an Address (Command)

The sequence for only the address transfer (command) is shown in Fig. 5.1.3. The register map indicated in Chapter 6 includes the items for only a partial address transfer (command). Similar to the register write sequence, set the first bit (MSB) of the address to "0." Bit 5 (A<4: 0>) on the LSB side of the address is the register address (command). Set the address (command) you want to execute. After transferring the address (command), set the SS from logic level "L" to logic level "H" and end the serial communication. During the address transfer sequence, the MISO logic level is output as "L." X is "1" or "0."

The timing chart is indicated below.

Table 5.1.1 4-wire SPI_AC characterisitc
(VDDM = 2.7 to 3.6 V, GND = 0 V, Ta = -20 to +80 °C)

Parameter	Symbol	Condition	Standard						Unit
			VDDI = 1.65 to 2.4 V			VDDI = 2.4 to 3.6 V			
			Min.	Typ.	Max.	Min.	Typ.	Max.	
SS setup time	tSSS		15	-	-	15	-	-	ns
SS hold time	tSSH		100	-	-	100	-	-	ns
SS high pulse width	tSSHW		30	-	-	30	-	-	ns
Clock cycle	tSCYC		200	-	-	100	-	-	ns
Clock high pulse width	tSHW		90	-	-	40	-	-	ns
Clock low pulse width	tSLW		90	-	-	40	-	-	ns
Data setup time	tSDS		10	-	-	10	-	-	ns
Data hold time	tSDH		10	-	-	10	-	-	ns
Read access time	tSACC	Max CL = 30 pF	-	-	80	-	-	30	ns
Output disable time	tSOH		-	-	30	-	-	30	ns

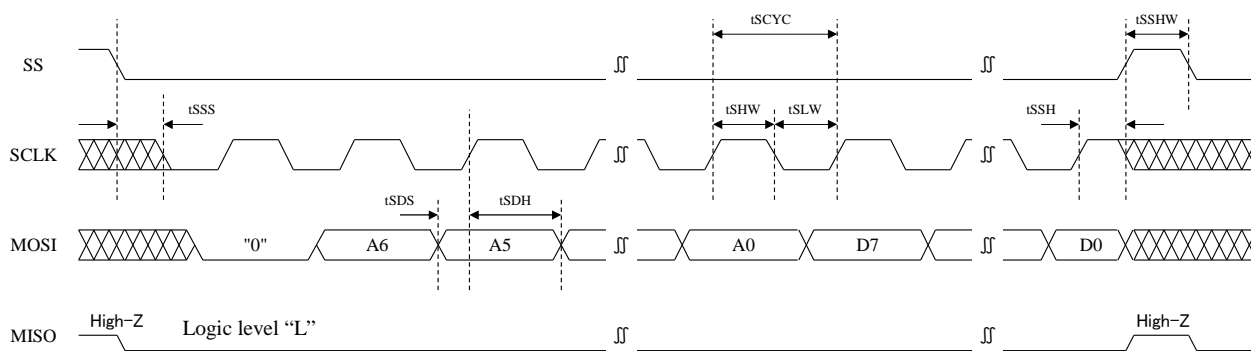

Writing to the 4-wire SPI Register

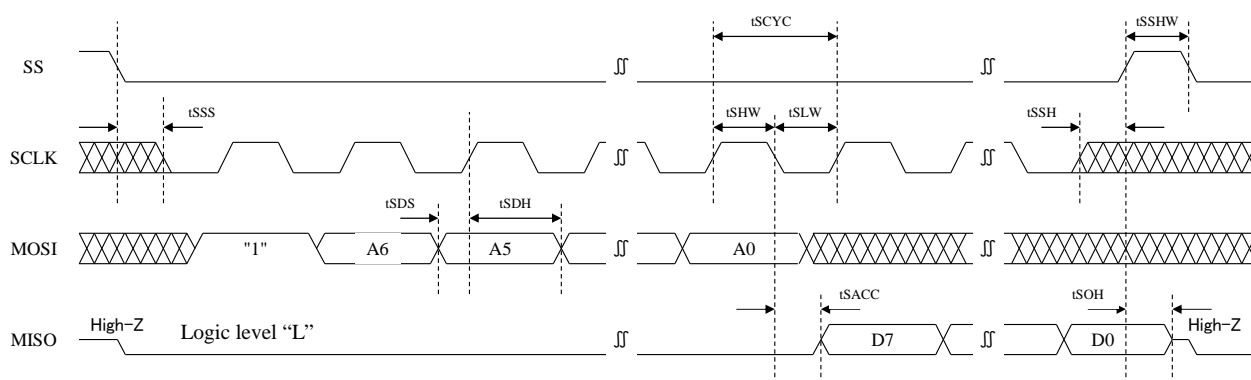

Reading the 4-wire SPI Register

(Note) X is "1" or "0."

5-2) 3-wire SPI

3-wire SPI communication is 8-bit width serial communication based on the slave select signal (SS), clock signal (SCLK), and data input/output signal (MOSI). Set register name SPISel (register for selecting 3-wire SPI/4-wire SPI) indicated in Chapter 6 (Table 6.14 Serial Interface Settings) to "1" (the default value is "0": 4-wire SPI). Setting SPISel to "1" will disable I²C communication.

Similar to 4-wire SPI, the SS falls and the initial byte becomes the address. During serial data transfer, the SS must be maintained at logic level "L." If the SS is set to logic level "H," the serial data transfer will be canceled.

The initial address bit (MSB) is the write/read control bit. Set as "0" to write data to the register and set as "1" to read data from the register. Bit 5 (A<4: 0>) on the LSB side of the address is the register address. Set the address of the register you want to access. The 2nd byte is the settings value for each register. Refer to the register map in Chapter 6 and transfer the values you want to set.

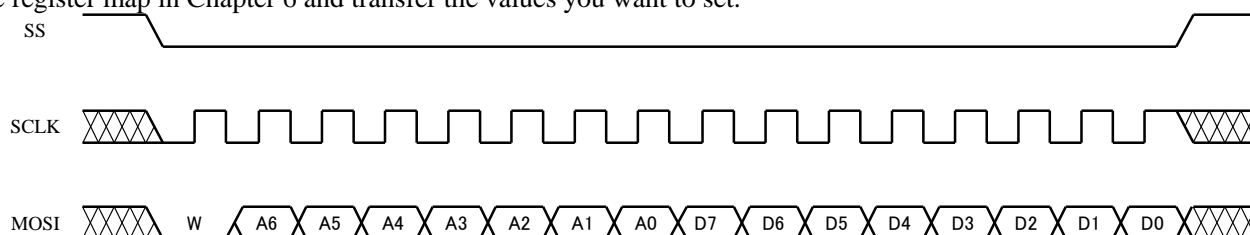

Fig. 5.2.1 Writing to a Register

The register write sequence is shown in Fig. 5.2.1. Write data is transferred after the address. Maintain the SS at logic level "L" during the period between address and data transfer. X is "1" or "0."

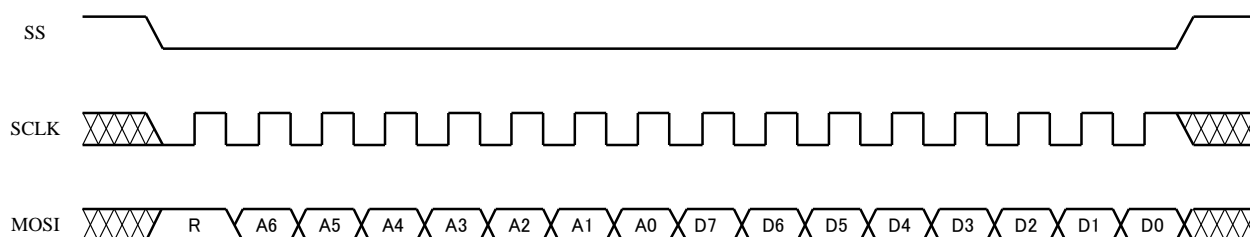

Fig. 5.2.2 Reading a Register

The register read sequence is shown in Fig. 5.2.2. After the address transfer is complete, data is output simultaneously with SCLK fall beginning from the 2nd byte. Angular rate data reads are based on 16-bit output (or 24-bit output based on the angular rate data format selection indicated in Chapter 6). After reading the angular rate data from the 1st byte, maintain the SS at logic level "L" and continue clock input via the SCLK until the desired bit is read. The same applies to reading the temperature sensor data. X is "1" or "0."

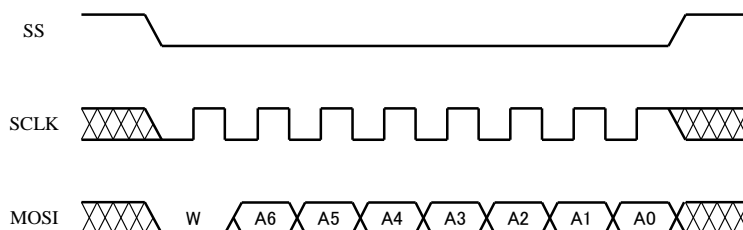

Fig. 5.2.3 Specifying an Address (Command)

The sequence for only the address transfer (command) is shown in Fig. 5.2.3. The register map indicated in Chapter 6 includes the items for only a partial address transfer (command). Similar to the register write sequence, set the first bit (MSB) of the address to "0." Bit 5 (A<4: 0>) on the LSB side of the address is the register address (command). Set the address (command) you want to execute. After transferring the address (command), set the SS from logic level "L" to logic level "H" and end the serial communication. X is "1" or "0."

The timing chart is indicated below.

Table 5.2.1 3-wire SPI_AC characterisitic
(VDDM = 2.7 to 3.6 V, GND = 0 V, Ta = -20 to +80 °C)

Paramter	Symbol	Condition	Standard						Unit
			VDDI = 1.65 to 2.4 V			VDDI = 2.4 to 3.6 V			
			Min.	Typ.	Max.	Min.	Typ.	Max.	
SS setup time	tSSS		15	-	-	15	-	-	ns
SS hold time	tSSH		100	-	-	100	-	-	ns
SS high pulse width	tSSHW		30	-	-	30	-	-	ns
Clock cycle	tSCYC		200	-	-	100	-	-	ns
Clock high pulse width	tSHW		90	-	-	40	-	-	ns
Clock low pulse width	tSLW		90	-	-	40	-	-	ns
Data setup time	tSDS		10	-	-	10	-	-	ns
Data hold time	tSDH		10	-	-	10	-	-	ns
Read access time	tSACC	Max CL = 30 pF	-	-	80	-	-	80	ns
Output disable time	tSOH		-	-	30	-	-	30	ns

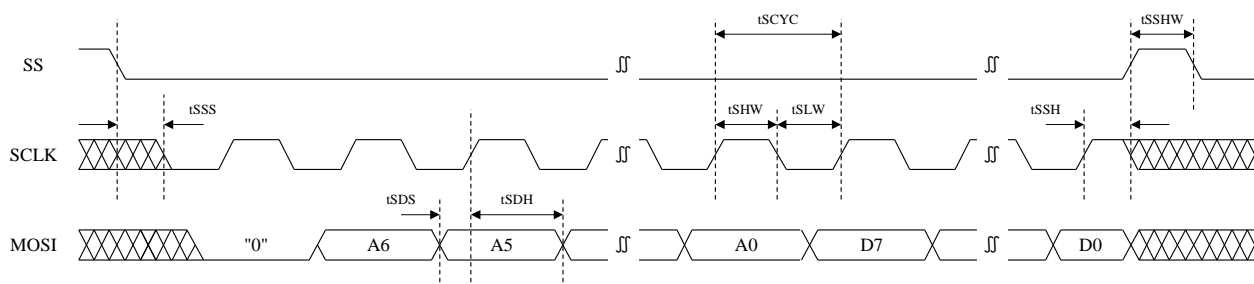

Fig. 5.2.4 Writing to the 3-wire SPI Register

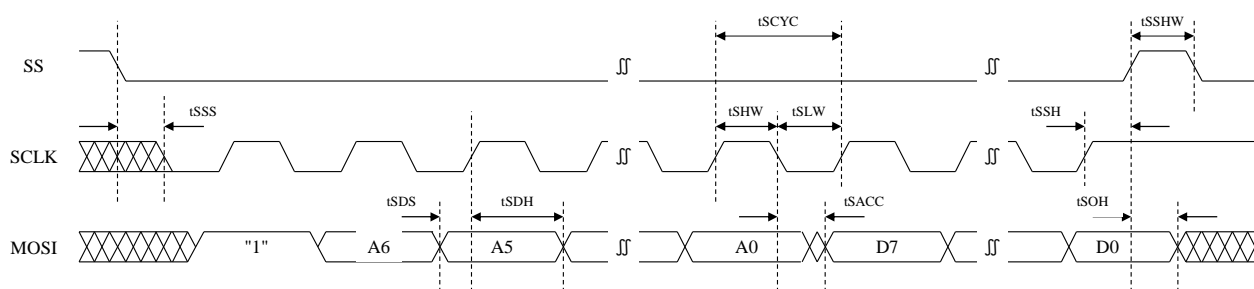

Fig. 5.2.5 Reading the 3-wire SPI Register

(Note) X is "1" or "0."

5-3) I²C

I²C communication is 8-bit width serial communication based on the clock signal (SCL) and data address signal (SDA). Set register name I²C_EN (register enabling for I²C) indicated in Chapter 6 (Table 6.14 Serial Interface Settings) to "1" (the default value is "1": Enable). To use I²C communication, fix the slave select signal (SS) used in 4-wire/3-wire SPI communication to logic level "H" (interface power supply voltage VDDI).

I²C communication is initiated by issuing the start condition (ST, with SCL status at logic level "H", SDA is changed from logic level "H" to logic level "L") from the master. Or, communication is stopped by issuing the stop condition (SP, with SCL status at logic level "H", SDA is changed from logic level "L" to logic level "H") from the master.

To access the internal register, read (Read="1")/write (Write="0") the slave device address (ADR, address that adds the SA0 "0" or "1" to "110101") to/from the master and transmit the total 1 byte that includes 1 bit ID signal. After ADR receipt, the slave will check to see if the address matches its own address. If matching, the slave returns an ACK (acknowledge), after which communication is possible. If the address does not match, the slave returns to idle mode and waits until another ST is issued.

Internally, the SA0 terminal is set to pull down (approx. 100 kΩ). If the SA0 terminal is set to "0," then connect to N.C. or GND. Or, if the SA0 terminal is set to "1," then connect to VDDI. In this case, a current of approximately 30 uA @VDDI = 3V will flow to the SA0 terminal. To reduce the current, add a desired resistor to the VDDI and SA0 terminal. Alternatively, you can change the terminal setting from pull down to pull up by rewriting the register name SelMISO[1: 0] indicated in Section 6-13 after turning the power ON and once the serial communication wait time tIF indicated in Section 3-4 has elapsed. Refer to Section 5-7 MISO/SA0 Terminal Control Methods for details on control methods.

Next, send the internal register address (SUB-ADR). Input "0" for the first bit (MSB) of the address (there is not function allocation). The remaining LSB-side 7 bits (A<6: 0> are the register address (for detail, refer to register map in Chapter 6). After transferring the address of the register you wish to access, return an ACK.

The following sequence differs between register write, register read, and address (command) transfer. Refer to the sequences in Table 5.3.1 through 5.3.3.

Angular rate data reads are based on 16-bit output (or 24-bit output based on the angular rate data format selection indicated in Chapter 6). After reading the angular rate data from the 1st byte, set the master to return an ACK (acknowledge) instead of an NACK (non-acknowledge) and then read the 2nd byte or the 3rd byte. The same applies to reading the temperature sensor data.

Table 5.3.1 Writing to a Register

Master	ST	ADR	W	SUB-ADR	DATA	SP
Slave				ACK	ACK	ACK

Table 5.3.2 Reading a Register

Master	ST	ADR	W	SUB-ADR	ST	ADR	R	NACK	SP
Slave				ACK				ACK	DATA

Table 5.3.3 Specifying an Address (Command)

Master	ST	ADR	W	SUB-ADR	SP
Slave				ACK	ACK

ST : start condition
 SP : stop condition
 ADR : slave device address (110101+SA0)

R/W : Read = "1", Write = "0"
 SUB-ADR : internal register address
 DATA : internal register read/write data
 ACK : "Low"
 NACK : "High," send at read complete.

As an example of a waveform, register write, register read, and address (command) transfer are shown in Fig. 5.3.4 through 5.3.6.

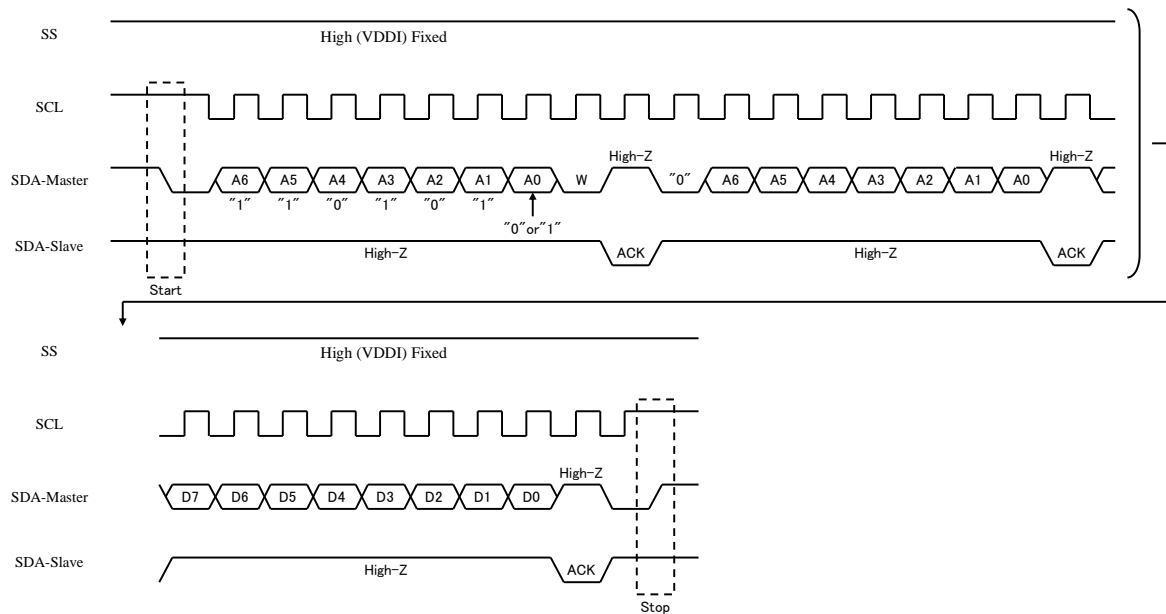

Fig. 5.3.4 Writing to a Register

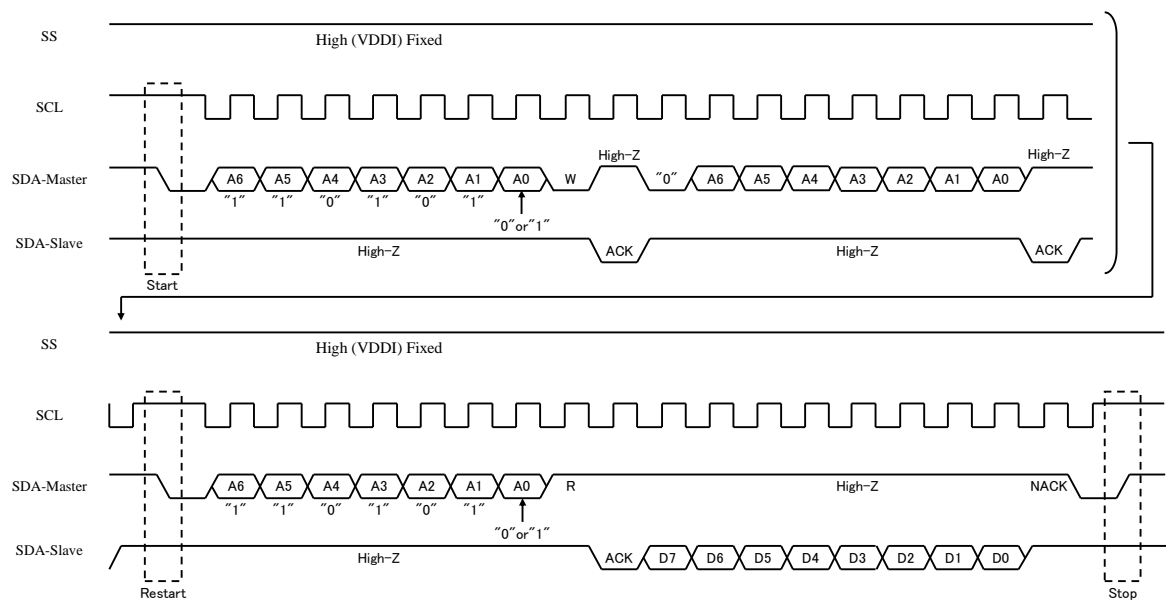

Fig. 5.3.5 Reading a Register

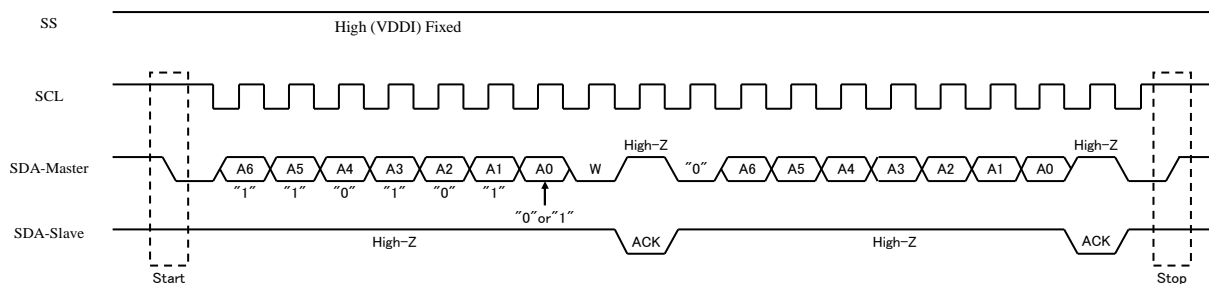

Fig. 5.3.6 Specifying an Address (Command)

The timing chart is indicated below.

Table 5.3.1 I²C_AC characteristic
(VDDM = 2.7 to 3.6 V, GND = 0 V, Ta = -20 to +80 °C)

Parameter	Symbol	Conditions	Standard			Unit
			Min.	Typ.	Max.	
Clock cycle	tSCL		2.5	-	-	us
Clock high pulse width	tWH		0.6	-	-	us
Clock low pulse width	tWL		1.3	-	-	us
Data setup time	tDS		0.1	-	-	us
Data hold time	tDH		0.0	-	-	us
START condition hold time	tSH		0.6	-	-	us
Time restart condition setup time	tRS		0.6	-	-	us
STOP condition setup time	tPS		0.6	-	-	us
Between STOP and START condition	tWS		1.3	-	-	us

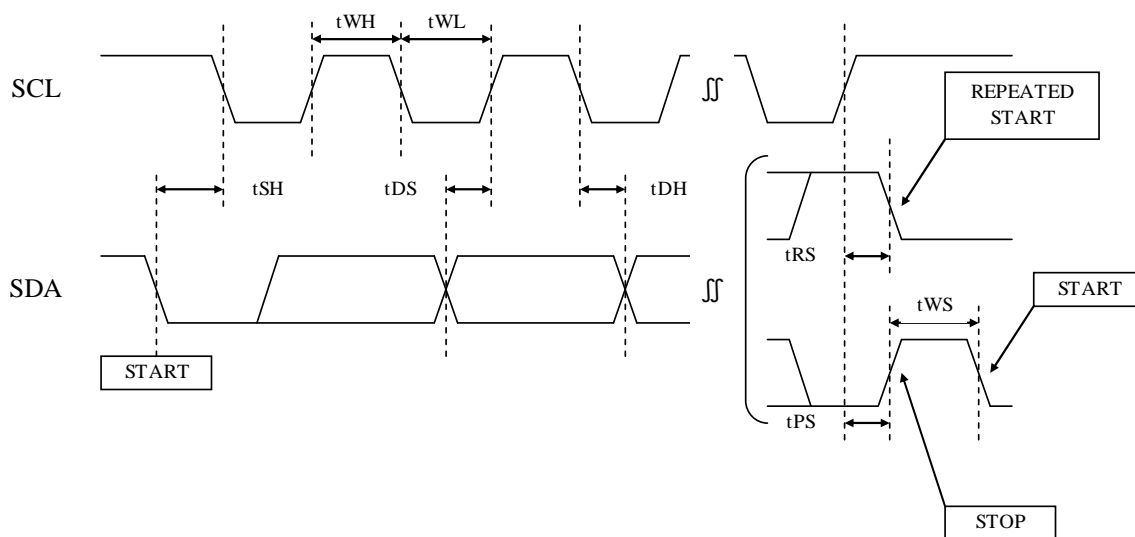

Fig. 5.3.7 I²C timing

5-4) Multi-slave function

The multi-slave function is an extended function of SPI 4-wire mode that is available only through factory settings implemented by Epson. The multi-slave function allows you to reduce I/O ports and board circuitry by connecting multiple (maximum of 3) slave devices (Gyro) to a single master device (MPU). When the multi-slave function is enabled via factory settings, other serial communication (4-wire SPI, 3-wire SPI, and I²C communication) cannot be used.

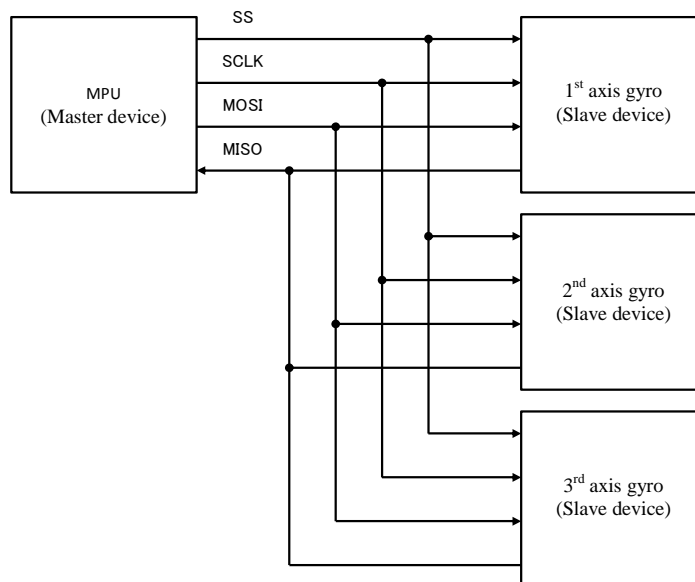

Fig. 5.4.1 Connection Examples

A connection example using 3 slave devices is shown in Fig. 5.4.1. Three slave devices (Gyro) share a serial communications port connection on a single master device (MPU).

Each slave device (Gyro) is assigned the respective address shown in Table 5.4.1. Setting the address A[6: 5] indicated in Chapter 5 enables serial communication with the desired slave device.

Table 5.4.1 Slave Device Addresses

A[6]	A[5]	Selected slave device
0	0	All slave devices
0	1	1st axis Gyro (frequency symbol H)
1	0	2nd axis Gyro (frequency symbol J)
1	1	3rd axis Gyro (frequency symbol L)

(Note) When the maximum 3 slave devices are connected

Furthermore, when the address A[6: 5] is set to "00", a register write command will write the same data to all slave devices but register read commands are not common to all devices. Even if the read/write control bit (first bit of address: MSB) indicated in Chapter 5 is mistakenly set to "1" (read), the MISO value is "High-Z" (excluding global angular rate reads).

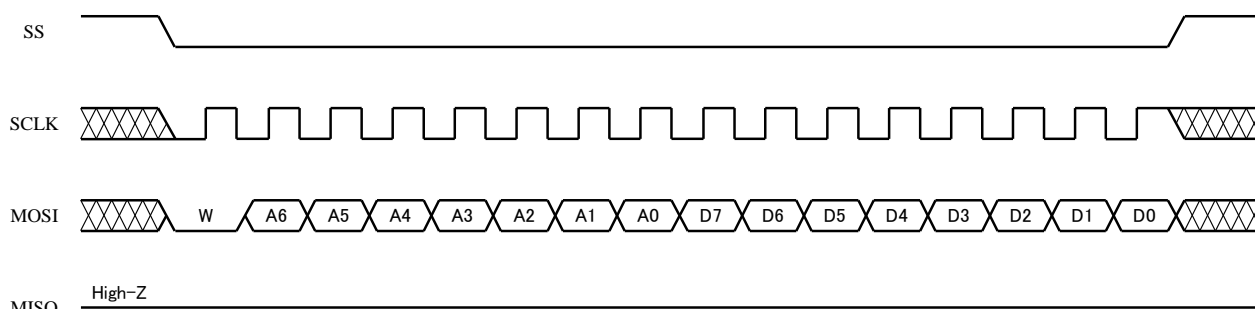

Fig. 5.4.2 Writing to a Register

The register write sequence when using the multi-slave function is shown in Fig. 5.4.2. Write data is transferred after the slave device address and register address. Maintain the SS at logic level "L" during the period between address and data transfer. During the write sequence, the MISO value is "High-Z". X is "1" or "0".

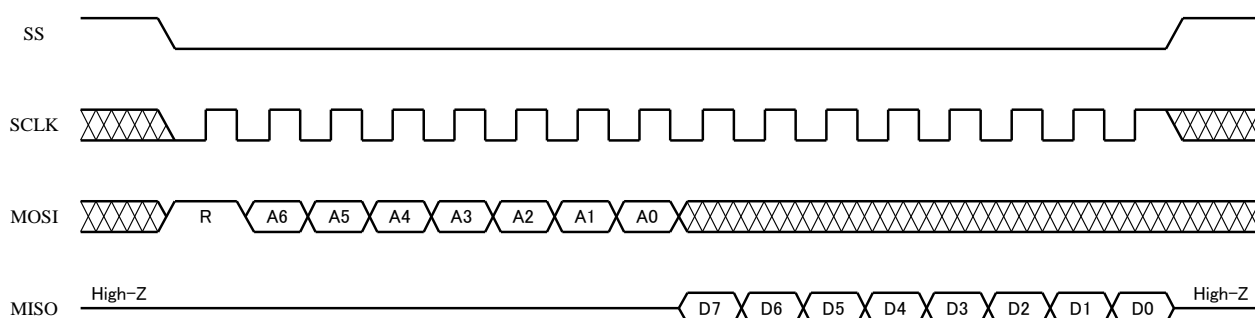

Fig. 5.4.3 Reading a Register

The register read sequence when using the multi-slave function is shown in Fig. 5.4.3. After the slave device address and register address transfer is complete, data is output simultaneously with SCLK fall beginning from the 2nd byte. Similar to the write sequence, during data non-output, the MISO setting is "High-Z". X is "1" or "0". Angular rate data reads are based on 16-bit output (or 24-bit output based on the angular rate data format selection indicated in Chapter 6). After reading the angular rate data from the 1st byte, maintain logic level "L" for the SS and continue clock input via the SCLK until the desired bit is read (the same applies to reading the temperature sensor data).

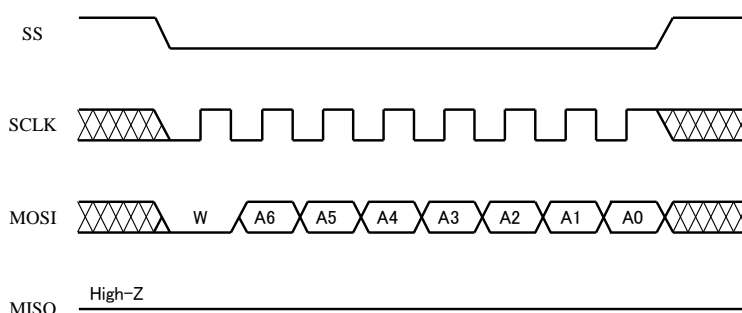

Fig. 5.4.4 Specifying an Address (Command)

The sequence for only the address transfer (command) via the multi-slave function is shown in Fig. 5.4.4. Maintain the SS at logic level "L" during address transfer. During the address transfer sequence, the MISO value is "High-Z". X is "1" or "0".

The timing chart is indicated below.

Table 5.4.2 4-wire SPI multi slave_AC characteristic
(VDDM = 2.7 to 3.6 V, GND = 0 V, Ta = -20 to +80 °C)

Parameter	Symbol	Condition	Standard						Unit
			VDDI = 1.65 to 2.4 V			VDDI = 2.4 to 3.6 V			
			Min	Typ	Max	Min	Typ	Max	
SS setup time	tSSS		15	-	-	15	-	-	ns
SS hold time	tSSH		100	-	-	100	-	-	ns
SS high pulse width	tSSHW		30	-	-	30	-	-	ns
Clock cycle	tSCYC		200	-	-	100	-	-	ns
Clock high pulse width	tSHW		90	-	-	40	-	-	ns
Clock low pulse width	tSLW		90	-	-	40	-	-	ns
Data setup time	tSDS		10	-	-	10	-	-	ns
Data hold time	tSDH		10	-	-	10	-	-	ns
Read access time	tSACC	Max CL = 30 pF	-	-	80	-	-	30	ns
Output disable time	tSOH		-	-	30	-	-	30	ns

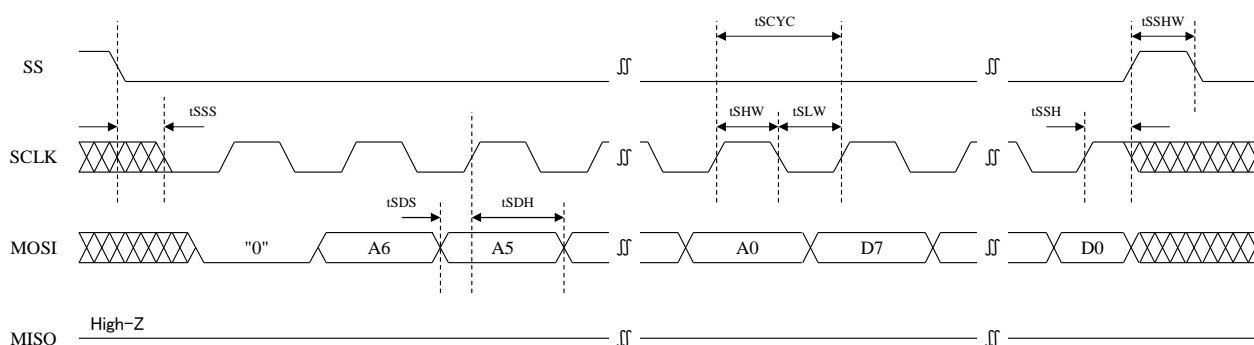

Fig. 5.4.5 Writing to a Register

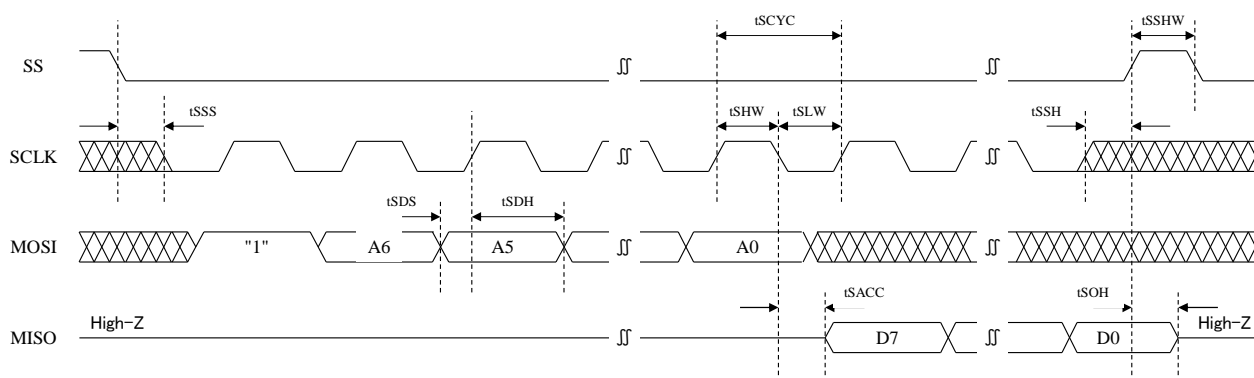

Fig. 5.4.6 Reading a Register

(Note 1) X is "1" or "0".

5-5) Angular rate data read

5-5-1) SPI / I²C serial interface (When multi-slave function is disabled)

The angular rate read function is conducted using the register name DatAccOn indicated in Chapter 6 (Table 6 User Command Register). Angular rate data uses the 2's compliment expression and has a data width of 16 bit or 24 bit (switch using the register name DataFormat indicated in Table 6.11). During serial communication, after reading the angular rate data from the 1st byte, maintain logic level "L" for the SS and continue clock input via the SCLK until the desired bit is read.

Table 5.1 Angular rate data output control

A[6: 5]	Data Format	Data output order		
		1byte	2byte	3byte
00	0	D[15: 8]	D[7: 0]	
↑	1	D[23: 16]	D[15: 8]	D[7: 0]

(Note) Register name DataFormat is the angular data format (DataFormat = 0: 16bit output/1: 24bit output) indicated in Chapter 6 (Table 6.11 Angular rate data read control)

When 4-wire SPI/ 3-wire SPI communication mode, after reading the angular rate data from the 1st byte, maintain logic level "L" for the SS and continue clock input via the SCLK until the desired bit is read.

When I²C communication mode, after reading the angular rate data from the 1st byte, set the master to return an ACK (acknowledge) instead of an NACK (non-acknowledge) and then read the 2nd byte or the 3rd byte.

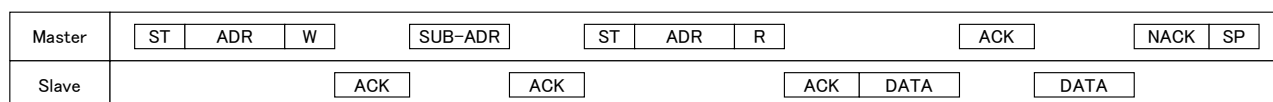

Fig. 5.5.1.1 Angular rate data (16bit output)

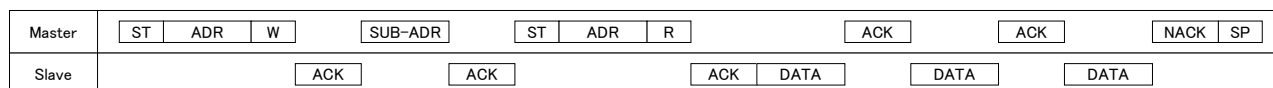

Fig. 5.5.1.2 Angular rate data (24bit output)

5-5-2) When multi-slave function is enabled

The angular rate read function is conducted using the register name DatAccOn indicated in Chapter 6 (Table 6. User Command Register). Angular rate data uses the 2's compliment expression and has a data width of 16 bit or 24 bit (switch using the register name DataFormat indicated in Table 6.11). There are two read methods, global angular rate read and normal angular rate read.

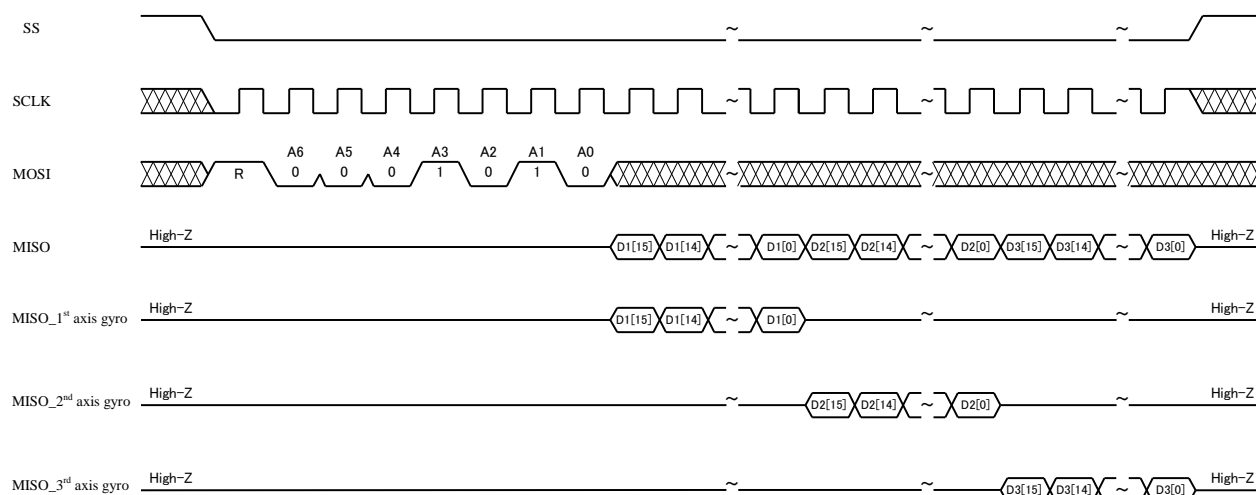

Fig. 5.5.2.1 Global angular rate read

Global angular rate read is shown in Fig. 5.5.2.1. To conduct a global angular rate read, set the slave device address A[6: 5] to "00". After the angular rate data for the 1st axis gyro, the angular rate for the 2nd gyro and then the 3rd gyro are output. During serial communication, maintain logic level "L" for the SS and continue clock input via the SCLK until the desired bit is read. If the logic level for the SS is changed from "L" to "H" before the desired bit is read, then no further angular rate data is output. Redo the angular rate data read command (DatAccOn).

If the SCLK is stopped with the SS level maintained at level "L" before the desired bit is read, the angular rate data read can be output by restarting the SCLK input.

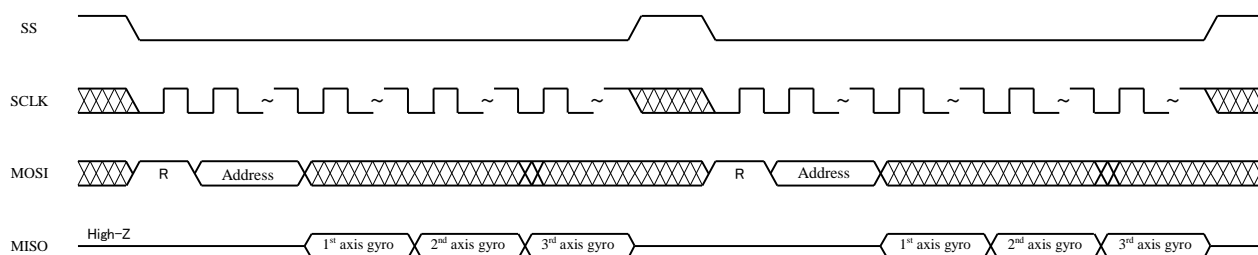

Fig. 5.5.2.2 Global angular rate read operation method 1

Global angular rate read operation method 1 is shown in Fig. 5.5.2.2. After the angular rate data for the 1st axis gyro, the angular rate for the 2nd gyro and then the 3rd gyro are output. After the desired bit is read, raise the SS from logic level "L" to logic level "H." Run the angular rate data read command (DatAccOn) to read the angular rate data again.

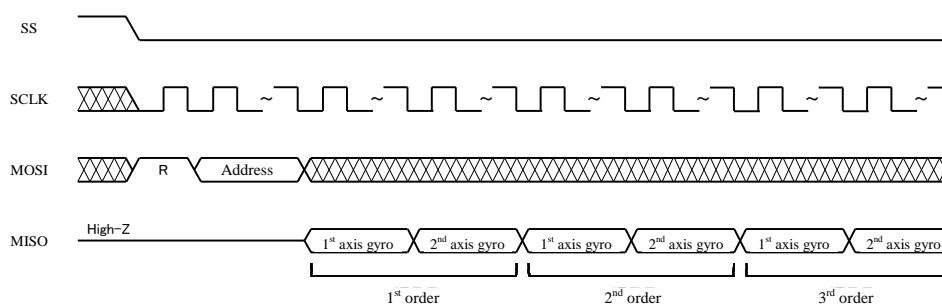

Fig. 5.3.2.3 Global angular rate read operation method 2 (2-axis setting)

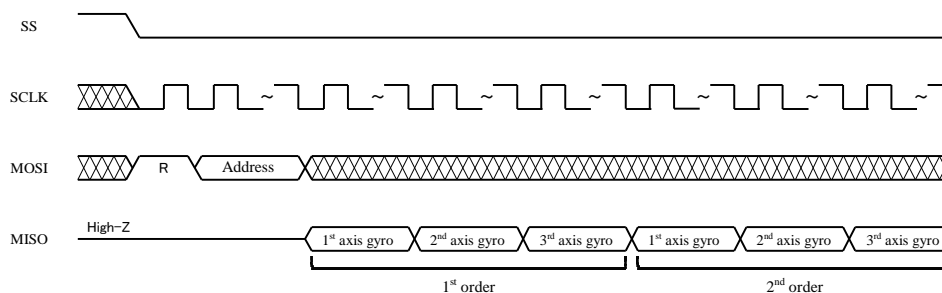

Fig. 5.3.2.4 Global angular rate read operation method 2 (3-axis setting)

Table 5.5.2.1 Global angular rate read operation method 2 - Data output order

Epson factory settings	Data output order					
	1st order		2nd order		3rd order	
2-axis setting	1st axis gyro	2nd axis gyro	1st axis gyro	2nd axis gyro	1st axis gyro	2nd axis gyro
	1st order			2nd order		
3-axis setting	1st axis gyro	2nd axis gyro	3rd axis gyro	1st axis gyro	2nd axis gyro	3rd axis gyro

For the global angular rate read operation method 2, 2-axis settings (Epson factory settings) are shown in Fig. 5.5.2.3 and 3-axis settings (Epson factory settings) are shown in Fig. 5.5.2.4. The data output order is shown in Table 5.5.2.1. After the angular rate data for the 2-axis or 3-axis gyro is output, input the SCLK with the SS logic level at "L" to output the 2nd order angular rate data (1st - 2nd gyro or 1st - 3rd gyro). This angular rate data read can be repeated in the order of 3rd, 4th until the SS logic level is set to "H"

The read angular rate data update is conducted during the read period for the lower 8 bits of the angular rate data of the previous axis (ex: when using a 3-axis setting, the angular rate data for 1st axis gyro of the 2nd order is updated during the read period for the lower 8 bits of angular rate data from the 3rd axis gyro of the 1st order).

There are two global angular rate read types, 2-axis setting and 3-axis setting (both Epson factory settings). Mistakenly mixing the gyro for the 2-axis and 3-axis settings will result in a conflict in the output angular rate data.

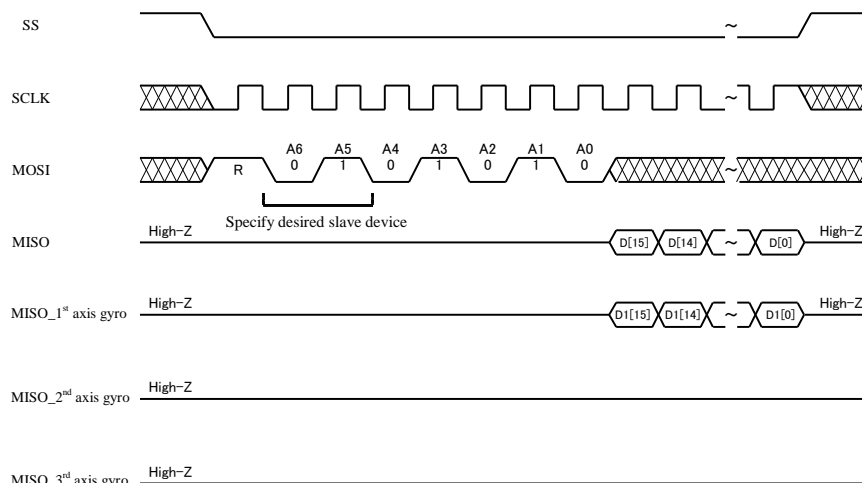

Fig. 5.5.2.5 Normal angular rate read

Normal angular rate read is shown in Fig. 5.5.2.5. For the slave device address A[6: 5] used during normal angular rate read, set a desired slave device address (any of the Gyro addresses for the 1st through 3rd axes) from the addresses indicated in Chapter 5 (Table 5.4.1 Slave Device Addresses). During serial communication, maintain logic level "L" for the SS and continue clock input via the SCLK until the desired bit is read. If the logic level for the SS is changed from "L" to "H" before the desired bit is read, then no further angular rate data is output. Redo the angular rate data read command (DatAccOn).

If the SCLK is stopped with the SS logic level maintained at "L" before the desired bit is read, the angular rate data output can be continued by restarting the SCLK input.

After all angular rate data is output, no additional angular rate data is output even if the SCLK is input with the SS logic level maintained at "L" (MISO is output at logic level "L".) To read angular rate data again, set the SS logic level to "H" (MISO is set to "High-Z") and execute the angular rate data read command (DatAccOn) again.

The angular rate data output control for both global angular rate read and normal angular rate read are indicated in Table 5.5.2.2.

Table 5.5.2.2 Angular rate data output control

Read method		A[6: 5]	Data Format	Data output order								
				1byte	2byte	3byte	4byte	5byte	6byte	7byte	8byte	9byte
Global Angular rate Read	2-axis setting	00	0	D1[15: 8]	D1[7: 0]	D2[15: 8]	D2[7: 0]	/	/	/	/	/
			1	D1[23: 16]	D1[15: 8]	D1[7: 0]	D2[23: 16]	D2[15: 8]	D2[7: 0]	/	/	/
	3-axis setting		0	D1[15: 8]	D1[7: 0]	D2[15: 8]	D2[7: 0]	D3[15: 8]	D3[7: 0]	/	/	/
			1	D1[23: 16]	D1[15: 8]	D1[7: 0]	D2[23: 16]	D2[15: 8]	D2[7: 0]	D3[23: 16]	D3[15: 8]	D3[7: 0]
Normal angular rate read		Other than 00	0	D[15: 8]	D[7: 0]	/	/	/	/	/	/	
			1	D[23: 16]	D[15: 8]	D[7: 0]	/	/	/	/	/	

(Note 1) The two types of global angular rate read, 2-axis setting and 3-axis setting, are both Epson factory settings.

(Note 2) The address A[6: 5] is the slave device address indicated in Table 5.4.1.

- (Note 3) Register name DataFormat is the angular rate data format (DataFormat=0: 16bit output/1: 24bit output) indicated in Chapter 6 (Table 6.11 Angular rate data read control)
- (Note 4) D1 is the angular rate data for the 1st axis gyro (frequency symbol H), D2 is the angular rate data for the 2nd axis gyro (frequency symbol J), and D3 is the angular rate data for the 3rd axis gyro (frequency symbol L).
- (Note 5) D is the angular rate data for the slave device (any of the 1st through 3rd axis gyro) specified with the address A[6: 5].
- (Note 6) Set the register name OutCtl[1: 0] indicated in Chapter 6 (Table 6.11 Angular rate Data Read Control) to "01" (angular rate data output).
- (Note 7) With global angular rate read, all slave devices are selected. After D1, the angular rate data for the 1st axis gyro, the angular rate data for D2 and D3 are output. Mistakenly specifying a separate angular rate data format (DataFormat=0: 16bit output/1: 24bit output) for each slave device will result in a conflict in the output angular rate data. As such, make sure the angular rate data format setting is the same for each slave device.

Ex: In the case of 1st axis gyro DataFormat=1 (24bit output) and 2nd axis gyro DataFormat=0 (16bit output), the angular rate data output in the 3rd byte will result in a conflict.

- (Note 8) Global angular rate read (address A[6: 5]="00") can be repeated in the order of 2nd, 3rd until the SS logic level is set to "H".
- (Note 9) During the global angular rate read (address A[6: 5]="00"), if there is no slave device on a certain axis, then the angular rate data for that axis is set to "High-Z". To perform the angular rate data read on an axis with no slave device, use SCLK to input the clock with the SS logic level maintained at "L" and run an empty angular rate data read for the axis you want to read.

Ex 1: Gyro on 1st axis does not exist > D1[15: 0] or D1[23: 0] is set to "High-Z".

Ex 2: Gyro on 2nd axis does not exist > D2[15: 0] or D2[23: 0] is set to "High-Z".

Ex 3: Gyro on 3rd axis does not exist > D3[15: 0] or D3[23: 0] is set to "High-Z".

5-6) Temperature sensor output read

The temperature sensor data read is conducted using the register name TempRd indicated in Chapter 6 (Table 6 User Command Register). Temperature sensor data uses the 2's compliment expression and has a data width of 8 bit, 10 bit, or 12 bit (switch using the register name TsDataFormat indicated in Table 6.15, the default value is 12 bit). Similar to the angular rate data read function, continue the serial communication until the desired bit is read. Temperature sensor data is updated in intervals of approximately 2.4 ms.

Table 5.6 Temperature sensor data output control

TsDataFormat[1]	TsDataFormat[0]	Data output order	
		1 byte	2 byte
0	0	D[7: 0]	
0	1	D[9: 2]	D[1: 0] (Note 1)
1	0	D[11: 4]	D[3: 0] (Note 2)
1	1		

(Note 1) Logic level "L" is output at LSB-side 6 bit.

(Note 2) Logic level "L" is output at LSB-side 4 bit.

5-7) Control MISO/SA0

MISO/SA0 terminal status as indicated in Table 5.7 can be changed by rewriting register name SelMISO[1: 0] indicated in Section 6-13.

Table 5.7 MISO/SA0 Terminal Control Method

Mode	SPISel	I ² C_EN	SelMISO[1]	SelMISO[0]	SS	MISO/SA0
Multi-slave	X	X	X	X	0	Output (Note 2)
	X	X	X	X	1	High-Z
4-wire SPI	0 (4-wire)	0 (I ² C Disable)	X	X	0	Output
	0	0	0	0	1	Output Level "L"
	0	0	0	1	1	Output Level "H"
	0	0	1	X	1	High-Z
3-wire SPI	1 (3-wire)	X	0	0	X	Output Level "L"
	1	X	0	1	X	Output Level "H"
	1	X	1	X	X	High-Z
I ² C	0	1 (I ² C Enable)	0	0	1	Input
	0	1	0	1	1	High-Z (Note 3)
	0	1	1	0	1	Input (pull-down)
	0	1	1	1	1	Input (pull-up)

(Note 1) The default value for SelMISO[1] is "1" and "0" for SelMISO[0].

(Note 2) The status is output during data read, High-Z during other times.

(Note 3) SA0 is fixed at "0" within the IC.

5-8) Command validation time

5-8-1) 4-wire SPI/ 3-wire SPI/ Multi-slave

Table 5.8.1 Command validation time

(VDDM=2.7~3.6V,GND=0V,Ta=-20~+80°C)

Parameter	Symbol	Standard			Unit
		Min	Typ	Max	
Sleep-in wait time	tSLPIN	10	-	-	us
Sleep-out wait time (note 1)	tSLPOUT	10	-	-	us
Standby wait time	tSTBY	10	-	-	us
Software reset wait time	tSWRST	10	-	-	us

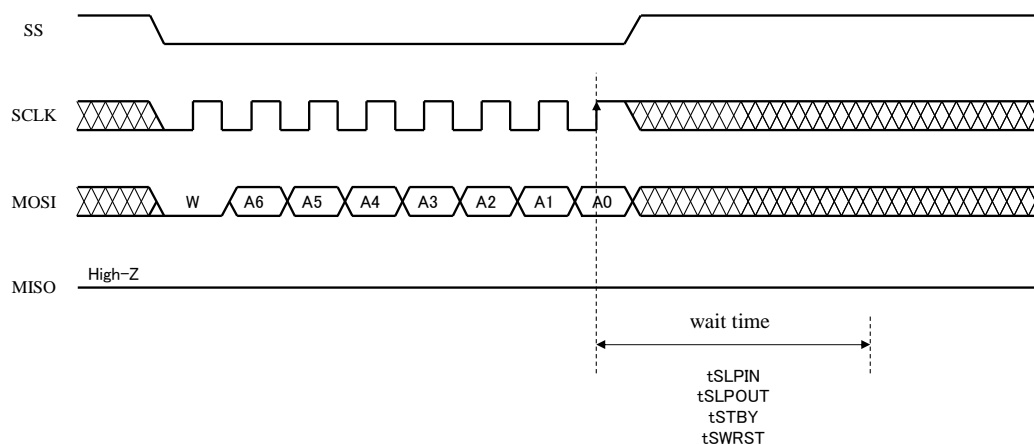

Fig. 5.8.1 Command validation time for SPI

(Note 1) Sleep-out command is validated after Sleep-in or Standby command issued and wait for tSLPOUT or tSTBY to elapse.

(Note 2) X is "1" or "0".

5-8-2) I²C

Table 5.8.2 Command validation time

(VDDM=2.7~3.6V,GND=0V,Ta=-20~+80°C)

Parameter	Symbol	Standard			Unit
		Min	Typ	Max	
Sleep-in wait time	tSLPIN	10	-	-	us
Sleep-out wait time (note 1)	tSLPOUT	10	-	-	us
Standby wait time	tSTBY	10	-	-	us
Software reset wait time	tSWRST	10	-	-	us

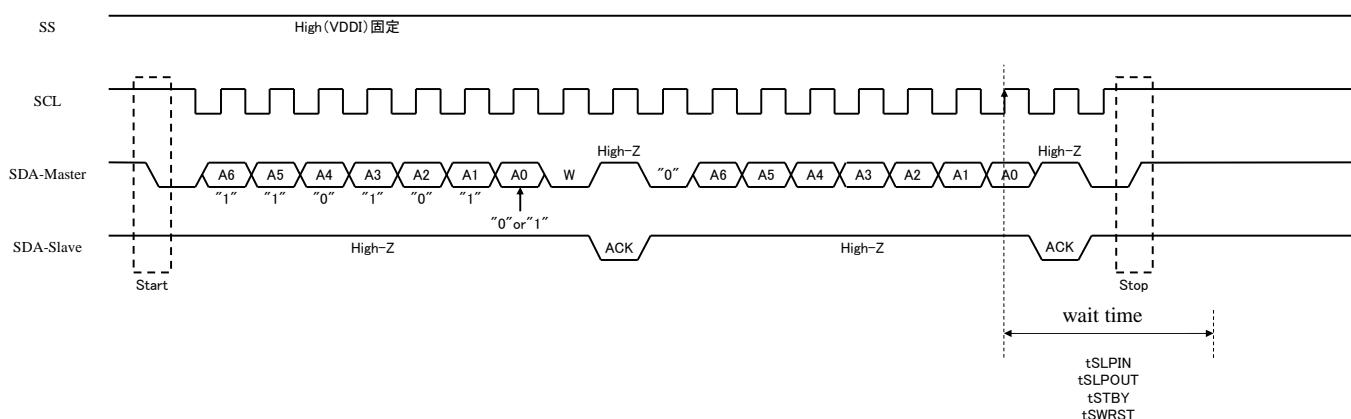

Fig. 5.8.2 Command validation time for I²C

(Note 1) Sleep-out command is validated after Sleep-in or Standby command issued and wait for tSLPOUT or tSTBY to elapse.

6) User command register

Table 6 User command register

Address	Register	R/W	Function
0x00			Reserved
0x01	DspCtl1	R/W	DSP Settings 1
0x02	DspCtl2	R/W	DSP Settings 2
0x03	DspCtl3	R/W	DSP Settings 3
0x04	StsRd	R	Status read
0x05	SlpIn	C	Sleep-in
0x06	SlpOut	C	Sleep-out
0x07	Stby	C	Standby
0x08	TempRd	R	Temperature sensor data read
0x09	SWRst	C	Software reset (user command register reset)
0x0a	DatAccOn	R	Angular rate data read
0x0b	OutCtl1	R/W	Angular rate data read control
0x0c	AutoC	C	Zero rate level calibration command (Note 1)
0x0d			Reserved
0x0e			Reserved
0x0f			Reserved
0x10			Reserved
0x11			Reserved
0x12			Reserved
0x13			Reserved
0x14			Reserved
0x15			Reserved
0x16			Reserved
0x17			Reserved
0x18			Reserved
0x19			Reserved
0x1a			Reserved
0x1b			Reserved
0x1c	TsDataFormat	R/W	Temperature sensor data format
0x1d			Reserved
0x1e			Reserved
0x1f	IFCtl	R/W	Serial interface settings

R : register read
R/W : register read and register write
C : Specify address (command)

(Note1) This command can be used only XV7011BB. Not valid for XV7001BB.

(Note2) Reserved register must not be changed. Writing to those registers may cause permanent damage to the device.

6-1) DSP Settings 1

Table 6.1 DSP Settings 1

Address	bit	Register	Default	R/W	Function	Settings
0x01	7	Reserved	0	R	Reserved	Reserved
	6	HpfFc[2]	0	R/W	HPF fc select	HpfFc[2: 0] 000: 0.01 Hz 001: 0.03 Hz 010: 0.1 Hz 011: 0.3 Hz 100: 1 Hz 101: 3 Hz 110: 10 Hz 111: Not-available
	5	HpfFc[1]	1	R/W		
	4	HpfFc[0]	0	R/W		
	3	Reserved	0	R/W	Reserved	Reserved
	2	Reserved	0	R	Reserved	Reserved
	1	EnableHpf	0	R/W	HPF Enable	0: Disable, 1: Enable
	0	Reserved	1	R/W	Reserved	Reserved

- (Note 1) Perform a reset to change settings other than to change the bit.
If the bit is within the same register (same address), then settings can be changed simultaneously.
- (Note 2) Reserved register must not be changed. Use the default settings.

6-2) DSP Settings 2

Table 6.2 DSP Settings 2

Address	bit	Register	Default	R/W	Function	Settings
0x02	7	Reserved	0	R	Reserved	Reserved
	6	Reserved	0	R/W	Reserved	Reserved
	5	LpfOrder[1]	0	R/W	LPForder select	LpfOrder[1: 0] 00: 2nd order 01: 3rd order 10: 4th order 11: Not Available
	4	LpfOrder[0]	0	R/W		
	3	LpfFc[3]	0	R/W	LPF fc select	LpfFc[3: 0] 0000: 10Hz 0001: 35Hz 0010: 45Hz 0011: 50Hz 0100: 70Hz 0101: 85Hz 0110: 100Hz 0111: 140Hz 1000: 175Hz 1001: 200Hz 1010: 285Hz 1011: 345Hz 1100: 400Hz 1101: 500Hz 1110: Not Available 1111: Not Available
	2	LpfFc[2]	1	R/W		
	1	LpfFc[1]	1	R/W		
	0	LpfFc[0]	0	R/W		

(Note 1) Perform a reset to change settings other than to change the bit.

If the bit is within the same register (same address), then settings can be changed simultaneously.

(Note 2) Reserved register must not be changed. Use the default settings.

6-3) DSP Settings 3

Table 6.3 DSP Settings 3

Address	bit	Register	Default	R/W	Function	Settings
0x03	7	Reserved	0	R	Reserved	Reserved
	6	EnCalibCmd	0	R/W	Zero rate level calibration	0: Disable, 1: Enable (Note 2)
	5	Reserved	0	R/W	Reserved	Reserved
	4	Reserved	0	R	Reserved	Reserved
	3	Reserved	0	R	Reserved	Reserved
	2	SelFs[2]	0	R/W	Select angular rate output sampling rate fds	SelFs[2: 0] (Note 3) 000: fs 001: fs/2 010: fs/4 011: fs/8 100: fs/16 101: fs/32 110: fs/64 111: fs/128
	1	SelFs[1]	0	R/W		
0	SelFs[0]	0	R/W			

(Note 1) Perform a reset to change settings other than to change the bit.

If the bit is within the same register (same address), then settings can be changed simultaneously.

(Note 2) To carry out zero rate level calibration in Section 6-12, setting should be Enable.

This function can be used only XV7011BB. Not valid for XV7001BB.

(Note 3) fs is the AD converter sample rate. It carries out down sampling of the angular rate output.

(Note 4) Reserved register must not be changed. Use the default settings.

6-4) Status read

Table 6.4 Status Read

Address	bit	Register	Default	R/W	Function	Settings
0x04	7	Reserved		R	Reserved	Reserved
	6	Reserved		R	Reserved	Reserved
	5	Reserved		R	Reserved	Reserved
	4	Reserved		R	Reserved	Reserved
	3	ProcOK		R	Temperature sensor data output flag	0: Data output not available 1: Data output available
	2	preStsPOR		R	Status flag	Bit[2: 0] (Note 1) 100: After turning power ON 010: Stand-by 000: Sleep 001: Sleep out
	1	preStsStby		R		
	0	preStsSlpOut		R		

(Note 1) Only indicated combinations allowed.

6-5) Sleep-in

Specify address as "0x05". No data read or write.

During sleep, only register access is possible.

Status for angular rate data and temperature sensor data is "0".

Conduct the sleep-out command in Section 6-6 to disable sleep mode.

6-6) Sleep-out

Specify address as "0x06". No data read or write.

Returns to normal operations from sleep mode or standby mode.

This resets the DSP.

6-7) Standby

Specify address as "0x07". No data read or write.

During standby, the detection circuit is set to disable.

Status for angular rate data and temperature sensor data is "0".

Conduct the sleep-out command in Section 6-6 to disable standby mode.

However, you cannot transition from sleep mode to standby mode.

6-8) Temperature sensor data read

Specify address as "0x08". Only data read (no data write).

Refer to Section 5-6(Temperature Sensor Data Read) regarding the temperature sensor data read function.

6-9) Software reset

Specify address as "0x09". No data read or write.

The user command register indicated in Table 6 is reset (set to the default value).

6-10) Angular rate data read

Specify address as "0x0a". Only data read (no data write).

Refer to Section 5-5(Angular rate Data Read) regarding the angular rate data read function.

6-11) Angular rate data read control

Table 6.11 Angular rate data read control

Address	bit	Register	Default	R/W	Function	Settings
0x0b	7	Reserved	0	R	Reserved	Reserved
	6	Reserved	0	R	Reserved	Reserved
	5	Reserved	0	R/W	Reserved	Reserved
	4	Reserved	0	R/W	Reserved	Reserved
	3	Reserved	0	R/W	Reserved	Reserved
	2	DataFormat	0	R/W	Angular rate data format	0: 16bit output 1: 24bit output
	1	Reserved	0	R/W	Reserved	Reserved
	0	Reserved	1	R/W	Reserved	Reserved

(Note 1) Perform a reset to change settings other than to change the bit.

If the bit is within the same register (same address), then settings can be changed simultaneously.

(Note 2) Reserved register must not be changed. Use the default settings.

6-12) Zero rate level calibration command

Specify address as "0x0c". No data read or write.

Zero rate level calibration is carried out at the moment command conducted.

To issue this command, enable register name EnCalibCmd indicated in Table 6.3.

To disable the calibration value, disable register name EnCalibCmd indicated in Table 6.3.

This command can be used only XV7011BB. Not valid for XV7001BB.

6-13) Temperature sensor data format

Table 6.13 Temperature sensor data format

Address	bit	Register	Default	R/W	Function	Settings
0x1c	7	Reserved	0	R	Reserved	Reserved
	6	TsDataFormat[1]	1	R/W	Temperature sensor data format	TsDataFormat[1: 0] 00: 8 bit output 01: 10 bit output 10: 12 bit output 11: Not Available
	5	TsDataFormat[0]	0	R/W		
	4	Reserved	0	R/W	Reserved	Reserved
	3	SelMISO[1]	1	R/W	MISO/SA0 terminal status selection	(Note 3)
	2	SelMISO[0]	0	R/W		
	1	Reserved	1	R/W	Reserved	Reserved
	0	Reserved	1	R/W	Reserved	Reserved

- (Note 1) Perform a reset to change settings other than to change the bit.
If the bit is within the same register (same address), then settings can be changed simultaneously.
- (Note 2) Reserved register must not be changed. Use the default settings.
- (Note 3) Refer to Section 5-7(MISO/SA0 Terminal Control Methods) indicated in Chapter 5 for details on settings.

6-14) Serial interface settings

Table 6.14 Serial interface settings

Address	bit	Register	Default	R/W	Function	Settings
0x1f	7	Reserved	0	R	Reserved	Reserved
	6	Reserved	0	R	Reserved	Reserved
	5	Reserved	0	R	Reserved	Reserved
	4	Reserved	0	R	Reserved	Reserved
	3	Reserved	0	R	Reserved	Reserved
	2	Reserved	0	R	Reserved	Reserved
	1	SPISel (Note 3)	0	R/W	4-wire/3-wire SPI select	0: 4-wire SPI, 1: 3-wire SPI
	0	I ² C_EN (Note 3)	1	R/W	I ² C enable	0: Disable , 1: Enable

- (Note 1) Perform a reset to change settings other than to change the bit.
If the bit is within the same register (same address), then settings can be changed simultaneously.
- (Note 2) The mode indicated in Table 6.16 can be changed only when using SPI communication.
- (Note 3) Register settings are not set when the multi-slave function is enabled via factory settings.
- (Note 4) Reserved register must not be changed. Use the default settings.

7) Connection diagram

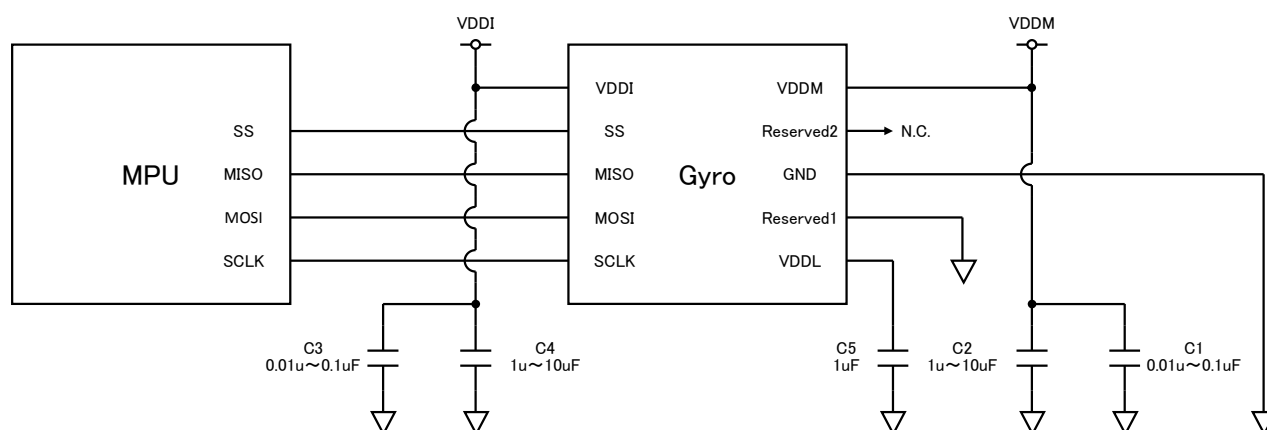

Fig. 7.1 Example of 4-wire SPI connection

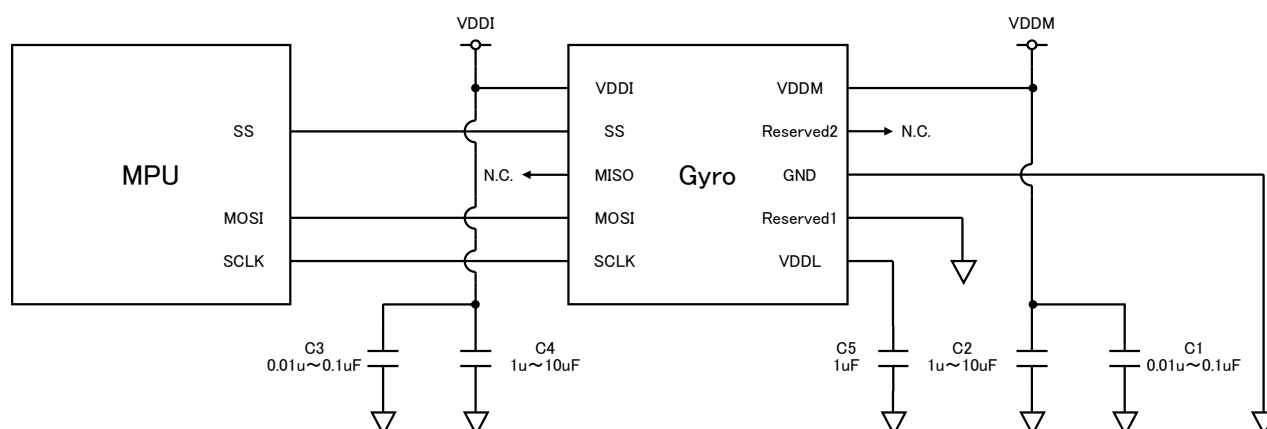

Fig. 7.2 Example of 3-wire SPI connection

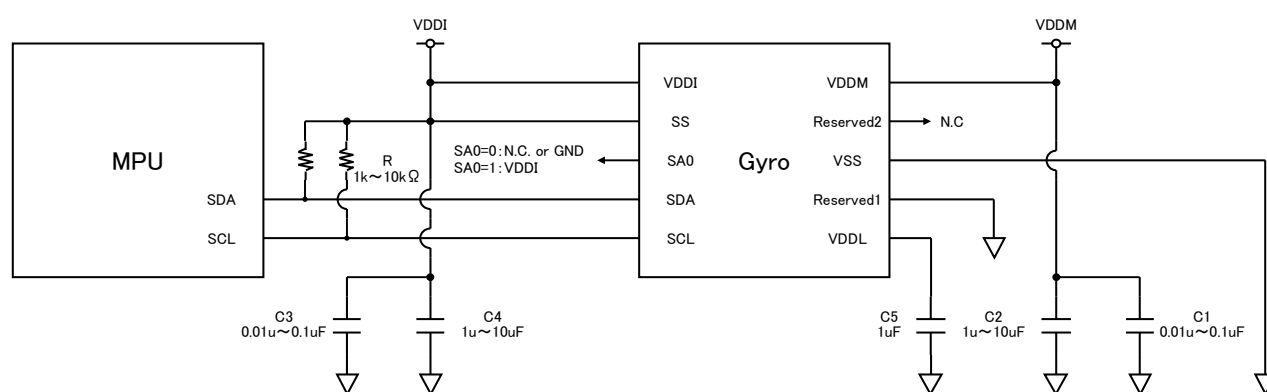

Fig. 7.3 Example of I²C connection

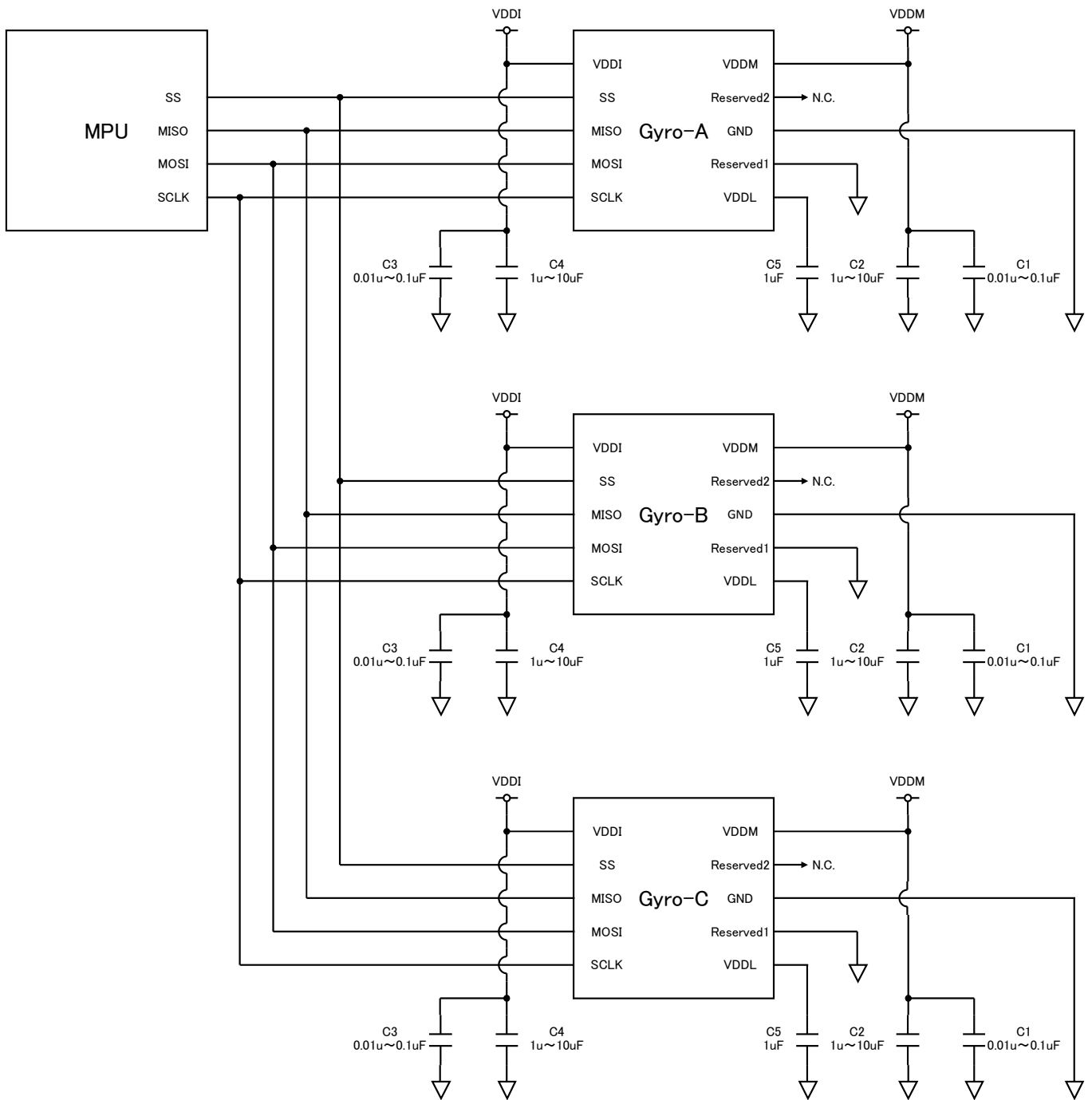
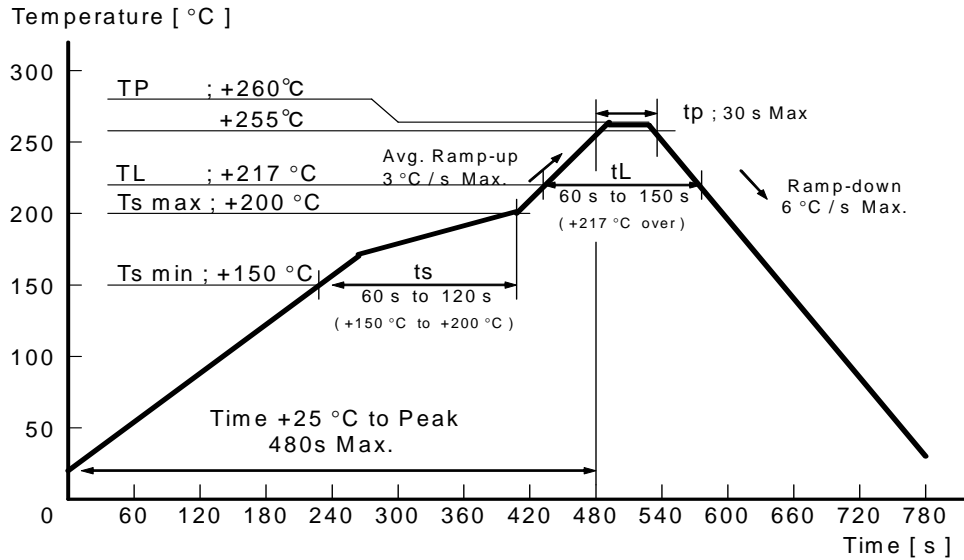

Fig. 7.4 Example of Multi-slave connection

8) Soldering profile

Solder heat resistance verified under the air reflow furnace conditions below.



9) Terminology

9-1) Cross axis sensitivity

The value is derived by dividing sensitivity around the X and Y axis by the sensitivity around the Z axis. The X, Y, and Z axis directions are as shown in the following diagram.

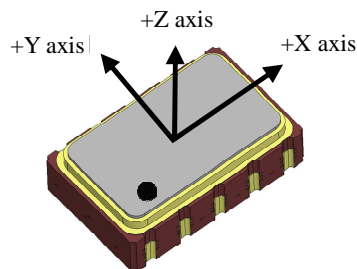

#1 Terminal mark

9-2) Drive frequency and detuning frequency

The drive frequency is the resonance frequency (drive mode) of the sensor element continuously vibrated to gain the Coriolis force. The detuning frequency is the natural frequency used for the mechanical-electrical transduction of the Coriolis force. It is the difference from the drive frequency.

10) Handling precaution

Crystal devices are high precision products. Use the following precautions during handling.

1. The detuning frequency for this product is 900 Hz \pm 200 Hz. During board design, the customer must ensure that the board resonance frequency is not within the vicinity of this detuning frequency. When mounting on a board, align the sensor near a board loading component with low resonance variation.
2. Excessive shock from adsorption / chucking when mounting the sensor or excessive vibration or shock during board cutting or an impact wrench after mounting can result in damage to the sensor or the deterioration of sensor properties. Establish conditions that avoid vibration or shock to the sensor to ensure there is not loss in performance.
3. To detect angular rate, this product uses a drive frequency to drive the sensor element. External application of a signal with frequency components in the vicinity of the drive frequency or high-order harmonics can result in fluctuations in angular rate output by the sensor. Be sure to confirm internally in advance concerning power supply decoupling measures and serial interface communications frequency settings.
4. To prevent malfunctions caused by electromagnetic induction and static induction from other signal lines, during pattern design do not pass other signal lines near the sensor or along the back of the package. Also, use a pattern design that does not cross with other signal lines.
5. It may occur communication error with the device due to the signal pattern of board. In that case, please connect dumping resistor to reduce noise / overshoot / undershoot of the signal.
6. Confirm internally in advance concerning measures for vibration, shock, and noise. We will provide design support if you provide us with board design information.
6. This product design incorporates shock resistance but there is the risk of product damage due to drops and shock. **Do not use this product if it has been dropped as we cannot guarantee product performance.**
7. Applying ultrasonic vibration during ultrasonic washing can cause resonance damage to the crystal unit depending on usage conditions. As we cannot specify the usage conditions (washer type, power, time, tub position, etc.) at your company, we offer no guarantees concerning operability after the application of ultrasonic vibration. Confirm internally prior to use if the use of ultrasonic washing is required.
8. Prior to use, conduct mounting tests internally to confirm there is no impact on performance. Similarly, confirm prior to changing any conditions. During and after mounting, ensure that the sensor is not in contact with boards or structural elements.
9. The sensor includes a static electricity protection circuit but application of significant static electricity can result in damage to the sensor's internal IC. Make sure to use conductive materials for packaging and transport containers as well. For the soldering iron, measurement circuit, etc., use products with no high-voltage leaks and during mounting make sure to employ static electricity measures such as the use of a ground wire.
10. Keep reflow to no more than three times. Use a soldering iron to correct any soldering mistakes. Here, the temperature of the iron type should be below +350 °C and less than 3 seconds. (Blower use not allowed)
11. We recommend using board production based on Epson pad dimensions.
12. This product has the same frequency noise as drive frequency. Remove using an appropriate filter circuits.
13. This product is designed to resist acoustic interference even when multiple sensors are operated in close proximity but impedance common to board resonance and power supply could result in mechanical or electrical interference. Confirm internally prior to use.
14. This product includes a POR circuit. To avoid POR circuit malfunctions, power supply voltage rise should be conducted between 0.01 ms and 100 ms.
15. Do not use in high condensation or other environments prone to short circuits between terminals.

11) Contact

America

Epson Electronics America, Inc.
214 Devcon Drive, San Jose, CA 95112, USA
Phone: +1-800-228-3964 FAX: +1-408-922-0238

Europe

Epson Europe Electronics GmbH
Riesstrasse 15, 80992 Munich, GERMANY
Phone: +49-89-14005-0 FAX: +49-89-14005-110

ASIA

Epson (China) Co., Ltd.
7F, Jinbao Bldg., No.89 Jinbao Street Dongcheng District, Beijing, China, 100005
Phone: +86-10-8522-1199 FAX: +86-10-8522-1120

Shanghai Branch

High-Tech Building, 900 Yishan Road, Shanghai 200233, China
Phone: +86-21-5423-5577 FAX: +86-21-5423-4677

Shenzhen Branch

12/F, Dawning Mansion, #12 Keji South Road, Hi-Tech Park, Shenzhen, China
Phone: +86-755-2699-3828 FAX: +86-755-2699-3838

Epson Hong Kong Ltd.

Unit 715-723 7/F, Trade Square, 681 Cheung Sha Wan Road, Kowloon, Hong Kong
Phone: (86) 755-26993828 (Shenzhen Branch)
FAX: (86) 755-26993838 (Shenzhen Branch)

Epson Taiwan Technology & Trading Ltd.

14F, No. 7, Song Ren Road, Taipei 110, TAIWAN
Phone: +886-2-8786-6688 FAX: +886-2-8786-6660

Epson Singapore Pte., Ltd.

No 1 HarbourFront Place, #03-02 HarbourFront Tower One, Singapore 098633
Phone: +65-6586-5500 FAX: +65-6271-3182

Seiko Epson Corp. Korea Office

5F (63Bldg., Yoido-dong) 50, 63-ro, Yeongdeungpo-gu, Seoul, 150-763, Korea
Phone: +82-2-784-6027 FAX: +82-2-767-3677

X-ON Electronics

Largest Supplier of Electrical and Electronic Components

Click to view similar products for [Board Mount Hall Effect/Magnetic Sensors](#) category:

Click to view products by [Epson](#) manufacturer:

Other Similar products are found below :

[HGPRDT005A](#) [AH277AZ4-AG1](#) [AV-10448](#) [HMC1041Z-TR](#) [SS41C](#) [TLE4917](#) [TLE4946-1L](#) [50017859-003](#) [TY-13101](#) [TLE4976L](#)
[SS85CA](#) [BU52002GUL-E2](#) [BU52003GUL-E2](#) [AH277AZ4-BG1](#) [TLE49614MXTSA1](#) [AH3376-P-B](#) [TLE4941](#) [AH211Z4-AG1](#) [AH3360-](#)
[FT4-7](#) [TLE4941-1](#) [AH374-P-A](#) [SS460P-T2](#) [AH1913-W-7](#) [AH3373-P-B](#) [TLE9852QXXUMA1](#) [MA732GQ-Z](#) [MA330GQ-Z](#) [S-57K1NBL2A-](#)
[M3T2U](#) [S-57P1NBL9S-M3T4U](#) [S-576ZNL2B-L3T2U](#) [S-576ZNL2B-A6T8U](#) [S-57P1NBL0S-M3T4U](#) [S-57A1NSL1A-M3T2U](#) [S-](#)
[57K1RBL1A-M3T2U](#) [S-57P1NBH9S-M3T4U](#) [S-57P1NBH0S-M3T4U](#) [S-57A1NSH1A-M3T2U](#) [S-57A1NSH2A-M3T2U](#) [S-57K1NBH1A-](#)
[M3T2U](#) [S-57A1NNL1A-M3T2U](#) [S-5701BC10B-L3T2U5](#) [S-5701BC11B-L3T2U5](#) [S-57GNNL3S-A6T8U](#) [S-57TZ1L1S-A6T8U](#) [S-](#)
[57GSNL3S-A6T8U](#) [S-5716ANDH0-I4T1U](#) [S-57GSNL5S-L3T2U](#) [S-57GDNL3S-L3T2U](#) [S-57GNNL3S-L3T2U](#) [S-57RBNL8S-L3T2U](#)