

REV.		MODIFICATION.	DATE	DRN
01		Production release	16/03/10	MT

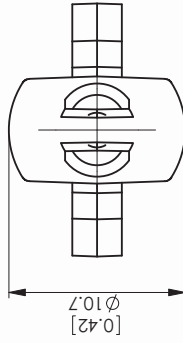

TO SNAP LOCK INTO A $\phi 4.8$ [.189] HOLE
IN A 1.6mm [.063] PANEL THICKNESS

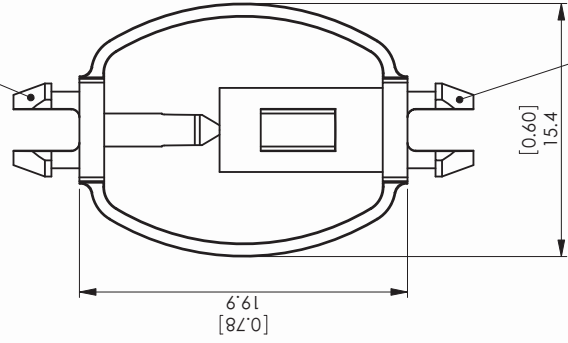

FIG 1

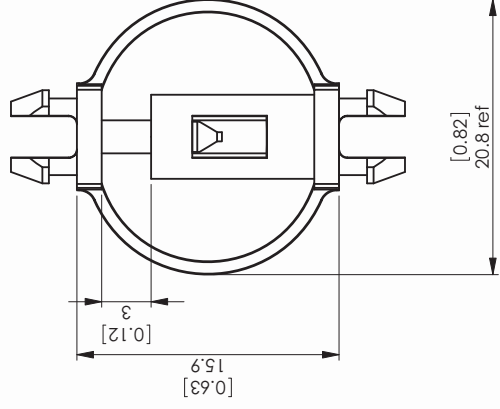

FIG 2

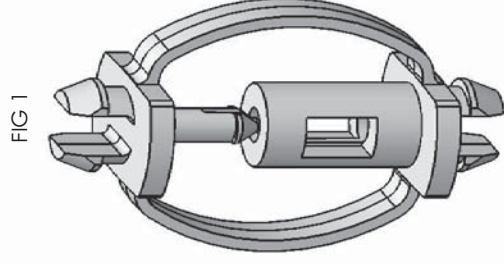

FIG 1

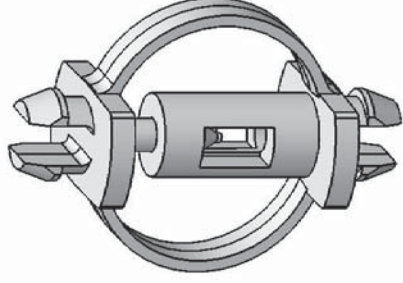

FIG 2

NOTE: PARTS ARE SUPPLIED AS PER FIG 1

INFORMATION CONTAINED IN THIS DOCUMENT IS CONFIDENTIAL TO RICHCO INTERNATIONAL CO. LTD. AND MAY NOT BE DISCLOSED OR REPRODUCED IN WHOLE OR PART WITHOUT THEIR WRITTEN CONSENT.

RICHCO, INC.
WWW.RICHCO-INC.COM

METRIC PRIMARY UNITS (MM)
IMPERIAL SECONDARY UNITS (INCHES)
GENERAL TOLERANCES ± 0.25 [0.010]
UNLESS OTHERWISE STATED
2 DECIMAL PLACES \pm
ANGULAR $\pm 1^\circ$



MATERIAL:	ACETAL (RMS-061)	COLOUR:	NATURAL
DESCRIPTION:	SPRUNG SPACER	PART NO:	CBSP-1
DRG No:	010-019	NPR No:	GB08-0052
DRN	MT	DATE	19/09/08
CHKD	MT	DATE	16/03/10
SCALE	NTS	SHEET No.	1 OF 1
		FORM No.	0145/02

X-ON Electronics

Largest Supplier of Electrical and Electronic Components

Click to view similar products for [Standoffs & Spacers](#) category:

Click to view products by [ESSENTRA](#) manufacturer:

Other Similar products are found below :

[588-6208-02](#) [599-9844-02](#) [M0516-3-N](#) [M0518-3-N](#) [M0521-3-N](#) [M0524-3-N](#) [M0532-35-N](#) [M0543-4-AL](#) [M0544-35-N](#) [M0544-3-N](#) [M0545-3-AL](#) [M0553-3-N](#) [M0608-5-SS](#) [M0609-5-SS](#) [M0651-5-SS](#) [M0653-35-N](#) [M0654-4-SS](#) [M0655-5-AL](#) [M0658-35-AL](#) [M0660-4-AL](#) [M0660-4-N](#) [M0670-35-N](#) [M0671-5-N](#) [M0671-5-SS](#) [M0722-5-N](#) [M0725-6-N](#) [M0904-B-25-AL](#) [M1273-2545-AL](#) [M1273-2545-SS](#) [M1273-3005-AL](#) [M1273-3005-SS](#) [M1274-3005-AL](#) [60187](#) [60202-SP](#) [60273](#) [60335-SP](#) [60348-SP](#) [60419-SP](#) [60425-SP](#) [60473-SP](#) [60475-SP](#) [60477-SP](#) [60489-SP](#) [60491-SP](#) [60585-SP](#) [60762-SP](#) [60763-SP](#) [60872-SP](#) [M1303-3506-AL](#) [M1307-3506-AL](#)