

0.03 Typ. 45 ribs
eq. spaced @ 8°

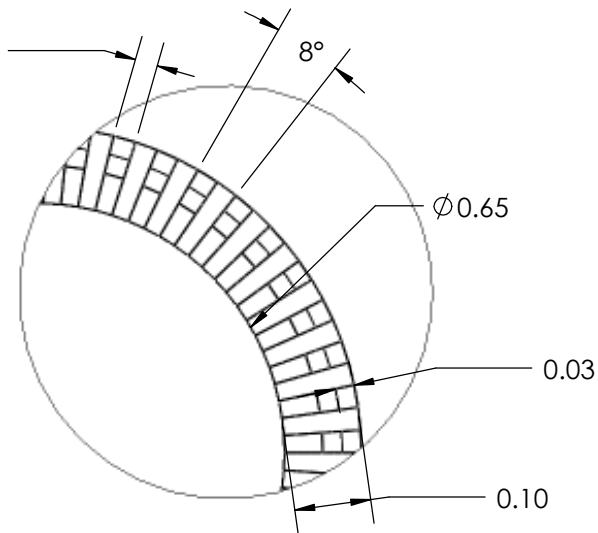

DETAIL A
SCALE 4 : 1

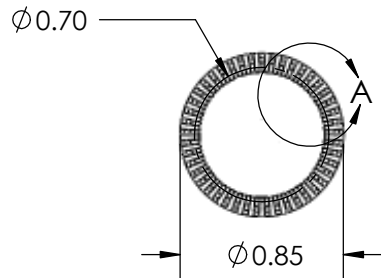

Note: Threaded parts must accept 2A GO gage. Per current fastener industry practice, if form, fit, and function are achieved, parts may accept 2A NO GO.

REV	BY	DATE	COMMENT	DIMENSIONS ARE IN INCHES TOLERANCES FRACTIONAL ± TWO PLACE DECIMAL ± 0.03 THREE PLACE DECIMAL ± 0.010 UNLESS OTHERWISE NOTED	DRAWN VRR	INNOVATIVE COMPONENTS	
0	JMR	07/25/08	RELEASE DATE		APPROVED LQR	PART NAME	
1	VRR	03/07/14	Added thread specs		DATE 03/07/2014	0.75" Round Knurled Knob 10-24 x 5/8" Steel, Zinc Stud, Nylon	
				KNOB MATERIAL Nylon, Black	COMMENTS	PART NUMBER KN040625K3--N21	DRAWING NUMBER 11-5-13 R1
PROPRIETARY AND CONFIDENTIAL THE INFORMATION CONTAINED IN THIS DRAWING IS THE SOLE PROPERTY OF INNOVATIVE COMPONENTS. ANY REPRODUCTION IN PART OR AS A WHOLE WITHOUT THE WRITTEN PERMISSION OF INNOVATIVE COMPONENTS IS PROHIBITED.				KNOB FINISH Textured	INSERT MATERIAL Steel	SCALE 1:1	SHEET 1 OF 2
				INSERT PART NUMBER MS040875RS--21	INSERT FINISH Zinc		

X-ON Electronics

Largest Supplier of Electrical and Electronic Components

Click to view similar products for [Knobs & Dials](#) category:

Click to view products by [ESSENTRA](#) manufacturer:

Other Similar products are found below :

[790-1030](#) [790-1202](#) [790-2226](#) [8519](#) [8529](#) [8547](#) [85-559](#) [8573](#) [11K5015-EMNB](#) [11K5019-ECNB](#) [11K5020-KLAB](#) [11K5048-KMNB](#)
[11K5014-EMNB](#) [11K5015-EMNG](#) [11K5019-EMNB](#) [MS91528-2N2B](#) [1770](#) [P400S-08-D6-N](#) [K6510](#) [KNP700A1/4](#) [3045B](#) [AR22PY-122B](#)
[PKJ50B18](#) [277A](#) [348003](#) [42000B38](#) [420114B14](#) [5006](#) [56008-001](#) [KS700B14](#) [411](#) [420037B14](#) [WA-101C-P](#) [WA-102B](#) [WA-103](#) [WA-109B](#)
[WA-1450-P](#) [WA-1550](#) [WA-1600-P](#) [WA-2300](#) [WA-4100](#) [WA-4108-P](#) [0166736-006](#) [0195316-052](#) [0703006-003](#) [0744386-211](#) [52-928.20](#)
[52-928.9](#) [8517](#) [8545](#)