

**Analog Reinvented**

The SABRE® ES9081 High Performance Audio DAC is an 8-channel audio digital to analog converter (DAC) incorporating an integrated line driver that targets consumer and professional applications with integrated components to reduce system Bill-Of-Material (BOM) costs.

Using ESS' patented HyperStream® IV architecture and advanced SABRE HiFi® technology, the ES9081 delivers a True DNR +120dB DNR and -108dB THD+N per channel and provides the listener with the legendary SABRE® sound quality with improved audio performance and a refined and enjoyable listening experience.

The ES9081 incorporates:

- Digital Volume range from +1 to -126dB in 0.5dB steps with 0 to +42dB pre-gain in +6dB Steps
- 8 internal digital filters
- The integrated proprietary Analog PLL eliminates an external oscillator with no effect on performance.

With the integrated line drivers, the ES9081 reduces BOM costs by eliminating the need for external amplifiers to produce a line level $2V_{rms}$ output on each of the 8 channels. Channels can be summed to improve performance in an application requiring fewer channels. A 2-channel differential configuration can achieve up to +127dB DNR with a $4V_{RMS}$ output. A 4-channel sum configuration can achieve +123dB DNR with $2V_{rms}$ single-ended output.

The SABRE® DAC flexible input architecture accepts serial data up to a 768kHz sample rate (64FS mode) & DSD1024.

The ES9081 is drop-in compatible with the previous generation of ES9080 and allows customers to upgrade seamlessly and achieve higher performance with their current systems.

The ES9081 sets a new standard for high-quality audio performance in a cost-effective, compact, easy to use form factor for today's most demanding digital audio applications.

FEATURE	DESCRIPTION
+120dB DNR per channel -108dB THD+N per channel	Ultra-low noise and distortion
High Sample Rates	Support for sample rates up to and including 768kHz & DSD1024
8-channel DAC + $2V_{rms}$ Line Driver	The ground centered line driver reduces BOM costs w/o required external amplifier. Reduced footprint and simplifies board layout
Versatile Digital Audio Input Port	Supports Serial Data Interface inputs such as TDM, I ² S, LJ, DoP, and DSD formats.
S/PDIF Encoder	An S/PDIF encoder is integrated for format conversion
I ² C Control Interface	Standard I ² C interface for programming desired settings
Integrated Low Noise DAC Reference Regulators	Reduced BOM cost, PCB area and improved DNR
Customizable Filter Selection	8 preset digital filters
Low Pin Count Standardized Packages	5mm x 5mm, 40 pin QFN, drop-in compatible with ES9080* (See pinout)

APPLICATIONS

- Soundbar Applications
- Multi-Channel Live Stream Media
- Class-D Pre-Amplifier Controller & Integrated Amplifiers
- AVR Receivers & Gaming Motherboards

Table of Contents

Table of Contents	2
List of Figures	5
List of Tables	6
Functional Block Diagram	7
ES9081 Package	8
40 QFN Pinout	8
40 QFN Pin Descriptions	9
Digital Features	11
I ² C Slave Interface	11
I ² C Slave Interface Commands	11
Audio Input/Output Formats	12
PCM/TDM Decoder	13
PCM (I ² S, LJ) Format	14
TDM Format	15
DSD Format	16
PDM Decoder	17
PDM Format	17
S/PDIF Encoder	17
Digital Signal Path	18
Volume Control	18
Gain	19
Automute	20
8x FIR Filter	20
IIR Filter	20
Soft Ramp & DC Offset	20
GPIO Configuration	21
Analog Outputs Off	21
Output 1'b0	21
Output 1'b1	21
Clock Valid	21
PLL Locked Flag	21
DAC Minimum Volume Flag	22
DAC Automute Status	22



ES9081 Product Datasheet

DAC Soft Ramp Done Flag	22
Mute DAC	22
System Mode Control	22
OR of Status Bits	22
S/PDIF Stream.....	22
PWM Signal	23
MCLK_128FS	23
Pre-Programmed Digital Filters	24
PCM Filter Latency	25
PCM Filter Properties.....	26
PCM Filter Frequency Response	28
PCM Filter Impulse Response	32
64FS Mode	36
Analog Features	38
APLL	38
Absolute Maximum Ratings	40
ESD Ratings	40
IO Electrical Characteristics.....	40
Switching Characteristics.....	41
Timing Characteristics	42
Bit-Clock (BCLK) and Word-Select (WS) Timing.....	42
I ² C Slave Interface Timing.....	43
Recommended Operating Conditions.....	44
Charge Pump	44
Recommended Power Up/Down Sequence	45
Power Consumption	46
Performance.....	47
Register Overview	48
Read/Write Register Addresses	48
Read-Only Register Addresses	48
Multi-Byte Registers	48
Register Map	49
Register Listing	52
System Registers	52



ES9081 Product Datasheet

GPIO Registers	73
DAC Registers.....	81
PLL Registers.....	92
Readback Registers	94
ES9081 Reference Schematic.....	99
Recommended Power Supply	100
Internal Pad Circuitry	101
40 QFN Package Dimensions	103
40 QFN Top View Marking	104
Reflow Process Considerations	105
Temperature Controlled	105
Manual	106
RPC-1 Classification Reflow Profile	106
RPC-2 Pb-Free Process - Classification Temperatures (Tc).....	107
Ordering Information.....	108
Revision History.....	108

ES9081 Product Datasheet

List of Figures

Figure 1 - ES9081 Block Diagram	7
Figure 2 - ES9081 40QFN Pinout.....	8
Figure 3 - I ² C Write Example	11
Figure 4 - I ² C Read Example	11
Figure 5 - LJ (top) & I ² S (bottom) for 16,24, and 32-bit Word Widths.....	14
Figure 6 - TDM4 Mode.....	15
Figure 7 - TDM8 Mode.....	15
Figure 8 - TDM16 Mode.....	15
Figure 9 - DSD Format, 1-bit stream.....	16
Figure 10 - PDM 8 Channel Format.....	17
Figure 11 - Digital Signal Path	18
Figure 12 - ES9081 Volume Range	19
Figure 13 - Minimum Phase 64FS Frequency Response	37
Figure 14 - Minimum Phase 64FS Impulse Response.....	37
Figure 15 - Functional Block Diagram of ES9081 APLL	38
Figure 16 - Bit-Clock and Word-Select Timing.....	42
Figure 17 - I ² C Slave Control Interface Timing.....	43
Figure 18 – Recommended Power Up Sequence.....	45
Figure 19 – Recommended Power Down Sequence	45
Figure 20 - ES9081 SW Mode Schematic	99
Figure 21 - ES9081 Power Supply Schematic.....	100
Figure 22 - ES9081 40 QFN Package Dimensions.....	103
Figure 23 - ES9081 48 QFN Top View Markings.....	104
Figure 24 - IR/Convection Reflow Profile (IPC/JEDEC J-STD-020D.1)	105

List of Tables

Table 1 - 40QFN Pin Descriptions	10
Table 2 - PCM Pin Connections.....	14
Table 3 - TDM Pin Connections.....	15
Table 4 - DSD Pin Connections.....	16
Table 5 - PDM Pin Connections.....	17
Table 6 - GPIO Configuration	21
Table 7 - Pre-Programmed Digital Filter Descriptions.....	24
Table 8 - PCM Filter Latency	25
Table 9 - PCM Filter Properties	27
Table 10 - PCM Filter Frequency Response.....	31
Table 11 - PCM Filter Impulse Response	35
Table 12 - Minimum Phase 64FS Latency.....	36
Table 13 - Minimum Phase 64FS Properties	36
Table 14 - APLL Divider Values for 44.1kHz Base Rates	39
Table 15 - APLL Divider Values for 48kHz Base Rates	39
Table 16 - Absolute Maximum Ratings.....	40
Table 17 - ESD Ratings.....	40
Table 18 - I/O Electrical Characteristics.....	40
Table 19 - Switching Characteristics.....	41
Table 20 - Bit-Clock and Word-Select Timing Definitions	42
Table 21 - I ² C Slave/Synchronous Slave Interface Timing Definitions.....	43
Table 22 - Recommended Operating Conditions.....	44
Table 23 - Power Consumption	46
Table 24 - Performance	47
Table 25 – Internal Pad Circuitry	102
Table 26 - RPC-1 Classification Reflow Profile.....	106
Table 27 - RPC-2 Pb Free Classification Temperatures.....	107
Table 28 - Ordering Information.....	108

ES9081 Product Datasheet

Functional Block Diagram

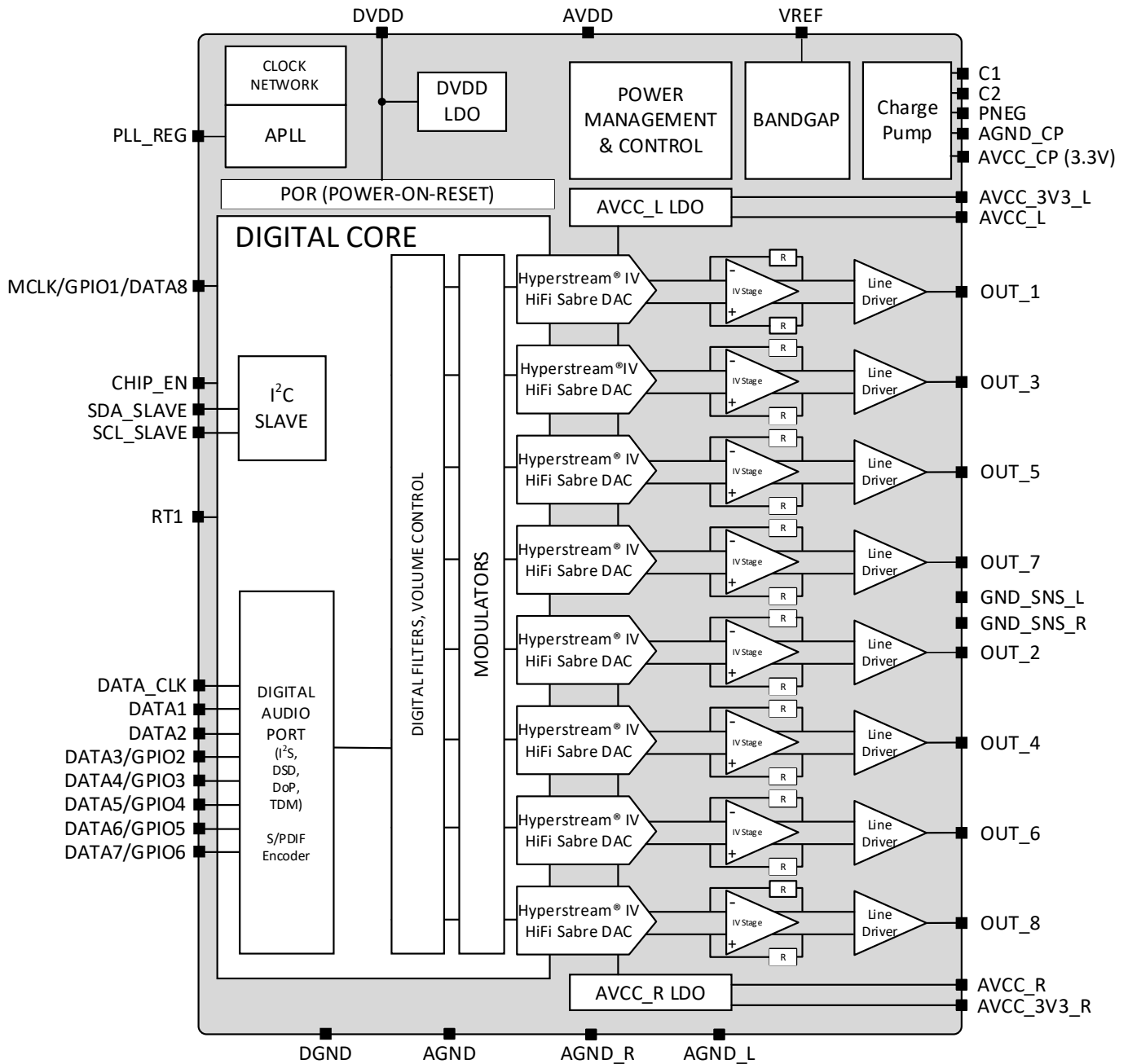
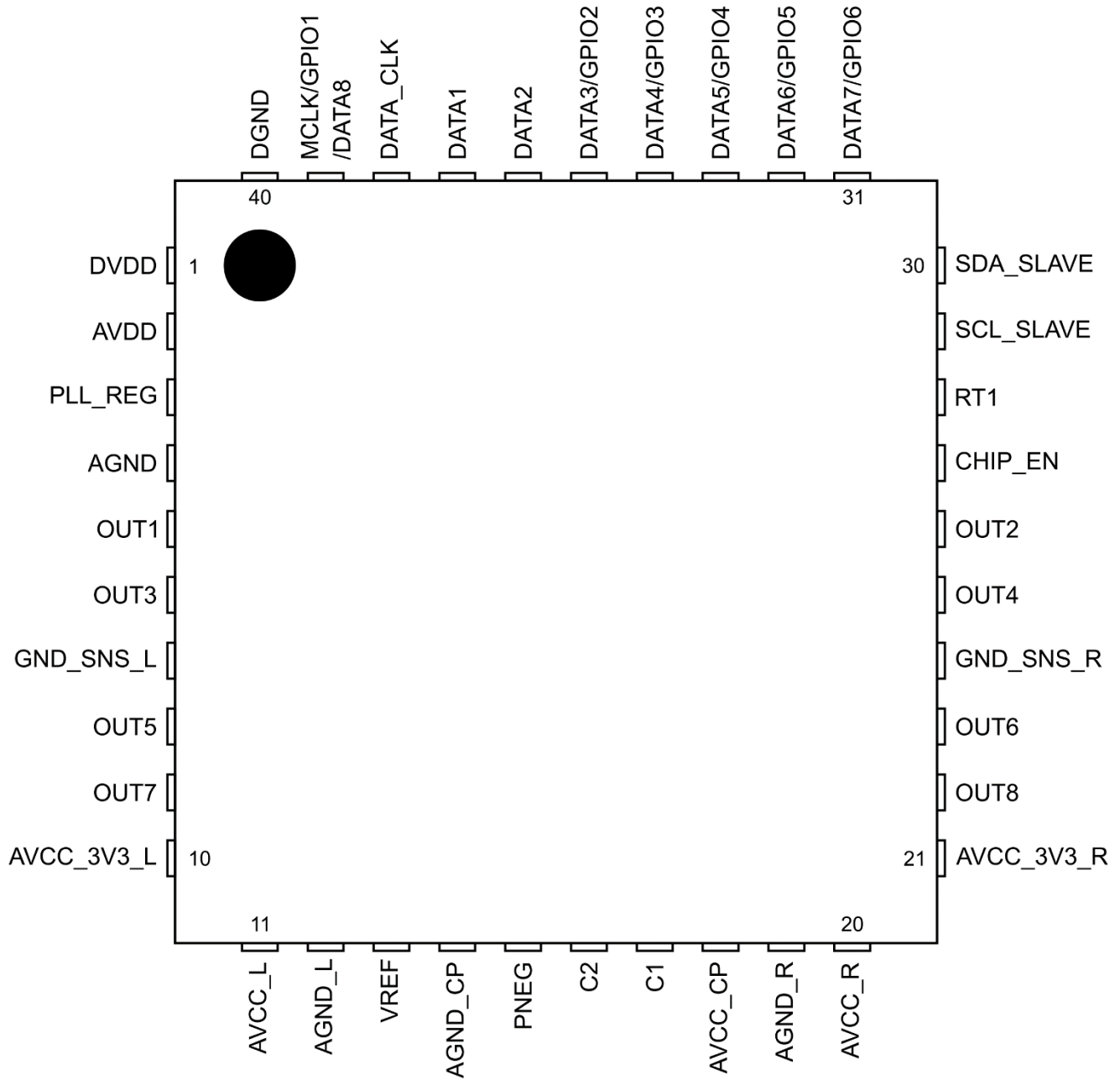

Figure 1 - ES9081 Block Diagram

ES9081 Package

40 QFN Pinout



ES9081Q
(Top View)

Figure 2 - ES9081 40QFN Pinout

ES9081 Product Datasheet

40 QFN Pin Descriptions

Pin	Name	Pin Type	Reset State	Pin Description
1	DVDD	A O	P/D	Digital core supply, internally supplied
2	AVDD	Power	Power	3.3V or 1.8V I/O supply
3	PLL_REG ¹	A O	Ground	PLL Voltage Reference, Capacitor to ground
4	AGND	Ground	Ground	Analog ground
5	OUT1	A O	Ground	Output channel 1
6	OUT3	A O	Ground	Output channel 3
7	GND_SNS_L	A I	Ground	Line driver load ground voltage sense (left, CH 1,3,5,7)
8	OUT5	A O	Ground	Output channel 5
9	OUT7	A O	Ground	Output channel 7
10	AVCC_3V3_L	Power	Power	Analog Regulator 3.3V Supply (left)
11	AVCC_L	A O	P/D	Analog Regulator Output (left), internally supplied
12	AGND_L	Ground	Ground	Analog Ground (left)
13	VREF	A O	Ground	Bandgap Voltage reference
14	AGND_CP	Ground	Ground	Analog Ground for charge pump
15	PNEG	A O	P/D	Integrated chargepump output. Line driver negative supply.
16	C2	-	-	Line driver negative flying capacitor
17	C1	-	-	Line driver positive flying capacitor
18	AVCC_CP	Power	Power	Analog Supply for charge Pump
19	AGND_R	Ground	Ground	Analog Ground (right)
20	AVCC_R	A O	P/D	Analog regulator output (right), internally supplied
21	AVCC_3V3_R	Power	Power	Analog Regulator 3.3V Supply (right)
22	OUT8	A O	Ground	Output channel 8
23	OUT6	A O	Ground	Output channel 6
24	GND_SNS_R	A I	Ground	Line driver load ground voltage sense (right, CH 2,4,6,8)
25	OUT4	A O	Ground	Output channel 4
26	OUT2	A O	Ground	Output channel 2
27	CHIP_EN	Reset	HiZ	Active-high chip enable.
28	RT1	D I/O	HiZ	Reserved. Must be connected to DGND for normal operation.
29	SCL_SLAVE	D I/O	HiZ	I ² C slave interface serial clock input
30	SDA_SLAVE	D I/O	HiZ	I ² C slave interface data input/output
31	DATA7	D I/O	HiZ	Serial DATA7

¹ Pin 3 differs from ES9080 pinout.

	GPIO6			General I/O 6
32	DATA6	D I/O	HiZ	Serial DATA6
	GPIO5			General I/O 5
33	DATA5	D I/O	HiZ	Serial DATA5
	GPIO4			General I/O 4
34	DATA4	D I/O	HiZ	Serial DATA4
	GPIO3			General I/O 3
35	DATA3	D I/O	HiZ	Serial DATA3
	GPIO2			General I/O 2
36	DATA2	D I/O	HiZ	Serial DATA2
37	DATA1	D I/O	HiZ	Serial DATA1
38	DATA_CLK	D I/O	HiZ	Serial data clock
39	MCLK	D I/O	HiZ	MCLK input
	GPIO1			General I/O 1
	DATA8			Serial DATA8
40	DGND	Ground	Ground	Digital core ground
41	Package PAD ¹	-	-	Not electrically connected, used for heat dissipation

Table 1 - 40QFN Pin Descriptions

¹ Pin 41 is the package pad. See 40 QFN package dimensions for sizing

ES9081 Product Datasheet

Digital Features

I²C Slave Interface

The ES9081 supports a slave I²C interface. There are two types of registers, read/write registers and read-only registers.

A system clock is not required to read and write registers.

The default I²C Address is 0x90 and can be changed with Register 0[5:4] I2C_ADDR to any of: 0x90, 0x92, 0x94, 0x96

I²C Slave Interface Commands

- Connect per I²C standard
 - SDA_SLAVE (Pin 30)
 - SCL_SLAVE (Pin 29)

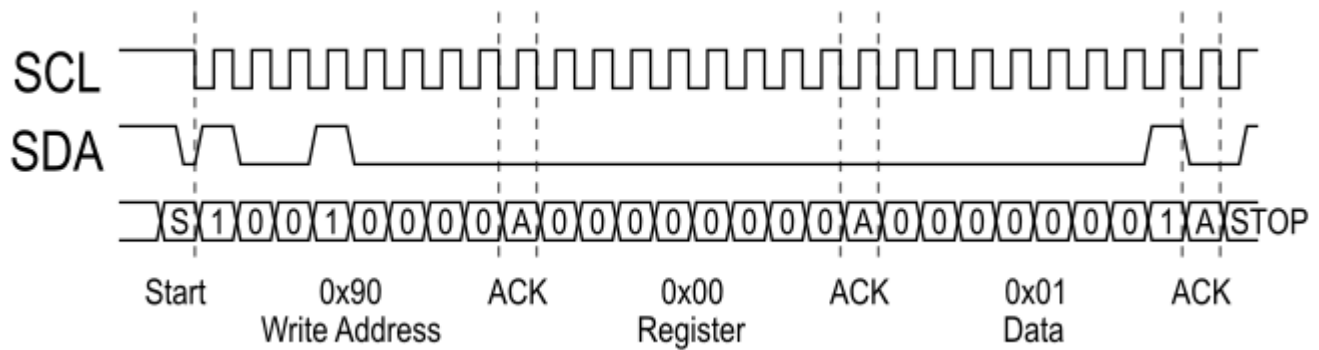

Figure 3 - I²C Write Example

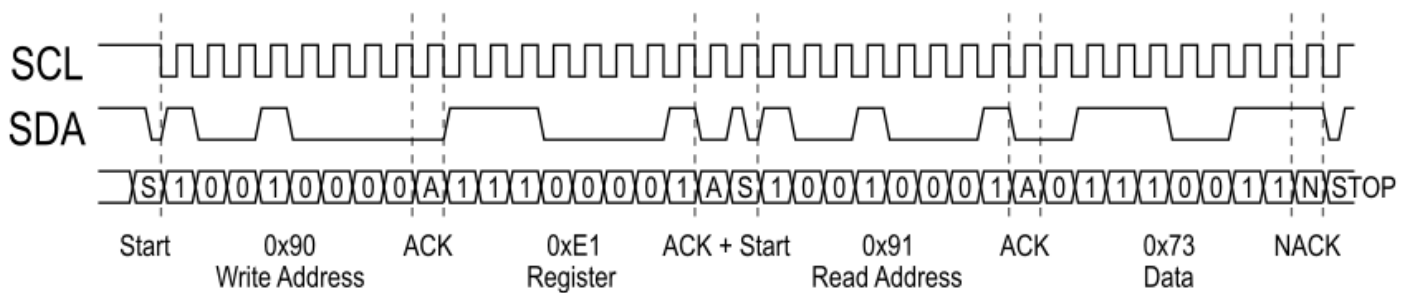

Figure 4 - I²C Read Example

Note: CHIP_ID is 0x73 in Register 225 (0xE1)

Audio Input/Output Formats

The ES9081 supports multiple serial input data formats selected via registers.

The ES9081 can automatically determine the input data format (PCM, DSD and DoP Only) by enabling Register 1[0] AUTO_INPUT_SEL, data must be provided on the DATA2 pin to properly decode the input format. The input data format can also be selected using Register 1[2:1] INPUT_SEL.

The formats include:

- PCM
 - Slave and master mode in 16, 24, 32 - bit widths
 - I²S and Left Justified (LJ)
 - Sample rates up to 768kHz (64fs mode)
 - Channel remapping & invert
- TDM
 - Up to 32 slots including daisy chain mode
 - I²S or LJ in Slave and master modes
 - Channel remapping & invert
- DoP (DSD Over PCM)
 - Slave and master mode
 - Sample rates from DoP256 (24bit, 705.5kHz PCM)
 - Channel mapping & invert
- DSD
 - Slave and master mode
 - Sample rates from DSD64 (2.8224Mbits/s, 64x44.1kHz) to DSD1024
 - Channel mapping & invert
- PDM
 - Slave and Master mode
 - Channel mapping & invert
- S/PDIF
 - Stereo 2 Channel output
 - Channel Select
 - Sample rates up to 192kHz



ES9081 Product Datasheet

PCM/TDM Decoder

The ES9081 integrates a PCM/TDM Decoder whose input has a maximum word width of 32-bits (default) and a maximum bit depth of 32-bit (default). The decoder allows for I²S, LJ, and TDM input streams.

The PCM/TDM decoder can support up to 32 different slots and each channel of the DAC can be mapped to any of the 32 slots.

PCM/TDM Decoder/Encoder Registers

- Register 6[7] TDM_RESYNC
- Register 6[6] AUTO_CH_DETECT
- Register 6[4:0] TDM_CH_NUM
- Register 7[7] ENABLE_WS_MONITOR
- Register 7[6] ENABLE_BCK_MONITOR
- Register 7[5:4] TDM_WORD_WIDTH
- Register 7[3:2] TDM_BIT_DEPTH
- Register 7[1] TDM_VALID_EDGE
- Register 7[0] TDM_LJ

PCM/TDM Decoder Mapping Registers

- Register 8-15[6:5] TDM_LINE_SEL_CHx
- Register 8-15[4:0] TDM_SLOT_SEL_CHx

Daisy Chain Registers

- Register 18[7] TDM_DAISY_CHAIN
- Register 18[6:5] TDM_DAISY_CHAIN_LINE_IN
- Register 18[4:0] TDM_DATA_LATCH_ADJ

PCM (I²S, LJ) Format

The input data is organized into 2 channels per data line, on up to 5 data lines. Each input data slot can be mapped to any DAC channel using Register 8-15[4:0] TDM_SLOT_SEL_CHx. Input data is latched on the positive edge of BCLK.

PCM Pin Connections:

Pin Name	Function	Description
DATA_CLK	PCM BCLK	PCM Clock (Bit Clock), Master or Slave
DATA1	PCM WS	PCM WS (Word Select/Frame Select), Master or Slave
DATA2	PCM DATA1	PCM Data Channel 1 & 2 (default)
DATA3	PCM DATA2	PCM Data Channel 3 & 4 (default)
DATA4	PCM DATA3	PCM Data Channel 5 & 6 (default)
DATA5	PCM DATA4	PCM Data Channel 7 & 8 (default)

Table 2 - PCM Pin Connections

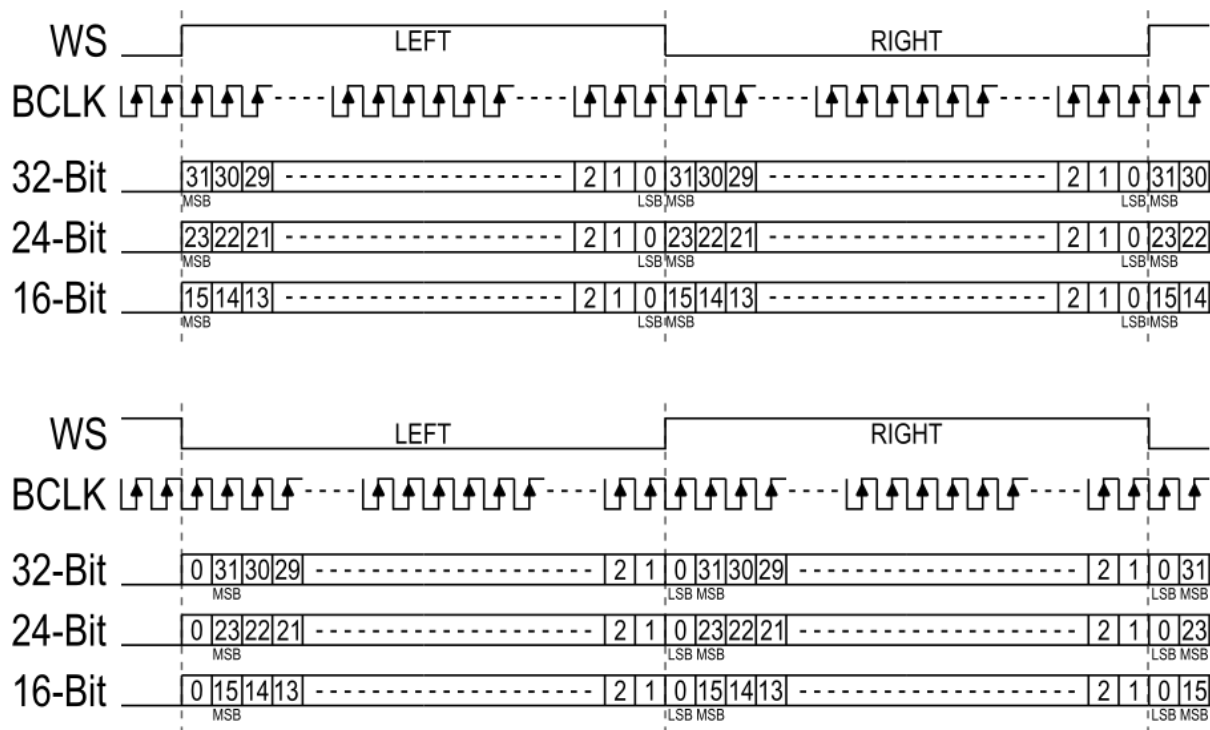

Figure 5 - LJ (top) & I²S (bottom) for 16,24, and 32-bit Word Widths

ES9081 Product Datasheet

TDM Format

The ES9081 supports TDM format, allowing for 2 to 32 channels on a single data line. The TDM data lines are to be input through DATA2-5. Input data is latched on the positive edge of BCLK.

Registers 8-15 [4:0] TDM_SLOT_SEL_CHx can be set to internally map any slot to any DAC channel.

TDM Pin Connections:

Pin Name	Function	Description
DATA_CLK	TDM BCLK	TDM Clock, Master, or Slave
DATA1	TDM WS	TDM WS (Word Select/Frame Select), Master or Slave
DATA2	TDM DATA1	TDM DATA Channel 1 & 2 (default)
DATA3	TDM DATA2	TDM DATA Channel 3 & 4 (default)
DATA4	TDM DATA3	TDM DATA Channel 5 & 6 (default)
DATA5	TDM DATA4	TDM DATA Channel 7 & 8 (default)

Table 3 - TDM Pin Connections

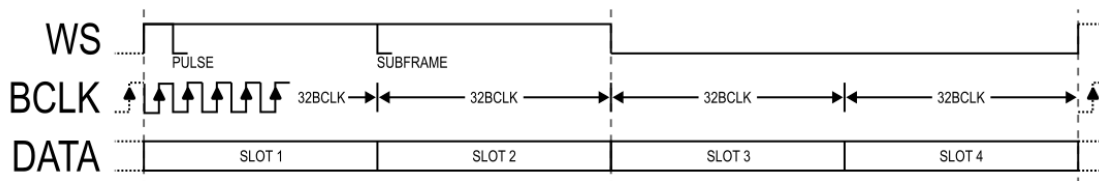

Figure 6 - TDM4 Mode

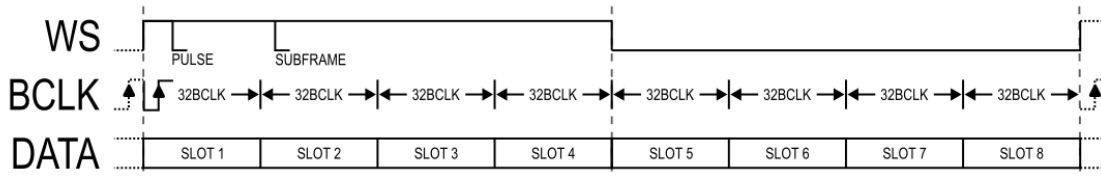

Figure 7 - TDM8 Mode

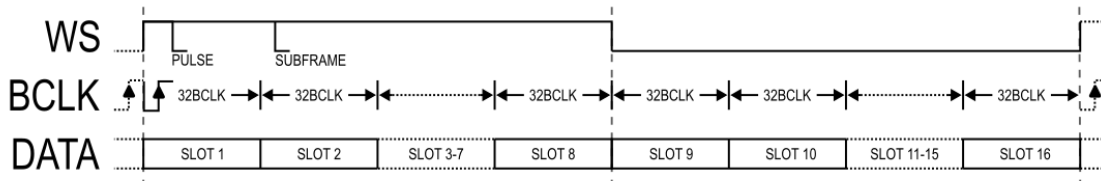

Figure 8 - TDM16 Mode

DSD Format

In DSD mode, there is a single DSD clock line, and each channel of data is an additional DSD data line. Each DSD source can be remapped to any DAC channel by using the below registers.

DSD Channel Mapping Registers

- Register 19-22[5:3][2:0] DSD_LINE_SEL_CHx

DSD Pin Connections:

Pin Name	Function	Description
DATA_CLK	DSD CLK	DSD Clock
DATA1	DSD CH1	DSD DATA Channel 1
DATA2	DSD CH2	DSD DATA Channel 2
DATA3	DSD CH3	DSD DATA Channel 3
DATA4	DSD CH4	DSD DATA Channel 4
DATA5	DSD CH5	DSD DATA Channel 5
DATA6	DSD CH6	DSD DATA Channel 6
DATA7	DSD CH7	DSD DATA Channel 7
DATA8 ¹	DSD CH8	DSD DATA Channel 8

Table 4 - DSD Pin Connections

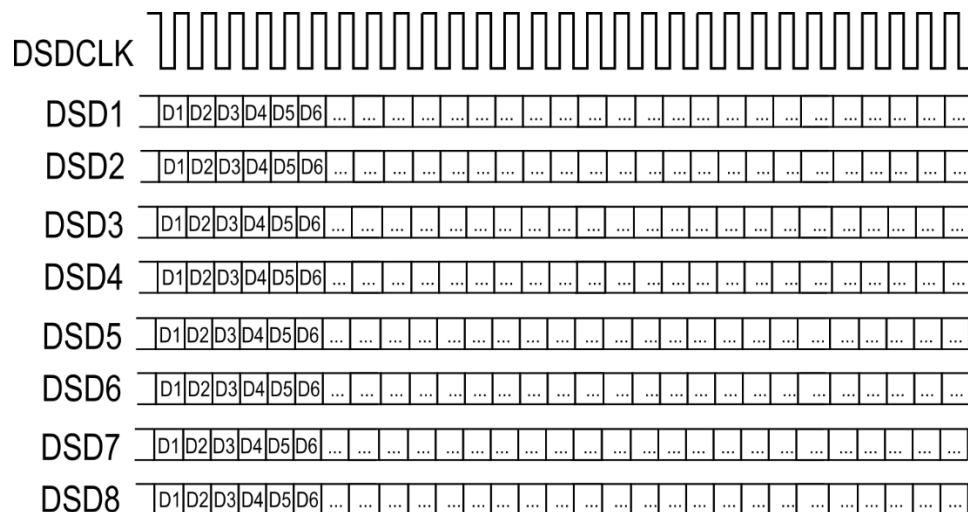

Figure 9 - DSD Format, 1-bit stream

¹ To use 8CH DSD, the MCLK/GPIO1/DATA8 pin must act as DATA8, therefore the chip must generate its MCLK from the PLL.

ES9081 Product Datasheet

PDM Decoder

PDM Data is input through the PDM decoder to be converted to DSD internally, following the rest of the respective internal data path including the DSD Channel Mapping, Automute, and DSD FIR and Volume blocks.

PDM Decoder Registers

- Register 1[7] ENABLE_PDM_DECODE
- Register 19[7] PDM_DATA_PHASE
- Register 19[6] PDM_FRAME_EDGE
- Register 20[6] PDM_2X_GAIN_EN

PDM Format

In PDM mode, there is a single PDM clock line and multiple PDM data lines containing two channels of data each. The channels can be swapped by setting Register 19[7] PDM_DATA_PHASE.

Pin Name	Function	Description
DATA_CLK	PDM CLK	PDM Clock
DATA1	PDM DATA1	PDM Data Channel 1 & 2
DATA2	PDM DATA2	PDM Data Channel 3 & 4
DATA3	PDM DATA3	PDM Data Channel 5 & 6
DATA4	PDM DATA4	PDM Data Channel 7 & 8

Table 5 - PDM Pin Connections

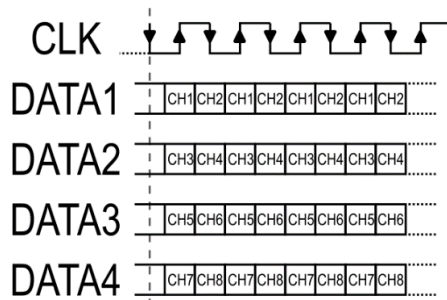

Figure 10 - PDM 8 Channel Format

S/PDIF Encoder

The ES9081 features a stereo S/PDIF encoder that can directly output a pair of channels (1/2, 3/4, 5/6, 7/8) from after the ASP or the TDM mix signal being output by the PCM/TDM Decoder. The S/PDIF channel status bits can be updated one byte at a time using the below address and data registers and toggling the write enable register to set the status bits.

Sample rates of up to 192kHz are supported

S/PDIF Encoder Registers

- Register 23[4] SPDIF_MIX_DATA_SEL
- Register 23[3:2] SPDIF_CH_PAIR_SEL
- Register 23[1] ENABLE_SPDIF_ENCODE
- Register 24[7] SPDIF_CS_WE
- Register 24[2:0] SPDIF_CS_BYTE_ADDR
- Register 25[7:0] SPDIF_CS_BYTE_DATA

Digital Signal Path

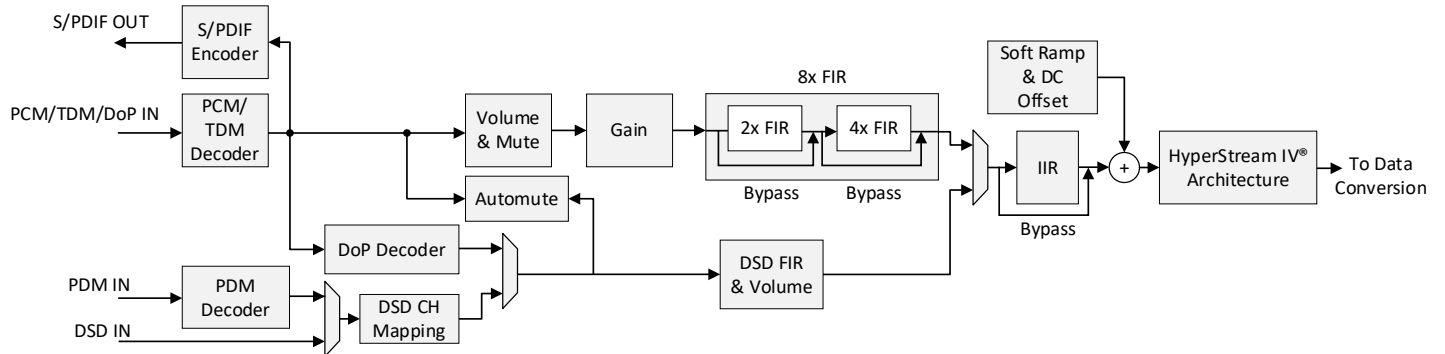

Figure 11 - Digital Signal Path

Volume Control

The Volume Control is intended for use during audio playback. Each channel can be digitally attenuated from +1dB to -126dB in 0.5dB steps. When a new volume level is set, the attenuation circuit will ramp softly to the new level at a rate specified in the VOLUME UP RAMP RATE and VOLUME DOWN RAMP RATE registers.

The ES9081 also features the ability to manually mute specific channels, invert the volume control phase as well as control all channel volumes with the CH1 volume control.

Volume Control Registers

- Register 87-94 VOLUME CHx
- Register 102 VOLUME UP RAMP RATE
- Register 103 VOLUME DOWN RAMP RATE
- Register 100 MUTE
- Register 95 PHASE INVERSION
- Register 101[6] MONO_VOLUME

ES9081 Product Datasheet

Gain

The ES9081 has a digital pre-gain of up to +42dB in 6 dB (+6,+12,+18,+24,+30,+36,+42) steps.

Gain Registers

- Register 96-99 DIGITAL GAIN

The digital pre-gain and volume control can be used together for finer resolution. Figure 19 shows the available ranges:

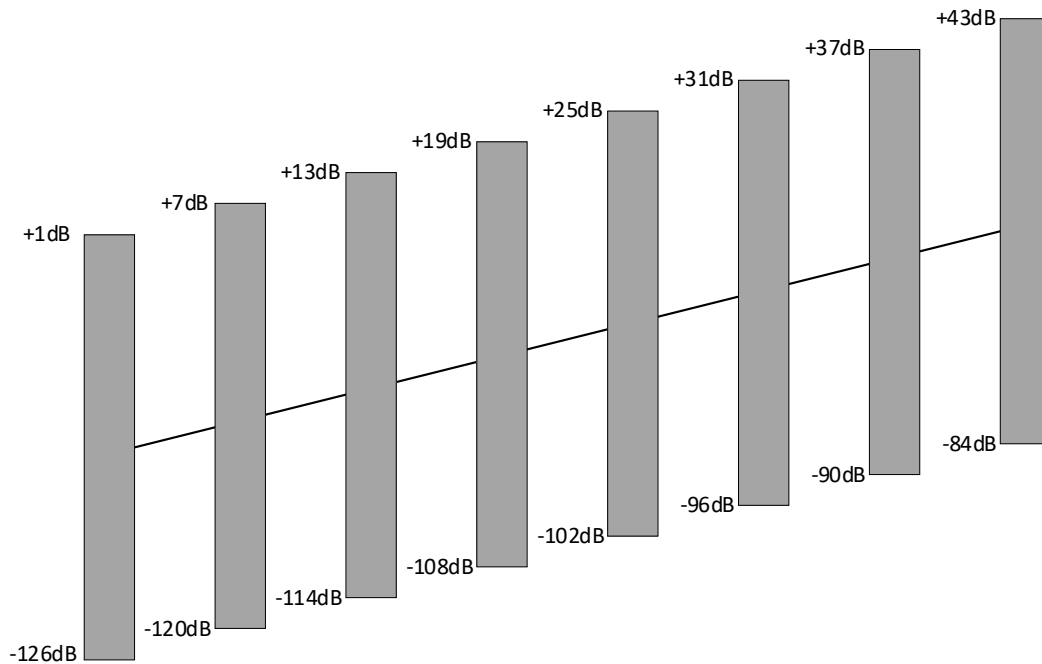

Figure 12 - ES9081 Volume Range

Automute

The ES9081 features an automute that triggers when the signal is below the specified level for longer than the specified time. The automute will disengage when the signal is above the specified off value for the same amount of time.

Note: Automute in DSD mode has additional registers that require configuration. Automute will trigger if it detects a DC level or automute patterns for the duration of automute_time.

$$Time[s] = \frac{2^{18} * 2^{64FS_MODE}}{AUTOMUTE_TIME * FS}$$

$$Level[dB] = \frac{20 * \log_{10}(AUTOMUTE_LEVEL)}{(2^{16} - 1) * 2^7}$$

$$Level_{OFF}[dB] = \frac{20 * \log_{10}(AUTOMUTE_OFF_LEVEL)}{(2^{16} - 1) * 2^7}$$

Automute Registers

- Register 105 AUTOMUTE_ENABLE
- Register 106-107 [10:0] AUTOMUTE_TIME
- Register 108-109 AUTOMUTE_LEVEL
- Register 110-111 AUTOMUTE_OFF_LEVEL

DSD Automute Settings Registers

- Register 106-107[15] DSD_FAULT_DETECT_EN
- Register 106-107[14] DSD_DC_AM_ENB
- Register 106-107[13] DSD_MUTE_AM_ENB

8x FIR Filter

Selection of the 8x interpolation filter is chosen from 8 pre-programmed filters. The 2x and 4x filter can be bypassed individually or together. For more information on filters see the Pre-Programmed Digital Filters section.

8x FIR Registers

- Register 86[2:0] FILTER_SHAPE
- Register 86[3] BYPASS_FIR2X
- Register 86[4] BYPASS_FIR4X

IIR Filter

The IIR filter can be bypassed using Register 86[5] BYPASS_IIR

Soft Ramp & DC Offset

The ES9081 saves power by ramping to ground during a normal mute condition. This includes automute, register mute, and, GPIO mute.

A DC offset can be added to all 8 datapath signals in 100uV increments.

Soft Ramp & DC Offset Registers

- Register 101[5] MUTE_RAMP_TO_GROUND
- Register 101[4:0] SOFT_RAMP_TIME
- Register 104 DC_OFFSET

ES9081 Product Datasheet

GPIO Configuration

GPIO_CONFIG	Function	I/O Direction
0	Analog Outputs Off	Shutdown
1	Output 1'b0	Output
2	Output 1'b1	Output
3	Clock Valid	Output
4	PLL Locked Flag	Output
5	DAC Minimum Volume Flag	Output
6	DAC Automute Status	Output
7	DAC Soft Ramp Done Flag	Output
8	Mute DAC	Input
9	System Mode Control	Input
10	OR of Status Bits	Output
11	S/PDIF Stream	Output
12	PWM Signal	Output
13	MCLK_128FS	Output
14	Reserved	-
15	Reserved	-

Table 6 - GPIO Configuration

Analog Outputs Off

The GPIO is shutdown and has no functionality.

Output 1'b0

Outputs a constant 1'b0.

Output 1'b1

Outputs a constant 1'b1.

Clock Valid

Outputs HIGH if a MCLK source is detected. Outputs LOW when clock is removed or not present.

Note: Must have Register 3[1] EN_CLK_DET set for detection circuit to function.

PLL Locked Flag

Outputs HIGH if the PLL is locked.

DAC Minimum Volume Flag

Outputs HIGH when the DAC is muted. This can occur from manually muting via GPIO or a register, automuting, setting volume to 0xFF, loss of PLL lock, or an invalid MCLK/BCK ratio is detected via Register 7[6] ENABLE_BCK_MONITOR.

Relevant Registers

- Register 74-75[13] GPIO_AND_VOL_MIN sets the output to be the logical AND of both channels' mute flags.
- Register 76-77[13] GPIO_OR_VOL_MIN sets the output to be the logical OR of both channels' mute flags.

DAC Automute Status

Outputs HIGH when the DACs automute condition is met.

Relevant Registers

- Register 74-75[14] GPIO_AND_AUTOMUTE sets the output to be the logical AND of both channels' automute flags.
- Register 76-77[14] GPIO_OR_AUTOMUTE sets the output to be the logical OR of both channels' automute flags.

DAC Soft Ramp Done Flag

Outputs HIGH when the DAC is neither ramping up nor down.

Relevant Registers

- Register 74-75[15] GPIO_AND_SS_RAMP sets the output to be the logical AND of both channels' automute flags.
- Register 76-77[15] GPIO_OR_SS_RAMP sets the output to be the logical OR of both channels' automute flags.

Mute DAC

Mute all DAC channels.

System Mode Control

Sets the ability to turn the DAC on and off via a GPIO.

Relevant Registers

- Register 72-73[14] GPIO_FSM_MODE sets whether the GPIO has an enable or enable bar functionality
 - GPIO_FSM_MODE = 1'b0: Disable datapath when the GPIO input is 1'b1
 - GPIO_FSM_MODE = 1'b1: Enable datapath when the GPIO input is 1'b1.
- Note: When GPIO_FSM_MODE = 1'b0, the system mode will be determined by Register 0[0] ENABLE_DAC_REG

OR of Status Bits

Outputs the logical OR of all the currently masked status flags.

Relevant Registers

- Registers 36-38 STATUS BITS MASKP 1-4
- Registers 39-43 STATUS BITS MASKN 1-4
- Registers 44-47 STATUS BITS CLEAR 1-4

S/PDIF Stream

Outputs the S/PDIF stream. Requires Register 23[1] ENABLE_SPDIF_ENCODE to be set.

ES9081 Product Datasheet

PWM Signal

Outputs a configurable PWM signal. The frequency and duty cycle of the PWM signal can be calculated with the following equations:

$$frequency [Hz] = \frac{MCLK}{PWM_FREQ + 1}$$
$$Duty Cycle [\%] = \left(\frac{PWM_COUNT}{PWM_FREQ + 1} \right) \times 100$$

Relevant Registers

- Register 82 PWM COUNT
- Register 83-84 PWM FREQUENCY

MCLK_128FS

Outputs the MCLK_128FS clock. Requires the DAC to be on.

$$MCLK_128FS = \frac{FS * 2^7}{2^{64FS_MODE}}$$

Pre-Programmed Digital Filters

The ES9081 has 8 pre-programmed digital filters. The latency for each filter reduces (scales) with increasing sample rates. (See Register 86[2:0] FILTER_SHAPE for configuration)

#	Filter	Description
1	Minimum Phase (default)	Version 2 of minimum phase fast roll-off (#6) with less ripple and more image rejection
2	Linear Phase Apodizing Fast Roll-Off	Full image rejection by FS/2 to avoid any aliasing, with smooth roll-off starting before 20k.
3	Linear Phase Fast Roll-Off	Sabre legacy filter, optimized for image rejection @ 0.55FS
4	Linear Phase Fast Roll-Off Low-Ripple	Sabre legacy filter, optimized for in-band ripple
5	Linear Phase Slow Roll-Off	Sabre legacy filter, optimized for lower latency, but symmetric impulse response
6	Minimum Phase Fast Roll-Off	Low latency, minimal pre ringing and low passband ripple, image rejection @ 0.55FS
7	Minimum Phase Slow Roll-Off	Lowest latency at the cost of image rejection
8	Minimum Phase Fast Roll-Off Low Dispersion	Provides a nice balance of the low latency of minimum phase filters and the low dispersion of linear phase filters. Minimal pre-ringing is added to achieve the low dispersion in the audio band.

Table 7 - Pre-Programmed Digital Filter Descriptions

Note: Minimum phase filters are asymmetric filters that work to minimize the pre-echo of the filter, while still maintaining an excellent frequency response and they peak earlier than linear phase filters, resulting in a lower group delay. Minimum phase filters usually feature zero cycles of pre-echo, which can result in improved audio quality.

ES9081 Product Datasheet

PCM Filter Latency

The following table shows the simulated latency of each filter at 44.1kHz sampling rate. Measurements were taken from the external impulse response. The extra sample delay to get the data encoded accounts for external processing time to serialize the data stream. Latency will reduce (scale) with sampling rate.

Digital Filter	Delay
Minimum Phase (default)	5.34 / FS
Linear Phase Apodizing Fast Roll-Off	34.70 / FS
Linear Phase Fast Roll-Off	35.33 / FS
Linear Phase Fast Roll-Off Low-Ripple	33.27 / FS
Linear Phase Slow Roll-Off	7.78 / FS
Minimum Phase Fast Roll-Off	5.32 / FS
Minimum Phase Slow Roll-Off	4.36 / FS
Minimum Phase Fast Roll-Off Low Dispersion	11.3 / FS

Table 8 - PCM Filter Latency

PCM Filter Properties

Minimum Phase					
Parameter	Conditions	MIN	TYP	MAX	UNIT
Pass band				0.46 FS	Hz
Stop band	-96.61 dB	0.55 FS			Hz
Group Delay		2.91/FS		9.01/FS	s
Flatness (ripple)	0.0013				dB

Linear Phase Apodizing					
Parameter	Conditions	MIN	TYP	MAX	UNIT
Pass band				0.41 FS	Hz
Stop band	-106.1 dB	0.50 FS			Hz
Group Delay			32.81 FS		s
Flatness (ripple)	0.0029				dB

Linear Phase Fast Roll-Off					
Parameter	Conditions	MIN	TYP	MAX	UNIT
Pass band				0.45 FS	Hz
Stop band	-110.5 dB	0.55 FS			Hz
Group Delay			33.43/FS		s
Flatness (ripple)	0.0032				dB

Linear Phase Fast Roll-Off Low Ripple					
Parameter	Conditions	MIN	TYP	MAX	UNIT
Pass band				0.46 FS	Hz
Stop band	-89.1 dB	0.55 FS			Hz
Group Delay			31.37/FS		s
Flatness (ripple)	0.0013				dB

Linear Phase Slow Roll-Off					
Parameter	Conditions	MIN	TYP	MAX	UNIT
Pass band	-3 dB			0.44 FS	Hz
Stop band	-90.7	0.75 FS			Hz
Group Delay			5.87/FS		s
Flatness (ripple)					dB

Minimum Phase Fast Roll-Off					
Parameter	Conditions	MIN	TYP	MAX	UNIT
Pass band				0.46 FS	Hz
Stop band	-97.96 dB	0.55 FS			Hz
Group Delay		2.91/FS		9.14/FS	s
Flatness (ripple)	0.0023				dB



ES9081 Product Datasheet

Minimum Phase Slow Roll-Off					
Parameter	Conditions	MIN	TYP	MAX	UNIT
Pass band	-3 dB			0.43 FS	Hz
Stop band	-90.9 dB	0.80 FS			Hz
Group Delay		2.08/FS		3.56/FS	s
Flatness (ripple)					dB

Minimum Phase Slow Roll-Off Low Dispersion					
Parameter	Conditions	MIN	TYP	MAX	UNIT
Pass band	-3 dB			0.43 FS	Hz
Stop band	-91 dB	0.80 FS			Hz
Group Delay		9.23/FS		9.75/FS	s
Flatness (ripple)					dB

Table 9 - PCM Filter Properties

PCM Filter Frequency Response

The following frequency responses were obtained from software simulations of these filters. Simulation sample rate is 44.1kHz.

Filter	Frequency Response
Minimum Phase	<p>Frequency Response at FS = 44.1 kHz</p>
Linear Phase Apodizing	<p>Frequency Response at FS = 44.1 kHz</p>

ES9081 Product Datasheet

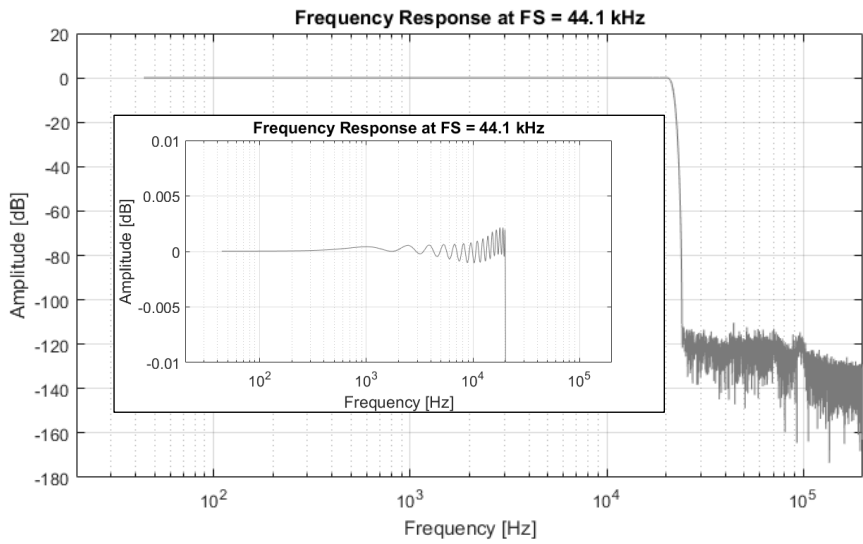
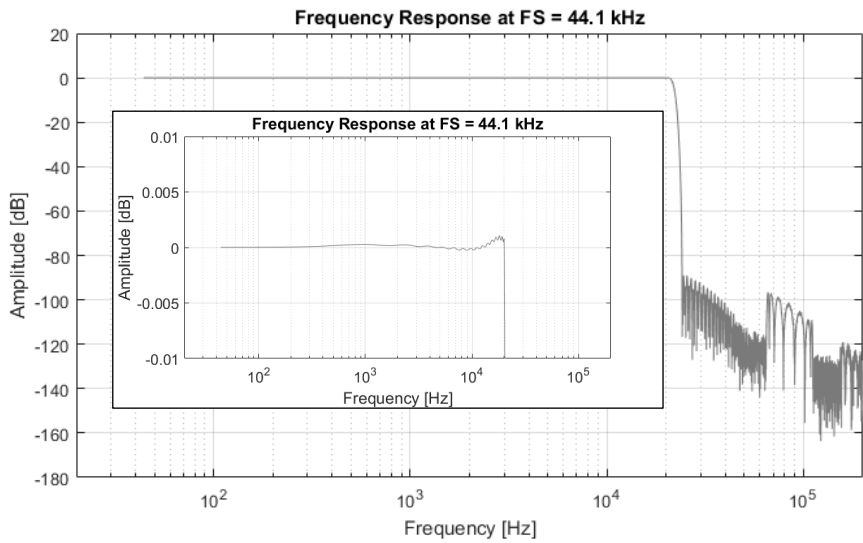
<p>Linear Phase Fast Roll-Off</p>	
<p>Linear Phase Fast Roll-Off Low Ripple</p>	

<p>Linear Phase Slow Roll-Off</p>	
<p>Minimum Phase Fast Roll-Off</p>	

ES9081 Product Datasheet

<p>Minimum Phase Slow Roll-Off</p>	
<p>Minimum Phase Slow Roll-Off Low Dispersion</p>	

Table 10 - PCM Filter Frequency Response

PCM Filter Impulse Response

The following impulse responses were obtained from software simulations of these filters. They were measured from the external impulse response. The extra sample delay to get the data encoded accounts for external processing time to serialize data stream.

Filter	Impulse Response
Minimum Phase	
Linear Phase Apodizing	

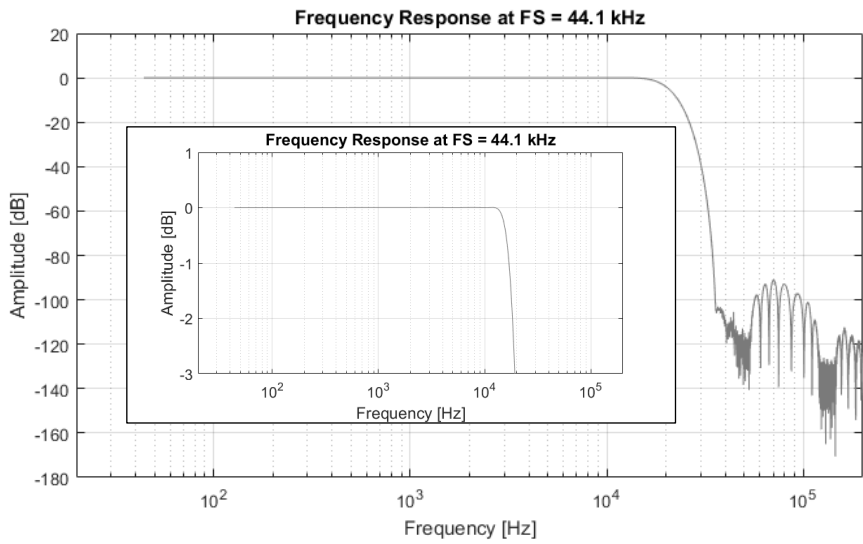
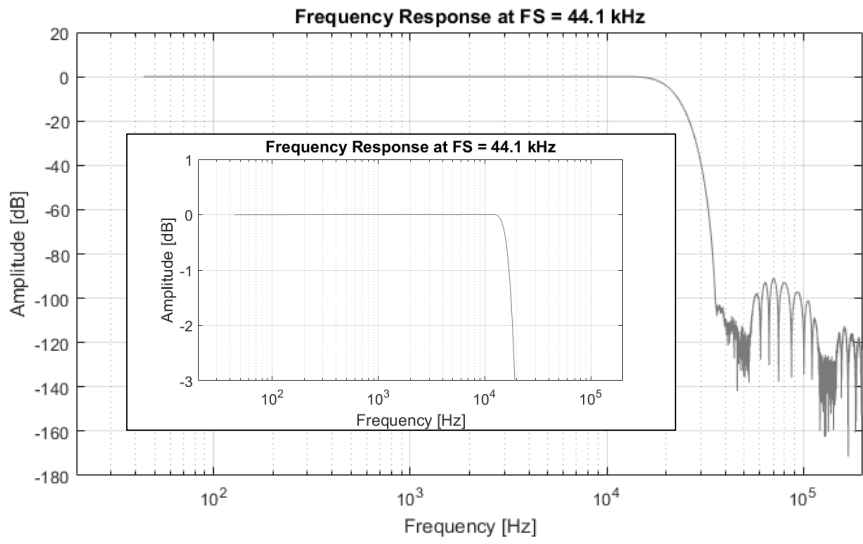
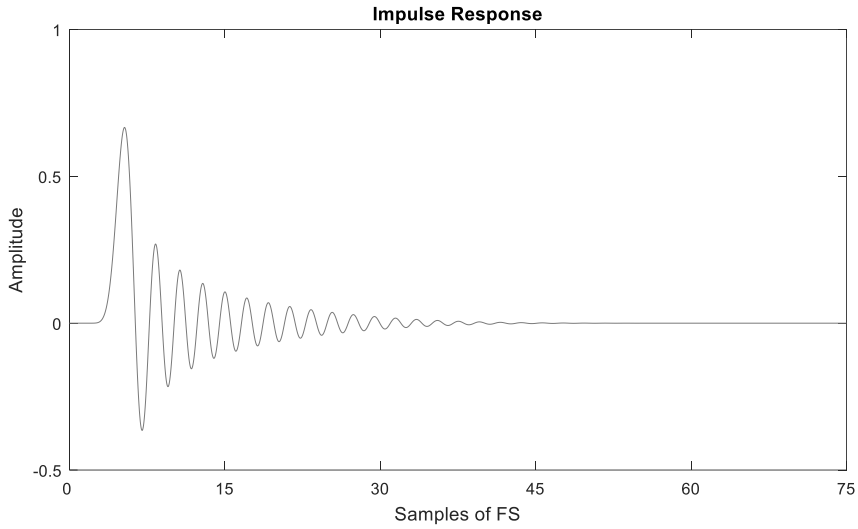
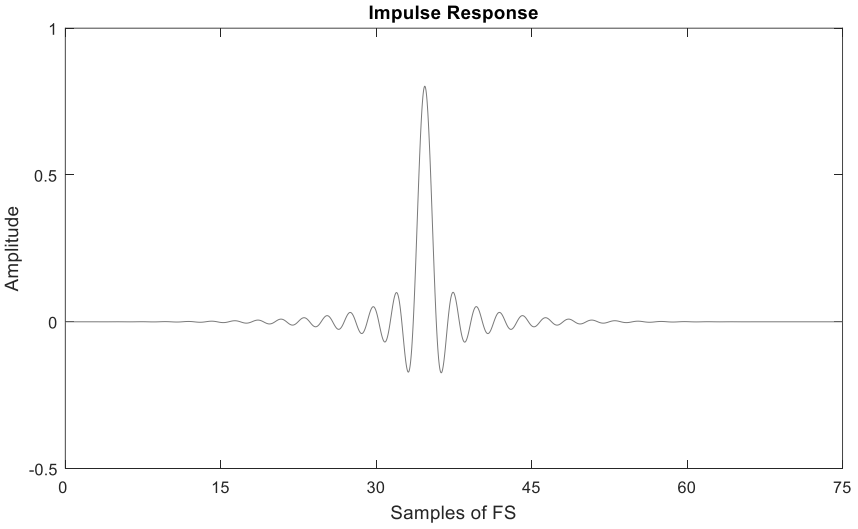
ES9081 Product Datasheet

Linear Phase Fast Roll-Off

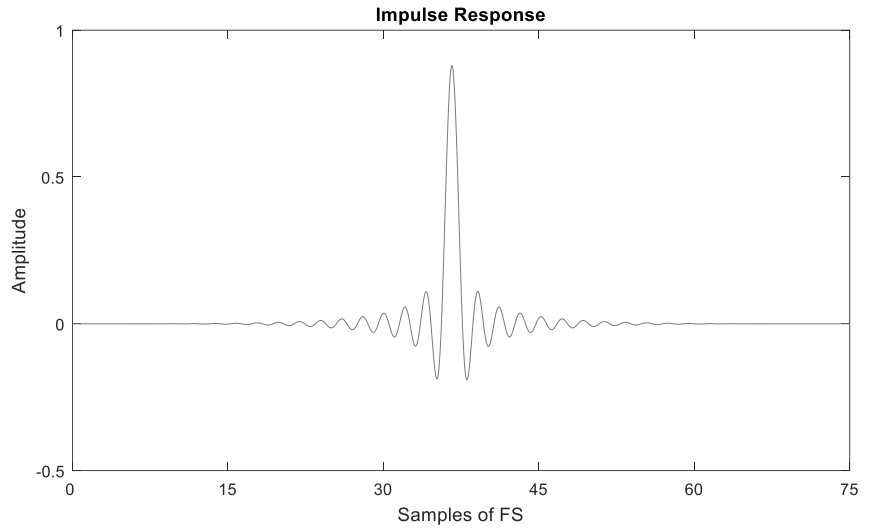

Linear Phase Fast Roll-Off
Low Ripple

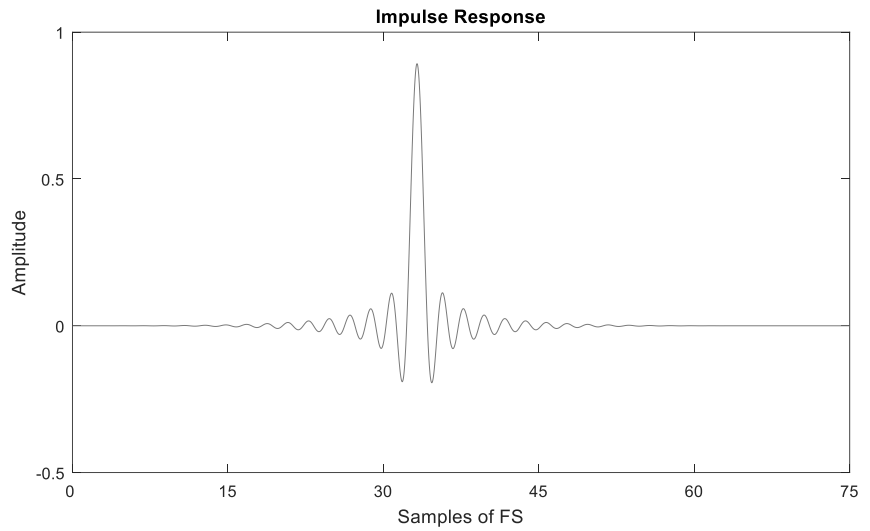

Linear Phase Slow Roll-Off

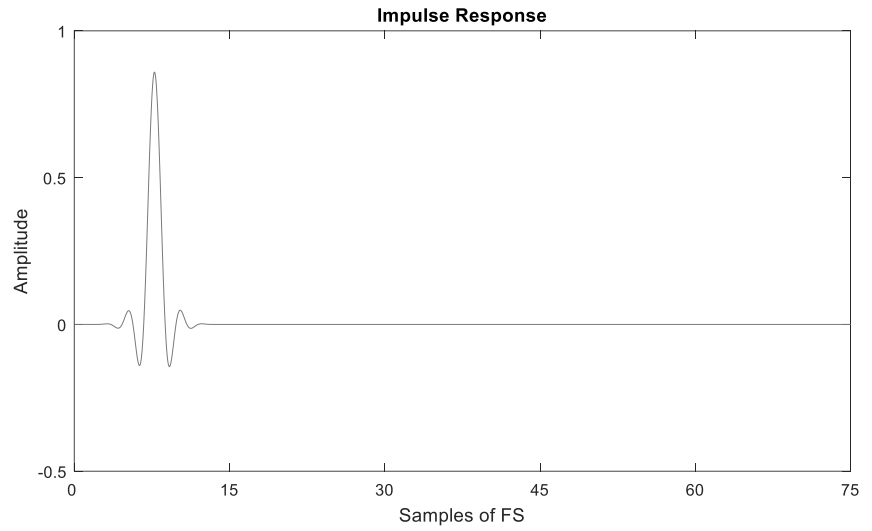

Minimum Phase Fast Roll-Off

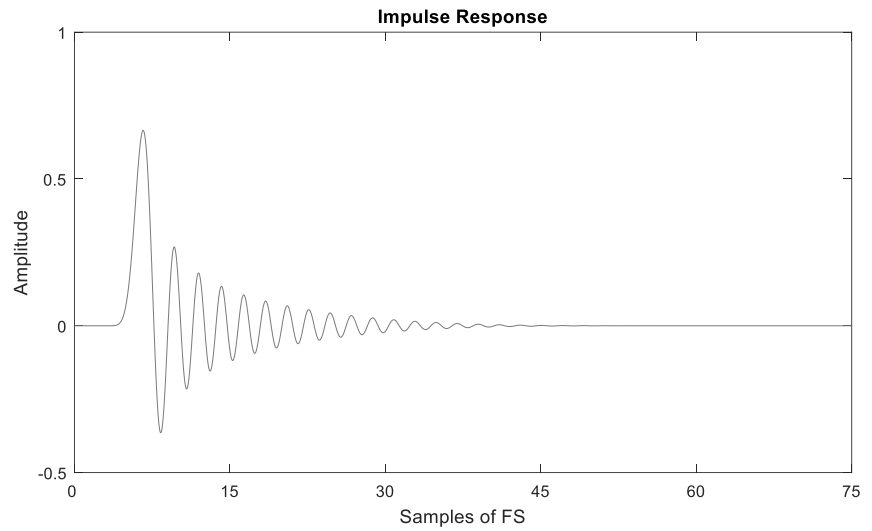

ES9081 Product Datasheet

<p>Minimum Phase Slow Roll-Off</p>	
<p>Minimum Phase Slow Roll-Off Low Dispersion</p>	

Table 11 - PCM Filter Impulse Response

64FS Mode

When the MCLK/FS ratio is required to be 64, it is necessary for the ES9081 to be in 64FS mode. 64FS Mode can be enabled by setting:

Registers

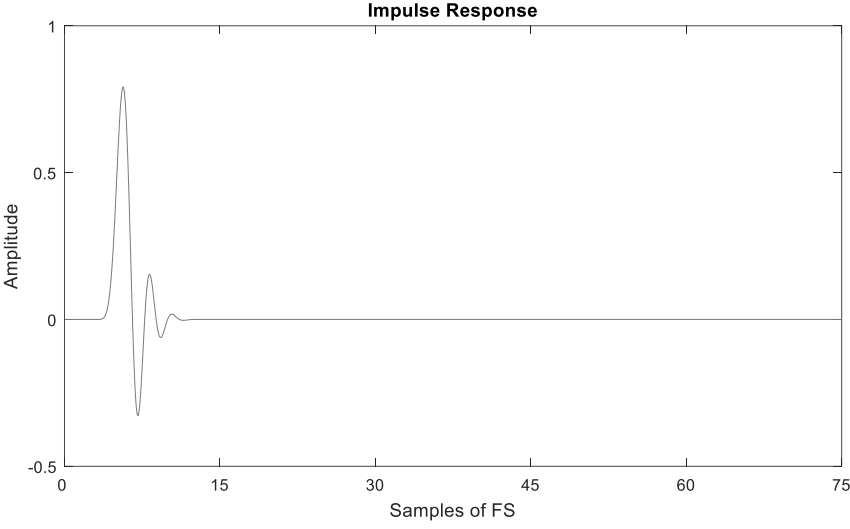
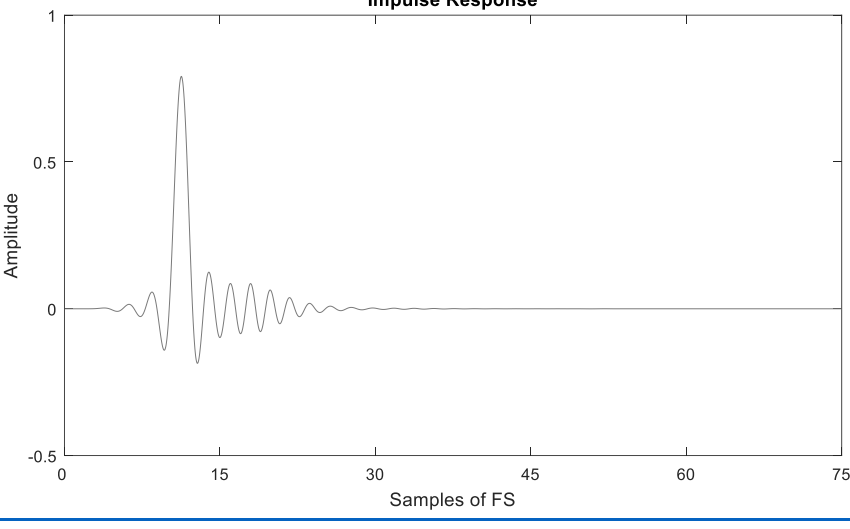
- Register 0[1] ENABLE_64FS_MODE = 1'b1
 - Manually enables 64FS mode
 - Should be used with high sample rates like 705.6kHz & 768kHz
- Register 0[2] AUTO_FS_DETECT = 1'b1
 - Sets the MCLK_128FS divider according to MCLK/FS ratio
 - Automatically enables 64FS mode when MCLK/MCLK_128FS ratio is 64
- 64FS mode can be blocked when AUTO_FS_DETECT is enabled by setting:
 - Register 0[3] AUTO_FS_BLOCK_64FS = 1'b1

Minimum Phase 64FS Mode Latency

The following table shows the simulated latency at 705.6kHz sampling rate and is very similar at 768kHz. Measurements were taken from the external impulse response. The extra sample delay to get the data encoded accounts for external processing time to serialize the data stream. Latency delay will reduce (scale) with sampling rate.

Digital Filter	Delay
Minimum Phase 64FS	3.67 / FS

Table 12 - Minimum Phase 64FS Latency

Minimum Phase 64FS Properties

Minimum Phase 64FS Mode					
Parameter	Conditions	MIN	TYP	MAX	UNIT
Pass band	-3 dB			0.45 FS	Hz
Stop band	-61.29 dB	0.68 FS			Hz
Group Delay		1.54/FS		2.35/FS	s
Flatness (ripple)					dB

Table 13 - Minimum Phase 64FS Properties

ES9081 Product Datasheet

Minimum Phase 64FS Frequency Response

This filter gets selected automatically when $MCLK/FS = 64$. The following frequency response was obtained from software simulations with a sample rate of 705.6kHz

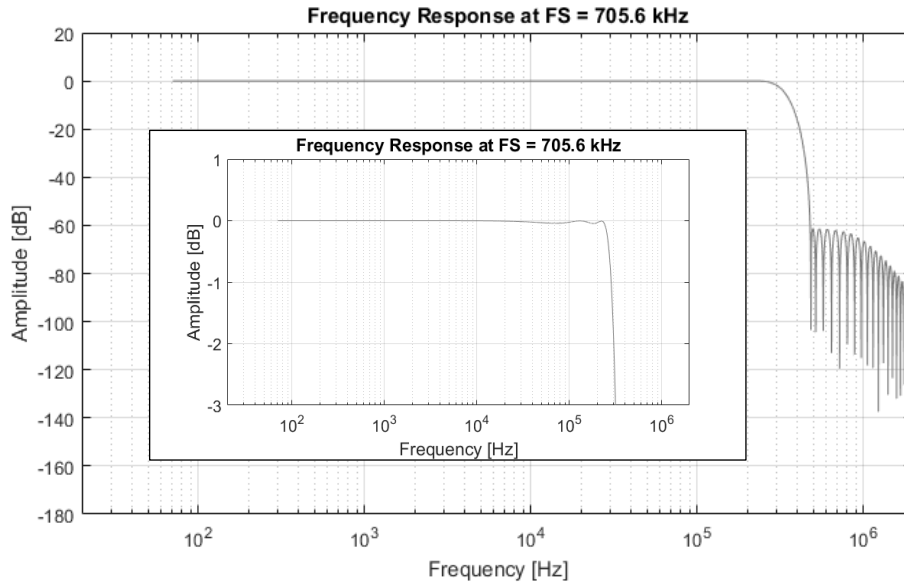

Figure 13 - Minimum Phase 64FS Frequency Response

The following impulse responses were obtained from software simulations of these filters. They were measured from the external impulse response. The extra sample delay to get the data encoded accounts for external processing time to serialize data stream.

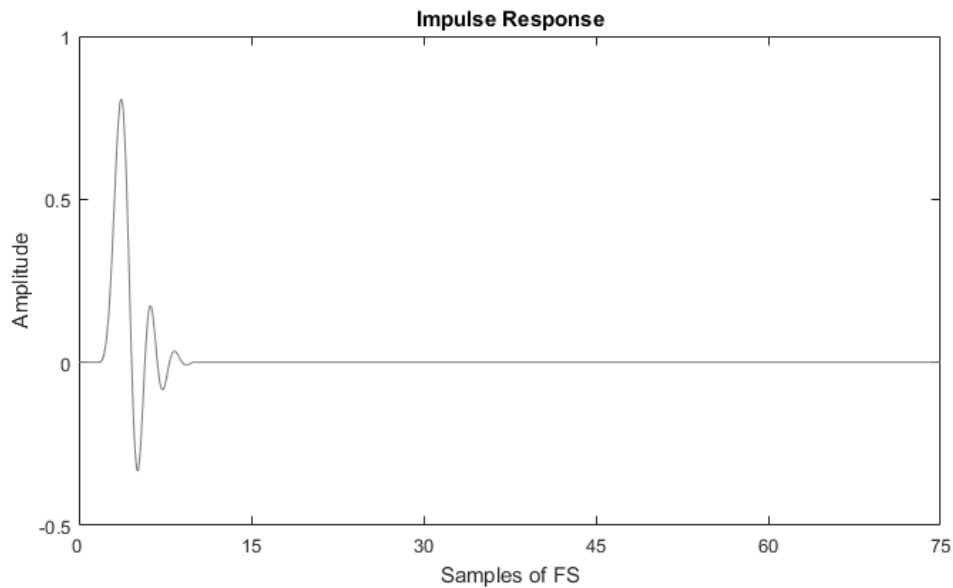

Figure 14 - Minimum Phase 64FS Impulse Response

Analog Features

APLL

The ES9081 has a built in Analog PLL (APLL) for generating frequencies that are unavailable externally. For an application note on the APLL, please ask your FAE or distributor for availability.

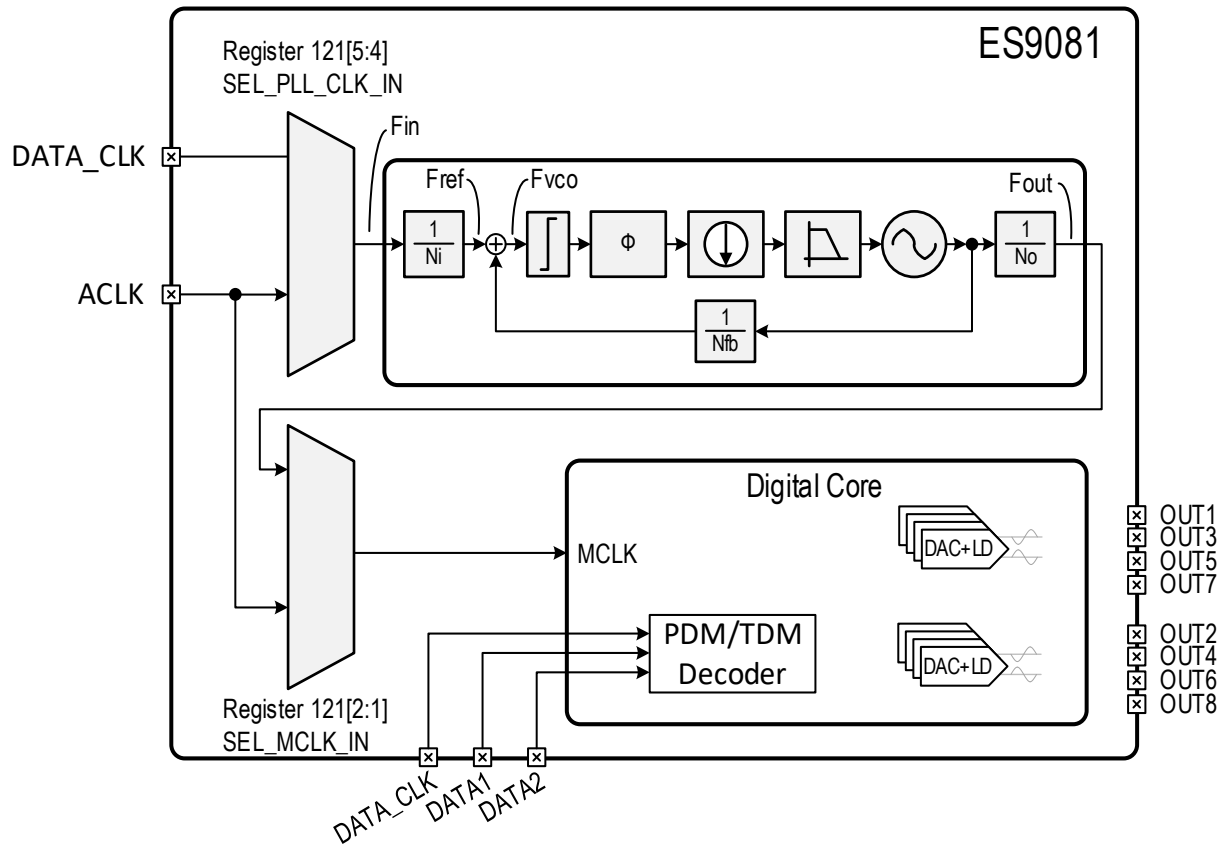

Figure 15 - Functional Block Diagram of ES9081 APLL

The input clock (F_{in}) source to the APLL is chosen between ACLK or DATA_CLK with Register 121[5:4] SEL_PLL_CLK_IN. The input MCLK source to the chip is chosen between the APLLs output or the ACLK pin with Register 121[2:1] SEL_MCLK_IN.

ES9081 Product Datasheet

For calculation of the PLL frequency output, use the following formulas:

$$F_{ref} = \left(\frac{F_{in}}{N_i} \right) \quad F_{vco} = \left(\frac{F_{in}}{N_i} \right) * N_{fb} \quad N_{fb} = \frac{2^{25}}{FBDIV} \quad F_{out} = \left(\frac{F_{in}}{N_i} \right) * \frac{N_{fb}}{N_o}$$

Where:

- a. FBDIV is a 24-bit number
- b. PLL frequency range requirements:
 - a. Fref requirement: 2.5MHz < Fref < 12 MHz
 - b. Fvco requirement: 90MHz < Fvco < 110MHz
 - c. Fout requirement: 22.5792/24.576MHz & 45.1584/49.152Mhz
- c. Ni = input divider
 - Accessible from Reg 127-129[8:0], PLL_CLK_IN_DIV
- d. No = output divider
 - Accessible from Reg 127-129[15:12], PLL_CLK_OUT_DIV
- e. Nfb = feedback divider
 - Accessible from Reg 124-126[23:0], PLL_CLK_FB_DIV
 - Note: Toggle Reg 127-129 PLL_FB_DIV_LOAD to load PLL_CLK_FB_DIV value

44.1kHz Base Rates (SYNC Slave Mode)							
FS (kHz)	DATA_CLK (MHz)	Ni	Fref (MHz)	FBDIV	Fvco (MHz)	No	Fout (MHz)
32-Bit Frame							
352.8	22.5792	2	11.2896	4194304	90.3168	4	22.5792
176.4	11.2896	1	11.2896	4194304	90.3168	4	22.5792
88.2	5.6448	1	5.6448	2097152	90.3168	4	22.5792
44.1	2.8224	1	2.8224	1048576	90.3168	4	22.5792
16-Bit Frame							
352.8	11.2896	1	11.2896	4194304	90.3168	4	22.5792
176.4	5.6448	1	5.6448	2097152	90.3168	4	22.5792
88.2	2.8224	1	2.8224	1048576	90.3168	4	22.5792
44.1	1.4112	1	1.4112	524288	90.3168	4	22.5792

Table 14 - APLL Divider Values for 44.1kHz Base Rates

48kHz Base Rates (SYNC Slave Mode)							
FS (kHz)	DATA_CLK (MHz)	Ni	Fref (MHz)	FBDIV	Fvco (MHz)	No	Fout (MHz)
32-Bit Frame							
384	24.576	2	12.288	4194304	98.304	4	24.576
192	12.288	1	12.288	4194304	98.304	4	24.576
96	6.144	1	6.144	2097152	98.304	4	24.576
48	3.072	1	3.072	1048576	98.304	4	24.576
16-Bit Frame							
384	12.288	1	12.288	4194304	98.304	4	24.576
192	6.144	1	6.144	2097152	98.304	4	24.576
96	3.072	1	3.072	1048576	98.304	4	24.576
48	1.536	1	1.536	524288	98.304	4	24.576

Table 15 - APLL Divider Values for 48kHz Base Rates

Absolute Maximum Ratings

PARAMETER	RATING
Positive Supply Voltage <ul style="list-style-type: none"> • AVCC_3V3_L • AVCC_3V3_R • AVCC_CP • AVDD • DVDD 	<ul style="list-style-type: none"> • +3.7V with respect to ground • +3.7V with respect to ground • +3.7V with respect to ground • +3.7V with respect to ground • +1.4V with respect to ground
Storage Temperature	-65°C to +150°C
Operating Junction Temperature	+125°C
Voltage Range for Digital Input Pins	-0.3V to AVDD (nom) +0.3V

Table 16 - Absolute Maximum Ratings

WARNING: Stresses beyond those listed under here may cause permanent damage to the device. These are stress ratings only and functional operation of the device at these or any other conditions beyond those indicated under Recommended Operating Conditions is not implied.

ESD Ratings

ESD Standard	Rating
Human Body Model (HBM), ANSI/ESDA/JEDEC JS-001	2kV
Charge Device Model (CDM), ANSI/ESDA/JEDEC JS-002	500V

Table 17 - ESD Ratings

WARNING: Electrostatic Discharge (ESD) can damage this device. Proper procedures must be followed to avoid ESD when handling this device.

IO Electrical Characteristics

PARAMETER	SYMBOL	MINIMUM	MAXIMUM	UNIT
High-level input voltage	VIH	$(AVDD / 2) + 0.4$		V
Low-level input voltage	VIL		0.4	V
High-level output voltage	VOH	$AVDD - 0.2$		V
Low-level output voltage	VOL		0.2	V

Table 18 - I/O Electrical Characteristics

ES9081 Product Datasheet

Switching Characteristics

Parameter	Notes	Min.	Typ.	Max.	Unit
MCLK¹					
Frequency		6.144	-	49.152	MHz
Duty Cycle		45	-	55	%
PCM Mode					
WS Frequency (Word Select Clock)		8	-	MCLK/128	kHz
BCLK Frequency (Bit Clock)		(16*2*WS)	TDM_WORD_WIDTH)* (TDM_CH_NUM+1)*WS	MCLK	MHz
WS Frequency (Word Select Clock)	64FS Mode ²	352.8	MCLK/64	768	kHz
BCLK Frequency (Bit Clock)		22.5792	MCLK	49.152	MHz
TDM Mode					
WS Frequency (Word Select Clock)	TDM4	8	-	MCLK/128	kHz
	TDM8		-	MCLK/256	kHz
	TDM16		-	MCLK/512	kHz
	TDM32		-	MCLK/1024	kHz
BCLK Frequency (Bit Clock)		(16*2*WS)	(TDM_WORD_WIDTH)* (TDM_CH_NUM+1)*WS	MCLK	MHz
DSD Mode					
DSD Clock Frequency		2.8224	-	MCLK/2	MHz

Table 19 - Switching Characteristics

¹ MCLK must be synchronous to the digital audio clock

² 64FS mode is for 705.6/768kHz with 45.1584/49.152MHz or 352.8/384kHz with 22.5792/24.576MHz.

Timing Characteristics

Bit-Clock (BCLK) and Word-Select (WS) Timing

Test Conditions 1 (unless otherwise noted)

$T_A = 25^\circ\text{C}$, $AVCC_3V3_L = AVCC_3V3_R = AVCC_CP = AVDD = +3.3\text{V}$, $DVDD = \text{Internal}$, $f_s = 48\text{kHz}$, DAC enabled, 1kHz sine full scale.

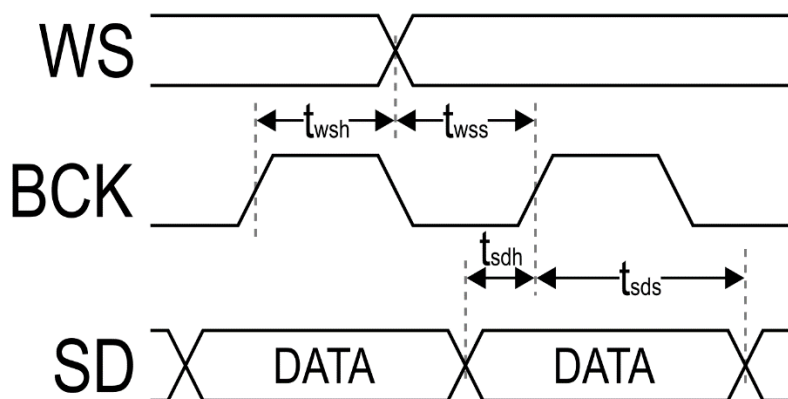

Figure 16 - Bit-Clock and Word-Select Timing

Parameter	Symbol	Min.	Typ.	Max.	Unit
WS setup time	t_{wss}	-	0.3	-	ns
WS hold time	t_{wsh}	-	0.3	-	ns
SD setup time	t_{sds}	-	-0.4	-	ns
SD hold time	t_{sdh}	-	0.8	-	ns

Table 20 - Bit-Clock and Word-Select Timing Definitions

ES9081 Product Datasheet

I²C Slave Interface Timing

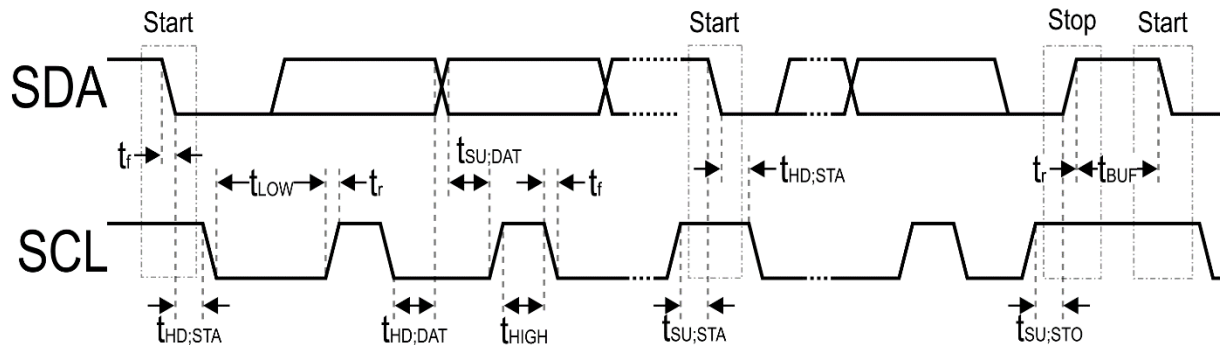

Figure 17 - I²C Slave Control Interface Timing

Parameter	Symbol	CLK Constraint	Standard-Mode		Fast-Mode		Unit
			MIN	MAX	MIN	MAX	
SCL Clock Frequency	f_{SCL}	$< CLK/20$	0	100	0	400	kHz
START condition hold time	$t_{HD,STA}$		4.0	-	0.6	-	μs
LOW period of SCL	t_{LOW}	$>10/CLK$	4.7	-	1.3	-	μs
HIGH period of SCL ($>10/CLK$)	t_{HIGH}	$>10/CLK$	4.0	-	0.6	-	μs
START condition setup time (repeat)	$t_{SU,STA}$		4.7	-	0.6	-	μs
SDA hold time from SCL falling	$t_{HD,DAT}$		0	-	0	-	μs
- All except NACK read - NACK read only			$2/CLK$	-	$2/CLK$	-	s
SDA setup time from SCL rising	$t_{SU,DAT}$		250	-	100	-	ns
Rise time of SDA and SCL	t_r		-	1000	-	300	ns
Fall time of SDA and SCL	t_f		-	300	-	300	ns
STOP condition setup time	$t_{SU,STO}$		4	-	0.6	-	μs
Bus free time between transmissions	t_{BUF}		4.7	-	1.3	-	μs
Capacitive load for each bus line	C_b		-	400	-	400	pF

Table 21 - I²C Slave/Synchronous Slave Interface Timing Definitions

Recommended Operating Conditions

PARAMETER	SYMBOL	CONDITIONS
Operating Temperature	T _A	-20°C to +85°C
AVDD		+3.3V
AVCC_3V3_L		+3.3V
AVCC_3V3_R		+3.3V
AVCC_CP		+3.3V
AVCC_L		Internal
AVCC_R		Internal
DVDD		Internal
PLL_REG		Internal
VREF		Internal
PNEG		Internal

Table 22 - Recommended Operating Conditions

Charge Pump

The ES9081 features an integrated Charge Pump (CP) that produces the internal negative supply required for the “ground centered” line drivers, on pin 18 (PNEG). The CP will automatically shut down, saving power, when a mute condition is detected. This function can be disabled by setting Reg 48[0] CP_MUTE_PD_EN = 1'b0.

The charge pump clock must be set to 705.6kHz or 768kHz depending on the sample rate multiple (44.1kHz/48kHz respectively). This is done by setting the value of CP_CLK_DIV to result in a charge pump clock of 705.1kHz/768kHz. CP_CLK_DIV (default 8d'31) is not required to change when the MCLK rate is 22.5792MHz/24.576MHz or 45.1584MHz/49.152MHz when the MCLK_RATE_SEL register is selected correctly. It will divide the clock automatically according to the equation below. If MCLK is another frequency, then the CP_CLK_DIV must also be set to ensure CP_CLK is in the required range.

$$CP_CLK [Hz] = \frac{MCLK}{2^{\sim MCLK_RATE_SEL} \cdot (CP_CLK_DIV + 1)}$$

$$CP_CLK_DIV = \frac{MCLK}{2^{\sim MCLK_RATE_SEL} \cdot CP_CLK} - 1$$

Charge Pump Registers

- Register 2[7] MCLK_RATE_SEL
- Register 51[7:0] CP_CLK_DIV (Default is 8'd31)
- Register 49[0] CP_MUTE_PD_EN

ES9081 Product Datasheet

Recommended Power Up/Down Sequence

The recommended power up sequence for the ES9081, the AVCC supply is enabled ~200us before AVCC_3V3_L, AVCC_3V3_R, and AVCC_CP are enabled.

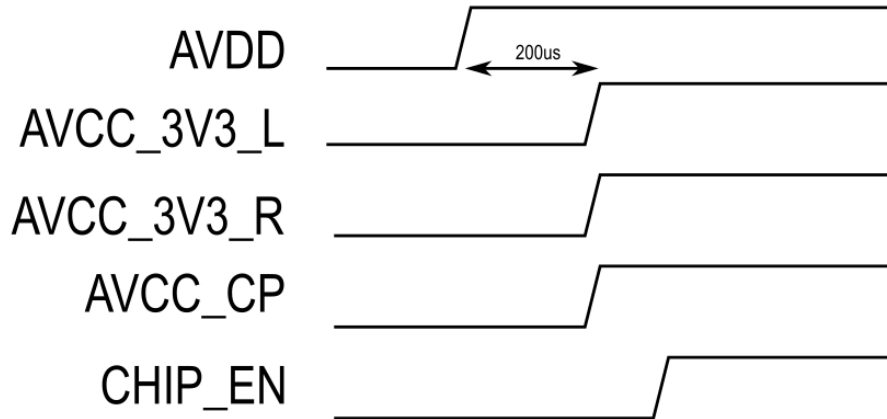

Figure 18 – Recommended Power Up Sequence

On power down, after CHIP_EN is disabled, AVCC_3V3_L, AVCC_3V3_R, AVCC_CP, and AVCC supplies are disabled.

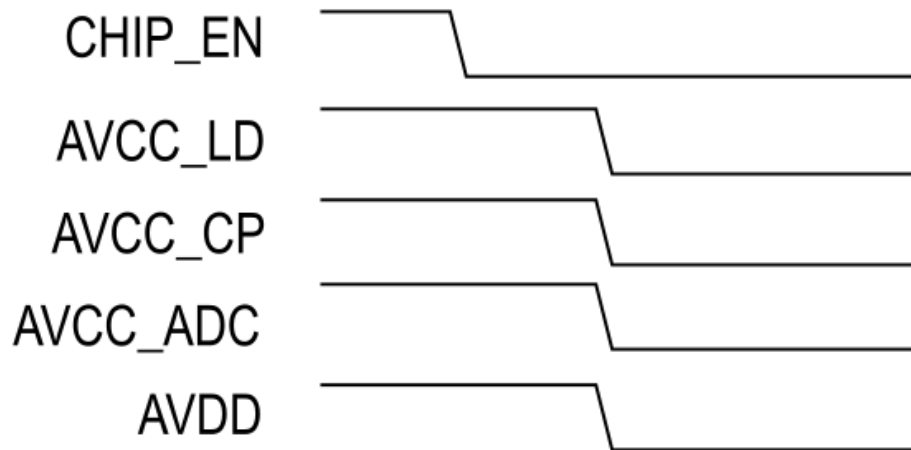

Figure 19 – Recommended Power Down Sequence

Power Consumption

Test Conditions (unless otherwise noted)

$T_A = 25^\circ\text{C}$, AVCC_3V3_L = AVCC_3V3_R = AVCC_CP = AVDD = +3.3V, 0dBFS digital input. AVDD includes DVDD current.

Parameter	Min	Typ.	Max	Unit
Standby (CHIP_EN=0)				
AVCC_3V3_L		<0.1		mA
AVCC_3V3_R		<0.1		mA
AVCC_CP		0		mA
AVDD		<0.1		mA
Fs = 48kHz, MCLK = 24.576MHz				
AVCC_3V3_L		30.9		mA
AVCC_3V3_R		30.9		mA
AVCC_CP		40.5		mA
AVDD		15.9		mA
Fs = 384kHz, MCLK = 24.576MHz				
AVCC_3V3_L		30.9		mA
AVCC_3V3_R		30.9		mA
AVCC_CP		40.5		mA
AVDD		25.5		mA

Table 23 - Power Consumption

ES9081 Product Datasheet

Performance

Test Conditions 1 (unless otherwise noted)

$T_A = 25^\circ\text{C}$, AVCC_3V3_L = AVCC_3V3_R = AVCC_CP = AVDD = +3.3V, $f_s = 48\text{kHz}$, I²S Master Mode

Note: Performance numbers were measured using the ESS ES9081 5v0 evaluation board.

Parameter		Min	Typ.	Max	Unit
Resolution			32		Bit
Max MCLK frequency	Note: Synchronous clocks required		49.152		MHz
THD+N Ratio 0dBFS BW=20Hz-20kHz	8 ch single-ended		-108		dB
	4 ch differential		-110		dB
	4 ch single-ended		-108		dB
DNR (A-weighted) -60dBFS BW=20Hz-20kHz	8 ch single-ended		120		dB
	4 ch differential		124		dB
	4 ch single-ended		123		dB
	2 ch differential		127		dB
	2 ch single-ended		126		dB
Voltage output amplitude	0dBFS Input		2		Vrms

Table 24 - Performance

Register Overview

A system clock is not required to access registers.

Read/Write Register Addresses

Registers 0-135 (0x00 - 0x87) are read and write registers.

Read-Only Register Addresses

Register 224-250 (0xE0 - 0xFA) are read only registers.

Multi-Byte Registers

Multi-Byte registers must be written from LSB to MSB. Data is latched when MSB is written.

Multi-Byte registers must be read from LSB to MSB. Data is latched when LSB is read.

MSB is always stored in the highest register address.



ES9081 Product Datasheet

Register Map

Addr (Hex)	Addr (Dec)	Register	7	6	5	4	3	2	1	0	
0x00	0	SYS CONFIG	SOFT_RESET	RESERVED	I2C_ADDR		AUTO_FS_BLOCK_64FS	AUTO_FS_DETECT	EN_64FS_MODE	ENABLE_DAC	
0x01	1	DIGITAL INPUT CONFIG	ENABLE_PDM_DECODE	ENABLE_DSD_DECODE	ENABLE_DOP_DECODE	ENABLE_TDM_DECODE	RESERVED	INPUT_SEL		AUTO_INPUT_SEL	
0x02	2	CLOCK CONTROL	MCLK_RATE_SEL	MCLK_128FS_HALF_DIV	MCLK_128FS_DIV						
0x03	3	MISC CLOCK CONTROLS	RESERVED					DAC_CLK_INV	EN_CLK_DET	FORCE_PLL_LOCK	
0x04	4	PCM MASTER CLK CONFIG	MASTER_BCK_DIV								
0x05	5	PCM MASTER MODE CONFIG	SLAVE_BCK_INVERT	RESERVED		MASTER_WS_PULSE_MODE	MASTER_WS_INVERT	MASTER_BCK_INVERT	DSD_MASTER_MODE_EN	PCM_MASTER_MODE_EN	
0x06	6	TDM CONFIG 1	TDM_RESYNC	AUTO_CH_DETECT	RESERVED	TDM_CH_NUM					
0x07	7	TDM CONFIG 2	ENABLE_WS_MONITOR	ENABLE_BCK_MONITOR	TDM_WORD_WIDTH		TDM_BIT_DEPTH		TDM_VALID_EDGE	TDM_LJ	
0x08	8	TDM CH1 SLOT CONFIG	RESERVED	TDM_LINE_SEL_CH1		TDM_SLOT_SEL_CH1					
0x09	9	TDM CH2 SLOT CONFIG	RESERVED	TDM_LINE_SEL_CH2		TDM_SLOT_SEL_CH2					
0x0A	10	TDM CH3 SLOT CONFIG	RESERVED	TDM_LINE_SEL_CH3		TDM_SLOT_SEL_CH3					
0x0B	11	TDM CH4 SLOT CONFIG	RESERVED	TDM_LINE_SEL_CH4		TDM_SLOT_SEL_CH4					
0x0C	12	TDM CH5 SLOT CONFIG	RESERVED	TDM_LINE_SEL_CH5		TDM_SLOT_SEL_CH5					
0x0D	13	TDM CH6 SLOT CONFIG	RESERVED	TDM_LINE_SEL_CH6		TDM_SLOT_SEL_CH6					
0x0E	14	TDM CH7 SLOT CONFIG	RESERVED	TDM_LINE_SEL_CH7		TDM_SLOT_SEL_CH7					
0x0F	15	TDM CH8 SLOT CONFIG	RESERVED	TDM_LINE_SEL_CH8		TDM_SLOT_SEL_CH8					
0x10-0x11	16-17	RESERVED	RESERVED								
0x12	18	TDM DAISY CHAIN	TDM_DAISY_CHAIN	TDM_DAISY_CHAIN_LINE_IN		TDM_DATA_LATCH_ADJ					
0x13	19	DSD CH1/2 LINE SELECT	PDM_DATA_PHASE	PDM_FRAME_EDGE	DSD_LINE_SEL_CH2			DSD_LINE_SEL_CH1			
0x14	20	DSD CH3/4 LINE SELECT	RESERVED	PDM_2X_GAIN_EN	DSD_LINE_SEL_CH4			DSD_LINE_SEL_CH3			
0x15	21	DSD CH5/6 LINE SELECT	RESERVED		DSD_LINE_SEL_CH6			DSD_LINE_SEL_CH5			
0x16	22	DSD CH7/8 LINE SELECT	RESERVED		DSD_LINE_SEL_CH8			DSD_LINE_SEL_CH7			
0x17	23	ENCODER CONFIG	RESERVED				SPDIF_CH_PAIR_SEL		ENABLE_SPDIF_ENCODE	RESERVED	
0x18	24	S/PDIF CS ADDR	SPDIF_CS_WE	RESERVED				SPDIF_CS_BYTE_ADDR			
0x19	25	S/PDIF CS DATA	SPDIF_CS_BYTE_DATA								
0x1A-0x23	26-35	RESERVED	RESERVED								
0x24	36	STATUS BITS MASKP 1	VOL_MIN_CH8_MASKP	VOL_MIN_CH7_MASKP	VOL_MIN_CH6_MASKP	VOL_MIN_CH5_MASKP	VOL_MIN_CH4_MASKP	VOL_MIN_CH3_MASKP	VOL_MIN_CH2_MASKP	VOL_MIN_CH1_MASKP	
0x25	37	STATUS BITS MASKP 2	AUTOMUTE_CH8_MASKP	AUTOMUTE_CH7_MASKP	AUTOMUTE_CH6_MASKP	AUTOMUTE_CH5_MASKP	AUTOMUTE_CH4_MASKP	AUTOMUTE_CH3_MASKP	AUTOMUTE_CH2_MASKP	AUTOMUTE_CH1_MASKP	
0x26	38	STATUS BITS MASKP 3	SS_FULL_RAMP_CH8_MASKP	SS_FULL_RAMP_CH7_MASKP	SS_FULL_RAMP_CH6_MASKP	SS_FULL_RAMP_CH5_MASKP	SS_FULL_RAMP_CH4_MASKP	SS_FULL_RAMP_CH3_MASKP	SS_FULL_RAMP_CH2_MASKP	SS_FULL_RAMP_CH1_MASKP	
0x27	39	STATUS BITS MASKP 4	RESERVED	INPUT_SEL_OVR_MASKP		DOP_VALID_CH12_MASKP	TDM_DATA_VALID_MASKP	BCK_WS_FAIL_MASKP	RESERVED	PLL_LOCKED_MASKP	
0x28	40	STATUS BITS MASKN 1	VOL_MIN_CH8_MASKN	VOL_MIN_CH7_MASKN	VOL_MIN_CH6_MASKN	VOL_MIN_CH5_MASKN	VOL_MIN_CH4_MASKN	VOL_MIN_CH3_MASKN	VOL_MIN_CH2_MASKN	VOL_MIN_CH1_MASKN	
0x29	41	STATUS BITS MASKN 2	AUTOMUTE_CH8_MASKN	AUTOMUTE_CH7_MASKN	AUTOMUTE_CH6_MASKN	AUTOMUTE_CH5_MASKN	AUTOMUTE_CH4_MASKN	AUTOMUTE_CH3_MASKN	AUTOMUTE_CH2_MASKN	AUTOMUTE_CH1_MASKN	
0x2A	42	STATUS BITS MASKN 3	SS_FULL_RAMP_CH8_MASKN	SS_FULL_RAMP_CH7_MASKN	SS_FULL_RAMP_CH6_MASKN	SS_FULL_RAMP_CH5_MASKN	SS_FULL_RAMP_CH4_MASKN	SS_FULL_RAMP_CH3_MASKN	SS_FULL_RAMP_CH2_MASKN	SS_FULL_RAMP_CH1_MASKN	
0x2B	43	STATUS BITS MASKN 4	RESERVED	INPUT_SEL_OVR_MASKN		DOP_VALID_CH12_MASKN	TDM_DATA_VALID_MASKN	BCK_WS_FAIL_MASKN	RESERVED	PLL_LOCKED_MASKN	
0x2C	44	STATUS BITS CLEAR 1	VOL_MIN_CH8_CLEAR	VOL_MIN_CH7_CLEAR	VOL_MIN_CH6_CLEAR	VOL_MIN_CH5_CLEAR	VOL_MIN_CH4_CLEAR	VOL_MIN_CH3_CLEAR	VOL_MIN_CH2_CLEAR	VOL_MIN_CH1_CLEAR	
0x2D	45	STATUS BITS CLEAR 2	AUTOMUTE_CH8_CLEAR	AUTOMUTE_CH7_CLEAR	AUTOMUTE_CH6_CLEAR	AUTOMUTE_CH5_CLEAR	AUTOMUTE_CH4_CLEAR	AUTOMUTE_CH3_CLEAR	AUTOMUTE_CH2_CLEAR	AUTOMUTE_CH1_CLEAR	
0x2E	46	STATUS BITS CLEAR 3	SS_FULL_RAMP_CH8_CLEAR	SS_FULL_RAMP_CH7_CLEAR	SS_FULL_RAMP_CH6_CLEAR	SS_FULL_RAMP_CH5_CLEAR	SS_FULL_RAMP_CH4_CLEAR	SS_FULL_RAMP_CH3_CLEAR	SS_FULL_RAMP_CH2_CLEAR	SS_FULL_RAMP_CH1_CLEAR	
0x2F	47	STATUS BITS CLEAR 4	RESERVED	INPUT_SEL_OVR_CLEAR		DOP_VALID_CH12_CLEAR	TDM_DATA_VALID_CLEAR	BCK_WS_FAIL_CLEAR	CLK_AVALID_CLEAR	PLL_LOCKED_CLEAR	
0x30	48	RESERVED	RESERVED								
0x31	49	CHARGE PUMP CONFIG	RESERVED								CP_MUTE_PD_EN
0x32	50	RESERVED	RESERVED								
0x33	51	CHARGE PUMP CLOCK DIV	CP_CLK_DIV								
0x34-0x42	52-66	RESERVED	RESERVED								
0x43	67	GPIO1/2 CONFIG	GPIO2_CFG				GPIO1_CFG				
0x44	68	GPIO3/4 CONFIG	GPIO4_CFG				GPIO3_CFG				
0x45	69	GPIO5/6 CONFIG	GPIO6_CFG				GPIO5_CFG				



ES9081 Product Datasheet

0x46-0x47	70-71	RESERVED	RESERVED								
0x48	72	GPIO INPUT CONTROL	RESERVED		GPIO6_SDB	GPIO5_SDB	GPIO4_SDB	GPIO3_SDB	GPIO2_SDB	GPIO1_SDB	
0x49	73	GPIO OUTPUT CONTROL	GPIO1_AS_DATA8	GPIO_SYSTEM_MODE	RESERVED						
0x4A	74		RESERVED		GPIO6_OE	GPIO5_OE	GPIO4_OE	GPIO3_OE	GPIO2_OE	GPIO1_OE	
0x4B	75	GPIO INVERT CONTROL	GPIO_AND_SS_RAMP	GPIO_AND_AUTOMUTE	GPIO_AND_VOL_MIN	RESERVED					
0x4C	76		RESERVED		GPIO6_INV	GPIO5_INV	GPIO4_INV	GPIO3_INV	GPIO2_INV	GPIO1_INV	
0x4D	77	GPIO KEEPER CONTROL	GPIO_OR_SS_RAMP	GPIO_OR_AUTOMUTE	GPIO_OR_VOL_MIN	RESERVED					
0x4E	78		RESERVED		GPIO6_WK_EN	GPIO5_WK_EN	GPIO4_WK_EN	GPIO3_WK_EN	GPIO2_WK_EN	GPIO1_WK_EN	
0x4F	79	RESERVED	RESERVED								
0x50	80	GPIO READ CONTROL	RESERVED		GPIO6_READ	GPIO5_READ	GPIO4_READ	GPIO3_READ	GPIO2_READ	GPIO1_READ	
0x51	81	RESERVED	RESERVED								
0x52	82	PWM COUNT	PWM_COUNT								
0x53	83	PWM FREQUENCY	PWM_FREQ								
0x54	84		PWM_FREQ								
0x55	85	RESERVED	RESERVED								
0x56	86	DAC FILTER CONFIG	RESERVED		BYPASS_IIR	BYPASS_FIR4X	BYPASS_FIR2X	FILTER_SHAPE			
0x57	87	VOLUME CH1	VOLUME_CH1								
0x58	88	VOLUME CH2	VOLUME_CH2								
0x59	89	VOLUME CH3	VOLUME_CH3								
0x5A	90	VOLUME CH4	VOLUME_CH4								
0x5B	91	VOLUME CH5	VOLUME_CH5								
0x5C	92	VOLUME CH6	VOLUME_CH6								
0x5D	93	VOLUME CH7	VOLUME_CH7								
0x5E	94	VOLUME CH8	VOLUME_CH8								
0x5F	95	PHASE INVERSION	VOL_PHASE_INV_CH8	VOL_PHASE_INV_CH7	VOL_PHASE_INV_CH6	VOL_PHASE_INV_CH5	VOL_PHASE_INV_CH4	VOL_PHASE_INV_CH3	VOL_PHASE_INV_CH2	VOL_PHASE_INV_CH1	
0x60	96	DIGITAL GAIN	RESERVED		DIGITAL_GAIN_CH2			DIGITAL_GAIN_CH1			
0x61	97		RESERVED		DIGITAL_GAIN_CH4			DIGITAL_GAIN_CH3			
0x62	98		RESERVED		DIGITAL_GAIN_CH6			DIGITAL_GAIN_CH5			
0x63	99		RESERVED		DIGITAL_GAIN_CH8			DIGITAL_GAIN_CH7			
0x64	100	MUTE	MUTE_CH8	MUTE_CH7	MUTE_CH6	MUTE_CH5	MUTE_CH4	MUTE_CH3	MUTE_CH2	MUTE_CH1	
0x65	101	SOFT RAMP CONFIG	RESERVED	MONO_VOLUME	MUTE_RAMP_TO_GROUND	SOFT_RAMP_TIME					
0x66	102	VOLUME UP RAMP RATE	VOL_RAMP_RATE_UP								
0x67	103	VOLUME DOWN RAMP RATE	VOL_RAMP_RATE_DOWN								
0x68	104	DC OFFSET	DC_OFFSET								
0x69	105	AUTOMUTE ENABLE	AUTOMUTE_EN_CH8	AUTOMUTE_EN_CH7	AUTOMUTE_EN_CH6	AUTOMUTE_EN_CH5	AUTOMUTE_EN_CH4	AUTOMUTE_EN_CH3	AUTOMUTE_EN_CH2	AUTOMUTE_EN_CH1	
0x6A	106	AUTOMUTE TIME	AUTOMUTE_TIME								
0x6B	107		DSD_FAULT_DETECT_EN	DSD_DC_AM_ENB	DSD_MUTE_AM_ENB	RESERVED			AUTOMUTE_TIME		
0x6C	108		AUTOMUTE LEVEL	AUTOMUTE_LEVEL							
0x6D	109			AUTOMUTE_LEVEL							
0x6E	110	AUTOMUTE OFF LEVEL	AUTOMUTE_OFF_LEVEL								
0x6F	111		AUTOMUTE_OFF_LEVEL								
0x70-0x78	112-120	RESERVED	RESERVED								
0x79	121	PLL CLOCK SELECT	RESERVED	PLL_CLK_PHASE_INV	SEL_PLL_CLK_IN		EN_PLL_CLK_IN	SEL_MCLK_IN		EN_MCLK_IN	
0x7A	122	PLL VCO & CP	RESERVED				PLL_CP_EN	PLL_VCO_EN	PLL_CLKSMP_EN	PLL_DIG_RSTB	
0x7B	123	PLL REGULATOR	RESERVED				PLL_REG_EN	RESERVED			
0x7C	124	PLL FEEDBACK DIV	PLL_CLK_FB_DIV								
0x7D	125		PLL_CLK_FB_DIV								
0x7E	126		PLL_CLK_FB_DIV								
0x7F	127		PLL_CLK_IN_DIV								
0x80	128	PLL IN & OUT DIV	PLL_CLK_OUT_DIV				RESERVED		PLL_FB_DIV_LOAD	PLL_CLK_IN_DIV	
0x81-0xB3	129-179	RESERVED	RESERVED								
0xE0	224	INPUT FORMAT READ	DOP_VALID				DAC_TDM_VALID	INPUT_SEL_OVERRIDE		PLL_LOCKED	
0xE1	225	CHIP ID	CHIP_ID								
0xE2-0xE4	226-228	RESERVED	RESERVED								
0xE5	229	STATUS BITS STATE	VOL_MIN_STATE								
0xE6	230		AUTOMUTE_STATE								
0xE7	231		SS_FULL_RAMP_STATE								
0xE8	232		RESERVED	INPUT_SEL_OVR_STATE		DOP_VALID_CH12_STATE	TDM_DATA_VALID_STATE	BCK_WS_FAIL_STATE	CLK_AVALID_STATE	PLL_LOCKED_STATE	
0xE9	233	RESERVED	RESERVED								
0xEA	234	AUTO FS READ	EN_64FS_MODE_AUTO	MCLK_128FS_HALF_DIV_AUTO	MCLK_128FS_DIV_AUTO						
0xEB	235	CLOCK VALIDITY	RATIO_VALID	BCK_INVALID	WS_INVALID	AUTO_CH_NUM					
0xEC	236	GPIO READBACK	RESERVED		GPIO6_R	GPIO5_R	GPIO4_R	GPIO3_R	GPIO2_R	GPIO1_R	
0xED	237	RESERVED	RESERVED								
0xEE	238	VOL MIN READ	VOL_MIN_CH8	VOL_MIN_CH7	VOL_MIN_CH6	VOL_MIN_CH5	VOL_MIN_CH4	VOL_MIN_CH3	VOL_MIN_CH2	VOL_MIN_CH1	



ES9081 Product Datasheet

0xEF	239	AUTOMUTE READ	AUTOMUTE_ CH8	AUTOMUTE_ CH7	AUTOMUTE_ CH6	AUTOMUTE_ CH5	AUTOMUTE_ CH4	AUTOMUTE_ CH3	AUTOMUTE_ CH2	AUTOMUTE_ CH1
0xF0	240	SOFT RAMP UP READ	SS_RAMP_UP_ CH8	SS_RAMP_UP_ CH7	SS_RAMP_UP_ CH6	SS_RAMP_UP_ CH5	SS_RAMP_UP_ CH4	SS_RAMP_UP_ CH3	SS_RAMP_UP_ CH2	SS_RAMP_UP_ CH1
0xF1	241	SOFT RAMP DOWN READ	SS_RAMP_ DOWN_CH8	SS_RAMP_ DOWN_CH7	SS_RAMP_ DOWN_CH6	SS_RAMP_ DOWN_CH5	SS_RAMP_ DOWN_CH4	SS_RAMP_ DOWN_CH3	SS_RAMP_ DOWN_CH2	SS_RAMP_ DOWN_CH1
0xF2- 0xFA	242- 250	RESERVED	RESERVED							

Register Listing

System Registers

Register 0: SYS CONFIG

Bits	[7]	[6]	[5:4]	[3]	[2]	[1]	[0]
Default	1'b0	1'b0	2'b00	1'b0	1'b1	1'b0	1'b0

Bits	Mnemonic	Description
[7]	SOFT_RESET	Performs soft reset to digital core, resetting all registers to their power-on defaults.
[6]	RESERVED	N/A
[5:4]	I2C_ADDR	Sets the I ² C address of the device. <ul style="list-style-type: none"> • 2'b00: 0x90 (default) • 2'b01: 0x92 • 2'b10: 0x94 • 2'b11: 0x96
[3]	AUTO_FS_BLOCK_64FS	Block AUTO_FS_DETECT from transitioning to 64FS mode when the detected MCLK/MCLK_128FS ratio is 64. <ul style="list-style-type: none"> • 1'b0: Disabled (default) • 1'b1: Enabled
[2]	AUTO_FS_DETECT	Automatically determine optimal (MCLK/MCLK_128FS ratio) according to detected FS. <ul style="list-style-type: none"> • 1'b0: Disabled, use SELECT_MCLK_128FS_NUM to set ratio. • 1'b1: Enabled, overrides SELECT_MCLK_128FS_NUM (default)
[1]	EN_64FS_MODE	Enables 64FS mode for 768k sample rate. <ul style="list-style-type: none"> • 1'b0: Disabled (default) • 1'b1: Enabled
[0]	ENABLE_DAC	Enables the DAC interpolation path. <ul style="list-style-type: none"> • 1'b0: Disabled (default) • 1'b1: Enabled

ES9081 Product Datasheet

Register 1: DIGITAL INPUT CONFIG

Bits	[7]	[6]	[5]	[4]	[3]	[2:1]	[0]
Default	1'b0	1'b0	1'b0	1'b1	1'd0	2'd0	1'b0

Bits	Mnemonic	Description
[7]	ENABLE_PDM_DECODE	Enables PDM decoding. <ul style="list-style-type: none"> 1'b0: Disabled (default) 1'b1: Enabled
[6]	ENABLE_DSD_DECODE	Enables DSD decoding. <ul style="list-style-type: none"> 1'b0: Disabled (default) 1'b1: Enabled
[5]	ENABLE_DOP_DECODE	Enables DoP decoding. <ul style="list-style-type: none"> 1'b0: Disabled (default) 1'b1: Enabled
[4]	ENABLE_TDM_DECODE	Enables I ² S/TDM decoding. <ul style="list-style-type: none"> 1'b0: Disabled 1'b1: Enabled (default)
[3]	RESERVED	N/A
[2:1]	INPUT_SEL	Selects input data format when AUTO_INPUT_SEL is disabled. <ul style="list-style-type: none"> 2'd0: PCM (default) 2'd1: DSD 2'd2: DoP 2'd3: Reserved
[0]	AUTO_INPUT_SEL	Automatic input data selection config. <ul style="list-style-type: none"> 1'b0: Disables auto input select. Input data format is set by INPUT_SEL (default) 1'b1: Automatically determine the input data format.

Register 2: CLOCK CONTROL

Bits	[7]	[6]	[5:0]
Default	1'b0	1'b0	6'd3

Bits	Mnemonic	Description
[7]	MCLK_RATE_SEL	Sets the frequency of MCLK, allowing controls to automatically scale between MCLK rates. <ul style="list-style-type: none"> 1'b0: MCLK = 22.5792MHz / 24.576MHz (default) 1'b1: MCLK = 45.1584MHz / 49.152MHz
[6]	MCLK_128FS_HALF_DIV	<ul style="list-style-type: none"> 1'b0: Divide by MCLK_128FS_DIV + 1 (default) 1'b1: Divide by half of MCLK_128FS_DIV + 1 Note: Can only produce half of an odd number divide
[5:0]	MCLK_128FS_DIV	Whole number divide value + 1 for MCLK_128FS (MCLK/divide_value). <ul style="list-style-type: none"> 6'd0: Whole number divide value + 1 = 1 6'd3: Whole number divide value + 1 = 4 (default)

Register 3: MISC CLOCK CONTROLS

Bits	[7:3]	[2]	[1]	[0]
Default	5'd0	1'b0	1'b0	1'b0

Bits	Mnemonic	Description
[7:3]	RESERVED	N/A
[2]	DAC_CLK_INV	Inverts the phase of the analog DAC_CLK. <ul style="list-style-type: none"> 1'b0: Non-inverted (default) 1'b1: Inverted
[1]	EN_CLK_DET	Enable Clock Detection circuit <ul style="list-style-type: none"> 1'b0: Disabled (default) 1'b1: Enabled
[0]	FORCE_PLL_LOCK	Clock locking status control with PLL_LOCKED. <ul style="list-style-type: none"> 1'b0: clock locking status is determined by PLL_LOCKED 1'b1: ignores PLL_LOCKED signal from PLL and sets clock locking status to 1'b1

Register 4: PCM MASTER CLK CONFIG

Bits	[7:0]
Default	8'd7

Bits	Mnemonic	Description
[7:0]	MASTER_BCK_DIV	Master mode DCLK and WS generation clock divider. Whole number divide value + 1 for CLK_BCK_WS_GEN (MCLK/divide_value).

ES9081 Product Datasheet

Register 5: PCM MASTER MODE CONFIG

Bits	[7]	[6:5]	[4]	[3]	[2]	[1]	[0]
Default	1'b0	2'b01	1'b0	1'b0	1'b1	1'b0	1'b0

Bits	Mnemonic	Description
[7]	SLAVE_BCK_INVERT	<ul style="list-style-type: none"> 1'b0: Non-inverted (default) 1'b1: Invert BCK input
[6:5]	RESERVED	N/A
[4]	MASTER_WS_PULSE_MODE	When enabled, master WS is a 1 BCK pulse signal instead of a 50% duty cycle signal. <ul style="list-style-type: none"> 1'b0: 50% duty cycle WS signal (default) 1'b1: Pulse WS signal
[3]	MASTER_WS_INVERT	Inverts master WS. <ul style="list-style-type: none"> 1'b0: Non-inverted (default) 1'b1: Inverted
[2]	MASTER_BCK_INVERT	Inverts master BCK. <ul style="list-style-type: none"> 1'b0: Non-inverted 1'b1: Inverted (default)
[1]	DSD_MASTER_MODE_EN	Enables DSD master mode, generating DATA_CLK. <ul style="list-style-type: none"> 1'b0: Disabled, slave mode (default) 1'b1: Enabled
[0]	PCM_MASTER_MODE_EN	Enables PCM master mode, generating BCK and WS. <ul style="list-style-type: none"> 1'b0: Disabled, slave mode (default) 1'b1: Enabled

Register 6: TDM CONFIG 1

Bits	[7]	[6]	[5]	[4:0]
Default	1'b0	1'b0	1'b0	5'd1

Bits	Mnemonic	Description
[7]	TDM_RESYNC	Force TDM encoder & decoder to resync. <ul style="list-style-type: none"> 1'b0: Enable TDM codec synchronization (default) 1'b1: Force TDM codec to desynchronize.
[6]	AUTO_CH_DETECT	<ul style="list-style-type: none"> 1'b0: Disabled (default) 1'b1: Auto detect BCK/FRAME ratio to determine the number of TDM channels Note: Only active in TDM slave mode.
[5]	RESERVED	N/A
[4:0]	TDM_CH_NUM	Sets number of channels in each frame. <ul style="list-style-type: none"> 5'd0: 1 channel 5'd1: 2 channels (default) 5'd31: 32 channels

Register 7: TDM CONFIG 2

Bits	[7]	[6]	[5:4]	[3:2]	[1]	[0]
Default	1'b1	1'b1	2'b00	2'b00	1'b0	1'b0

Bits	Mnemonic	Description
[7]	ENABLE_WS_MONITOR	Enable WS monitor, used to detect the validity of the WS signal. WS is considered invalid if BCK/WS > 1024. <ul style="list-style-type: none"> 1'b0: Disabled 1'b1: Enabled (default)
[6]	ENABLE_BCK_MONITOR	Enable BCK monitor, used to detect the validity of the BCK signal. BCK is considered invalid if MCLK/BCK > 256. <ul style="list-style-type: none"> 1'b0: Disabled 1'b1: Enabled (default)
[5:4]	TDM_WORD_WIDTH	Sets the width, in bits, of one data word / subframe. A subframe is a frame divided by the number of channels. <ul style="list-style-type: none"> 2'b00: 32-bits (default) 2'b01: 24-bits 2'b10: 16-bits
[3:2]	TDM_BIT_DEPTH	Sets the bit depth, number of data bits, in one data word / subframe. <ul style="list-style-type: none"> 2'b00: 32-bit (default) 2'b01: 24-bit 2'b10: 16-bit
[1]	TDM_VALID_EDGE	Sets which WS edge the frame starts on. <ul style="list-style-type: none"> 1'b0: Frame starts on negedge of WS (default) 1'b1: Frame starts on posedge of WS
[0]	TDM_LJ	Sets left-justified mode. <ul style="list-style-type: none"> 1'b0: One BCK period delay (default) 1'b1: Left-justified

ES9081 Product Datasheet

Register 8: TDM CH1 SLOT CONFIG

Bits	[7]	[6:5]	[4:0]
Default	1'd0	2'd0	5'd0

Bits	Mnemonic	Description
[7]	RESERVED	N/A
[6:5]	TDM_LINE_SEL_CH1	CH1 data line selection. CH1 receives the data from: <ul style="list-style-type: none"> 2'd0: DATA2 (default) 2'd1: DATA3/GPIO2 2'd2: DATA4/GPIO3 2'd3: DATA5/GPIO4
[4:0]	TDM_SLOT_SEL_CH1	Selects which TDM channel slot is latched into CH1. <ul style="list-style-type: none"> 5'd0: Slot 1 (default) 5'd31: Slot 32

Register 9: TDM CH2 SLOT CONFIG

Bits	[7]	[6:5]	[4:0]
Default	1'd0	2'd0	5'd1

Bits	Mnemonic	Description
[7]	RESERVED	N/A
[6:5]	TDM_LINE_SEL_CH2	CH2 data line selection. CH2 receives the data from: <ul style="list-style-type: none"> 2'd0: DATA2 (default) 2'd1: DATA3/GPIO2 2'd2: DATA4/GPIO3 2'd3: DATA5/GPIO4
[4:0]	TDM_SLOT_SEL_CH2	Selects which TDM channel slot is latched into CH2. <ul style="list-style-type: none"> 5'd0: Slot 1 5'd1: Slot 2 (default) 5'd31: Slot 32

Register 10: TDM CH3 SLOT CONFIG

Bits	[7]	[6:5]	[4:0]
Default	1'd0	2'd1	5'd0

Bits	Mnemonic	Description
[7]	RESERVED	N/A
[6:5]	TDM_LINE_SEL_CH3	CH3 data line selection. CH3 receives the data from: <ul style="list-style-type: none"> • 2'd0: DATA2 • 2'd1: DATA3/GPIO2 (default) • 2'd2: DATA4/GPIO3 • 2'd3: DATA5/GPIO4
[4:0]	TDM_SLOT_SEL_CH3	Selects which TDM channel slot is latched into CH3. <ul style="list-style-type: none"> • 5'd0: Slot 1 (default) • 5'd31: Slot 32

Register 11: TDM CH4 SLOT CONFIG

Bits	[7]	[6:5]	[4:0]
Default	1'd0	2'd1	5'd1

Bits	Mnemonic	Description
[7]	RESERVED	N/A
[6:5]	TDM_LINE_SEL_CH4	CH4 data line selection. CH4 receives the data from: <ul style="list-style-type: none"> • 2'd0: DATA2 • 2'd1: DATA3/GPIO2 (default) • 2'd2: DATA4/GPIO3 • 2'd3: DATA5/GPIO4
[4:0]	TDM_SLOT_SEL_CH4	Selects which TDM channel slot is latched into CH4. <ul style="list-style-type: none"> • 5'd0: Slot 1 • 5'd1: Slot 2 (default) • 5'd31: Slot 32

ES9081 Product Datasheet

Register 12: TDM CH5 SLOT CONFIG

Bits	[7]	[6:5]	[4:0]
Default	1'd0	2'd2	5'd0

Bits	Mnemonic	Description
[7]	RESERVED	N/A
[6:5]	TDM_LINE_SEL_CH5	CH5 data line selection. CH5 receives the data from: <ul style="list-style-type: none"> 2'd0: DATA2 2'd1: DATA3/GPIO2 2'd2: DATA4/GPIO3 (default) 2'd3: DATA5/GPIO4
[4:0]	TDM_SLOT_SEL_CH5	Selects which TDM channel slot is latched into CH5. <ul style="list-style-type: none"> 5'd0: Slot 1 (default) 5'd31: Slot 32

Register 13: TDM CH6 SLOT CONFIG

Bits	[7]	[6:5]	[4:0]
Default	1'd0	2'd2	5'd1

Bits	Mnemonic	Description
[7]	RESERVED	N/A
[6:5]	TDM_LINE_SEL_CH6	CH6 data line selection. CH6 receives the data from: <ul style="list-style-type: none"> 2'd0: DATA2 2'd1: DATA3/GPIO2 2'd2: DATA4/GPIO3 (default) 2'd3: DATA5/GPIO4
[4:0]	TDM_SLOT_SEL_CH6	Selects which TDM channel slot is latched into CH6. <ul style="list-style-type: none"> 5'd0: Slot 1 5'd1: Slot 2 (default) 5'd31: Slot 32

Register 14: TDM CH7 SLOT CONFIG

Bits	[7]	[6:5]	[4:0]
Default	1'd0	2'd3	5'd0

Bits	Mnemonic	Description
[7]	RESERVED	N/A
[6:5]	TDM_LINE_SEL_CH7	CH7 data line selection. CH7 receives the data from: <ul style="list-style-type: none"> • 2'd0: DATA2 • 2'd1: DATA3/GPIO2 • 2'd2: DATA4/GPIO3 • 2'd3: DATA5/GPIO4 (default)
[4:0]	TDM_SLOT_SEL_CH7	Selects which TDM channel slot is latched into CH7. <ul style="list-style-type: none"> • 5'd0: Slot 1 (default) • 5'd31: Slot 32

Register 15: TDM CH8 SLOT CONFIG

Bits	[7]	[6:5]	[4:0]
Default	1'd0	2'd3	5'd1

Bits	Mnemonic	Description
[7]	RESERVED	N/A
[6:5]	TDM_LINE_SEL_CH8	CH8 data line selection. CH8 receives the data from: <ul style="list-style-type: none"> • 2'd0: DATA2 • 2'd1: DATA3/GPIO2 • 2'd2: DATA4/GPIO3 • 2'd3: DATA5/GPIO4 (default)
[4:0]	TDM_SLOT_SEL_CH8	Selects which TDM channel slot is latched into CH8. <ul style="list-style-type: none"> • 5'd0: Slot 1 • 5'd1: Slot 2 (default) • 5'd31: Slot 32

ES9081 Product Datasheet

Register 17-16: RESERVED

Register 18: TDM DAISY CHAIN

Bits	[7]	[6:5]	[4:0]
Default	1'b0	2'd0	5'd0

Bits	Mnemonic	Description
[7]	TDM_DAISY_CHAIN	DAC TDM daisy chain mode. <ul style="list-style-type: none"> 1'b0: Disabled (default) 1'b1: Enabled
[6:5]	TDM_DAISY_CHAIN_LINE_IN	Daisy chain input data line selection, chains the data from: <ul style="list-style-type: none"> 2'd0: DATA2 (default) 2'd1: DATA3/GPIO2 2'd2: DATA4/GPIO3 2'd3: DATA5/GPIO4
[4:0]	TDM_DATA_LATCH_ADJ	Adjusts the position of the MSB within each TDM slot by TDM_DATA_LATCH_ADJ clock cycles. <ul style="list-style-type: none"> 5'd0: Normal position 5'd1-31: Number of clock cycles to wait

Register 19: DSD CH1/2 LINE SELECT

Bits	[7]	[6]	[5:3]	[2:0]
Default	1'b0	1'b1	3'd1	3'd0

Bits	Mnemonic	Description
[7]	PDM_PHASE	<ul style="list-style-type: none"> 1'b0: CH1 on the rising edge of PDM clock, CH2 on the falling edge (default) 1'b1: CH2 on the rising edge of PDM clock, CH1 on the falling edge
[6]	PDM_SAMPLE_EDGE	Sets the edge of PDM_CLK where the PDM sample increments. <ul style="list-style-type: none"> 1'b0: Rising edge 1'b1: Falling edge (default)
[5:3]	DSD_LINE_SEL_CH2	Selects the source for the CH2 DSD data. <ul style="list-style-type: none"> 3'd0: DATA1 3'd1: DATA2 (default) 3'd2: DATA3/GPIO2 3'd3: DATA4/GPIO3 3'd4: DATA5/GPIO4 3'd5: DATA6/GPIO5 3'd6: DATA7/GPIO6 3'd7: DATA8/GPIO1/MCLK Note: In order to use DATA8 the device must be running in PLL mode to free up the MCLK pin.
[2:0]	DSD_LINE_SEL_CH1	Selects the source for the CH1 DSD data. <ul style="list-style-type: none"> 3'd0: DATA1 (default) 3'd1: DATA2 3'd2: DATA3/GPIO2 3'd3: DATA4/GPIO3 3'd4: DATA5/GPIO4 3'd5: DATA6/GPIO5 3'd6: DATA7/GPIO6 3'd7: DATA8/GPIO1/MCLK Note: In order to use DATA8 the device must be running in PLL mode to free up the MCLK pin.

ES9081 Product Datasheet

Register 20: DSD CH3/4 LINE SELECT

Bits	[7]	[6]	[5:3]	[2:0]
Default	1'd0	1'b0	3'd3	3'd2

Bits	Mnemonic	Description
[7]	RESERVED	N/A
[6]	PDM_2X_GAIN_EN	Sets the overall gain of the PDM datapath. <ul style="list-style-type: none"> 1'b0: 1x gain (default) 1'b1: 2x gain
[5:3]	DSD_LINE_SEL_CH4	Selects the source for the CH4 DSD data. <ul style="list-style-type: none"> 3'd0: DATA1 3'd1: DATA2 3'd2: DATA3/GPIO2 3'd3: DATA4/GPIO3 (default) 3'd4: DATA5/GPIO4 3'd5: DATA6/GPIO5 3'd6: DATA7/GPIO6 3'd7: DATA8/GPIO1/MCLK Note: In order to use DATA8 the device must be running in PLL mode to free up the MCLK pin.
[2:0]	DSD_LINE_SEL_CH3	Selects the source for the CH3 DSD data. <ul style="list-style-type: none"> 3'd0: DATA1 3'd1: DATA2 3'd2: DATA3/GPIO2 (default) 3'd3: DATA4/GPIO3 3'd4: DATA5/GPIO4 3'd5: DATA6/GPIO5 3'd6: DATA7/GPIO6 3'd7: DATA8/GPIO1/MCLK Note: In order to use DATA8 the device must be running in PLL mode to free up the MCLK pin.

Register 21: DSD CH5/6 LINE SELECT

Bits	[7:6]	[5:3]	[2:0]
Default	2'd0	3'd5	3'd4

Bits	Mnemonic	Description
[7:6]	RESERVED	N/A
[5:3]	DSD_LINE_SEL_CH6	Selects the source for the CH6 DSD data. <ul style="list-style-type: none"> • 3'd0: DATA1 • 3'd1: DATA2 • 3'd2: DATA3/GPIO2 • 3'd3: DATA4/GPIO3 • 3'd4: DATA5/GPIO4 • 3'd5: DATA6/GPIO5 (default) • 3'd6: DATA7/GPIO6 • 3'd7: DATA8/GPIO1/MCLK Note: In order to use DATA8 the device must be running in PLL mode to free up the MCLK pin.
[2:0]	DSD_LINE_SEL_CH5	Selects the source for the CH5 DSD data. <ul style="list-style-type: none"> • 3'd0: DATA1 • 3'd1: DATA2 • 3'd2: DATA3/GPIO2 • 3'd3: DATA4/GPIO3 • 3'd4: DATA5/GPIO4 (default) • 3'd5: DATA6/GPIO5 • 3'd6: DATA7/GPIO6 • 3'd7: DATA8/GPIO1/MCLK Note: In order to use DATA8 the device must be running in PLL mode to free up the MCLK pin.

ES9081 Product Datasheet

Register 22: DSD CH7/8 LINE SELECT

Bits	[7:6]	[5:3]	[2:0]
Default	2'd0	3'd7	3'd6

Bits	Mnemonic	Description
[7:6]	RESERVED	N/A
[5:3]	DSD_LINE_SEL_CH8	<p>Selects the source for the CH8 DSD data.</p> <ul style="list-style-type: none"> 3'd0: DATA1 3'd1: DATA2 3'd2: DATA3/GPIO2 3'd3: DATA4/GPIO3 3'd4: DATA5/GPIO4 3'd5: DATA6/GPIO5 3'd6: DATA7/GPIO6 3'd7: DATA8/GPIO1/MCLK (default) <p>Note: In order to use DATA8 the device must be running in PLL mode to free up the MCLK pin.</p>
[2:0]	DSD_LINE_SEL_CH7	<p>Selects the source for the CH7 DSD data.</p> <ul style="list-style-type: none"> 3'd0: DATA1 3'd1: DATA2 3'd2: DATA3/GPIO2 3'd3: DATA4/GPIO3 3'd4: DATA5/GPIO4 3'd5: DATA6/GPIO5 3'd6: DATA7/GPIO6 (default) 3'd7: DATA8/GPIO1/MCLK <p>Note: In order to use DATA8 the device must be running in PLL mode to free up the MCLK pin.</p>

Register 23: ENCODER CONFIG

Bits	[7:4]	[3:2]	[1]	[0]
Default	4'b0000	2'b00	1'b0	1'b0

Bits	Mnemonic	Description
[7:4]	RESERVED	N/A
[3:2]	SPDIF_CH_PAIR_SEL	<p>Selects the channel pair sent to the S/PDIF encoder.</p> <ul style="list-style-type: none"> 2'b00: CH1/2 (default) 2'b01: CH3/4 2'b10: CH5/6 2'b11: CH7/8
[1]	ENABLE_SPDIF_ENCODE	<p>Enables the S/PDIF encoder.</p> <ul style="list-style-type: none"> 1'b0: Disabled (default) 1'b1: Enabled
[0]	RESERVED	N/A

Register 24: S/PDIF CS ADDR

Bits	[7]	[6:3]	[2:0]
Default	1'b0	4'd0	3'd0

Bits	Mnemonic	Description
[7]	SPDIF_CS_WE	Write enable for the S/PDIF channel status bits. Writes the SPDIF_CS_DATA to the byte at address SPDIF_CS_BYTE_SEL. Toggle high-low to perform a write.
[6:3]	RESERVED	N/A
[2:0]	SPDIF_CS_BYTE_ADDR	Byte of the 40-bit S/PDIF Channel Status register to write to.

Register 25: S/PDIF CS DATA

Bits	[7:0]
Default	8'h00

Bits	Mnemonic	Description
[7:0]	SPDIF_CS_BYTE_DATA	Data to write into the 40-bit S/PDIF Channel Status register.

Register 35-26: RESERVED
Register 36: STATUS BITS MASKP 1

Bits	[7]	[6]	[5]	[4]	[3]	[2]	[1]	[0]
Default	1'b0	1'b0	1'b0	1'b0	1'b0	1'b0	1'b0	1'b0

Bits	Mnemonic	Description
[7]	VOL_MIN_CH8_MASKP	Masks negative to positive transitions of the CH8 "Minimum Volume" flag.
[6]	VOL_MIN_CH7_MASKP	Masks negative to positive transitions of the CH7 "Minimum Volume" flag.
[5]	VOL_MIN_CH6_MASKP	Masks negative to positive transitions of the CH6 "Minimum Volume" flag.
[4]	VOL_MIN_CH5_MASKP	Masks negative to positive transitions of the CH5 "Minimum Volume" flag.
[3]	VOL_MIN_CH4_MASKP	Masks negative to positive transitions of the CH4 "Minimum Volume" flag.
[2]	VOL_MIN_CH3_MASKP	Masks negative to positive transitions of the CH3 "Minimum Volume" flag.
[1]	VOL_MIN_CH2_MASKP	Masks negative to positive transitions of the CH2 "Minimum Volume" flag.
[0]	VOL_MIN_CH1_MASKP	Masks negative to positive transitions of the CH1 "Minimum Volume" flag.

ES9081 Product Datasheet

Register 37: STATUS BITS MASKP 2

Bits	[7]	[6]	[5]	[4]	[3]	[2]	[1]	[0]
Default	1'b0	1'b0	1'b0	1'b0	1'b0	1'b0	1'b0	1'b0

Bits	Mnemonic	Description
[7]	AUTOMUTE_CH8_MASKP	Masks negative to positive transitions of the CH8 "Automute Status" flag.
[6]	AUTOMUTE_CH7_MASKP	Masks negative to positive transitions of the CH7 "Automute Status" flag.
[5]	AUTOMUTE_CH6_MASKP	Masks negative to positive transitions of the CH6 "Automute Status" flag.
[4]	AUTOMUTE_CH5_MASKP	Masks negative to positive transitions of the CH5 "Automute Status" flag.
[3]	AUTOMUTE_CH4_MASKP	Masks negative to positive transitions of the CH4 "Automute Status" flag.
[2]	AUTOMUTE_CH3_MASKP	Masks negative to positive transitions of the CH3 "Automute Status" flag.
[1]	AUTOMUTE_CH2_MASKP	Masks negative to positive transitions of the CH2 "Automute Status" flag.
[0]	AUTOMUTE_CH1_MASKP	Masks negative to positive transitions of the CH1 "Automute Status" flag.

Register 38: STATUS BITS MASKP 3

Bits	[7]	[6]	[5]	[4]	[3]	[2]	[1]	[0]
Default	1'b0	1'b0	1'b0	1'b0	1'b0	1'b0	1'b0	1'b0

Bits	Mnemonic	Description
[7]	SS_FULL_RAMP_CH8_MASKP	Masks negative to positive transitions of the CH8 "Soft Ramp Done" flag.
[6]	SS_FULL_RAMP_CH7_MASKP	Masks negative to positive transitions of the CH7 "Soft Ramp Done" flag.
[5]	SS_FULL_RAMP_CH6_MASKP	Masks negative to positive transitions of the CH6 "Soft Ramp Done" flag.
[4]	SS_FULL_RAMP_CH5_MASKP	Masks negative to positive transitions of the CH5 "Soft Ramp Done" flag.
[3]	SS_FULL_RAMP_CH4_MASKP	Masks negative to positive transitions of the CH4 "Soft Ramp Done" flag.
[2]	SS_FULL_RAMP_CH3_MASKP	Masks negative to positive transitions of the CH3 "Soft Ramp Done" flag.
[1]	SS_FULL_RAMP_CH2_MASKP	Masks negative to positive transitions of the CH2 "Soft Ramp Done" flag.
[0]	SS_FULL_RAMP_CH1_MASKP	Masks negative to positive transitions of the CH1 "Soft Ramp Done" flag.

Register 39: STATUS BITS MASKP 4

Bits	[7]	[6:5]	[4]	[3]	[2]	[1]	[0]
Default	1'd0	2'b00	1'b0	1'b0	1'b0	1'b0	1'b0

Bits	Mnemonic	Description
[7]	RESERVED	N/A
[6:5]	INPUT_SEL_OVR_MASKP	Masks negative to positive transitions of either bit of the "INPUT_SEL_OVERRIDE" flag.
[4]	DOP_VALID_CH12_MASKP	Masks negative to positive transitions of CH1/2 channel pair "DOP_VALID" flag.
[3]	TDM_DATA_VALID_MASKP	Masks negative to positive transitions of the "TDM_DATA_VALID" flag.
[2]	BCK_WS_FAIL_MASKP	Masks negative to positive transitions of the "BCK_WS_FAIL" flag.
[1]	RESERVED	N/A
[0]	PLL_LOCKED_MASKP	Masks negative to positive transitions of the "PLL_LOCKED" flag.

Register 40: STATUS BITS MASKN 1

Bits	[7]	[6]	[5]	[4]	[3]	[2]	[1]	[0]
Default	1'b0	1'b0	1'b0	1'b0	1'b0	1'b0	1'b0	1'b0

Bits	Mnemonic	Description
[7]	VOL_MIN_CH8_MASKN	Masks positive to negative transitions of the CH8 "Minimum Volume" flag.
[6]	VOL_MIN_CH7_MASKN	Masks positive to negative transitions of the CH7 "Minimum Volume" flag.
[5]	VOL_MIN_CH6_MASKN	Masks positive to negative transitions of the CH6 "Minimum Volume" flag.
[4]	VOL_MIN_CH5_MASKN	Masks positive to negative transitions of the CH5 "Minimum Volume" flag.
[3]	VOL_MIN_CH4_MASKN	Masks positive to negative transitions of the CH4 "Minimum Volume" flag.
[2]	VOL_MIN_CH3_MASKN	Masks positive to negative transitions of the CH3 "Minimum Volume" flag.
[1]	VOL_MIN_CH2_MASKN	Masks positive to negative transitions of the CH2 "Minimum Volume" flag.
[0]	VOL_MIN_CH1_MASKN	Masks positive to negative transitions of the CH1 "Minimum Volume" flag.

ES9081 Product Datasheet

Register 41: STATUS BITS MASKN 2

Bits	[7]	[6]	[5]	[4]	[3]	[2]	[1]	[0]
Default	1'b0	1'b0	1'b0	1'b0	1'b0	1'b0	1'b0	1'b0

Bits	Mnemonic	Description
[7]	AUTOMUTE_CH8_MASKN	Masks positive to negative transitions of the CH8 "Automute Status" flag.
[6]	AUTOMUTE_CH7_MASKN	Masks positive to negative transitions of the CH7 "Automute Status" flag.
[5]	AUTOMUTE_CH6_MASKN	Masks positive to negative transitions of the CH6 "Automute Status" flag.
[4]	AUTOMUTE_CH5_MASKN	Masks positive to negative transitions of the CH5 "Automute Status" flag.
[3]	AUTOMUTE_CH4_MASKN	Masks positive to negative transitions of the CH4 "Automute Status" flag.
[2]	AUTOMUTE_CH3_MASKN	Masks positive to negative transitions of the CH3 "Automute Status" flag.
[1]	AUTOMUTE_CH2_MASKN	Masks positive to negative transitions of the CH2 "Automute Status" flag.
[0]	AUTOMUTE_CH1_MASKN	Masks positive to negative transitions of the CH1 "Automute Status" flag.

Register 42: STATUS BITS MASKN 3

Bits	[7]	[6]	[5]	[4]	[3]	[2]	[1]	[0]
Default	1'b0	1'b0	1'b0	1'b0	1'b0	1'b0	1'b0	1'b0

Bits	Mnemonic	Description
[7]	SS_FULL_RAMP_CH8_MASKN	Masks positive to negative transitions of the CH8 "Soft Ramp Done" flag.
[6]	SS_FULL_RAMP_CH7_MASKN	Masks positive to negative transitions of the CH7 "Soft Ramp Done" flag.
[5]	SS_FULL_RAMP_CH6_MASKN	Masks positive to negative transitions of the CH6 "Soft Ramp Done" flag.
[4]	SS_FULL_RAMP_CH5_MASKN	Masks positive to negative transitions of the CH5 "Soft Ramp Done" flag.
[3]	SS_FULL_RAMP_CH4_MASKN	Masks positive to negative transitions of the CH4 "Soft Ramp Done" flag.
[2]	SS_FULL_RAMP_CH3_MASKN	Masks positive to negative transitions of the CH3 "Soft Ramp Done" flag.
[1]	SS_FULL_RAMP_CH2_MASKN	Masks positive to negative transitions of the CH2 "Soft Ramp Done" flag.
[0]	SS_FULL_RAMP_CH1_MASKN	Masks positive to negative transitions of the CH1 "Soft Ramp Done" flag.

Register 43: STATUS BITS MASKN 4

Bits	[7]	[6:5]	[4]	[3]	[2]	[1]	[0]
Default	1'd0	2'b00	1'b0	1'b0	1'b0	1'b0	1'b0

Bits	Mnemonic	Description
[7]	RESERVED	N/A
[6:5]	INPUT_SEL_OVR_MASKN	Masks positive to negative transitions of either bit of the "INPUT_SEL_OVERRIDE" flag.
[4]	DOP_VALID_CH12_MASKN	Masks positive to negative transitions of CH1/2 channel pair "DOP_VALID" flag.
[3]	TDM_DATA_VALID_MASKN	Masks positive to negative transitions of the "TDM_DATA_VALID" flag.
[2]	BCK_WS_FAIL_MASKN	Masks positive to negative transitions of the "BCK_WS_FAIL" flag.
[1]	RESERVED	N/A
[0]	PLL_LOCKED_MASKN	Masks positive to negative transitions of the "PLL_LOCKED" flag.

Register 44: STATUS BITS CLEAR 1

Bits	[7]	[6]	[5]	[4]	[3]	[2]	[1]	[0]
Default	1'b0	1'b0	1'b0	1'b0	1'b0	1'b0	1'b0	1'b0

Bits	Mnemonic	Description
[7]	VOL_MIN_CH8_CLEAR	Toggle high-low to clear and re-arm status bit.
[6]	VOL_MIN_CH7_CLEAR	Toggle high-low to clear and re-arm status bit.
[5]	VOL_MIN_CH6_CLEAR	Toggle high-low to clear and re-arm status bit.
[4]	VOL_MIN_CH5_CLEAR	Toggle high-low to clear and re-arm status bit.
[3]	VOL_MIN_CH4_CLEAR	Toggle high-low to clear and re-arm status bit.
[2]	VOL_MIN_CH3_CLEAR	Toggle high-low to clear and re-arm status bit.
[1]	VOL_MIN_CH2_CLEAR	Toggle high-low to clear and re-arm status bit.
[0]	VOL_MIN_CH1_CLEAR	Toggle high-low to clear and re-arm status bit.

ES9081 Product Datasheet

Register 45: STATUS BITS CLEAR 2

Bits	[7]	[6]	[5]	[4]	[3]	[2]	[1]	[0]
Default	1'b0	1'b0	1'b0	1'b0	1'b0	1'b0	1'b0	1'b0

Bits	Mnemonic	Description
[7]	AUTOMUTE_CH8_CLEAR	Toggle high-low to clear and re-arm status bit.
[6]	AUTOMUTE_CH7_CLEAR	Toggle high-low to clear and re-arm status bit.
[5]	AUTOMUTE_CH6_CLEAR	Toggle high-low to clear and re-arm status bit.
[4]	AUTOMUTE_CH5_CLEAR	Toggle high-low to clear and re-arm status bit.
[3]	AUTOMUTE_CH4_CLEAR	Toggle high-low to clear and re-arm status bit.
[2]	AUTOMUTE_CH3_CLEAR	Toggle high-low to clear and re-arm status bit.
[1]	AUTOMUTE_CH2_CLEAR	Toggle high-low to clear and re-arm status bit.
[0]	AUTOMUTE_CH1_CLEAR	Toggle high-low to clear and re-arm status bit.

Register 46: STATUS BITS CLEAR 3

Bits	[7]	[6]	[5]	[4]	[3]	[2]	[1]	[0]
Default	1'b0	1'b0	1'b0	1'b0	1'b0	1'b0	1'b0	1'b0

Bits	Mnemonic	Description
[7]	SS_FULL_RAMP_CH8_CLEAR	Toggle high-low to clear and re-arm status bit.
[6]	SS_FULL_RAMP_CH7_CLEAR	Toggle high-low to clear and re-arm status bit.
[5]	SS_FULL_RAMP_CH6_CLEAR	Toggle high-low to clear and re-arm status bit.
[4]	SS_FULL_RAMP_CH5_CLEAR	Toggle high-low to clear and re-arm status bit.
[3]	SS_FULL_RAMP_CH4_CLEAR	Toggle high-low to clear and re-arm status bit.
[2]	SS_FULL_RAMP_CH3_CLEAR	Toggle high-low to clear and re-arm status bit.
[1]	SS_FULL_RAMP_CH2_CLEAR	Toggle high-low to clear and re-arm status bit.
[0]	SS_FULL_RAMP_CH1_CLEAR	Toggle high-low to clear and re-arm status bit.

Register 47: STATUS BITS CLEAR 4

Bits	[7]	[6:5]	[4]	[3]	[2]	[1]	[0]
Default	1'd0	2'b00	1'b0	1'b0	1'b0	1'b0	1'b0

Bits	Mnemonic	Description
[7]	RESERVED	N/A
[6:5]	INPUT_SEL_OVR_CLEAR	Toggle high-low to clear and re-arm status bit.
[4]	DOP_VALID_CH12_CLEAR	Toggle high-low to clear and re-arm status bit.
[3]	TDM_DATA_VALID_CLEAR	Toggle high-low to clear and re-arm status bit.
[2]	BCK_WS_FAIL_CLEAR	Toggle high-low to clear and re-arm status bit.
[1]	CLK_AVALID_CLEAR	Toggle high-low to clear and re-arm status bit.
[0]	PLL_LOCKED_CLEAR	Toggle high-low to clear and re-arm status bit.

Register 48: RESERVED
Register 49: CHARGE PUMP CONFIG

Bits	[7:1]	[0]
Default	7'b0000000	1'b1

Bits	Mnemonic	Description
[7:1]	RESERVED	N/A
[0]	CP_MUTE_PD_EN	Charge pump state control when the DAC mutes. <ul style="list-style-type: none"> 1'b0: Keep charge pump on when DAC mutes 1'b1: Power down charge pump when DAC mutes (default)

Register 50: RESERVED
Register 51: CHARGE PUMP CLOCK DIV

Bits	[7:0]
Default	8'd31

Bits	Mnemonic	Description
[7:0]	CP_CLK_DIV	Specifies the clk divider for the CP clock source. Valid from 8'd0 to 8'd255. $CP_CLK [Hz] = \frac{MCLK}{2^{\sim MCLK_RATE_SEL} \cdot (CP_CLK_DIV + 1)}$

Register 66-52: RESERVED

ES9081 Product Datasheet

GPIO Registers

Register 67: GPIO1/2 CONFIG

Bits	[7:4]	[3:0]
Default	4'd0	4'd0

Bits	Mnemonic	Description
[7:4]	GPIO2_CFG	Configure GPIO2 functionality. <ul style="list-style-type: none"> • 4'd0: Analog outputs off – shutdown (default) • 4'd1: Output 0 – output • 4'd2: Output 1 – output • 4'd3: Reserved • 4'd4: PLL locked flag – output • 4'd5: DAC Minimum Volume flag – output • 4'd6: DAC Automute status – output • 4'd7: DAC Soft Ramp Done flag – output • 4'd8: Mute all channels – input • 4'd9: System Mode control – input • 4'd10: OR of Status Bits – output • 4'd11: S/PDIF stream – output • 4'd12: PWM signal – output • 4'd13: MCLK_128FS – output • 4'd14: Reserved • 4'd15: Reserved
[3:0]	GPIO1_CFG	Configure GPIO1 functionality. <ul style="list-style-type: none"> • 4'd0: Analog outputs off – shutdown (default) • 4'd1: Output 0 – output • 4'd2: Output 1 – output • 4'd3: Reserved • 4'd4: PLL locked flag – output • 4'd5: DAC Minimum Volume flag – output • 4'd6: DAC Automute status – output • 4'd7: DAC Soft Ramp Done flag – output • 4'd8: Mute all channels – input • 4'd9: System Mode control – input • 4'd10: OR of Status Bits – output • 4'd11: S/PDIF stream – output • 4'd12: PWM signal – output • 4'd13: MCLK_128FS – output • 4'd14: Reserved • 4'd15: Reserved

Register 68: GPIO3/4 CONFIG

Bits	[7:4]	[3:0]
Default	4'd0	4'd0

Bits	Mnemonic	Description
[7:4]	GPIO4_CFG	Configure GPIO4 functionality. <ul style="list-style-type: none"> • 4'd0: Analog outputs off – shutdown (default) • 4'd1: Output 0 – output • 4'd2: Output 1 – output • 4'd3: Reserved • 4'd4: PLL locked flag – output • 4'd5: DAC Minimum Volume flag – output • 4'd6: DAC Automute status – output • 4'd7: DAC Soft Ramp Done flag – output • 4'd8: Mute all channels – input • 4'd9: System Mode control – input • 4'd10: OR of Status Bits – output • 4'd11: S/PDIF stream – output • 4'd12: PWM signal – output • 4'd13: MCLK_128FS – output • 4'd14: Reserved • 4'd15: Reserved
[3:0]	GPIO3_CFG	Configure GPIO3 functionality. <ul style="list-style-type: none"> • 4'd0: Analog outputs off – shutdown (default) • 4'd1: Output 0 – output • 4'd2: Output 1 – output • 4'd3: Reserved • 4'd4: PLL locked flag – output • 4'd5: DAC Minimum Volume flag – output • 4'd6: DAC Automute status – output • 4'd7: DAC Soft Ramp Done flag – output • 4'd8: Mute all channels – input • 4'd9: System Mode control – input • 4'd10: OR of Status Bits – output • 4'd11: S/PDIF stream – output • 4'd12: PWM signal – output • 4'd13: MCLK_128FS – output • 4'd14: Reserved • 4'd15: Reserved

ES9081 Product Datasheet

Register 69: GPIO5/6 CONFIG

Bits	[7:4]	[3:0]
Default	4'd0	4'd0

Bits	Mnemonic	Description
[7:4]	GPIO6_CFG	Configure GPIO6 functionality. <ul style="list-style-type: none"> • 4'd0: Analog outputs off – shutdown (default) • 4'd1: Output 0 – output • 4'd2: Output 1 – output • 4'd3: Reserved • 4'd4: PLL locked flag – output • 4'd5: DAC Minimum Volume flag – output • 4'd6: DAC Automute status – output • 4'd7: DAC Soft Ramp Done flag – output • 4'd8: Mute all channels – input • 4'd9: System Mode control – input • 4'd10: OR of Status Bits – output • 4'd11: S/PDIF stream – output • 4'd12: PWM signal – output • 4'd13: MCLK_128FS – output • 4'd14: Reserved • 4'd15: Reserved
[3:0]	GPIO5_CFG	Configure GPIO5 functionality. <ul style="list-style-type: none"> • 4'd0: Analog outputs off – shutdown (default) • 4'd1: Output 0 – output • 4'd2: Output 1 – output • 4'd3: Reserved • 4'd4: PLL locked flag – output • 4'd5: DAC Minimum Volume flag – output • 4'd6: DAC Automute status – output • 4'd7: DAC Soft Ramp Done flag – output • 4'd8: Mute all channels – input • 4'd9: System Mode control – input • 4'd10: OR of Status Bits – output • 4'd11: S/PDIF stream – output • 4'd12: PWM signal – output • 4'd13: MCLK_128FS – output • 4'd14: Reserved • 4'd15: Reserved

Register 71-70: RESERVED
Register 73-72: GPIO INPUT CONTROL

Bits	[15]	[14]	[13:6]	[5]	[4]	[3]	[2]	[1]	[0]
Default	1'b0	1'b0	7'b0000000	1'b0	1'b0	1'b0	1'b0	1'b0	1'b1

Bits	Mnemonic	Description
[15]	GPIO1_AS_DATA8	Repurposes the GPIO1 input as the DATA8 input. <ul style="list-style-type: none"> 1'b0: Disabled (default) 1'b1: Enabled
[14]	GPIO_SYSTEM_MODE	When any GPIO_CFG is "System mode control": <ul style="list-style-type: none"> 1'b0: Disable DAC when GPIOx input is 1'b1 1'b1: Enable DAC when GPIO input is 1'b1 When GPIOx input is 1'b0, system mode is determined by register 0[0] ENABLE_DAC.
[13:6]	RESERVED	N/A
[5]	GPIO6_SDB	<ul style="list-style-type: none"> 1'b0: Disables GPIO6 input (default) 1'b1: Enables GPIO6 input
[4]	GPIO5_SDB	<ul style="list-style-type: none"> 1'b0: Disables GPIO5 input (default) 1'b1: Enables GPIO5 input
[3]	GPIO4_SDB	<ul style="list-style-type: none"> 1'b0: Disables GPIO4 input (default) 1'b1: Enables GPIO4 input
[2]	GPIO3_SDB	<ul style="list-style-type: none"> 1'b0: Disables GPIO3 input (default) 1'b1: Enables GPIO3 input
[1]	GPIO2_SDB	<ul style="list-style-type: none"> 1'b0: Disables GPIO2 input (default) 1'b1: Enables GPIO2 input
[0]	GPIO1_SDB	<ul style="list-style-type: none"> 1'b0: Disables GPIO1 input 1'b1: Enables GPIO1 input (default)

ES9081 Product Datasheet

Register 75-74: GPIO OUTPUT CONTROL

Bits	[15]	[14]	[13]	[12:6]	[5]	[4]	[3]	[2]	[1]	[0]
Default	1'b1	1'b1	1'b1	6'b000000	1'b0	1'b0	1'b0	1'b0	1'b0	1'b0

Bits	Mnemonic	Description
[15]	GPIO_AND_SS_RAMP	<p>Sets the GPIO_CFG "Soft Ramp Done" flag output as the bitwise AND of both channel's flags.</p> <ul style="list-style-type: none"> 1'b0: Disabled 1'b1: Enabled, GPIO_CFG output is $\&(\text{ss_full_ramp}[\text{CHx}]$) (default) <p>Note: overridden by GPIO_OR_SS_RAMP.</p>
[14]	GPIO_AND_AUTOMUTE	<p>Sets the GPIO_CFG "Automute Status" output as the bitwise AND of both channel's statuses.</p> <ul style="list-style-type: none"> 1'b0: Disabled 1'b1: Enabled, GPIO_CFG output is $\&(\text{automute}[\text{CHx}]$) (default) <p>Note: overridden by GPIO_OR_AUTOMUTE.</p>
[13]	GPIO_AND_VOL_MIN	<p>Sets the GPIO_CFG "Minimum Volume" flag output as the bitwise AND of both channel's flags.</p> <ul style="list-style-type: none"> 1'b0: Disabled 1'b1: Enabled, GPIO_CFG output is $\&(\text{vol_min}[\text{CHx}]$) (default) <p>Note: overridden by GPIO_OR_VOL_MIN.</p>
[12:6]	RESERVED	N/A
[5]	GPIO6_OE	<ul style="list-style-type: none"> 1'b0: Tristate GPIO6 (default) 1'b1: GPIO6 Output enabled
[4]	GPIO5_OE	<ul style="list-style-type: none"> 1'b0: Tristate GPIO5 (default) 1'b1: GPIO5 Output enabled
[3]	GPIO4_OE	<ul style="list-style-type: none"> 1'b0: Tristate GPIO4 (default) 1'b1: GPIO4 Output enabled
[2]	GPIO3_OE	<ul style="list-style-type: none"> 1'b0: Tristate GPIO3 (default) 1'b1: GPIO3 Output enabled
[1]	GPIO2_OE	<ul style="list-style-type: none"> 1'b0: Tristate GPIO2 (default) 1'b1: GPIO2 Output enabled
[0]	GPIO1_OE	<ul style="list-style-type: none"> 1'b0: Tristate GPIO1 (default) 1'b1: GPIO1 Output enabled

Register 77-76: GPIO INVERT CONTROL

Bits	[15]	[14]	[13]	[12:6]	[5]	[4]	[3]	[2]	[1]	[0]
Default	1'b0	1'b0	1'b0	6'b000000	1'b0	1'b0	1'b0	1'b0	1'b0	1'b0

Bits	Mnemonic	Description
[15]	GPIO_OR_SS_RAMP	Sets the GPIO_CFG "Soft Ramp Done" flag output as the bitwise OR of both channel's flags. <ul style="list-style-type: none"> 1'b0: Disabled (default) 1'b1: Enabled, GPIO_CFG output is (ss_full_ramp[CHx])
[14]	GPIO_OR_AUTOMUTE	Sets the GPIO_CFG "Automute Status" output as the bitwise OR of both channel's statuses. <ul style="list-style-type: none"> 1'b0: Disabled (default) 1'b1: Enabled, GPIO_CFG output is (automute[CHx])
[13]	GPIO_OR_VOL_MIN	Sets the GPIO_CFG "Minimum Volume" flag output as the bitwise OR of both channel's flags. <ul style="list-style-type: none"> 1'b0: Disabled (default) 1'b1: Enabled, GPIO_CFG output is (vol_min[CHx])
[12:6]	RESERVED	N/A
[5]	GPIO6_INV	Invert the GPIO6 input and output. <ul style="list-style-type: none"> 1'b0: Non-inverted (default) 1'b1: Inverted
[4]	GPIO5_INV	Invert the GPIO5 input and output. <ul style="list-style-type: none"> 1'b0: Non-inverted (default) 1'b1: Inverted
[3]	GPIO4_INV	Invert the GPIO4 input and output. <ul style="list-style-type: none"> 1'b0: Non-inverted (default) 1'b1: Inverted
[2]	GPIO3_INV	Invert the GPIO3 input and output. <ul style="list-style-type: none"> 1'b0: Non-inverted (default) 1'b1: Inverted
[1]	GPIO2_INV	Invert the GPIO2 input and output. <ul style="list-style-type: none"> 1'b0: Non-inverted (default) 1'b1: Inverted
[0]	GPIO1_INV	Invert the GPIO1 input and output. <ul style="list-style-type: none"> 1'b0: Non-inverted (default) 1'b1: Inverted

ES9081 Product Datasheet

Register 79-78: GPIO KEEPER CONTROL

Bits	[15:6]	[5]	[4]	[3]	[2]	[1]	[0]
Default	10'b0000000000	1'b0	1'b0	1'b0	1'b0	1'b0	1'b0

Bits	Mnemonic	Description
[15:6]	RESERVED	N/A
[5]	GPIO6_WK_EN	<ul style="list-style-type: none"> 1'b0: GPIO6 weak keeper disabled (default) 1'b1: GPIO6 weak keeper enabled
[4]	GPIO5_WK_EN	<ul style="list-style-type: none"> 1'b0: GPIO5 weak keeper disabled (default) 1'b1: GPIO5 weak keeper enabled
[3]	GPIO4_WK_EN	<ul style="list-style-type: none"> 1'b0: GPIO4 weak keeper disabled (default) 1'b1: GPIO4 weak keeper enabled
[2]	GPIO3_WK_EN	<ul style="list-style-type: none"> 1'b0: GPIO3 weak keeper disabled (default) 1'b1: GPIO3 weak keeper enabled
[1]	GPIO2_WK_EN	<ul style="list-style-type: none"> 1'b0: GPIO2 weak keeper disabled (default) 1'b1: GPIO2 weak keeper enabled
[0]	GPIO1_WK_EN	<ul style="list-style-type: none"> 1'b0: GPIO1 weak keeper disabled (default) 1'b1: GPIO1 weak keeper enabled

Register 81-80: GPIO READ CONTROL

Bits	[15:6]	[5]	[4]	[3]	[2]	[1]	[0]
Default	9'b000000000	1'b0	1'b0	1'b0	1'b0	1'b0	1'b0

Bits	Mnemonic	Description
[15:6]	RESERVED	N/A
[5]	GPIO6_READ	Enables readback of the GPIO6 input. <ul style="list-style-type: none"> 1'b0: Disabled (default) 1'b1: Enabled
[4]	GPIO5_READ	Enables readback of the GPIO5 input. <ul style="list-style-type: none"> 1'b0: Disabled (default) 1'b1: Enabled
[3]	GPIO4_READ	Enables readback of the GPIO4 input. <ul style="list-style-type: none"> 1'b0: Disabled (default) 1'b1: Enabled
[2]	GPIO3_READ	Enables readback of the GPIO3 input. <ul style="list-style-type: none"> 1'b0: Disabled (default) 1'b1: Enabled
[1]	GPIO2_READ	Enables readback of the GPIO2 input. <ul style="list-style-type: none"> 1'b0: Disabled (default) 1'b1: Enabled
[0]	GPIO1_READ	Enables readback of the GPIO1 input. <ul style="list-style-type: none"> 1'b0: Disabled (default) 1'b1: Enabled

Register 82: PWM COUNT

Bits	[7:0]
Default	8'h00

Bits	Mnemonic	Description
[7:0]	PWM_COUNT	8-bit value setting the number of MCLK periods the PWM signal is high for. <ul style="list-style-type: none"> 8'h00: Disabled (default) 8'h01: Minimum 8'hFF: Maximum

Register 84-83: PWM FREQUENCY

Bits	[15:0]
Default	16'h0000

Bits	Mnemonic	Description
[15:0]	PWM_FREQ	16-bit value to set the frequency of the PWM signal in terms of MCLK divisions. <ul style="list-style-type: none"> 16'h0000: Disabled (default) 16'h0001: Minimum 16'hFFFF: Maximum $\text{frequency [Hz]} = \frac{MCLK}{PWM_FREQ + 1}$ $\text{Duty Cycle [\%]} = \frac{PWM_COUNT}{PWM_FREQ + 1} \cdot 100$

ES9081 Product Datasheet

DAC Registers

Register 85: RESERVED

Register 86: DAC FILTER CONFIG

Bits	[7:6]	[5]	[4]	[3]	[2:0]
Default	2'd0	1'b0	1'b0	1'b0	3'd0

Bits	Mnemonic	Description
[7:6]	RESERVED	N/A
[5]	BYPASS_IIR	Bypass the IIR filter. <ul style="list-style-type: none"> 1'b0: Non-bypassed (default) 1'b1: Bypassed
[4]	BYPASS_FIR4X	Bypass the 4X FIR filter. <ul style="list-style-type: none"> 1'b0: Non-bypassed (default) 1'b1: Bypassed
[3]	BYPASS_FIR2X	Bypass the 2X FIR filter. <ul style="list-style-type: none"> 1'b0: Non-bypassed (default) 1'b1: Bypassed
[2:0]	FILTER_SHAPE	Selects the 8x interpolation FIR filter shape. <ul style="list-style-type: none"> 3'd0: Minimum phase (default) 3'd1: Linear phase fast roll-off apodizing 3'd2: Linear phase fast roll-off 3'd3: Linear phase fast roll-off low ripple 3'd4: Linear phase slow roll-off 3'd5: Minimum phase fast roll-off 3'd6: Minimum phase slow roll-off 3'd7: Minimum phase slow roll-off low dispersion

Register 87: VOLUME CH1

Bits	[7:0]
Default	8'h02

Bits	Mnemonic	Description
[7:0]	VOLUME_CH1	DAC CH1 volume. +1dB to -126dB, 0.5dB steps <ul style="list-style-type: none"> 8'h00: +1dB 8'h02: 0dB (default) 8'hFE: -126dB 8'hFF: Mute

Register 88: VOLUME CH2

Bits	[7:0]
Default	8'h02

Bits	Mnemonic	Description
[7:0]	VOLUME_CH2	DAC CH2 volume. +1dB to -126dB, 0.5dB steps <ul style="list-style-type: none"> • 8'h00: +1dB • 8'h02: 0dB (default) • 8'hFE: -126dB • 8'hFF: Mute

Register 89: VOLUME CH3

Bits	[7:0]
Default	8'h02

Bits	Mnemonic	Description
[7:0]	VOLUME_CH3	DAC CH3 volume. +1dB to -126dB, 0.5dB steps <ul style="list-style-type: none"> • 8'h00: +1dB • 8'h02: 0dB (default) • 8'hFE: -126dB • 8'hFF: Mute

Register 90: VOLUME CH4

Bits	[7:0]
Default	8'h02

Bits	Mnemonic	Description
[7:0]	VOLUME_CH4	DAC CH4 volume. +1dB to -126dB, 0.5dB steps <ul style="list-style-type: none"> • 8'h00: +1dB • 8'h02: 0dB (default) • 8'hFE: -126dB • 8'hFF: Mute

ES9081 Product Datasheet

Register 91: VOLUME CH5

Bits	[7:0]
Default	8'h02

Bits	Mnemonic	Description
[7:0]	VOLUME_CH5	DAC CH5 volume. +1dB to -126dB, 0.5dB steps <ul style="list-style-type: none"> 8'h00: +1dB 8'h02: 0dB (default) 8'hFE: -126dB 8'hFF: Mute

Register 92: VOLUME CH6

Bits	[7:0]
Default	8'h02

Bits	Mnemonic	Description
[7:0]	VOLUME_CH6	DAC CH6 volume. +1dB to -126dB, 0.5dB steps <ul style="list-style-type: none"> 8'h00: +1dB 8'h02: 0dB (default) 8'hFE: -126dB 8'hFF: Mute

Register 93: VOLUME CH7

Bits	[7:0]
Default	8'h02

Bits	Mnemonic	Description
[7:0]	VOLUME_CH7	DAC CH7 volume. +1dB to -126dB, 0.5dB steps <ul style="list-style-type: none"> 8'h00: +1dB 8'h02: 0dB (default) 8'hFE: -126dB 8'hFF: Mute

Register 94: VOLUME CH8

Bits	[7:0]
Default	8'h02

Bits	Mnemonic	Description
[7:0]	VOLUME_CH8	DAC CH8 volume. +1dB to -126dB, 0.5dB steps <ul style="list-style-type: none"> 8'h00: +1dB 8'h02: 0dB (default) 8'hFE: -126dB 8'hFF: Mute

Register 95: PHASE INVERSION

Bits	[7]	[6]	[5]	[4]	[3]	[2]	[1]	[0]
Default	1'b0	1'b0	1'b0	1'b0	1'b0	1'b0	1'b0	1'b0

Bits	Mnemonic	Description
[7]	VOL_PHASE_INV_CH8	Inverts the phase of VOLUME_CH8. <ul style="list-style-type: none"> 1'b0: Non-inverted (default) 1'b1: Inverted
[6]	VOL_PHASE_INV_CH7	Inverts the phase of VOLUME_CH7. <ul style="list-style-type: none"> 1'b0: Non-inverted (default) 1'b1: Inverted
[5]	VOL_PHASE_INV_CH6	Inverts the phase of VOLUME_CH6. <ul style="list-style-type: none"> 1'b0: Non-inverted (default) 1'b1: Inverted
[4]	VOL_PHASE_INV_CH5	Inverts the phase of VOLUME_CH5. <ul style="list-style-type: none"> 1'b0: Non-inverted (default) 1'b1: Inverted
[3]	VOL_PHASE_INV_CH4	Inverts the phase of VOLUME_CH4. <ul style="list-style-type: none"> 1'b0: Non-inverted (default) 1'b1: Inverted
[2]	VOL_PHASE_INV_CH3	Inverts the phase of VOLUME_CH3. <ul style="list-style-type: none"> 1'b0: Non-inverted (default) 1'b1: Inverted
[1]	VOL_PHASE_INV_CH2	Inverts the phase of VOLUME_CH2. <ul style="list-style-type: none"> 1'b0: Non-inverted (default) 1'b1: Inverted
[0]	VOL_PHASE_INV_CH1	Inverts the phase of VOLUME_CH1. <ul style="list-style-type: none"> 1'b0: Non-inverted (default) 1'b1: Inverted

ES9081 Product Datasheet

Register 99-96: DIGITAL GAIN

Bits	[31:30]	[29:27]	[26:24]	[23:22]	[21:19]	[18:16]	[15:14]	[13:11]	[10:8]	[7:6]	[5:3]	[2:0]
Default	2'd0	3'd0	3'd0	2'd0	3'd0	3'd0	2'd0	3'd0	3'd0	2'd0	3'd0	3'd0

Bits	Mnemonic	Description
[31:30]	RESERVED	N/A
[29:27]	DIGITAL_GAIN_CH8	DAC CH8 gain boost. +0dB to +42dB, +6dB steps. <ul style="list-style-type: none"> 3'd0: +0dB (default) 3'd7: +42dB
[26:24]	DIGITAL_GAIN_CH7	DAC CH7 gain boost. +0dB to +42dB, +6dB steps. <ul style="list-style-type: none"> 3'd0: +0dB (default) 3'd7: +42dB
[23:22]	RESERVED	N/A
[21:19]	DIGITAL_GAIN_CH6	DAC CH6 gain boost. +0dB to +42dB, +6dB steps. <ul style="list-style-type: none"> 3'd0: +0dB (default) 3'd7: +42dB
[18:16]	DIGITAL_GAIN_CH5	DAC CH5 gain boost. +0dB to +42dB, +6dB steps. <ul style="list-style-type: none"> 3'd0: +0dB (default) 3'd7: +42dB
[15:14]	RESERVED	N/A
[13:11]	DIGITAL_GAIN_CH4	DAC CH4 gain boost. +0dB to +42dB, +6dB steps. <ul style="list-style-type: none"> 3'd0: +0dB (default) 3'd7: +42dB
[10:8]	DIGITAL_GAIN_CH3	DAC CH3 gain boost. +0dB to +42dB, +6dB steps. <ul style="list-style-type: none"> 3'd0: +0dB (default) 3'd7: +42dB
[7:6]	RESERVED	N/A
[5:3]	DIGITAL_GAIN_CH2	DAC CH2 gain boost. +0dB to +42dB, +6dB steps. <ul style="list-style-type: none"> 3'd0: +0dB (default) 3'd7: +42dB
[2:0]	DIGITAL_GAIN_CH1	DAC CH1 gain boost. +0dB to +42dB, +6dB steps. <ul style="list-style-type: none"> 3'd0: +0dB (default) 3'd7: +42dB

Register 100: MUTE

Bits	[7]	[6]	[5]	[4]	[3]	[2]	[1]	[0]
Default	1'b0	1'b0	1'b0	1'b0	1'b0	1'b0	1'b0	1'b0

Bits	Mnemonic	Description
[7]	MUTE_CH8	Mutes the CH8 datapath. <ul style="list-style-type: none"> 1'b0: Normal CH8 operation (default) 1'b1: Mute CH8
[6]	MUTE_CH7	Mutes the CH7 datapath. <ul style="list-style-type: none"> 1'b0: Normal CH7 operation (default) 1'b1: Mute CH7
[5]	MUTE_CH6	Mutes the CH6 datapath. <ul style="list-style-type: none"> 1'b0: Normal CH6 operation (default) 1'b1: Mute CH6
[4]	MUTE_CH5	Mutes the CH5 datapath. <ul style="list-style-type: none"> 1'b0: Normal CH5 operation (default) 1'b1: Mute CH5
[3]	MUTE_CH4	Mutes the CH4 datapath. <ul style="list-style-type: none"> 1'b0: Normal CH4 operation (default) 1'b1: Mute CH4
[2]	MUTE_CH3	Mutes the CH3 datapath. <ul style="list-style-type: none"> 1'b0: Normal CH3 operation (default) 1'b1: Mute CH3
[1]	MUTE_CH2	Mutes the CH2 datapath. <ul style="list-style-type: none"> 1'b0: Normal CH2 operation (default) 1'b1: Mute CH2
[0]	MUTE_CH1	Mutes the CH1 datapath. <ul style="list-style-type: none"> 1'b0: Normal CH1 operation (default) 1'b1: Mute CH1

ES9081 Product Datasheet

Register 101: SOFT RAMP CONFIG

Bits	[7]	[6]	[5]	[4:0]
Default	1'b0	1'b0	1'b1	5'd3

Bits	Mnemonic	Description
[7]	RESERVED	N/A
[6]	MONO_VOLUME	All channel volumes controlled by the CH1 volume control. <ul style="list-style-type: none"> 1'b0: Disabled (default) 1'b1: Enabled
[5]	MUTE_RAMP_TO_GROUND	<ul style="list-style-type: none"> 1'b0: When ramped to min volume during normal mute, do not soft ramp to ground 1'b1: When ramped to min volume during normal mute, soft ramp to ground for power saving (default) normal mute includes: automute, mute by register, mute by GPIO
[4:0]	SOFT_RAMP_TIME	Sets the amount of time that it takes to perform a soft start ramp. This time affects both ramp to ground and ramp to AVCC/2. Valid from 0 to 20 (inclusive). $\text{Time [s]} = \frac{2^{15} \cdot 2^{\text{SOFT_RAMP_TIME}} \cdot 2^{\sim\text{MCLK_RATE_SEL}}}{\text{MCLK}}$

Register 102: VOLUME UP RAMP RATE

Bits	[7:0]
Default	8'h04

Bits	Mnemonic	Description
[7:0]	VOL_RAMP_RATE_UP	Linear step size from current volume to target volume, represented as a fraction of full-scale. $\text{Ramp_rate [dB/s]} = 20 \log_{10} \left(\frac{\text{VOL_RAMP_RATE_UP} \cdot \text{FS}}{2^{12}} \right)$ <ul style="list-style-type: none"> 8'h00: Instant change 8'h01: Slowest change 8'h04: Default 8'hFF: Fastest change

Register 103: VOLUME DOWN RAMP RATE

Bits	[7:0]
Default	8'h04

Bits	Mnemonic	Description
[7:0]	VOL_RAMP_RATE_DOWN	Linear step size from current volume to target volume, represented as a fraction of full-scale. $\text{Ramp_rate [dB/s]} = 20 \log_{10} \left(\frac{\text{VOL_RAMP_RATE_DOWN}}{2^{12}} \right)$ <ul style="list-style-type: none"> 8'h00: Instant change 8'h01: Slowest change 8'h04: Default 8'hFF: Fastest change

Register 104: DC OFFSET

Bits	[7:0]
Default	8'h00

Bits	Mnemonic	Description
[7:0]	DC_OFFSET	Signed 8-bit DC offset value added to the CH1 datapath signal, 100 uV/step. <ul style="list-style-type: none"> 8'hFF: -12.5mV DC Offset 8'h00: 0mV DC Offset (default) 8'h7F: 12.5mV DC Offset

ES9081 Product Datasheet

Register 105: AUTOMUTE ENABLE

Bits	[7]	[6]	[5]	[4]	[3]	[2]	[1]	[0]
Default	1'b1	1'b1	1'b1	1'b1	1'b1	1'b1	1'b1	1'b1

Bits	Mnemonic	Description
[7]	AUTOMUTE_EN_CH8	Enables CH8 automute. <ul style="list-style-type: none"> 1'b0: Disabled 1'b1: Enabled (default)
[6]	AUTOMUTE_EN_CH7	Enables CH7 automute. <ul style="list-style-type: none"> 1'b0: Disabled 1'b1: Enabled (default)
[5]	AUTOMUTE_EN_CH6	Enables CH6 automute. <ul style="list-style-type: none"> 1'b0: Disabled 1'b1: Enabled (default)
[4]	AUTOMUTE_EN_CH5	Enables CH5 automute. <ul style="list-style-type: none"> 1'b0: Disabled 1'b1: Enabled (default)
[3]	AUTOMUTE_EN_CH4	Enables CH4 automute. <ul style="list-style-type: none"> 1'b0: Disabled 1'b1: Enabled (default)
[2]	AUTOMUTE_EN_CH3	Enables CH3 automute. <ul style="list-style-type: none"> 1'b0: Disabled 1'b1: Enabled (default)
[1]	AUTOMUTE_EN_CH2	Enables CH2 automute. <ul style="list-style-type: none"> 1'b0: Disabled 1'b1: Enabled (default)
[0]	AUTOMUTE_EN_CH1	Enables CH1 automute. <ul style="list-style-type: none"> 1'b0: Disabled 1'b1: Enabled (default)

Register 107-106: AUTOMUTE TIME

Bits	[15]	[14]	[13]	[12:11]	[10:0]
Default	1'b1	1'b0	1'b0	2'd0	11'h0F

Bits	Mnemonic	Description
[15]	DSD_FAULT_DETECT_EN	Sets a channel to a DSD mute pattern (0x96) if the DSD data has no changes in 64 DATA_CLKs. <ul style="list-style-type: none"> 1'b0: Disabled 1'b1: Enabled (default)
[14]	DSD_DC_AM_ENB	Disables the DSD automute condition, if a DC signal is detected. <ul style="list-style-type: none"> 1'b0: Enabled (default) 1'b1: Disabled
[13]	DSD_MUTE_AM_ENB	Disables the DSD automute condition, if a DSD mute pattern is detected. <ul style="list-style-type: none"> 1'b0: Enabled (default) 1'b1: Disabled
[12:11]	RESERVED	N/A
[10:0]	AUTOMUTE_TIME	Configures the amount of time in seconds the audio must remain below AUTOMUTE_LEVEL before an automute condition is flagged. <ul style="list-style-type: none"> 11'h000: Disabled 11'h001: Slowest 11'h00F: Default 11'h7FF: Fastest $\text{Time [s]} = \frac{2^{18}}{\text{AUTOMUTE_TIME} \cdot FS}$

Register 109-108: AUTOMUTE LEVEL

Bits	[15:0]
Default	16'h0008

Bits	Mnemonic	Description
[15:0]	AUTOMUTE_LEVEL	The threshold which the audio must be below before an automute condition is flagged. <ul style="list-style-type: none"> 16'h0001: -138dB 16'h0008: -120dB (default) 16'hFFFF: -42dB $\text{level [dB]} = 20 \cdot \log_{10} \left(\frac{\text{AUTOMUTE_LEVEL}}{(2^{16} - 1) \cdot 2^7} \right)$

ES9081 Product Datasheet

Register 111-110: AUTOMUTE OFF LEVEL

Bits	[15:0]
Default	16'h000A

Bits	Mnemonic	Description
[15:0]	AUTOMUTE_OFF_LEVEL	<p>The threshold which the audio must be above before the automute condition is immediately cleared.</p> <ul style="list-style-type: none"> 16'h0001: -138dB 16'h000A: -118dB (default) 16'hFFFF: -42dB $\text{level [dB]} = 20 \cdot \log_{10} \left(\frac{\text{AUTOMUTE_OFF_LEVEL}}{(2^{16} - 1) \cdot 2^7} \right)$

Register 120-112: RESERVED

PLL Registers

Register 121: PLL CLOCK SELECT

Bits	[7]	[6]	[5:4]	[3]	[2:1]	[0]
Default	1'b0	1'b0	2'b10	1'b0	2'b00	1'b1

Bits	Mnemonic	Description
[7]	RESERVED	N/A
[6]	PLL_CLK_PHASE_INV	Digital/analog DAC clock invert phase enable. <ul style="list-style-type: none"> 1'b0: Digital/analog DAC clocks have inverted phase (default) 1'b1: Digital/analog DAC clocks have the same phase
[5:4]	SEL_PLL_CLK_IN	Selects PLL input clock source when EN_PLL_CLK_IN is set. <ul style="list-style-type: none"> 2'b00: ACLK 2'b10: DCLK (default) Others: Reserved
[3]	EN_PLL_CLK_IN	Allows SEL_PLL_CLK_IN to select PLL input clocks. <ul style="list-style-type: none"> 1'b0: Disables SEL_PLL_CLK_IN (default) 1'b1: Enables SEL_PLL_CLK_IN
[2:1]	SEL_MCLK_IN	Selects digital core clock source when EN_MCLK_IN is set. <ul style="list-style-type: none"> 2'b00: ACLK (default) 2'b10: PLL_CLK Others: Reserved
[0]	EN_MCLK_IN	Enables clock inputs to the digital core. <ul style="list-style-type: none"> 1'b0: Disabled 1'b1: Enabled (default)

Register 122: PLL VCO & CP

Bits	[7:4]	[3]	[2]	[1]	[0]
Default	4'b0011	1'b0	1'b0	1'b0	1'b0

Bits	Mnemonic	Description
[7:4]	RESERVED	N/A
[3]	PLL_CP_PDB	Enables/disables the PLL charge pump. <ul style="list-style-type: none"> 1'b0: Disabled (default) 1'b1: Enabled
[2]	PLL_VCO_PDB	Enables/disables the PLL voltage-controlled oscillator (VCO). <ul style="list-style-type: none"> 1'b0: Disabled (default) 1'b1: Enabled
[1]	PLL_CLKSMP_PDB	Power Down the PLL circuitry. <ul style="list-style-type: none"> 1'b0: PLL Block disabled (default) 1'b1: PLL Block enabled
[0]	PLL_DIG_RSTB	Resets the Digital core of the PLL.

ES9081 Product Datasheet

Register 123: PLL REGULATOR

Bits	[7:4]	[3]	[2:0]
Default	4'd0	1'b0	3'b010

Bits	Mnemonic	Description
[7:4]	RESERVED	N/A
[3]	PLL_REG_PDB	Power down the PLL regulator. <ul style="list-style-type: none"> 1'b0: Disable the PLL regulator (default) 1'b1: Enable the PLL regulator
[2:0]	RESERVED	N/A

Register 126-124: PLL FEEDBACK DIV

Bits	[23:0]
Default	24'h100000

Bits	Mnemonic	Description
[23:0]	PLL_CLK_FB_DIV	Sets the PLL clock feedback divider (Nfb). <ul style="list-style-type: none"> 24'h000000: Reserved 24'h100000: Default 24'hn: Divide by $2^{(n-25)}/n$

Register 129-127: PLL IN & OUT DIV

Bits	[23:16]	[15:12]	[11:10]	[9]	[8:0]
Default	8'b00010000	4'd3	2'd0	1'b1	9'd0

Bits	Mnemonic	Description
[23:16]	RESERVED	N/A
[15:12]	PLL_CLK_OUT_DIV	Sets the PLL clock output divider (No). <ul style="list-style-type: none"> 4'd0: Reserved 4'd3: Divide by 4. (default) 4'dn: Divide by (n + 1).
[11:10]	RESERVED	N/A
[9]	PLL_FB_DIV_LOAD	Write 1'b1 then write 1'b0 to load CLK_FB_DIV.
[8:0]	PLL_CLK_IN_DIV	Sets the PLL clock input divider (Ni). <ul style="list-style-type: none"> 9'd0: Reserved (default) 9'dn: Divide by (n + 1).

Register 135-130: RESERVED

Readback Registers

Register 224: INPUT FORMAT READ

Bits	[7:4]	[3]	[2:1]	[0]
Default	-	-	-	-

Bits	Mnemonic	Description
[7:4]	DOP_VALID	DoP Valid flags, per channel pair.
[3]	DAC_TDM_VALID	TDM decoder valid flag.
[2:1]	INPUT_SEL_OVERRIDE	Readback of the current input data format. <ul style="list-style-type: none"> • 2'd0: PCM (default) • 2'd1: DSD • 2'd2: DoP • 2'd3: Reserved
[0]	PLL_LOCKED	PLL locked flag.

Register 225: CHIP ID

Bits	[7:0]
Default	8'h70

Bits	Mnemonic	Description
[7:0]	CHIP_ID	Chip ID. <ul style="list-style-type: none"> • ES9081: 0x73



ES9081 Product Datasheet

Register 228-226: RESERVED

Register 232-229: STATUS BITS STATE

Bits	[31]	[30:29]	[28]	[27]	[26]	[25]	[24]	[23:16]	[15:8]	[7:0]
Default	-	-	-	-	-	-	-	-	-	-

Bits	Mnemonic	Description
[31]	RESERVED	N/A
[30:29]	INPUT_SEL_OVR_STATE	State of the masked INPUT_SELECT_OVERRIDE status bits. Note: Clear bits are required to reset value.
[28]	DOP_VALID_CH12_STATE	State of the masked DOP_VALID status bit. Note: Clear bits are required to reset value.
[27]	TDM_DATA_VALID_STATE	State of the masked TDM_DATA_VALID status bit. Note: Clear bits are required to reset value.
[26]	BCK_WS_FAIL_STATE	State of the masked BCK_WS_FAIL status bit. Note: Clear bits are required to reset value.
[25]	RESERVED	N/A
[24]	PLL_LOCKED_STATE	State of the masked PLL_LOCKED status bit. Note: Clear bits are required to reset value.
[23:16]	SS_FULL_RAMP_STATE	State of each channel's "Soft Ramp Done" status bit. Note: Clear bits are required to reset value.
[15:8]	AUTOMUTE_STATE	State of each channel's "Automute Status" status bit. Note: Clear bits are required to reset value.
[7:0]	VOL_MIN_STATE	State of each channel's "Minimum Volume" status bit. Note: Clear bits are required to reset value.

Register 233: RESERVED
Register 234: AUTO FS READ

Bits	[7]	[6]	[5:0]
Default	-	-	-

Bits	Mnemonic	Description
[7]	EN_64FS_MODE_AUTO	Result {Z} of the automatic sample rate detect (reg0[3] AUTO_FS_DETECT) logic, running the device in 64FS mode. <ul style="list-style-type: none"> 1'b0: 64FS disabled 1'b1: 64FS enabled
[6]	MCLK_128FS_HALF_DIV_AUTO	Result {Y} of the automatic sample rate detect (reg0[3] AUTO_FS_DETECT) logic. <ul style="list-style-type: none"> 1'b0: MCLK_128FS is an integer multiple of MCLK, Y = 1. 1'b1: MCLK_128FS is a (X+1)*0.5 multiple of MCLK, Y = 2.
[5:0]	MCLK_128FS_DIV_AUTO	Result {X} of the automatic sample rate detect (reg0[3] AUTO_FS_DETECT) logic. $FS [Hz] = \frac{Y \cdot MCLK}{(X + 1) \cdot \left(\frac{128^Z}{2}\right)}$

Register 235: CLOCK VALIDITY

Bits	[7]	[6]	[5]	[4:0]
Default	-	-	-	-

Bits	Mnemonic	Description
[7]	RATIO_VALID	Validity of the MCLK/MCLK_128FS ratio. <ul style="list-style-type: none"> 1'b0: Invalid ratio 1'b1: Valid ratio
[6]	BCK_INVALID	Validity of the BCK signal, requires BCK_MONITOR to be enabled.
[5]	WS_INVALID	Validity of the WS signal, requires WS_MONITOR to be enabled.
[4:0]	AUTO_CH_NUM	Automatic TDM channel number tuning result.

ES9081 Product Datasheet

Register 237-236: GPIO READBACK

Bits	[15:6]	[5]	[4]	[3]	[2]	[1]	[0]
Default	-	-	-	-	-	-	-

Bits	Mnemonic	Description
[15:6]	RESERVED	N/A
[5]	GPIO6_R	GPIO6 input readback.
[4]	GPIO5_R	GPIO5 input readback.
[3]	GPIO4_R	GPIO4 input readback.
[2]	GPIO3_R	GPIO3 input readback.
[1]	GPIO2_R	GPIO2 input readback.
[0]	GPIO1_R	GPIO1 input readback.

Register 238: VOL MIN READ

Bits	[7]	[6]	[5]	[4]	[3]	[2]	[1]	[0]
Default	-	-	-	-	-	-	-	-

Bits	Mnemonic	Description
[7]	VOL_MIN_CH8	CH8 minimum volume flag.
[6]	VOL_MIN_CH7	CH7 minimum volume flag.
[5]	VOL_MIN_CH6	CH6 minimum volume flag.
[4]	VOL_MIN_CH5	CH5 minimum volume flag.
[3]	VOL_MIN_CH4	CH4 minimum volume flag.
[2]	VOL_MIN_CH3	CH3 minimum volume flag.
[1]	VOL_MIN_CH2	CH2 minimum volume flag.
[0]	VOL_MIN_CH1	CH1 minimum volume flag.

Register 239: AUTOMUTE READ

Bits	[7]	[6]	[5]	[4]	[3]	[2]	[1]	[0]
Default	-	-	-	-	-	-	-	-

Bits	Mnemonic	Description
[7]	AUTOMUTE_CH8	CH2 automute status flag.
[6]	AUTOMUTE_CH7	CH1 automute status flag.
[5]	AUTOMUTE_CH6	CH2 automute status flag.
[4]	AUTOMUTE_CH5	CH1 automute status flag.
[3]	AUTOMUTE_CH4	CH2 automute status flag.
[2]	AUTOMUTE_CH3	CH1 automute status flag.
[1]	AUTOMUTE_CH2	CH2 automute status flag.
[0]	AUTOMUTE_CH1	CH1 automute status flag.

Register 240: SOFT RAMP UP READ

Bits	[7]	[6]	[5]	[4]	[3]	[2]	[1]	[0]
Default	-	-	-	-	-	-	-	-

Bits	Mnemonic	Description
[7]	SS_RAMP_UP_CH8	CH2 soft ramped up flag.
[6]	SS_RAMP_UP_CH7	CH1 soft ramped up flag.
[5]	SS_RAMP_UP_CH6	CH2 soft ramped up flag.
[4]	SS_RAMP_UP_CH5	CH1 soft ramped up flag.
[3]	SS_RAMP_UP_CH4	CH2 soft ramped up flag.
[2]	SS_RAMP_UP_CH3	CH1 soft ramped up flag.
[1]	SS_RAMP_UP_CH2	CH2 soft ramped up flag.
[0]	SS_RAMP_UP_CH1	CH1 soft ramped up flag.

Register 241: SOFT RAMP DOWN READ

Bits	[7]	[6]	[5]	[4]	[3]	[2]	[1]	[0]
Default	-	-	-	-	-	-	-	-

Bits	Mnemonic	Description
[7]	SS_RAMP_DOWN_CH8	CH2 soft ramped down flag.
[6]	SS_RAMP_DOWN_CH7	CH1 soft ramped down flag.
[5]	SS_RAMP_DOWN_CH6	CH2 soft ramped down flag.
[4]	SS_RAMP_DOWN_CH5	CH1 soft ramped down flag.
[3]	SS_RAMP_DOWN_CH4	CH2 soft ramped down flag.
[2]	SS_RAMP_DOWN_CH3	CH1 soft ramped down flag.
[1]	SS_RAMP_DOWN_CH2	CH2 soft ramped down flag.
[0]	SS_RAMP_DOWN_CH1	CH1 soft ramped down flag.

Register 250-242: RESERVED

ES9081 Product Datasheet

ES9081 Reference Schematic

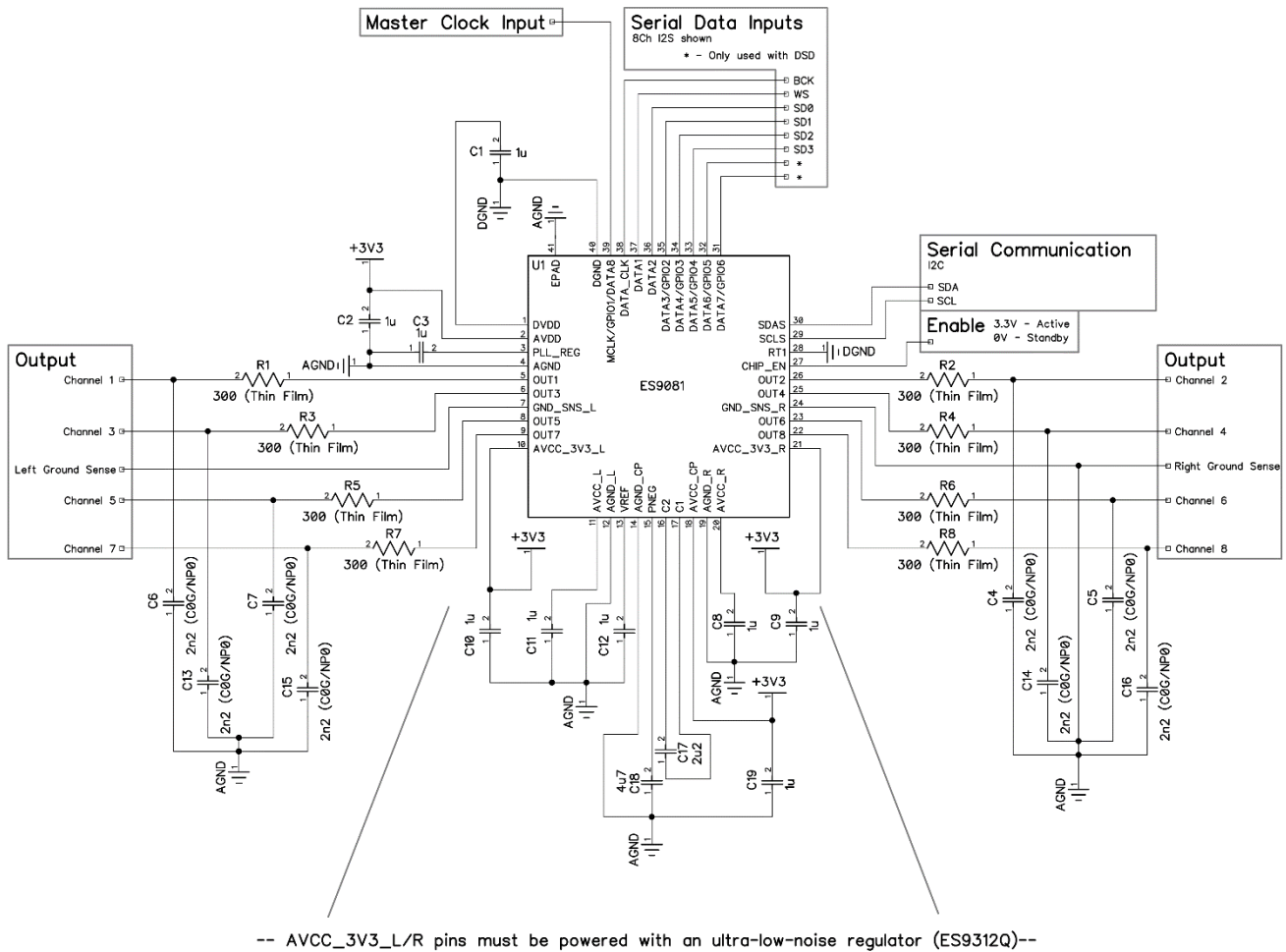

Figure 20 - ES9081 SW Mode Schematic

Note: The ES9081 40QFN package has an exposed pad (Pin 41) that should be connected to ground.

Recommended Power Supply

Figure 21 - ES9081 Power Supply Schematic

ES9081 Product Datasheet

Internal Pad Circuitry

Pin Name	Type	Pin	Equivalent Circuit
AVDD AVCC_3V3_L AVCC_CP AVCC_3V3_R	Power	2 10 18 21	
AGND AGND_L AGND_CP AGND_R DGND	Ground	4 12 14 19 40	
CHIP_EN	Reset	27	
RT1 SCL_SLAVE SDA_SLAVE DATA7/GPIO6 DATA6/GPIO5 DATA5/GPIO4 DATA4/GPIO3 DATA3/GPIO2 DATA2 DATA1 DATA_CLK MCLK/GPIO1/DATA8	Digital I/O	28 29 30 31 32 33 34 35 36 37 38 39	

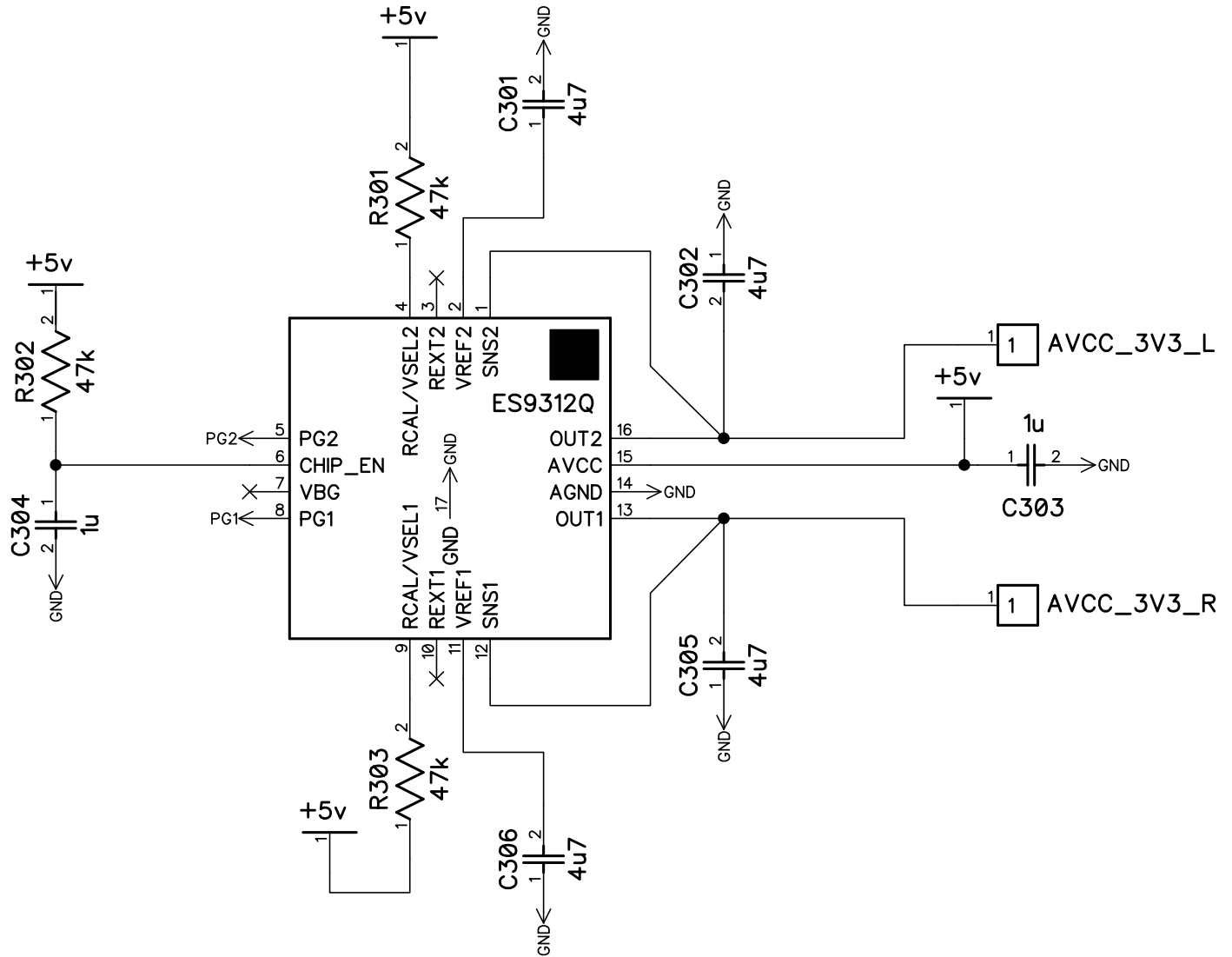
DVDD PLL_REG OUT1 OUT3 OUT5 OUT7 AVCC_L VREF PNEG AVCC_R OUT8 OUT6 OUT4 OUT2	Analog O	1 3 5 6 8 9 11 13 15 20 22 23 25 26	
GND_SNS_L GND_SNS_R	Analog I	7 24	

Table 25 – Internal Pad Circuitry

ES9081 Product Datasheet

40 QFN Package Dimensions

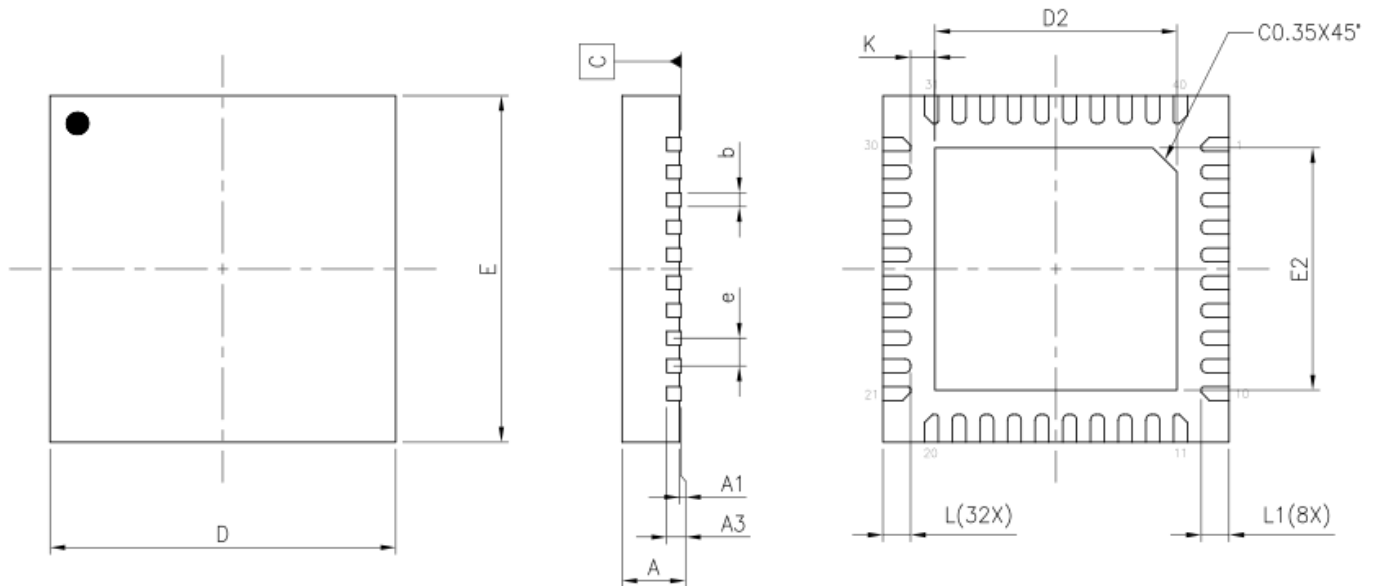

JEDEC OUTLINE	MO-220		
PKG CODE	WQFN(X540)		
SYMBOLS	MIN.	NOM.	MAX.
A	0.70	0.75	0.80
A1	0.00	0.02	0.05
A3	0.203 REF.		
b	0.15	0.20	0.25
D	5.00 BSC		
E	5.00 BSC		
e	0.40 BSC		
L	0.35	0.40	0.45
L1	0.33	0.38	0.43
K	0.20	-	-

PAD SIZE	D2			E2			LEAD FINISH		JEDEC CODE
	MIN.	NOM.	MAX.	MIN.	NOM.	MAX.	Pure Tin	PPF	
A150X15R MIL	3.40	3.50	3.60	3.40	3.50	3.60	V	X	W(V)HHE-1

NOTES :

1. ALL DIMENSIONS ARE IN MILLIMETERS.
2. DIMENSION b APPLIES TO METALLIZED TERMINAL AND IS MEASURED BETWEEN 0.15mm AND 0.30mm FROM THE TERMINAL TIP. IF THE TERMINAL HAS THE OPTIONAL RADIUS ON THE OTHER END OF THE TERMINAL, THE DIMENSION b SHOULD NOT BE MEASURED IN THAT RADIUS AREA.
3. BILATERAL COPLANARITY ZONE APPLIES TO THE EXPOSED HEAT SINK SLUG AS WELL AS THE TERMINALS.

Figure 22 - ES9081 40 QFN Package Dimensions

40 QFN Top View Marking

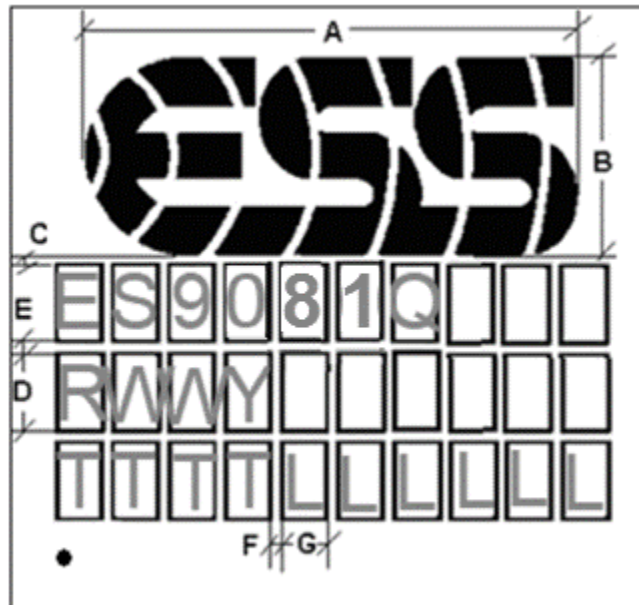

Package Type	Dimension in mm						
	A	B	C	D	E	F	G
QFN 5mm x 5mm	4.0	1.6	0.2	0.4	0.2	0.1	0.3

T	Tracking number
W	Work week
Y	Last digit of year
L	Lot number
R	Silicon Revision

Marking is subject to change. This drawing is not to scale.

Figure 23 - ES9081 48 QFN Top View Markings

ES9081 Product Datasheet

Reflow Process Considerations

Temperature Controlled

For lead-free soldering, the characterization and optimization of the reflow process is the most important factor to consider.

The lead-free alloy solder has a melting point of 217°C. This alloy requires a minimum reflow temperature of 235°C to ensure good wetting. The maximum reflow temperature is in the 245°C to 260°C range, depending on the package size (RPC-2-Pb-Free Process - Classification Temperatures (T_c)). This narrows the process window for lead-free soldering to 10°C to 20°C.

The increase in peak reflow temperature in combination with the narrow process window makes the development of an optimal reflow profile a critical factor for ensuring a successful lead-free assembly process. The major factors contributing to the development of an optimal thermal profile are the size and weight of the assembly, the density of the components, the mix of large and small components, and the paste chemistry being used.

Reflow profiling needs to be performed by attaching calibrated thermocouples well adhered to the device as well as other critical locations on the board to ensure that all components are heated to temperatures above the minimum reflow temperatures and that smaller components do not exceed the maximum temperature limits (Table RPC-2).

To ensure that all packages can be successfully and reliably assembled, the reflow profiles studied and recommended by ESS are based on the JEDEC/IPC standard J-STD-020 revision D.1.

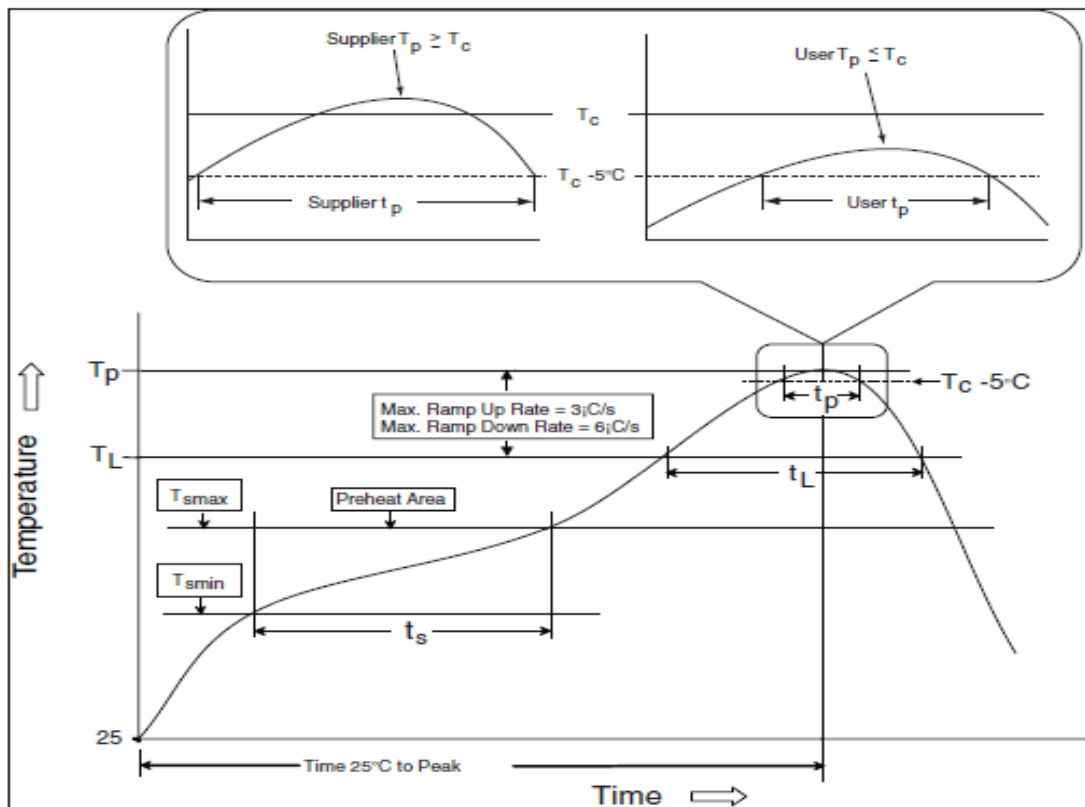

Figure 24 - IR/Convection Reflow Profile (IPC/JEDEC J-STD-020D.1)

Reflow is allowed 3 times. Caution must be taken to ensure time between re-flow runs does not exceed the allowed time by the moisture sensitivity label. If the time elapsed between the re-flows exceeds the moisture sensitivity time, bake the board according to the moisture sensitivity label instructions.

Manual

Allowed up to 2 times with maximum temperature of 350°C no longer than 3 seconds.

RPC-1 Classification Reflow Profile

Profile Feature	Pb-Free Assembly
Preheat/Soak	
Temperature Min (T _{min})	150°C
Temperature Max (T _{max})	200°C
Time (ts) from (T _{min} to T _{max})	60-120 seconds
Ramp-up rate (TL to T _p)	3°C / second maximum
Liquidous temperature (TL)	217°C
Time (tL) maintained above TL	60-150 seconds
Peak package body temperature (T _p)	For users T _p must not exceed the classification temp in Table RPC-2. For suppliers T _p must equal or exceed the Classification temp in Table RPC-2.
Time (t _p)* within 5°C of the specified classification temperature (T _c)	30* seconds
Ramp-down rate (T _p to TL)	6°C / second maximum
Time 25°C to peak temperature	8 minutes maximum
* Tolerance for peak profile temperature (T _p) is defined as a supplier minimum and a user maximum.	

Table 26 - RPC-1 Classification Reflow Profile

All temperatures refer to the center of the package, measured on the package body surface that is facing up during assembly reflow (e.g., live-bug). If parts are reflowed in other than the normal live-bug assembly reflow orientation (i.e., dead-bug), T_p shall be within $\pm 2^\circ\text{C}$ of the live-bug T_p and still meet the T_c requirements, otherwise, the profile shall be adjusted to achieve the latter. To accurately measure actual peak package body temperatures, refer to JEP140 for recommended thermocouple use.

Reflow profiles in this document are for classification/preconditioning and are not meant to specify board assembly profiles. Actual board assembly profiles should be developed based on specific process needs and board designs and should not exceed the parameters in Table RPC-1.

For example, if T_c is 260°C and time t_p is 30 seconds, this means the following for the supplier and the user.

For a supplier: The peak temperature must be at least 260°C. The time above 255°C must be at least 30 seconds.

For a user: The peak temperature must not exceed 260°C. The time above 255°C must not exceed 30 seconds.

All components in the test load shall meet the classification profile requirements.

ES9081 Product Datasheet

RPC-2 Pb-Free Process - Classification Temperatures (Tc)

Package Thickness	Volume mm ³ , <350	Volume mm ³ , 350 to 2000	Volume mm ³ , >2000
<1.6 mm	260°C	260°C	260°C
1.6 mm – 2.5 mm	260°C	250°C	245°C
>2.5 mm	250°C	245°C	245°C

Table 27 - RPC-2 Pb Free Classification Temperatures

At the discretion of the device manufacturer, but not the board assembler/user, the maximum peak package body temperature (Tp) can exceed the values specified in Table RPC-2. The use of a higher Tp does not change the classification temperature (Tc).

Package volume excludes external terminals (e.g., balls, bumps, lands, leads) and/or nonintegral heat sinks.

The maximum component temperature reached during reflow depends on package thickness and volume. The use of convection reflow processes reduces the thermal gradients between packages. However, thermal gradients due to differences in thermal mass of SMD packages may still exist.

Ordering Information

Part Number	Description	Package
ES9081Q	SABRE 32-bit 8 Channel DAC with Built-In Line Driver	5mm x 5mm 40 QFN

Table 28 - Ordering Information

Revision History

Current Version 0.2.1

Rev.	Date	Notes
0.2.0	September, 2024	Initial release
0.2.1	September, 2024	<ul style="list-style-type: none">Updated front page featuresAdded sample rate for S/PDIF encoderUpdated performance conditions

© 2024 ESS Technology, Inc.

ESS ICs are not intended, authorized, or warranted for use as components in military applications, medical devices or life support systems. ESS assumes no liability and disclaims any expressed, implied or statutory warranty for use of ESS ICs in such unsuitable applications.

No part of this publication may be reproduced, stored in a retrieval system, transmitted, or translated in any form or by any means, electronic, mechanical, manual, optical, or otherwise, without the prior written permission of ESS Technology, Inc. ESS Technology, Inc. makes no representations or warranties regarding the content of this document. All specifications are subject to change without prior notice. ESS Technology, Inc. assumes no responsibility for any errors contained herein. U.S. patents pending.

X-ON Electronics

Largest Supplier of Electrical and Electronic Components

Click to view similar products for [Audio D/A Converter ICs](#) category:

Click to view products by [ESS Tech](#) manufacturer:

Other Similar products are found below :

[106100](#) [AD1955ARSZRL](#) [AK4191EQ](#) [AK4332ECB](#) [AK4333ECB](#) [AK4432VT](#) [AK4452VN](#) [AK4458VN](#) [AK4493SEQ](#) [AK4499EXEQ](#)
[BD34301EKV-E2](#) [BD34302EKV-E2](#) [CS43131-CNZ](#) [CS43198-CNZ](#) [CS43198-CNZR](#) [CS4334-KSZ](#) [CS4335-KSZ](#) [CS4338-KSZ](#) [CS4344-DZZ](#) [CS4344-DZZR](#) [CS4345-CZZ](#) [CS4345-DZZ](#) [CS4350-CZZR](#) [CS4350-DZZ](#) [CS4353-CNZR](#) [CS4354-CSZ](#) [CS4354-CSZR](#) [CS4361-CZZ](#) [CS4361-CZZR](#) [CS4362A-CQZ](#) [CS4382A-CQZR](#) [CS4384-CQZ](#) [CS4385-CQZR](#) [CS4398-CZZ](#) [CS4398K-CZZ](#) [CS43L22-CNZR](#)
[DSD1791DB](#) [DSD1793DB](#) [DSD1794ADB](#) [ES9010K2M](#) [ES9016K2M](#) [ES9016S](#) [ES9017S](#) [ES9018K2M](#) [ES9018S](#) [ES9020Q](#) [ES9023P](#)
[ES9026PRO](#) [ES9027SPRO](#) [ES9028PRO](#)