

18V, 4A, High Efficiency Synchronous Step-Down Converter in SOT563

DESCRIPTION

ETA1654 is a wide input range, high efficiency and high frequency DC to DC step-down switching regulator, capable of delivering up to 4A of output current.

It adopts an Adaptive COT control scheme that enables very fast transient response and provides a very smooth transition when the output varies from light load to heavy load. During light load, ETA1654 goes into a PFM mode that saves switching loss achieving high efficiency. The adaptive COT control also maintains a constant switching frequency across line and load. An OVP function protects the IC itself and its downstream system against input voltage surges.

ETA1654 is available in a tiny SOT563 package.

FEATURES

- ◆ Wide Input Range: 4.5V-18V
- ◆ Adaptive COT Control
- ◆ Ultra-Fast Load Transient Response
- ◆ High Efficiency PFM Mode at Light Load
- ◆ Low Rdson Internal Power FETs
- ◆ Capable of Delivering up to 4A
- ◆ Thermal Shutdown and UVLO
- ◆ Available in SOT563

APPLICATIONS

- ◆ 5G CPE
- ◆ Set Top Box
- ◆ LCD TV

TYPICAL APPLICATION

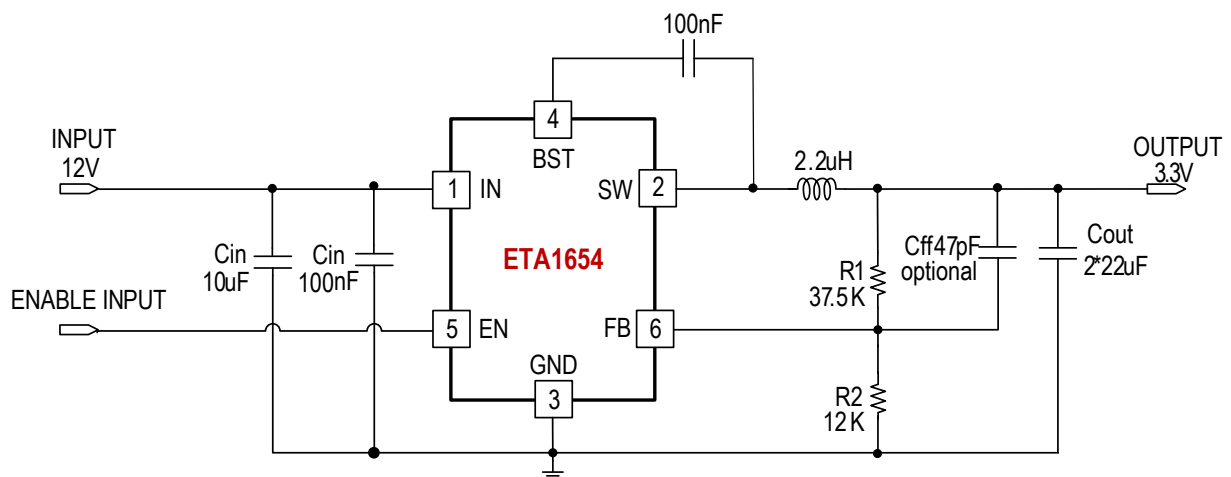

ORDERING

INFORMATION

PART No.	PACKAGE	TOP MARK	Pcs/Reel
ETA1654FSG	FCSOT563	TDYW	5000

PIN CONFIGURATION

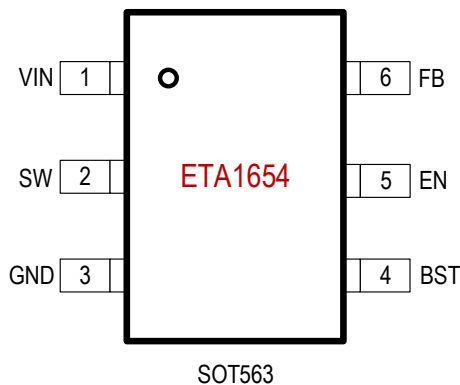

ABSOLUTE MAXIMUM RATINGS

(Note: Exceeding these limits may damage the device. Exposure to absolute maximum rating conditions for long periods may affect device reliability.)

IN, SW, EN Voltage	-0.3V to 19V
BST Voltage.....	-0.3V to SW+6V
FB Voltage	-0.3V to 6V
Operating Temperature Range	-40°C to 85°C
Storage Temperature Range	-55°C to 150°C
Thermal Resistance	θ_{JA} θ_{JC}
SOT563.....	130.....60..... °C /W
Lead Temperature (Soldering, 10 sec).....	260°C

ELECTRICAL CHARACTERISTICS

(VIN = 12V, VOUT = 3.3V, unless otherwise specified. Typical values are at TA = 25°C.)

PARAMETER	CONDITIONS	MIN	TYP	MAX	UNIT
Input Supply Range		4.5		18	V
Input Under Voltage Lock Output	V _{IN} Rising		4.05		V
UVLO Hysteresis	V _{IN} Falling		300		mV
IN Over Voltage Protection Threshold	V _{IN} Rising		19		V
OVP Hysteresis	V _{IN} Falling		0.9		V
Quiescent Current	EN = 2V		230		µA
Shutdown Current	EN = 0V		7	17	µA
FB Pin Regulation Voltage			0.805		V
FB Input Current			0	1	µA
Switching Frequency			600		KHz
Maximum Duty Cycle			97		%
Short Circuit Hiccup Time	On Time		2		ms
	Off Time		6		ms
FB out-of Hiccup Threshold	V _{OUT} rising		75		%
FB under voltage hysteresis	V _{OUT} falling		50		mV
High Side Switch On Resistance	ISW=1A		68		mΩ
Low Side Switch On Resistance	ISW=1A		32		mΩ
SW Leakage Current	V _{IN} =V _{SW} =12V			10	µA
Peak inductor protection current	High Side ON		8.8		A
Lowside current limit protection			5		A
Reverse Current Protection			200		mA
EN Rising Threshold			1.15		V
EN Threshold Hysteresis			100		mV
EN Input Current			2	6	µA

PARAMETER	CONDITIONS	MIN	TYP	MAX	UNIT
Thermal Shutdown			155		°C
Thermal Hysteresis			40		°C

PIN DESCRIPTION

PIN #	PIN NAME	DESCRIPTION
1	IN	Supply Voltage. Bypass with a 100nF HF filter plus a 10μF ceramic capacitor to GND
2	SW	Inductor Connection. Connect an inductor Between SW and the regulator output.
3	GND	Ground
4	BST	Bootstrap pin. Connect a 100nF capacitor from this pin to SW
5	EN	Enable pin for the IC. Drive this pin high to enable the part, low or floating to disable.
6	FB	Feedback Input. Connect an external resistor divider from the output to FB and GND to set VOUT.

FUNCTIONAL BLOCK DIAGRAM

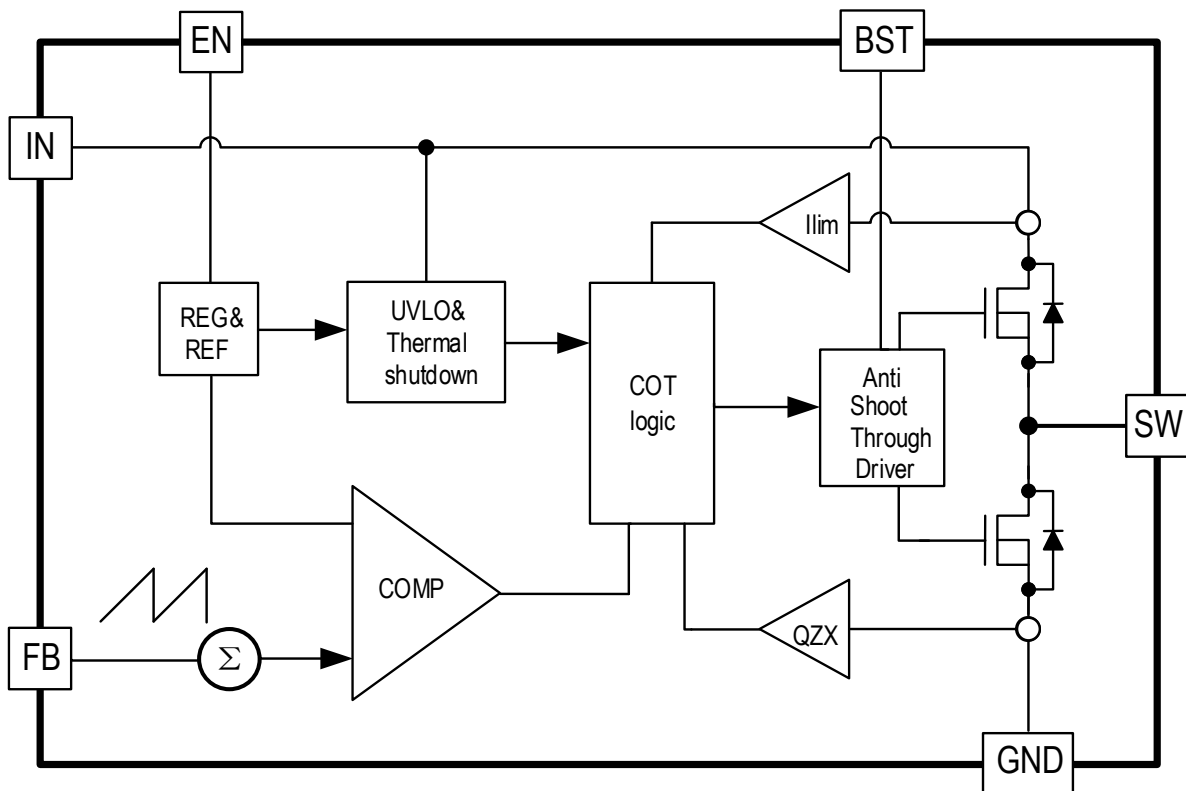

TYPICAL CHARACTERISTICS

Typical values are at $T_a=25^{\circ}\text{C}$ unless otherwise specified

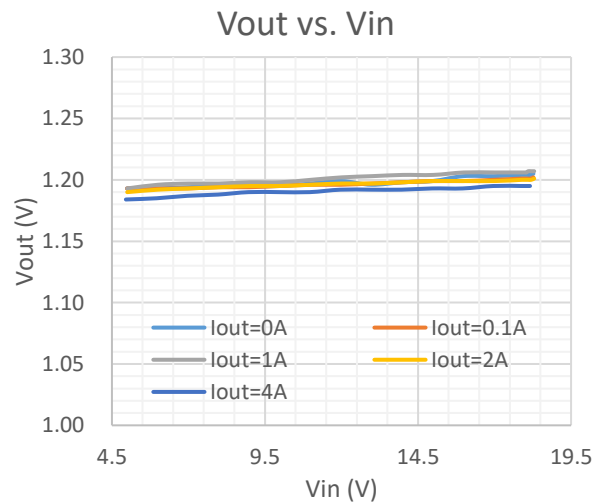
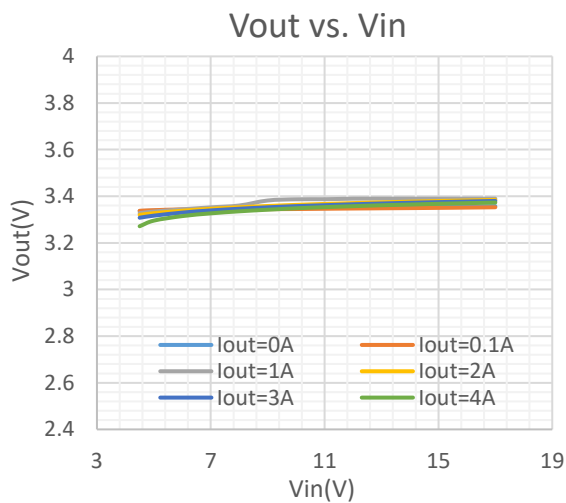
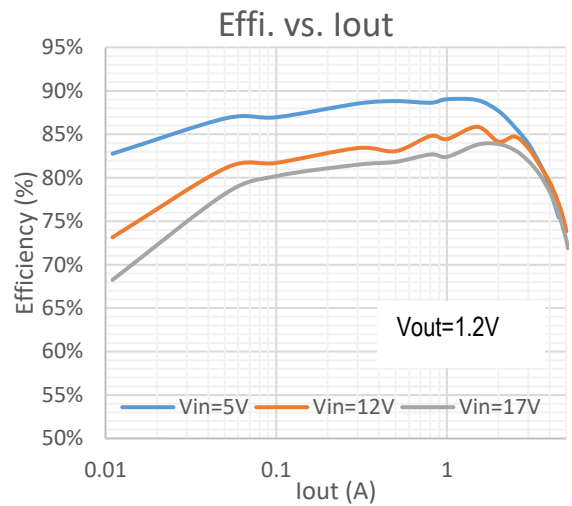
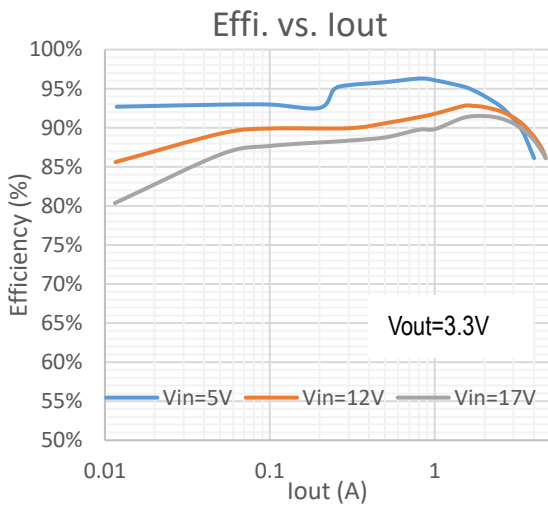
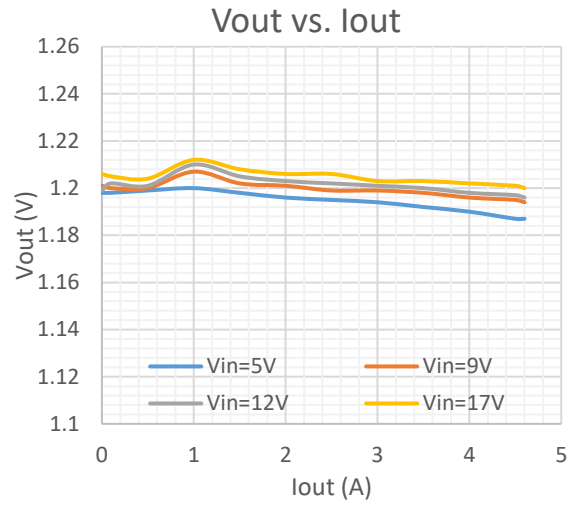
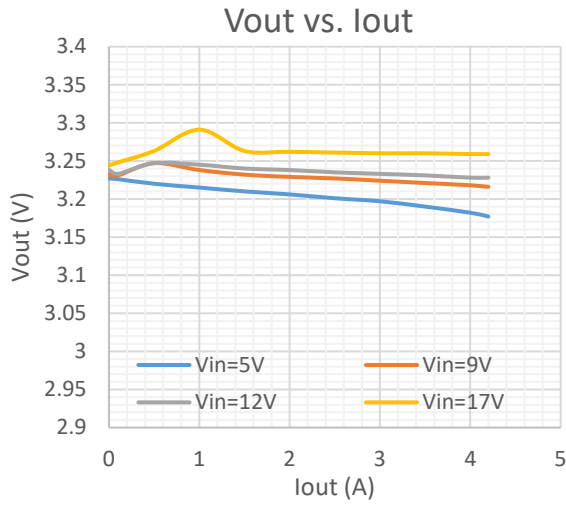

TYPICAL CHARACTERISTICS cont'd

Typical values are at $T_a=25^{\circ}\text{C}$ unless otherwise specified

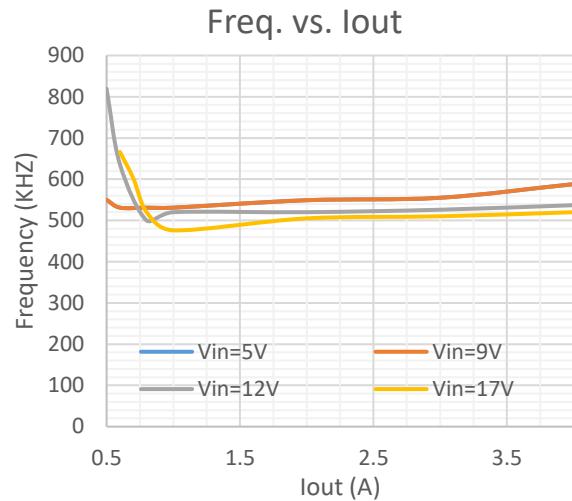
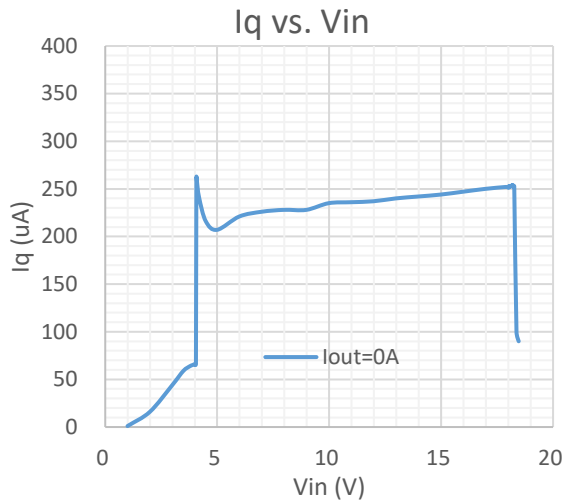

Vout=3.3V; Iout from 1A to 4A

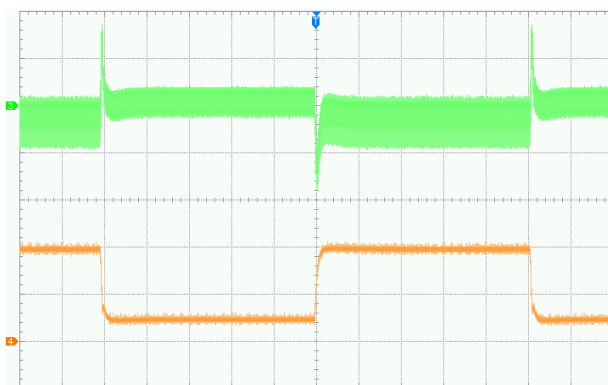

50mV/div 2A/div

Vout=1.2V; Iout from 1A to 4A

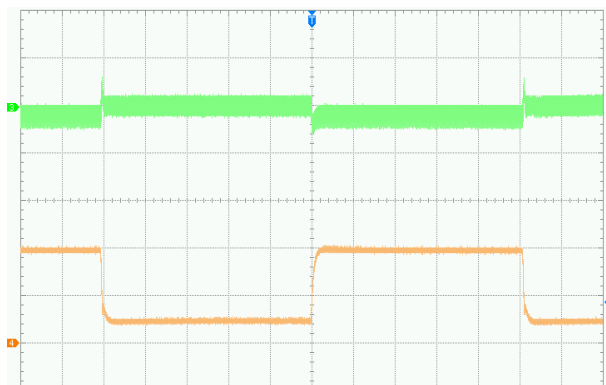

50mV/div 2A/div

FEATURE DESCRIPTION

The ETA1654 is a synchronous buck regulator ICs that integrates the adaptive COT control, top and bottom switches on the same die to minimize the switching transition loss and conduction loss.

ETA1654 is a wide input range, high-efficiency and high frequency DC-to-DC step-down switching regulator, capable of delivering up to 4A of output current. It adopts an Adaptive COT control scheme that enables very fast transient response and provides a very smooth transition when the output varies from light load to heavy load. It compares the sum of the FB voltage and a ripple voltage that mimics the voltage due to the output ESR and capacitance. The constant-on-time timer varies with line to achieve relative constant switching frequency across line.

Light Load Operation

Traditionally, a fixed constant frequency PWM DC-DC regulator always switches even when the output load is small. When energy is shuffling back and forth through the power MOSFET, power is lost due to the finite R_{dson} of the MOSFET and parasitic capacitances. At light load, this loss is prominent and efficiency is therefore very low. ETA1654 goes into a power save mode during light load, thereby extending the range of high efficiency operation.

Enable

EN is a digital control pin that turns the ETA1654 on and off. Drive EN High to turn on the regulator, drive it Low to turn it off. An internal $1M\Omega$ resistor from EN pin to GND allows EN to float to shut down the chip. Connecting the EN pin through a pull up resistor or shorted EN to IN will automatically turn on the chip whenever plug in IN.

Over Current Protection and Hiccup

ETA1654 has a cycle-by-cycle over current limit for both inductor current peak value and inductor current valley value. Meanwhile both inductor currents during LS_FET ON or HS_FET ON are monitored. During LS_FET on, sensed inductor current is monitored by a valley current limit comparator. HS_FET always wait until valley current limit disappear to be on again. Once, HS_FET is ON, it will be immediately OFF whenever max on time or peak current limit is reached.

When the output voltage drop until FB falls below UV threshold (70% V_{normal}), the ETA1654 will enter hiccup mode. It will turn off the chip immediately for 6mS. After that, it will try to re-starts as normal for 2ms. After 2ms, if FB is still below UV threshold, then the chip enters hiccup mode again. If FB is higher than UV threshold, it will enter the normal mode.

Over-Temperature Protection

Thermal protection disables the output when the junction temperature rises to approximately $150^{\circ}C$, allowing the device to cool down. When the junction temperature cools down approximately $110^{\circ}C$, the output circuitry is again enabled. Depending on power dissipation, thermal resistance, and ambient temperature, the thermal protection circuit may cycle on and off.

This cycling limits regulator dissipation, protecting the device from damage as a result of overheating.

OUTPUT VOLTAGE CONFIGURATION

In external Output Voltage Setting Version selected, the ETA1654 regulator is programmed using an external resistor divider. The output voltage is calculated using below equation.

$$V_{OUT} = V_{REF} \times \left(1 + \frac{R_1}{R_2}\right)$$

Resistor R2 has to be between 1kOhm to 20KOhm and thus R1 is calculated by following equation.

$$R_1 = \left(\frac{V_{OUT}}{V_{REF}} - 1 \right) \times R_2$$

PCB LAYOUT GUIDELINE

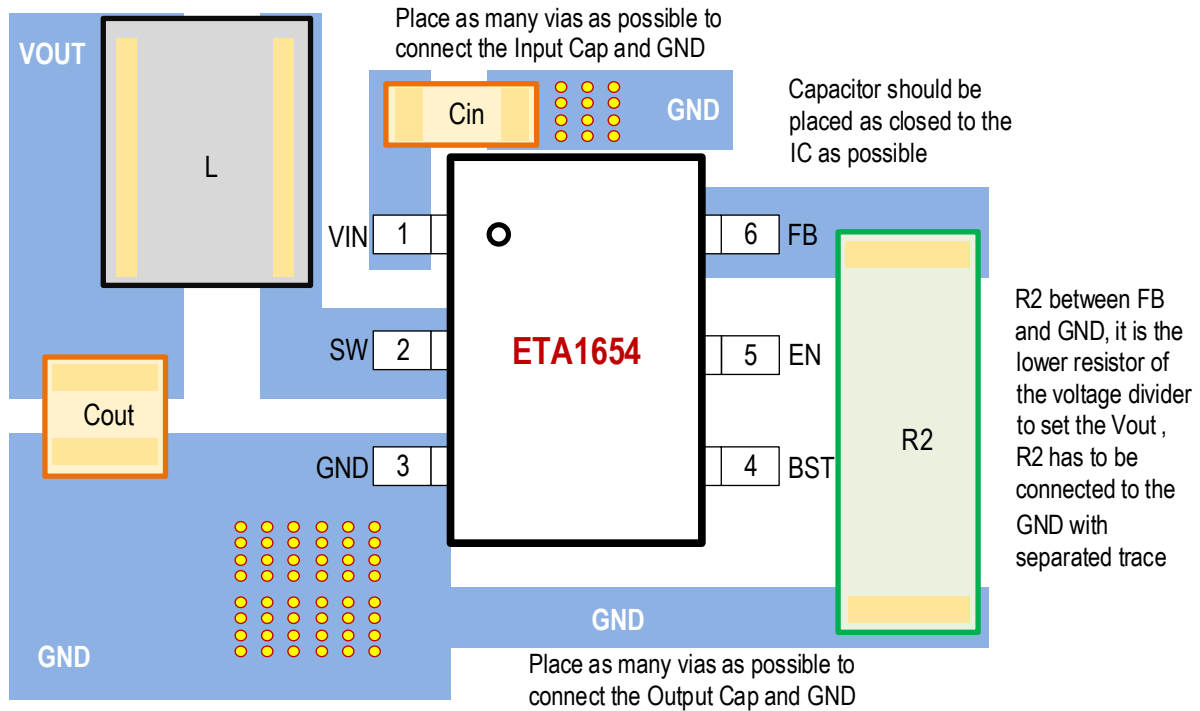

PACKAGE OUTLINE

Package: FCSOT563

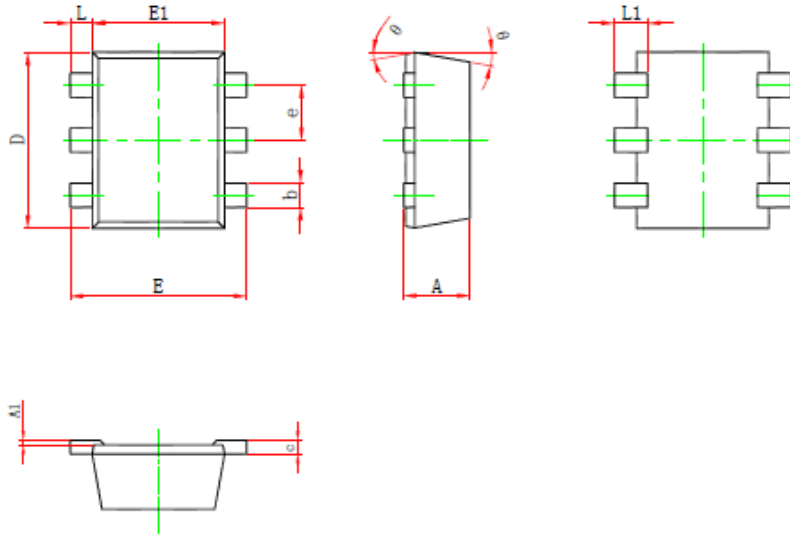

Symbol	Dimensions In Millimeters		Dimensions In Inches	
	Min.	Max.	Min.	Max.
A	0.525	0.600	0.021	0.024
A1	0.000	0.050	0.000	0.002
e	0.450	0.550	0.018	0.022
c	0.090	0.180	0.004	0.007
D	1.500	1.700	0.059	0.067
b	0.170	0.270	0.007	0.011
E1	1.100	1.300	0.043	0.051
E	1.500	1.700	0.059	0.067
L	0.100	0.300	0.004	0.012
L1	0.200	0.400	0.008	0.016
∅	9° REF.		9° REF.	

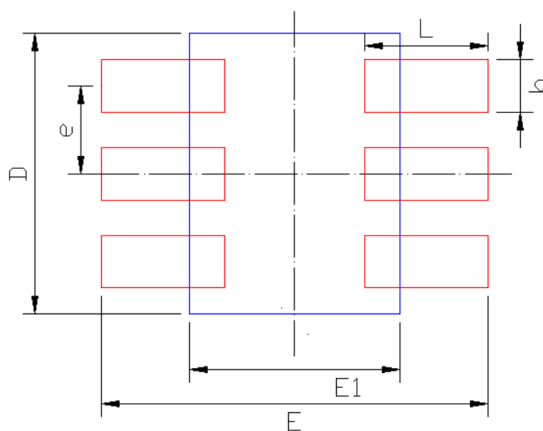

Dimensions	Value (in mm)
D	1.6
E	2.2
E1	1.2
e	0.5
b	0.3
L	0.7

RECOMMENDED LAND PATTERN

TAPE AND REEL INFORMATION

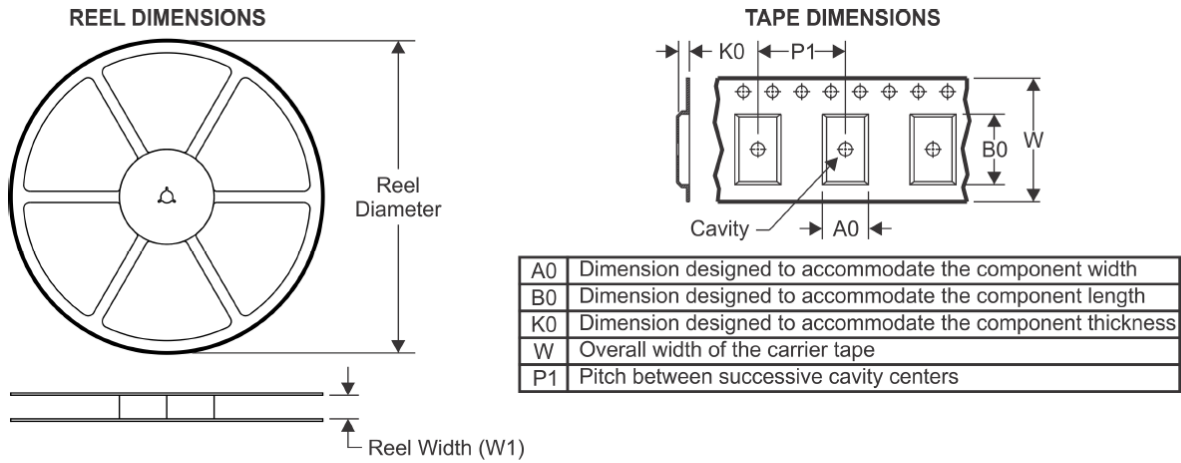

QUADRANT ASSIGNMENTS FOR PIN 1 ORIENTATION IN TAPE

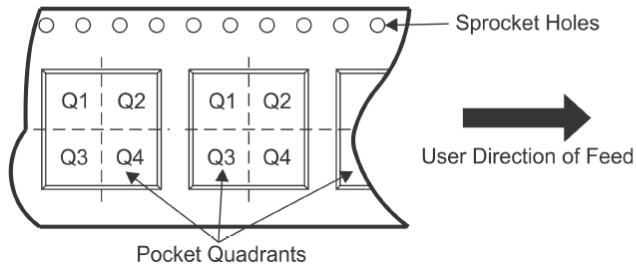

Device	Package Type	Pins	SPQ	Reel Diameter (mm)	Reel Width W1 (mm)	A0 (mm)	B0 (mm)	K0 (mm)	P1 (mm)	W (mm)	Pin1 Quadrant
ETA1654SFG	FCSOT563	6	5000	178	9.5	1.78	1.78	0.69	4	8	Q3

X-ON Electronics

Largest Supplier of Electrical and Electronic Components

Click to view similar products for [Isolated DC/DC Converters](#) category:

Click to view products by [etasolution](#) manufacturer:

Other Similar products are found below :

[PSL486-7LR](#) [Q48T30020-NBB0](#) [JAHW100Y1](#) [SPB05C-12](#) [SQ24S15033-PS0S](#) [CE-1003](#) [CE-1004](#) [MAU228](#) [J80-0041NL](#) [DFC15U48D15](#)
[XGS-1205](#) [06322](#) [SPB05B-15](#) [L-DA20](#) [DCG40-5G](#) [XKS-2405](#) [DPA423R](#) [vi-m13-cw-03](#) [VI-L53-CV](#) [24IBX15-50-0ZG](#) [HZZ01204-G](#)
[SPU02L-09](#) [SPU02M-09](#) [SPU02N-09](#) [QUINT4-BUFFER/24DC/40](#) [QUINT4-CAP/24DC/5/4KJ](#) [73-551-5039I](#) [DFC15U48D15G](#) [SEN-6471-](#)
[1EM](#) [AHV2815DF/HBB](#) [MI-LC21-IX](#) [PAH-48/8.5-D48NB1-C](#) [BM3020-7A](#) [QRS2050P025K00](#) [CM2320-9EG](#) [SKMW15F-05](#)
[V300A28H400BF3](#) [TEN 15-1223](#) [TEQ 100-2418WIR](#) [TEQ 160-7218WIR](#) [R05C05TE05S-R](#) [HQA2W085W033V-N07-S](#) [AM1SS-2405SJZ](#)
[AM2DS-1224SJZ](#) [AM2DS-2405DJZ](#) [AM10SBO-4824SNZ-B](#) [AM15E-2405S-NZ](#) [AM2DS-1212SJZ](#) [AM30SBO-4805SNZ-B](#)
[LT8301ES5#WTRPBF](#)