

1uA Ultra-Low Quiescent Current, 0.6A Output Synchronous BUCK

DESCRIPTION

The ETA3425 is a high-efficiency, DC-to-DC step-down switching regulator, capable of delivering up to 0.6A of output current. It has an ultra-low quiescent current 1uA when there is no load. Running at a fixed frequency of 1.4MHz allows the use of small inductance value and low DCR inductors, thereby achieving higher efficiencies. Other external components, such as ceramic input and output caps, can also be small due to higher switching frequency, while maintaining exceptional low noise output voltages. Internal soft-start control circuitry reduces inrush current. Short-circuit and thermal-overload protection improves design reliability. ETA3425 is housed in a tiny SOT23-5 and DFN2x2-6 package

FEATURES

- ◆ Ultra low 1uA Iq, and 1-3uA at standby
- ◆ Up to 96% Efficiency
- ◆ Up to 600mA Max Output Current
- ◆ 1.4MHz Frequency
- ◆ Light Load operation
- ◆ Internal Compensation
- ◆ Tiny Package

APPLICATIONS

- ◆ Wearable
- ◆ IOT
- ◆ Energy Harvest
- ◆ Battery powered devices

TYPICAL APPLICATION

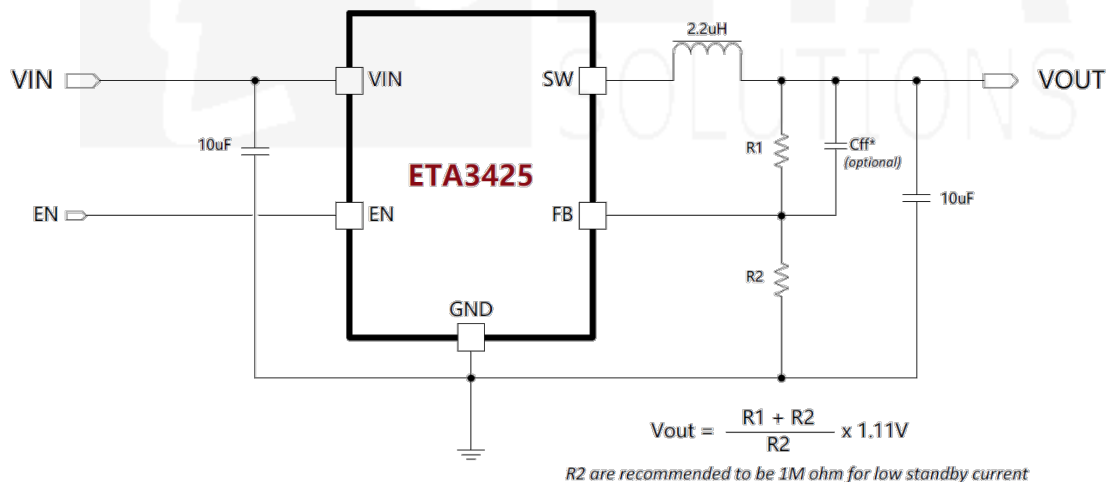

ORDERING

INFORMATION

PART No.	PACKAGE	TOP MARK	Pcs/Reel
ETA3425S2F	SOT23-5	CFYW	3000
ETA3425D2G	DFN2x2-6	CFYW	3000

PIN CONFIGURATION

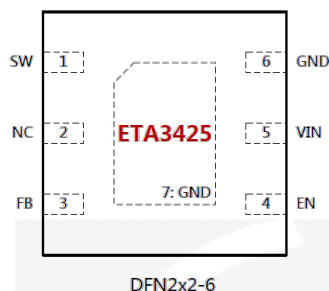
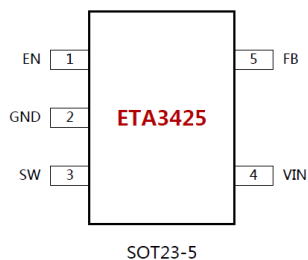

ABSOLUTE MAXIMUM RATINGS

(Note: Exceeding these limits may damage the device. Exposure to absolute maximum rating conditions for long periods may affect device reliability.)

IN, SW, OUT, EN Voltage	-0.3V to 7.5V
SW to ground current.....	Internally limited
Operating Temperature Range	-40°C to 85°C
Storage Temperature Range	-55°C to 150°C
Thermal Resistance θ_{JA} θ_{JC}	
SOT23-5.....	190.....90 °C /W
DFN2x2-6.....	165.....45 °C /W
Lead Temperature (Soldering, 10sec)	260°C
ESD HBM (Human Body Mode)	2KV
ESD MM (Machine Mode)	200V

ELECTRICAL CHARACTERISTICS

(V_{IN} = 5V, unless otherwise specified. Typical values are at T_A = 25°C.)

PARAMETER	CONDITIONS	MIN	TYP	MAX	UNITS
Input Voltage Range		2.6		7	V
Input UVLO	Rising, Hysteresis=170mV		2.25		V
Input Supply Current	No Load, RFB_G = 10Mohm		1.8	3	μ A
Input Shutdown Current			0.1		μ A
FB Voltage		1.094	1.11	1.126	V
Load Regulation			0.4		%/A
Line Regulation	V_{IN} = 2.7 to 5.5V		0.14		%/V
Switching Frequency		0.8	1.4	2	MHz
NMOS Switch On Resistance	I_{SW} = 200mA		200		m Ω
PMOS Switch On Resistance	I_{SW} = 200mA		300		m Ω
PMOS Switch Current Limit			1		A
Soft-Start Time			120		μ s
SW Leakage Current	V_{OUT} =7V, V_{SW} =0 or 7V, EN= GND			1	μ A
EN Input Current	EN= GND			1	μ A
EN Input Low Voltage				0.4	V
EN Input High Voltage		1.0			V

PIN DESCRIPTION

SOT23-5 PIN #	DFN2x2-6 PIN #	NAME	DESCRIPTION
1	4	EN	Enable Pin. Pull high to enable, pull low to disable.
2	6, 7	GND	Ground
3	1	SW	Inductor Connection. Connect a 2.2uH inductor Between SW and the regulator output.
4	5	VIN	Supply Voltage. Short to PIN. Bypass with a 10μF ceramic capacitor to GND
5	3	FB	FB Voltage Pin. Connect an external resistor divider from the output to FB and GND to set the output to a voltage between 1.11V and VIN
	2	NC	Not Connected

FUNCTIONAL BLOCK DIAGRAM

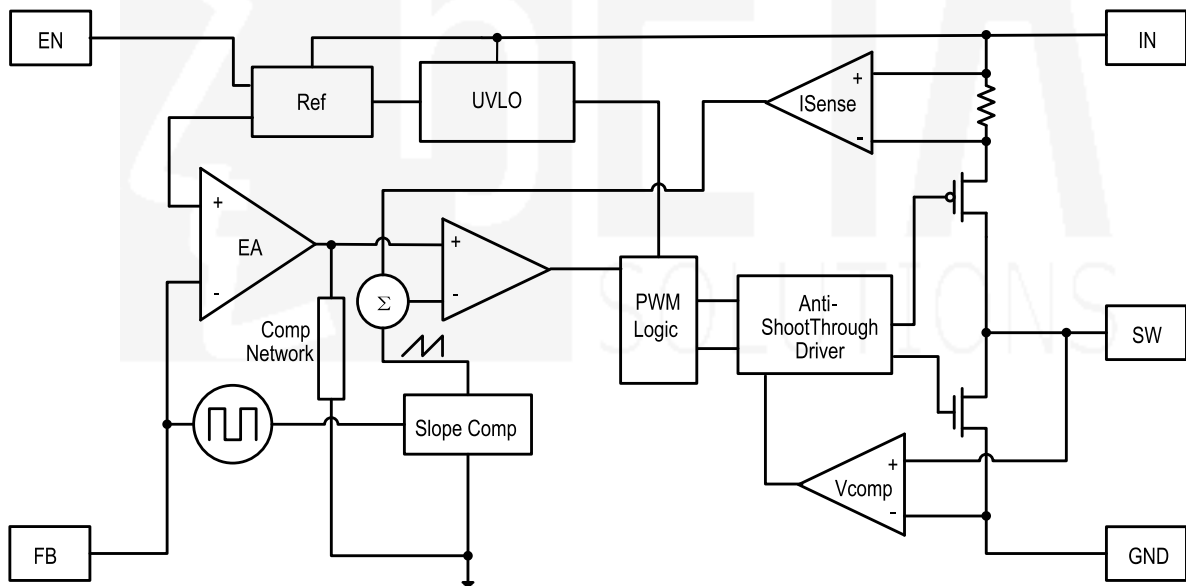

TYPICAL CHARACTERISTICS

(Typical values are at $T_A = 25^\circ\text{C}$ unless otherwise specified.)

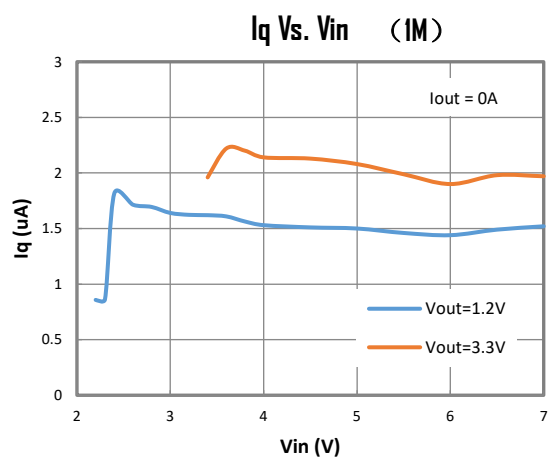
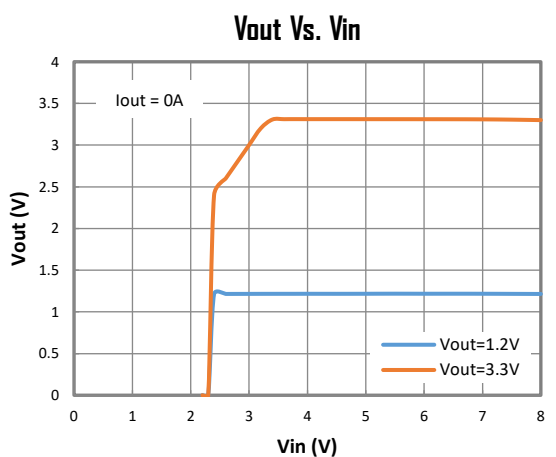
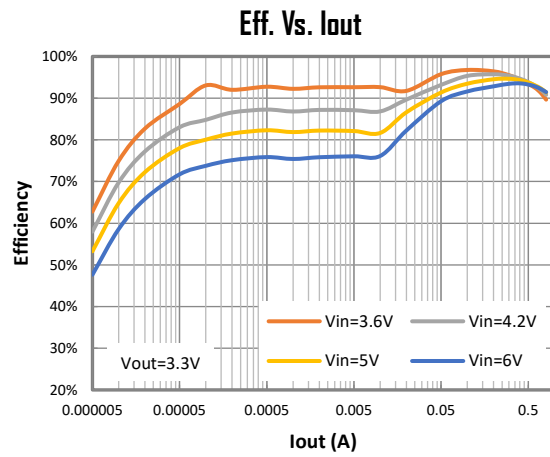
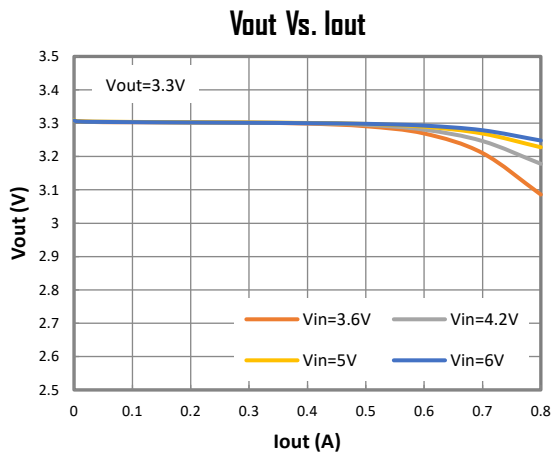
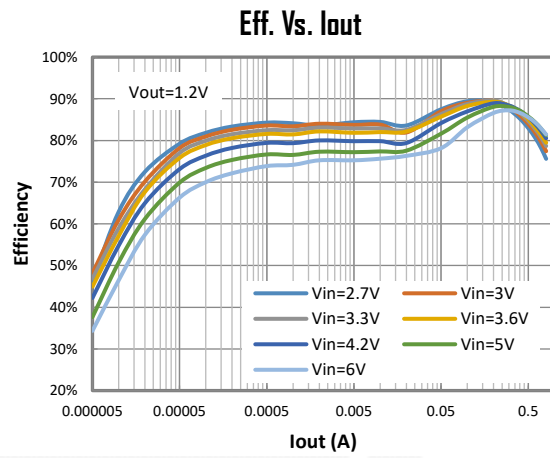
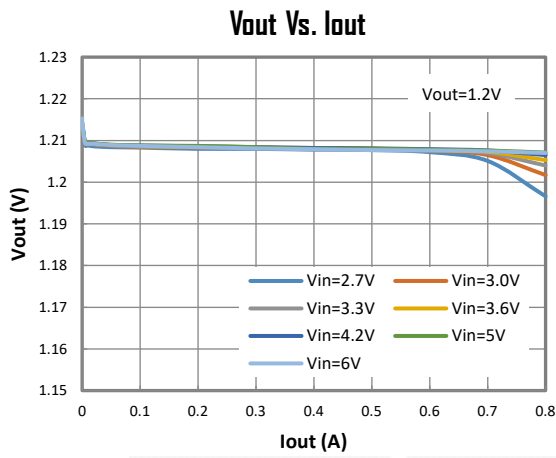

TYPICAL CHARACTERISTICS Cont'd

(Typical values are at $T_A = 25^\circ\text{C}$ unless otherwise specified.)

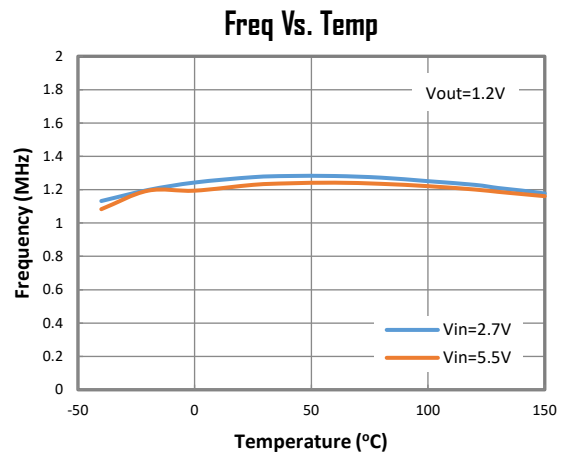
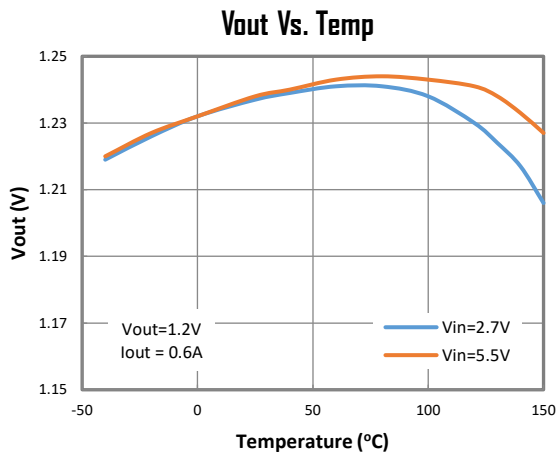

PCB GUIDELINES

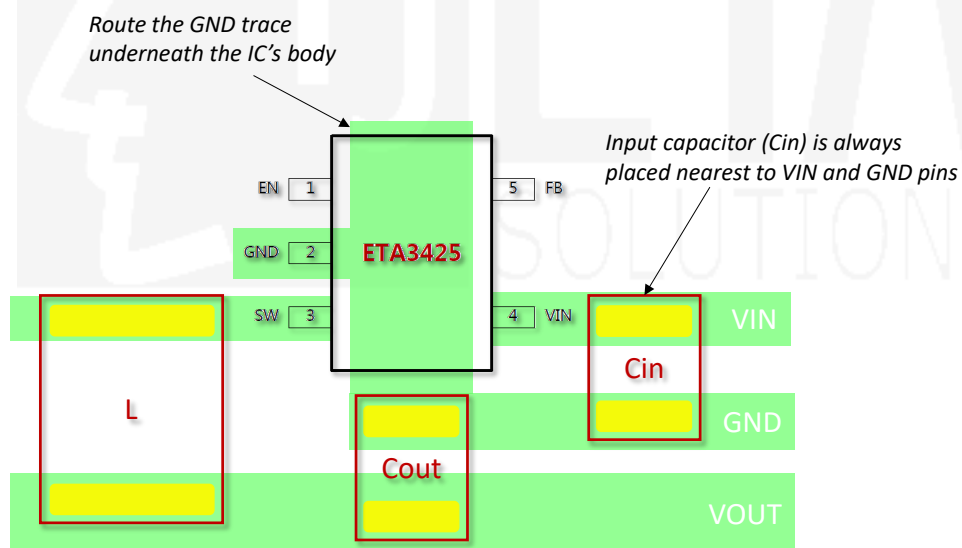

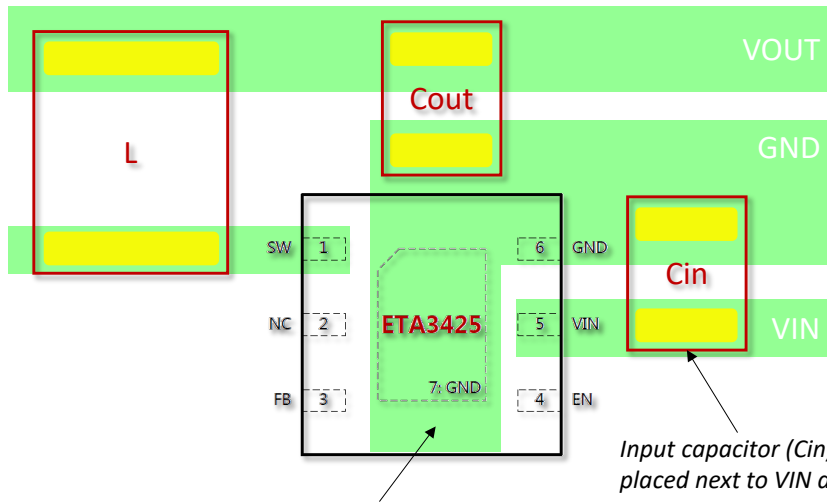

Pin 6 and 7 must be connected to ground together

Input capacitor (Cin) is always placed next to VIN and GND pins

PACKAGE OUTLINE

Package: SOT23-5

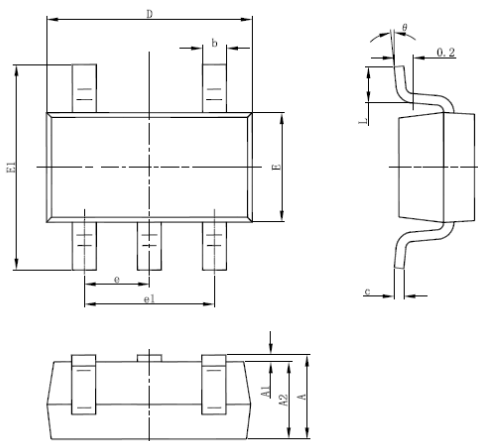

Symbol	Dimensions In Millimeters		Dimensions In Inches	
	Min	Max	Min	Max
A	1.050	1.250	0.041	0.049
A1	0.000	0.100	0.000	0.004
A2	1.050	1.150	0.041	0.045
b	0.300	0.500	0.012	0.020
c	0.100	0.200	0.004	0.008
D	2.820	3.020	0.111	0.119
E	1.500	1.700	0.059	0.067
E1	2.650	2.950	0.104	0.116
e	0.950(BSC)		0.037(BSC)	
e1	1.800	2.000	0.071	0.079
L	0.300	0.600	0.012	0.024
θ	0°	8°	0°	8°

Package: DFN2x2-6

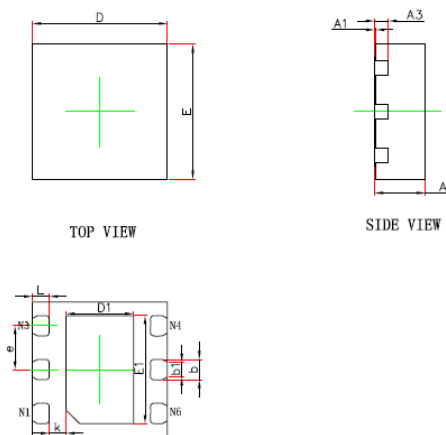

Symbol	Dimensions In Millimeters		Dimensions In Inches	
	Min.	Max.	Min.	Max.
A	0.700	0.800	0.028	0.031
A1	0.000	0.050	0.000	0.002
A3	0.203REF.		0.008REF.	
D	1.900	2.100	0.075	0.083
E	1.900	2.100	0.075	0.083
D1	0.900	1.100	0.035	0.043
E1	1.500	1.700	0.059	0.067
k	0.250 REF.		0.010REF.	
b	0.250	0.350	0.010	0.014
b1	0.220 REF.		0.009 REF.	
e	0.650BSC.		0.026BSC.	
L	0.174	0.326	0.007	0.013

X-ON Electronics

Largest Supplier of Electrical and Electronic Components

Click to view similar products for [Isolated DC/DC Converters](#) category:

Click to view products by [etasolution](#) manufacturer:

Other Similar products are found below :

[PSL486-7LR](#) [Q48T30020-NBB0](#) [JAHW100Y1](#) [SPB05C-12](#) [SQ24S15033-PS0S](#) [CE-1003](#) [CE-1004](#) [MAU228](#) [J80-0041NL](#) [DFC15U48D15](#)
[XGS-1205](#) [06322](#) [SPB05B-15](#) [L-DA20](#) [DCG40-5G](#) [XKS-2405](#) [DPA423R](#) [vi-m13-cw-03](#) [VI-L53-CV](#) [24IBX15-50-0ZG](#) [HZZ01204-G](#)
[SPU02L-09](#) [SPU02M-09](#) [SPU02N-09](#) [QUINT4-BUFFER/24DC/40](#) [QUINT4-CAP/24DC/5/4KJ](#) [73-551-5039I](#) [DFC15U48D15G](#) [SEN-6471-](#)
[1EM](#) [AHV2815DF/HBB](#) [MI-LC21-IX](#) [PAH-48/8.5-D48NB1-C](#) [BM3020-7A](#) [QRS2050P025K00](#) [CM2320-9EG](#) [SKMW15F-05](#)
[V300A28H400BF3](#) [TEN 15-1223](#) [TEQ 100-2418WIR](#) [TEQ 160-7218WIR](#) [R05C05TE05S-R](#) [HQA2W085W033V-N07-S](#) [AM1SS-2405SJZ](#)
[AM2DS-1224SJZ](#) [AM2DS-2405DJZ](#) [AM10SBO-4824SNZ-B](#) [AM15E-2405S-NZ](#) [AM2DS-1212SJZ](#) [AM30SBO-4805SNZ-B](#)
[LT8301ES5#WTRPBF](#)