

## 1.2A/16V Fully Integrated Linear Charger for 1 Cell Li-ion Battery

### DESCRIPTION

ETA4056 is a single cell, fully integrated constant current (CC)/constant voltage (CV) Li-ion battery charger. Its compact package with minimum external components requirement makes the ETA4056 ideal for portable applications. No external sense resistor or blocking diode is necessary for the ETA4056. Build-in thermal feedback mechanism regulates the charge current to control the die temperature during high power operation or at elevated ambient temperature. The ETA4056 has a pre-charge function for trickle charging deeply discharged batteries. The fast charge current can be programmed by an external resistor. CV regulation mode is automatically enabled once the battery's charging curve reaches the constant voltage portion. The output current then decays and is finally terminated once the charge current drops to 1/10th of the programmed value. The ETA4056 keeps monitoring the battery voltage and enables a new charge cycle once the voltage drops by 120mV below the CV value.

ETA4056 is in an ESOP8, DFN2x2-8, DFN2x3-8, and SOT23-6 package.

### FEATURES

- ◆ 16V input standoff voltage
- ◆ 4.2V charge termination voltage
- ◆ 2.9V trickle charge threshold
- ◆ Charge current programmable, up to 1.2A
- ◆ 250nA BAT current when no charging
- ◆ Soft-start limits in-rush current
- ◆ ESOP8 / DFN2x2-8 / DFN2x3-8 / SOT23-6

### APPLICATIONS

- ◆ E-cigarette
- ◆ Toys
- ◆ Bluetooth applications
- ◆ Li-ion battery powered devices

### TYPICAL APPLICATION

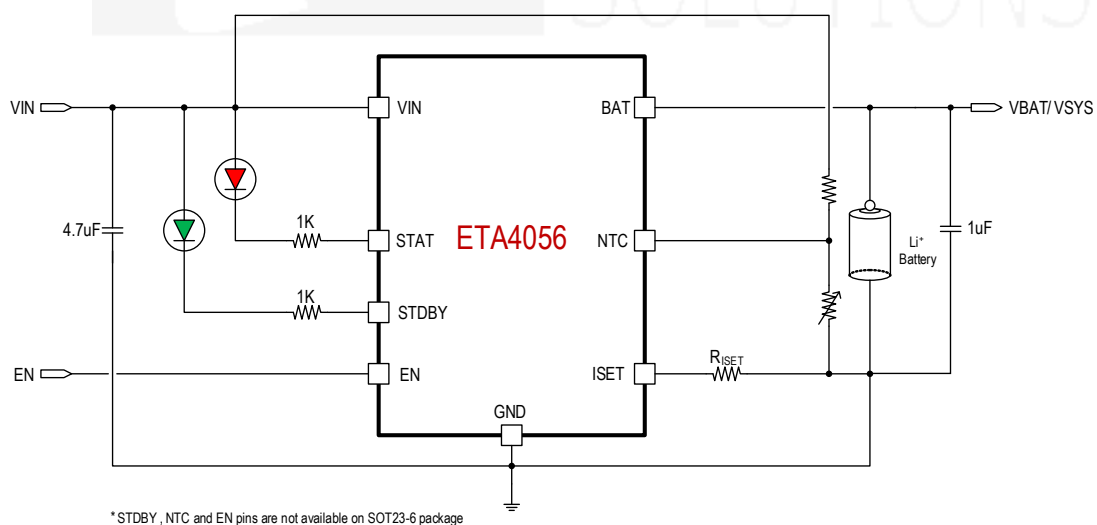

## ORDERING INFORMATION

PART No.	PACKAGE	TOP MARK	Pcs/Reel
ETA4056E8A	ESOP8	ETA4056 YWW2L	4000
ETA4056D2I	DFN2x2-8	ELYW	3000
ETA4056D6I	DFN2x3-8	ELYW	3000
ETA4056S2G	SOT23-6	B1YW	3000

## PIN CONFIGURATION

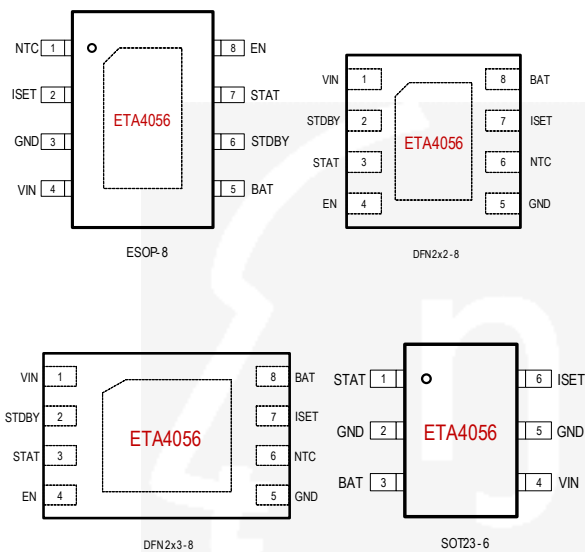

## ABSOLUTE MAXIMUM RATINGS

(Note: Exceeding these limits may damage the device. Exposure to absolute maximum rating conditions for long periods may affect device reliability.)

VIN Voltage	-0.3V to 20V	
ISET Voltage	-0.3V to 6V	
All other pin Voltage	-0.3V to 16V	
Operating Temperature Range	-40°C to 85°C	
Storage Temperature Range	-55°C to 150°C	
Thermal Resistance	$\theta_{JC}$	$\theta_{JA}$
ESOP8	10	50
DFN2x2-8	20	100
DFN2x3-8	15	80
SOT23-6	22	110
Lead Temperature (Soldering, 10sec)	260°C	
ESD HBM (Human Body Mode)	2KV	

## ELECTRICAL CHARACTERISTICS

(VIN = 5V, unless otherwise specified. Typical values are at TA = 25°C.)

PARAMETER	CONDITIONS	MIN	TYP	MAX	UNITS
Input Standoff Voltage		16			V
Input Over-Voltage Protection Voltage	VIN rising, hys=0.3V	6.5	7	7.4	V
Input Voltage Range for Charging		4.25		6	V
Input Supply Current	Charge Mode		300	2000	$\mu$ A
	Standby Mode (Charge Terminated)		65	100	$\mu$ A
	Shutdown Mode (ISET Not Connected, EN=0, VIN<VBAT, or VIN<VULO)		25	50	$\mu$ A
Regulated Output (Float) Voltage	Riset = 10K, IBAT = 40mA	4.16	4.2	4.24	V
BAT Pin Current	Riset = 10K, Current Mode	90	100	110	mA
	Riset = 2K, Current Mode	432	480	528	mA

PARAMETER	CONDITIONS	MIN	TYP	MAX	UNITS
	Riset = 1K, Current Mode	820	920	1020	mA
	Standby Mode, VBAT = 4.2V From battery to BAT Pin		2	3	μA
	Shutdown Mode, ISET Not Connected From battery to BAT Pin	0	0.25	0.35	μA
	Sleep Mode, VIN = 0V From battery to BAT Pin	0	0.25	0.35	μA
Trickle Charge Current	VBAT < VTRIKL, Rset = 2K	20	50	110	mA
Trickle Charge Threshold Voltage	VBAT Rising	2.75	2.93	3.1	V
Trickle Charge Hysteresis Voltage		100	130	165	mV
VIN Under-voltage Lockout Threshold	From VIN Low to High	3.05	3.35	3.6	V
VIN Under-voltage Lockout Hysteresis		0.4	0.55	0.65	V
EN Pull-Up Current		0.5	1		μA
Enable Charger	EN Pin Rising	1.6			V
Disable Charger	EN Pin Falling			0.6	V
VIN-VBAT Lockout Threshold Voltage	VIN from Low to High	50	100	140	mV
	VIN from High to Low	5	30		mV
C/10 Termination Current Threshold		0.085	0.1	0.115	mA/mA
ISET Pin Voltage	Current Mode, VBAT=4V		1		V
STAT/STDBY Pin Weak Pull-Down Current	V_STAT = 5V		0.1		μA
STAT/STDBY Pin Output Low Voltage	I_STAT or I_STDBY= 5mA		0.35	0.6	V
Recharge BAT Threshold Voltage	VFLOAT - VRECHRG	90	120	150	mV
Junction Temperature in Constant Temperature Mode			120		°C
Power FET "ON" Resistance (Between VCC and BAT)			0.5		ohm
Soft-Start Time	IBAT=0 to IBAT=1000V/RSET		100		μs
Termination Comparator Filter Time	IBAT Falling Below ICHG/10	400	1000	2500	μs
ISET Pin Pull-Up Current			1		μA
NTC Threshold, Cold	Charger Suspended	77	80	81	% VIN
NTC Threshold, Hot	Charger Suspended	43	45	46.5	% VIN
NTC Threshold Hysteresis			2		% VIN
NTC Disable Threshold	Tie NTC to GND				
NTC Input Leakage			0	1	μA

## PIN DESCRIPTION

ESOP8 PIN #	DFN2x2-8 PIN#	DFN2x3-8 PIN#	SOT23-6 PIN#	NAME	DESCRIPTION
1	6	6	NA	NTC	Battery Temperature Monitoring input pin. It sets the valid temperature operating range for both battery charging and discharging.
2	7	7	6	ISET	<p>Program, Monitor the charge current and Shutdown. This pin set to 1V in constant-current mode. The charge current is programmed by connecting a 1% resistor (Rset), between ISET, to GND pin. The charge current can be calculated using the following formula:</p> $I_{BAT} = \frac{1}{R_{set}} \times 1000 - \left( \frac{1}{3.6} \times \frac{1}{R_{set}} \times 1000 \right)^2$ <p>The ISET pin can also be used to switch the charger to shutdown mode by disconnecting the program resistor from ground.</p>
3	5	5	2	GND	Ground.
4	1	1	4	VIN	Positive Input Supply. Needs to be bypassed with at least a 4.7μF capacitor.
5	8	8	3	BAT	Charge Current Output. This pin provides charge current to the battery and regulates the final float voltage to 4.2V which is set by an internal precision resistor divider.
6	2	2	NA	STDBY	Open-Drain Output for Charge Finished flag. The STDBY pin outputs low when the battery is finished charging. When in the status of charging, it becomes high-impedance.
7	3	3	1	STAT	Open-Drain Output for In Charging flag, The STAT pin outputs low when the battery is in charging. Upon the completion of the charge cycle, it becomes high-impedance.
8	4	4	NA	EN	Enable the IC charger or not. Drive this pin high or floating to enable charger, low to disable.

## FUNCTION BLOCK DIAGRAM

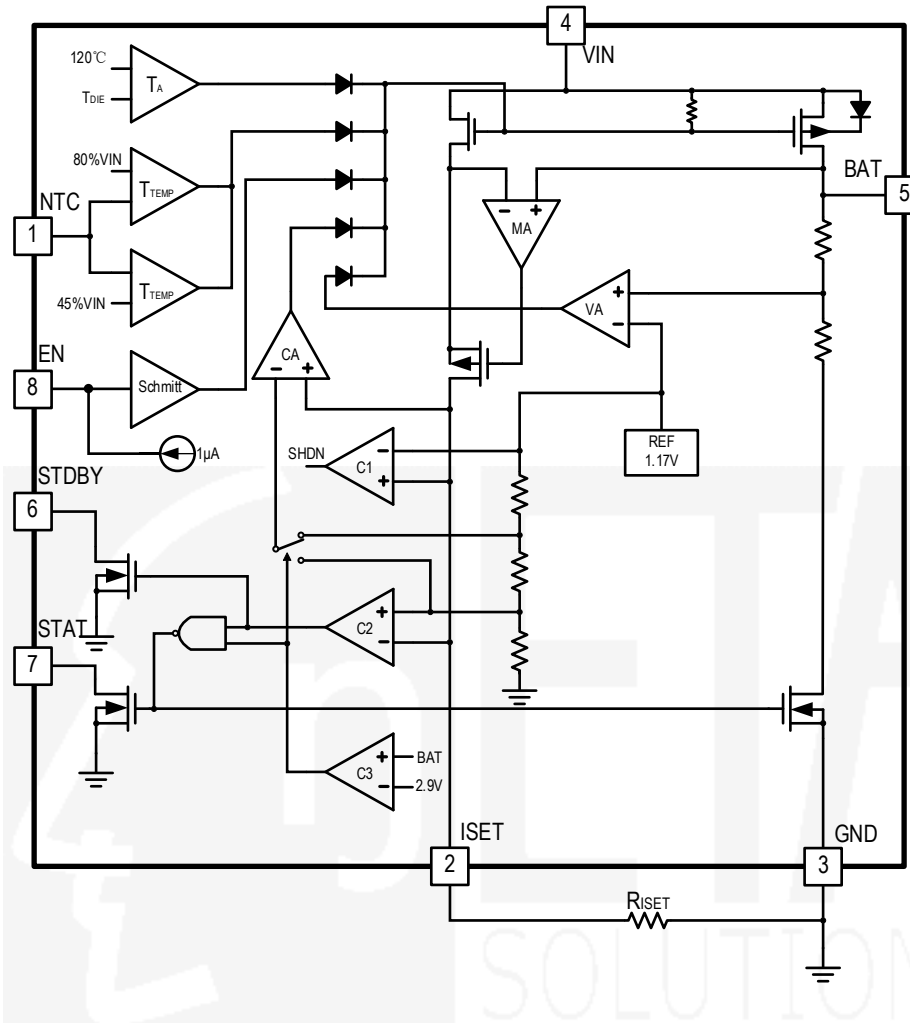

## FUNCTIONAL DESCRIPTIONS

The ETA4056 is a single cell, fully integrated constant current (CC)/constant voltage (CV) Li-ion battery charger. It can deliver up to 1200mA of charge current with a final float voltage accuracy of 1%. The ETA4056 has a built-in thermal regulation circuitry that ensures its safe operation. No blocking diode or external current sense resistor is required; hence reduce the external components for a basic charger circuit to two. The ETA4056 is also capable of operating from a USB power source.

*Normal Charge Cycle*

The ETA4056 initiates a charge cycle once the voltage at the VIN pin rises above the UVLO threshold level. A 1% precision resistor needs to be connected from the ISET pin to ground. If the voltage at the BAT pin is less than 2.9V, the charger enters trickle charge mode. In this mode, the charge current is reduced to nearly 1/10 the programmed value until the battery voltage is raised to a safe level for full current charging.

The charger switches to constant-current mode as the BAT pin voltage rises above 2.9V, the charge current is thus

resumed to full programmed value. When the final float voltage (4.2V) is reached, the ETA4056 enters constant-voltage mode and the charge current begins to decrease until it drops to 1/10 of the preset value and ends the charge cycle.

### Programming Charge Current

The charge current is programmable by setting the value of a precision resistor connected from the ISET pin to ground. The charge current is 1000 times of the current out of the ISET pin. The charge current out of the BAT pin can be determined at any time by monitoring the ISET pin voltage using the following equation:

$$I_{BAT} = \frac{1}{R_{set}} \times 1000 - \left( \frac{1}{3.6} \times \frac{1}{R_{set}} \times 1000 \right)^2$$

### Charge Termination

The ETA4056 keeps monitoring the ISET pin during the charging process. It terminates the charge cycle when the charge current falls to 1/10 the programmed value after the final float voltage is reached. When the ISET pin voltage falls below 100mV for longer than tTERM (typically 1ms), charging is terminated. The charge current is latched off and the ETA4056 enters standby mode, where the input supply current drops to 200µA. (Note: C/10 termination is disabled in trickle charging and thermal limiting modes).

During charging, the transient response of the circuit can cause the ISET pin to fall below 100mV temporarily before the battery is fully charged, thus can cause a premature termination of the charge cycle. A 1ms filter time on the termination comparator can prevent this from happening. Once the average charge current drops below 1/10 the programmed value, the ETA4056 terminates the charge cycle and ceases to provide any current through the BAT pin. In this state, all loads on the BAT pin must be supplied by the battery.

The ETA4056 constantly monitors the BAT pin voltage in standby mode and resume another charge cycle if this voltage drops below the recharge threshold. User can also manually restart a charge cycle in standby mode either by removing and then reapplied the input voltage or restart the charger using the ISET pin.

### Charge Status Indicator (STAT and STDBY pin)

There are 2 different states of the charge status, one is IN CHRGING, and the other is CHARGING FINISHED. STAT is the pin to pull low during IN CHARGING status and become high impedance in CHARGING FINISHED status. And STDBY pin just works the opposite way, pulling low after charge finished, and high impedance when in charging.

Table 1:Charger Status Indication

Charger Status	STAT	STDBY
Charging	Low	Hi-Z
End of charge,ISET disable charger only	Hi-Z	Low
Vin OVP,NTC fault	Hi-Z	Hi-Z
No BAT/w BAT Pin has Cap(NTC Pin float/GND)	Blinking,(depend on Cap)	Low
No BAT/w BAT Pin has no Cap(NTC Pin float/GND)	Blinking	Hi-Z

## *High Temperature Fold-back*

Build-in feedback circuitry mechanism can reduce the value of the programmed charge current once the die temperature tends to rise above 50°C, hence prevents the temperature from further increase and ensure device safe operation.

## *Under-voltage Lockout (UVLO)*

Build-in under-voltage lockout circuit monitors the input voltage and keeps the charger in shutdown mode until VIN rises above the under-voltage lockout threshold. The UVLO circuit has a built-in hysteresis of 500mV. Furthermore, to protect against reverse current in the power MOSFET, the UVLO circuit keeps the charger in shutdown mode if VIN falls to within 30mV of the battery voltage. If the UVLO comparator is tripped, the charger will not come out of shutdown mode until VIN rises 100mV above the battery voltage.

## *Manual Shutdown*

There are two methods can disable the IC charger:

1. Driver the EN pin to low.
2. Floating the ISET pin by removing the resistor from ISET pin to ground.

Once one of above conditions happen can put the device in shutdown mode. The battery drain current is thus reduced to 250nA and the supply current to <math><50\mu\text{A}</math>. Reconnecting the resistor back or driver EN pin high will restart a new charge cycle.

## *Automatic Recharge*

After the termination of the charge cycle, the ETA4056 constantly monitors the BAT pin voltage and starts a new charge cycle when the battery voltage falls below 4.08V, keeping the battery at fully charged condition. ISET pin output enters a strong pull-down state during recharge cycles.

## *Battery Temperature Monitoring*

ETA4056 continuously monitors temperature by measuring the voltage of NTC pin. A negative or positive temperature coefficient thermistor and an external voltage divider typically develop this voltage. ETA4056 compares this voltage against its internal 80%VIN and 45%VIN thresholds to determine if charging is allowed. The temperature sensing circuit is immune to any fluctuation in VIN, since both the external voltage divider and the internal thresholds 80%VIN and 45%VIN are referenced to VIN. If the NTC pin is connected to GND will disable the temperature-sensing feature.

## PACKAGE OUTLINE

Package: ESOP8

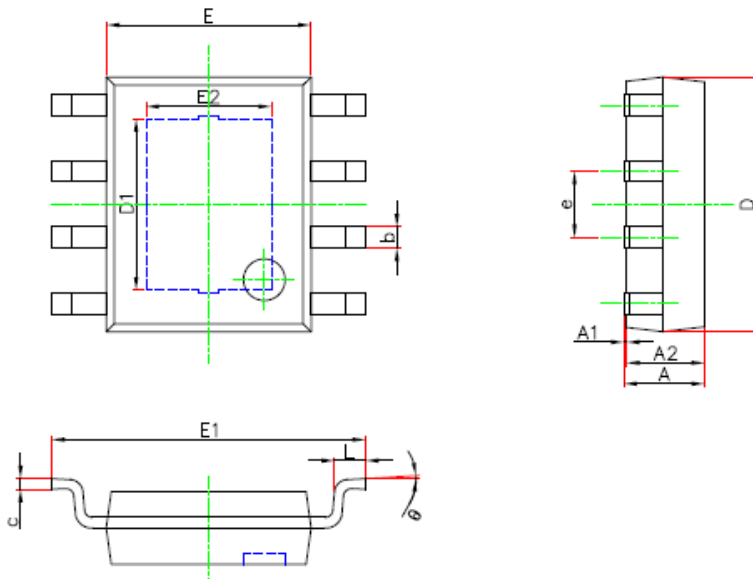

Symbol	Dimensions In Millimeters		Dimensions In Inches	
	Min.	Max.	Min.	Max.
A	1.300	1.700	0.051	0.067
A1	0.000	0.100	0.000	0.004
A2	1.350	1.550	0.053	0.061
b	0.330	0.510	0.013	0.020
c	0.170	0.250	0.007	0.010
D	4.700	5.100	0.185	0.201
D1	3.202	3.402	0.126	0.134
E	3.800	4.000	0.150	0.157
E1	5.800	6.200	0.228	0.244
E2	2.313	2.513	0.091	0.099
e	1.270(BSC)		0.050(BSC)	
L	0.400	1.270	0.016	0.050
θ	0°	8°	0°	8°

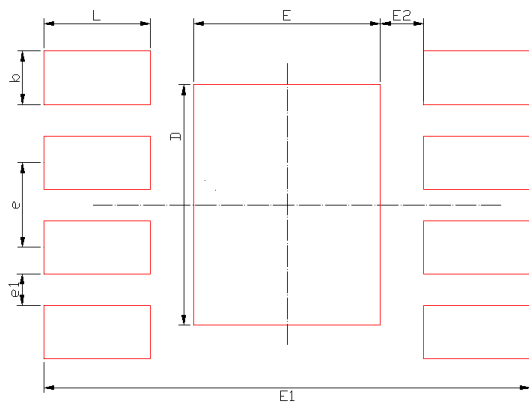

ESOP8

RECOMMENDED LAND PATTERN

Dimensions	Value (in mm)
D	3.6
E	2.8
E1	7.3
E2	0.65
b	0.8
e	1.27
e1	0.47
L	1.6



PACKAGE OUTLINE (cont')

Package: DFN2x3-8

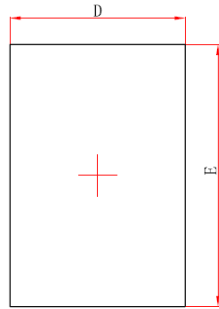

Top View

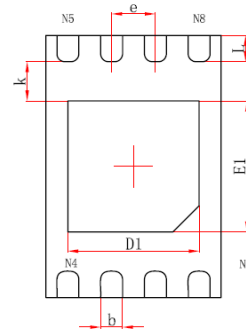

Bottom View

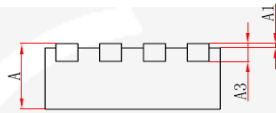

Side View

Symbol	Dimensions In Millimeters		Dimensions In Inches	
	Min.	Max.	Min.	Max.
A	0.700	0.800	0.028	0.031
A1	0.000	0.050	0.000	0.002
A3	0.203REF.		0.008REF.	
D	1.924	2.076	0.076	0.082
E	2.924	3.076	0.115	0.121
D1	1.400	1.600	0.055	0.063
E1	1.400	1.600	0.055	0.063
k	0.200MIN.		0.008MIN.	
b	0.200	0.300	0.008	0.012
e	0.500TYP.		0.020TYP.	
L	0.224	0.376	0.009	0.015

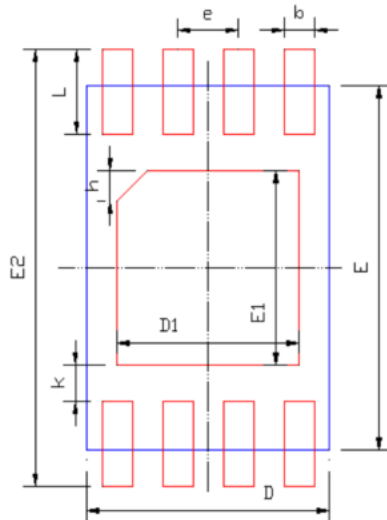

Dimensions	Value (in mm)
E	3
D	2
E1	1.6
D1	1.5
E2	3.6
b	0.25
e	0.5
L	0.7
k	0.3
h	0.25

RECOMMENDED LAND PATTERN

## PACKAGE OUTLINE (cont')

Package: DFN2x2-8

From assembly house 1:

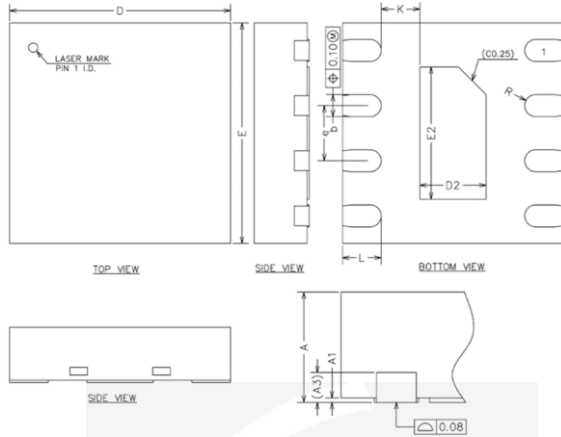

COMMON DIMENSIONS  
(UNITS OF MEASURE=MILLIMETER)

SYMBOL	MIN	NOM	MAX
A	0.70	0.75	0.80
A1	0	0.02	0.05
A3	0.20REF		
b	0.15	0.20	0.25
D	1.90	2.00	2.10
E	1.90	2.00	2.10
D2	0.50	0.60	0.70
E2	1.10	1.20	1.30
e	0.40	0.50	0.60
K	0.20	-	-
L	0.30	0.35	0.40
R	0.09	-	-

From assembly house 2:

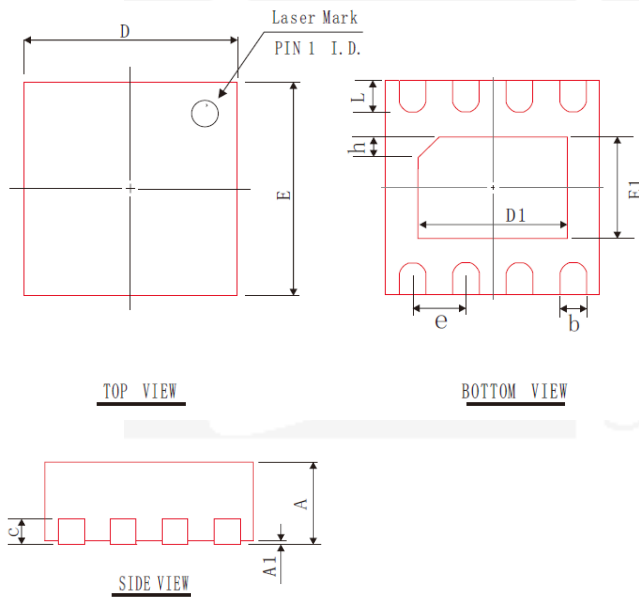

COMMON DIMENSIONS  
(UNITS OF MEASURE=mm)

SYMBOL	MIN	NOM	MAX
A	0.70	0.75	0.80
A1	0.00	0.02	0.05
b	0.20	0.25	0.30
D	1.95	2.00	2.07
E	1.95	2.00	2.07
D1	1.30	1.40	1.50
E1	0.85	0.95	1.05
L	0.25	0.30	0.35
h	0.15	0.20	0.25
c	0.203 REF		
e	0.50 BSC		

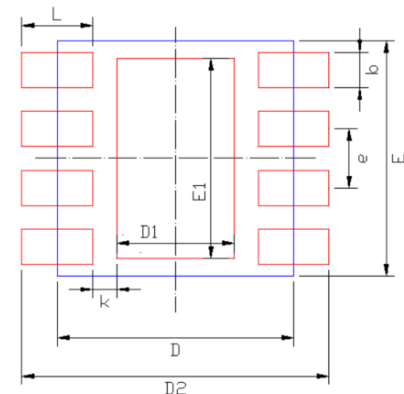

RECOMMENDED LAND PATTERN

Dimensions	Value (in mm)
D	2
E	2
D1	1
E1	1.7
D2	2.6
e	0.5
b	0.3
k	0.2 ( $\geq 0.2$ )
L	0.6

PACKAGE OUTLINE (cont')

Package: SOT23-6

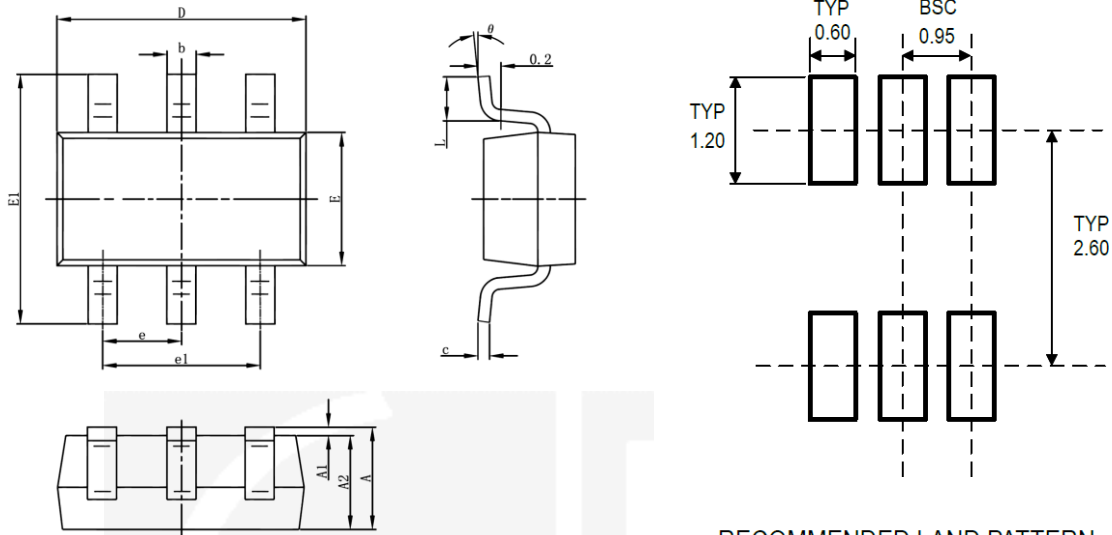

RECOMMENDED LAND PATTERN

Symbol	Dimensions In Millimeters		Dimensions In Inches	
	Min	Max	Min	Max
A	1.050	1.250	0.041	0.049
A1	0.000	0.100	0.000	0.004
A2	1.050	1.150	0.041	0.045
b	0.300	0.500	0.012	0.020
c	0.100	0.200	0.004	0.008
D	2.820	3.020	0.111	0.119
E	1.500	1.700	0.059	0.067
E1	2.650	2.950	0.104	0.116
e	0.950(BSC)		0.037(BSC)	
e1	1.800	2.000	0.071	0.079
L	0.300	0.600	0.012	0.024
$\theta$	0°	8°	0°	8°

## TAPE AND REEL INFORMATION

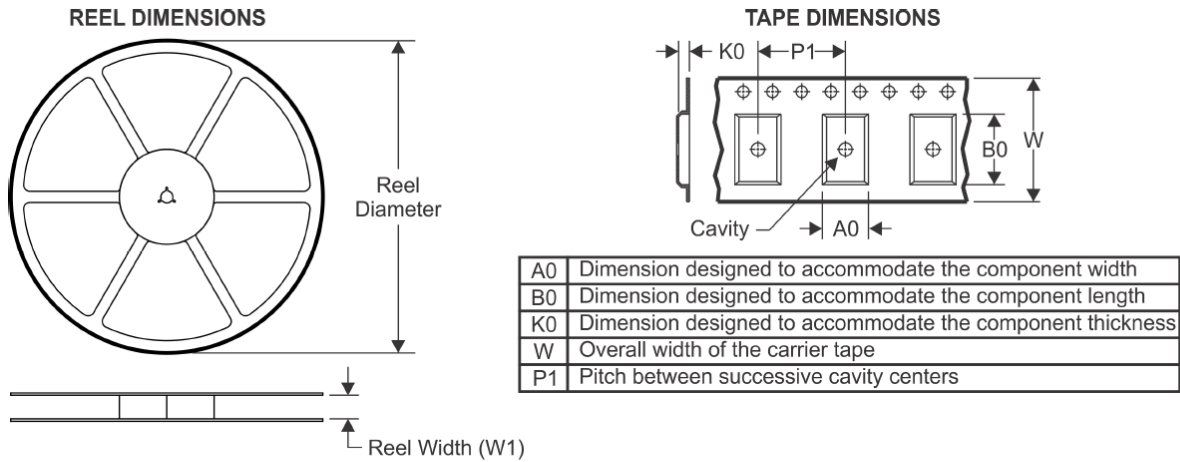

### QUADRANT ASSIGNMENTS FOR PIN 1 ORIENTATION IN TAPE

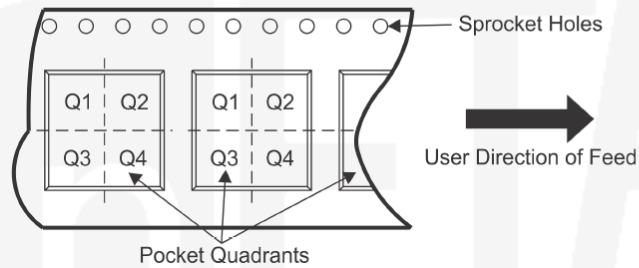

Device	Package Type	Pins	SPQ	Reel Diameter (mm)	Reel Width W1 (mm)	A0 (mm)	B0 (mm)	K0 (mm)	P1 (mm)	W (mm)	Pin1 Quadrant
ETA4056E8A	ESOP8	8	4000	330	12.7	6.6	5.4	2.05	8	12	Q1
ETA4056D6I	DFN2x3-8	8	3000	180	9.5	3.3	2.3	1.1	4	8	Q1
ETA4056D2I	DFN2x2-8	8	3000	180	9.5	2.3	2.3	1.1	4	8	Q1
ETA4056S2G	SOT23-6	6	3000	180	9.5	3.17	3.23	1.37	4	8	Q3

## X-ON Electronics

Largest Supplier of Electrical and Electronic Components

*Click to view similar products for [Battery Management](#) category:*

*Click to view products by [etasolution](#) manufacturer:*

Other Similar products are found below :

[NCP1851BFCCT1G](#) [NCP1855FCCT1G](#) [FAN54063UCX](#) [MP2615GQ-P](#) [LC05132C01NMTTGTG](#) [ISL95522HRZ](#) [BD8665GW-E2](#)  
[ISL9538HRTZ](#) [ISL95522AIRZ](#) [S-82D1AAE-A8T2U7](#) [S-82D1AAA-A8T2U7](#) [S-8224ABA-I8T1U](#) [MP2615CGQ-P](#) [ISL6251HRZ](#)  
[ISL6253HRZ](#) [ISL6292-2CR3](#) [ISL6292BCRZ-T](#) [ISL6299AIRZ](#) [ISL9211AIRU58XZ-T](#) [ISL9214IRZ](#) [ISL9220IRTZ-T](#) [FAN54161UCX](#)  
[SY6982CQDC](#) [IP6566\\_AC\\_30W\\_ZM](#) [WS3221C-6/TR](#) [ADBMS1818ASWAZ-RL](#) [ADBMS6815WCSWZ](#) [ML5245-005AMBZ07CX](#)  
[BQ25672RQMR](#) [ADBMS1818ASWZ-R7](#) [KA49503A-BB](#) [SC33771CTA1MAE](#) [BQ24060DRCR](#) [BQ7695202PFBR](#) [BQ771809DPJR](#)  
[BQ24179YBGR](#) [BQ7693002DBTR](#) [BQ25170DSGR](#) [TP4586](#) [FM2119L](#) [FM1623A](#) [DW01](#) [BQ25172DSGR](#) [DW01S](#) [TP4054](#) [MP2723GQC-](#)  
[0000-Z](#) [MP26124GR-Z](#) [MP2664GG-0000-Z](#) [MP26029GTF-0000-Z](#) [MP2695GQ-0000-Z](#)