

2.5A, 3MHz Switching Charger with Dynamic Power Path in ESOP8

DESCRIPTION

ETA6002 is a switching Li-Ion battery charger with dynamic power-path control and input current limiting.

When a battery is connected, depending on the battery voltage, the DC-DC switching regulator either pre-conditions, fast-charges the battery or just regulates a system voltage (V_{SYS}) to a preset voltage. It does not require an external sense resistor for current sensing. The fast-charging current is determined by programming ISET pin. When the battery voltage reaches the termination voltage i.e., 4.2V, the charging path disconnects SYS to BATT. The ETA6002 also includes a dynamic power path when the SYS load current exceeds current limit of the DCDC regulator internally set, the SYS voltage falls below V_{BATT} , ETA6002 turns on the power-path to supplement the system load through the battery.

FEATURES

- ◆ Switching Charger with Power Path Management
- ◆ Up to 95% DC-DC Efficiency
- ◆ 50mΩ Power Path MOSFET
- ◆ Up to 2.5A Max charging current
- ◆ Instant on with a dead Battery or no Battery
- ◆ No Battery Detection
- ◆ No External Sense Resistor
- ◆ Programmable Charging Current
- ◆ RoHS Compliant

APPLICATIONS

- ◆ Tablet, MID
- ◆ Smart Phone
- ◆ Power Bank

TYPICAL APPLICATION

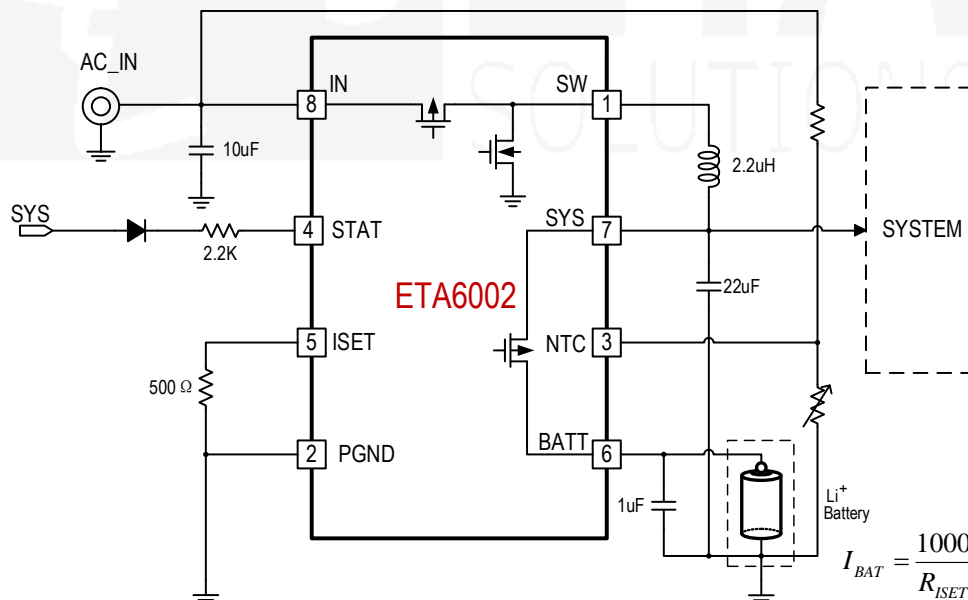

ORDERING INFORMATION

PART No.	PACKAGE	TOP MARK	Pcs/Reel
ETA6002E8A	ESOP-8	ETA6002 YWWPL	4000

PIN CONFIGURATION

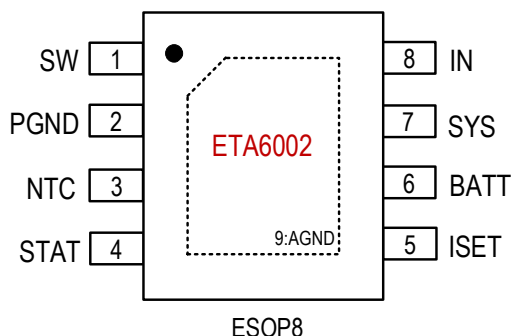

ABSOLUTE MAXIMUM RATINGS

(Note: Exceeding these limits may damage the device. Exposure to absolute maximum rating conditions for long periods may affect device reliability.)

IN, BATT Voltage	-0.3V to 6V
All Other Pin Voltage.....	V _{IN} -0.3V to V _{IN} +0.3V
SW, SYS, BATT to ground current...	Internally limited
Operating Temperature Range.....	-40°C to 85°C
Storage Temperature Range.....	-55°C to 150°C
Thermal Resistance θ _{JA}	
ESOP8.....	50 °C /W

ELECTRICAL CHARACTERISTICS

(V_{IN} = 5V, unless otherwise specified. Typical values are at TA = 25°C.)

PARAMETER	CONDITIONS	MIN	TYP	MAX	UNITS
IN INPUT					
INPUT Range		4.4		5.5	V
INPUT UVLO	Rising, Hys=500mV		4.35		V
INPUT Operating Current	Switcher Enable, Switching		5		mA
	Switcher Enable, No Switching		70		µA
BATT to INPUT Leakage Current	Input Floating		0	5	µA
DC-DC and SYS OUTPUT					
V _{SYSTEMIN}	I _{SYSTEM} =1A, Default		3.6		V
V _{SYSTEMMAX}			4.5		V
Load Regulation			40		mV/A
Line Regulation	V _{IN} = 4.75 to 5.25V		0.04		%/V
Switching Frequency			3		MHz
Max Duty		100			%
HIGHSIDE MOS RDSON	I _{SW} =500mA		100		mΩ
LOWSIDE MOS RDSON	I _{SW} =500mA		60		mΩ
HIGHSIDE Current Limit			3.5		A
SYS UVLO	Falling, Hys=200mV		2.25		V
Thermal Shutdown	Rising, Hys=30°C		160		°C
POWER PATH Management					
BATT TO SYS RDSON			50		mΩ
BATTERY CHARGER					
Battery CV Voltage	I _{BAT} =0mA, Default	4.16	4.2	4.24	V
Charger Restart Threshold	From DONE to Fast Charge		-200		mV
Battery Pre-condition Voltage	V _{BAT} Rising Hys=180mV		2.9		V
Pre-condition Charge Current			100		mA

PARAMETER	CONDITIONS	MIN	TYP	MAX	UNITS
AC Fast Charge Current	$R_{ISET1} = 500\Omega$, $nUSB_DET = V_{IN}$		2		A
	$R_{ISET1} = 2000\Omega$	0.45	0.5	0.55	A
Pre-Condition Timer			120		min
Fast-Charge Timer			960		min
THERMISTOR MONITOR					
NTC Threshold, Cold	Charger Suspended		76.5		$\%V_{IN}$
NTC Threshold, Hot	Charger Suspended		35		$\%V_{IN}$
NTC Threshold Hysteresis			1.5		$\%V_{IN}$
NTC Disable Threshold			100		mV
NTC Input Leakage			0		μA
STATS					
STAT Output Low Voltage	$I_{STATS} = 10mA$			0.2	V

PIN DESCRIPTION

PIN #	NAME	DESCRIPTION
1	SW	Switching node of the Switching Regulator. Connect a $1\mu H$ to $2.2\mu H$ inductor from this pin to SYS
2	PGND	Power Ground pin. Bypass with a $10\mu F$ capacitor to IN
3	NTC	Thermistor Input
4	STAT	Status pin for Charging status indications. An open drain device capable of driving 10mA current
5	ISET	Fast Charge Current set pin. Connecting a Resistor between ISET to GND This sets the fast charge current value $I_{BAT} = \frac{1000}{R_{ISET}}$
6	BATT	Battery pin. Connect a Battery to this pin
7	SYS	System Voltage pin. It is also the Switching regulator's output pin. Connect an inductor and capacitor to form the output filter
8	IN	Input pin. Can be connected to an AC adaptor or a USB charger output. Bypass with a $10\mu F$ capacitor each to PGND
9 (EP)	AGND	Exposed pad for analog ground connection. Must be connected to PGND on PCB

TYPICAL CHARACTERISTICS

(Typical values are at $T_A = 25^\circ\text{C}$ unless otherwise specified.)

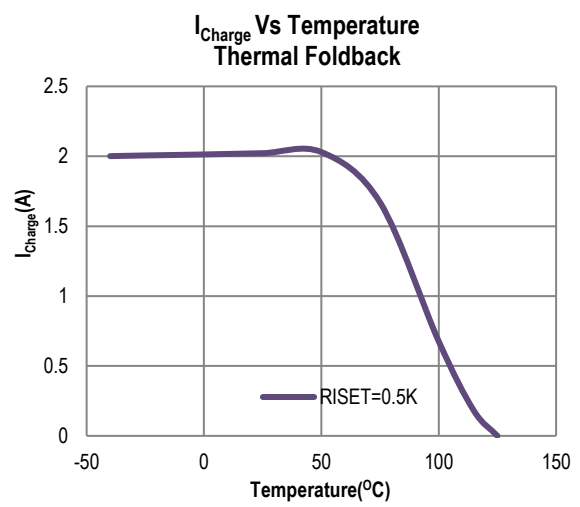
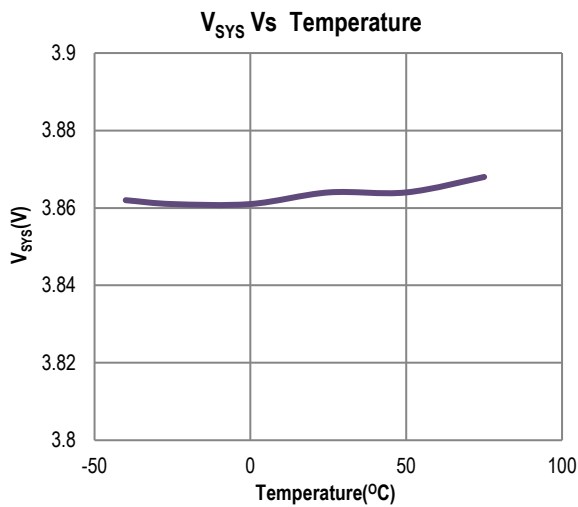
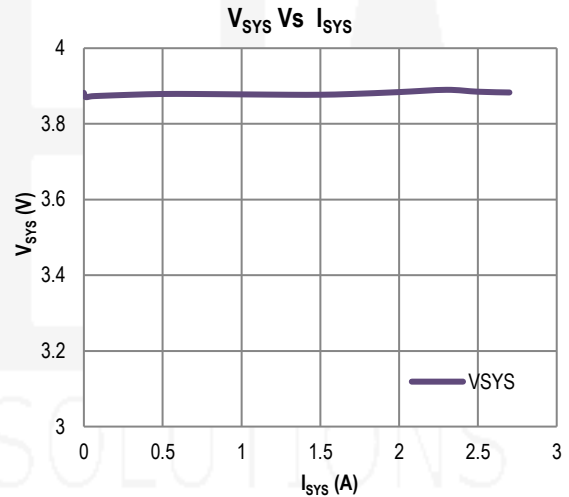
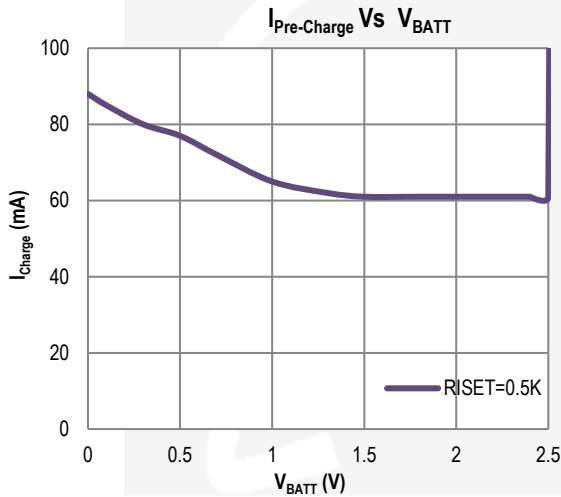
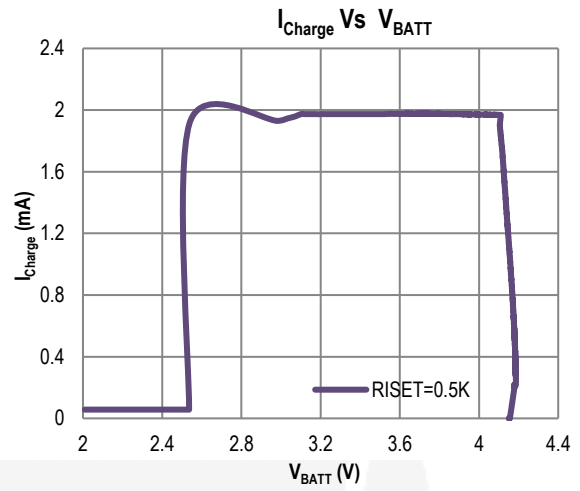
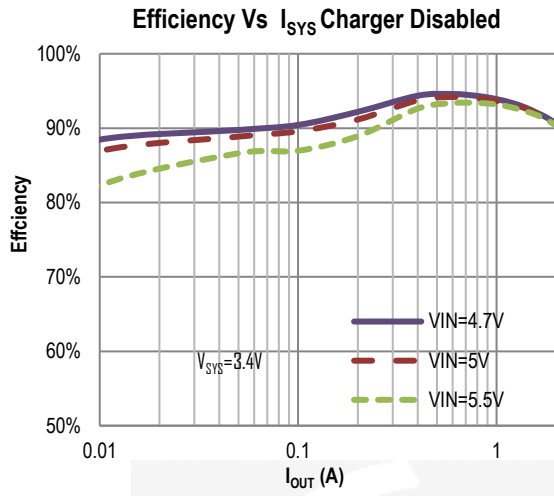

TYPICAL APPLICATION CIRCUIT

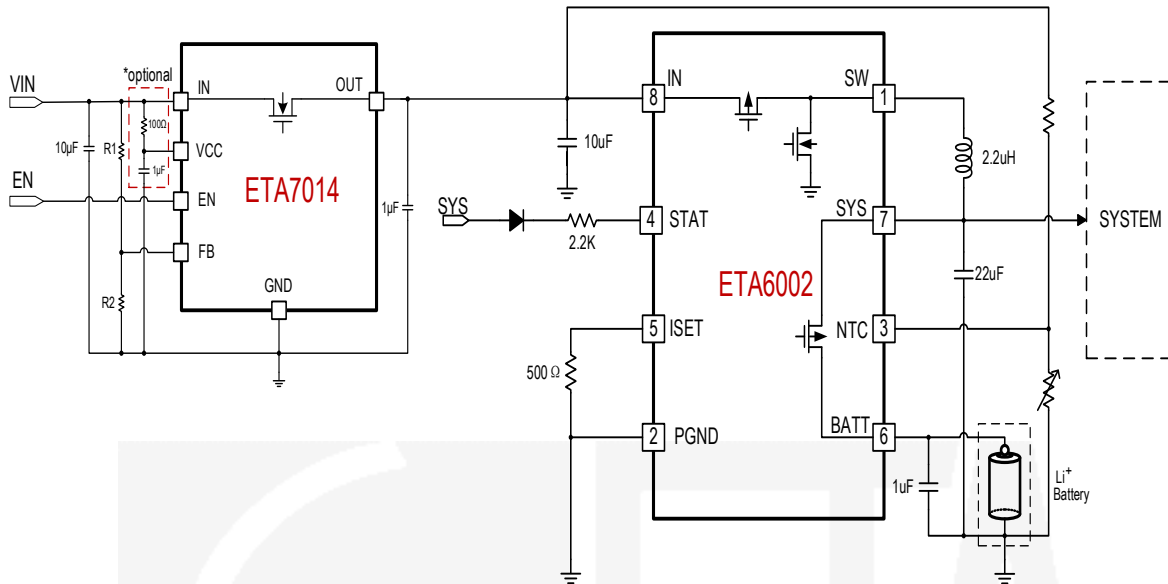

2A Switching Charger with Dynamic Power Path with OVP protection and Charge Enable

FUNCTIONAL DESCRIPTION

Status Indicators

STAT pin is a status pin for charging status indications. Please refer to Table 1.

Table 1 STAT indicator

CHARGE STATE	STAT OUTPUT
Charging	Low
Charging done	High impedance
Safety timers expired	Flashing at 1 Hz
NTC protect	
No battery	

Battery Charge Profile

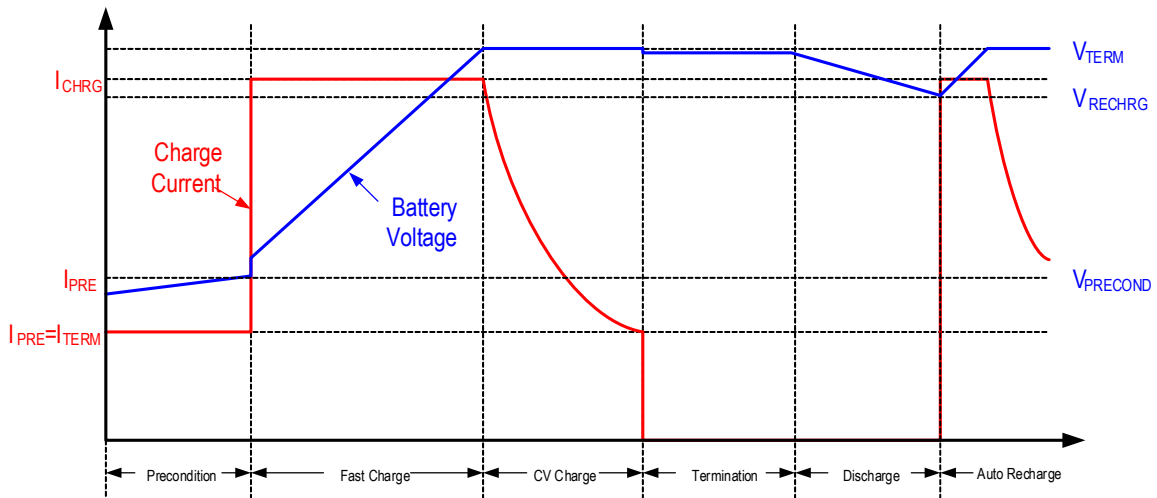

Charge Current Translator

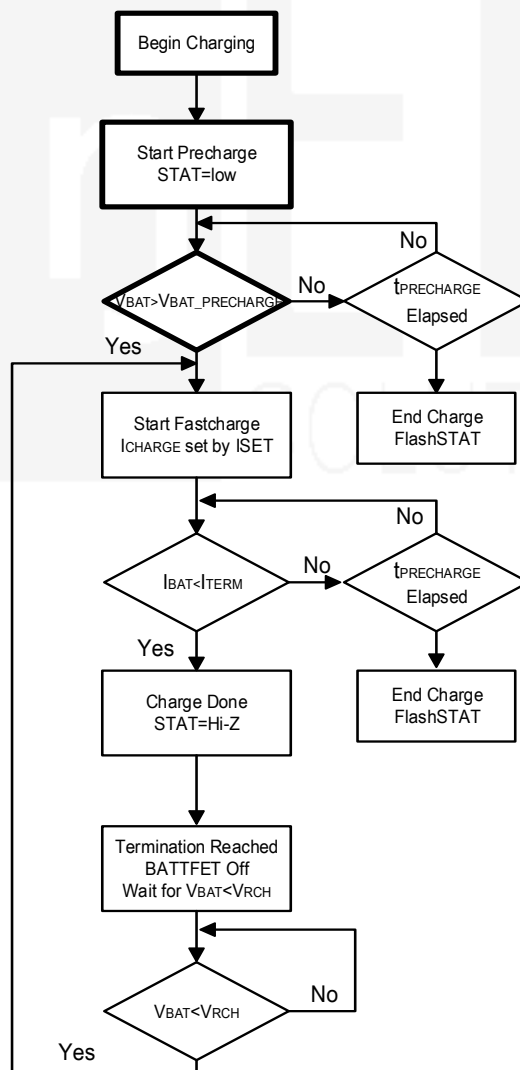

FUNCTION BLOCK DIAGRAM

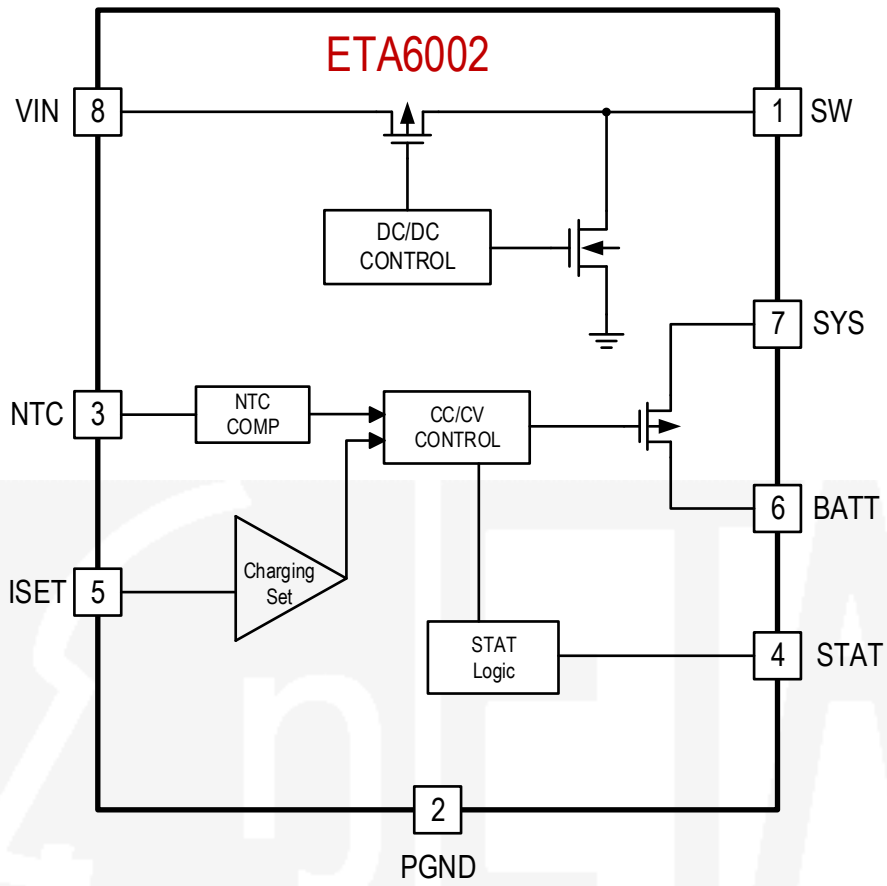

PACKAGE OUTLINE

Package: ESOP8

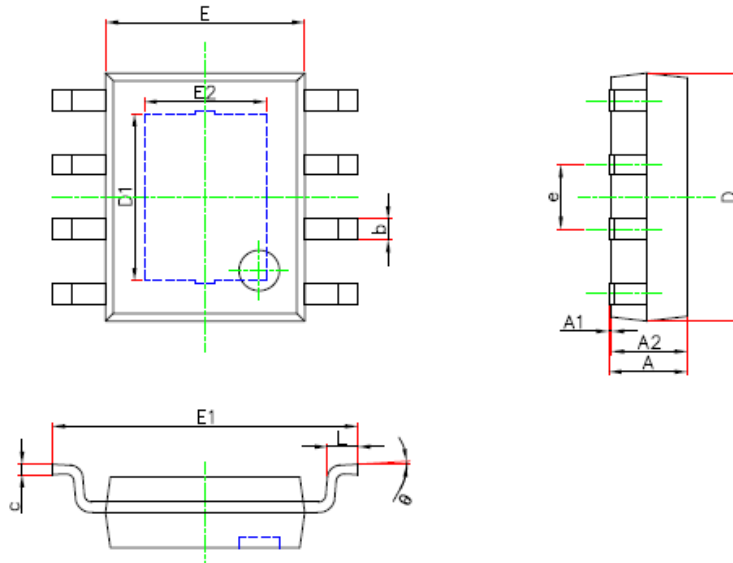

Symbol	Dimensions In Millimeters		Dimensions In Inches	
	Min.	Max.	Min.	Max.
A	1.300	1.700	0.051	0.067
A1	0.000	0.100	0.000	0.004
A2	1.350	1.550	0.053	0.061
b	0.330	0.510	0.013	0.020
c	0.170	0.250	0.007	0.010
D	4.700	5.100	0.185	0.201
D1	3.202	3.402	0.126	0.134
E	3.800	4.000	0.150	0.157
E1	5.800	6.200	0.228	0.244
E2	2.313	2.513	0.091	0.099
e	1.270(BSC)		0.050(BSC)	
L	0.400	1.270	0.016	0.050
θ	0°	8°	0°	8°

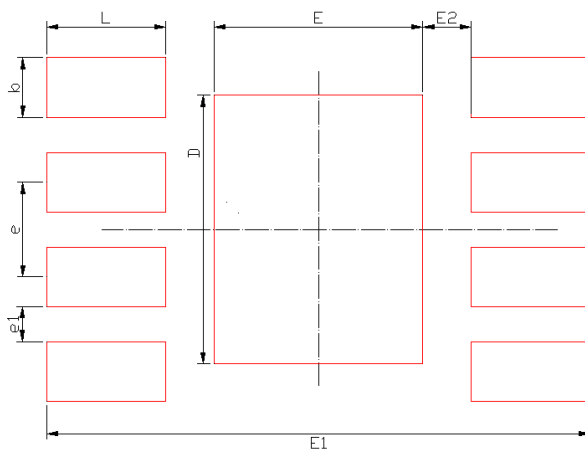

Dimensions	Value (in mm)
D	3.6
E	2.8
E1	7.3
E2	0.65
b	0.8
e	1.27
e1	0.47
L	1.6

RECOMMENDED LAND PATTERN

TAPE AND REEL INFORMATION

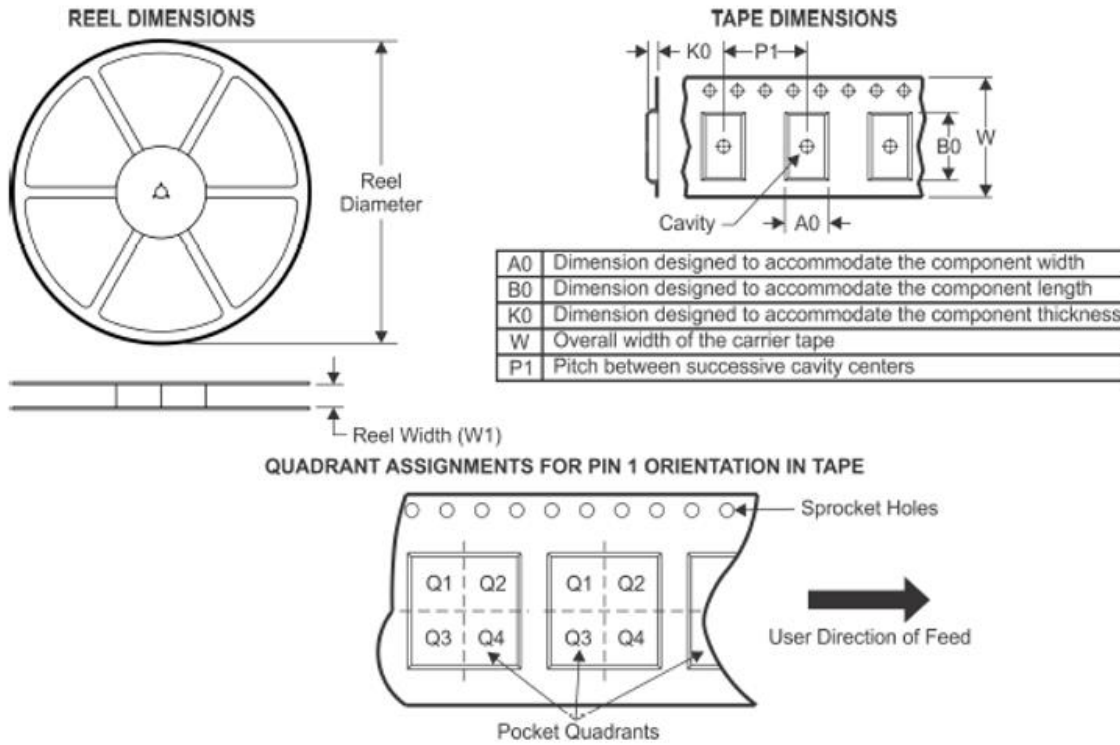

Device	Package Type	Pins	SPQ	Reel Diameter (mm)	Reel Width W1 (mm)	A0 (mm)	B0 (mm)	K0 (mm)	P1 (mm)	W (mm)	Pin1 Quadrant
ETA6002E8A	ESOP8	8	4000	330	12.7	6.6	5.4	2.05	8	12	Q1

X-ON Electronics

Largest Supplier of Electrical and Electronic Components

Click to view similar products for [Battery Management](#) category:

Click to view products by [etasolution](#) manufacturer:

Other Similar products are found below :

[NCP1851BFCCT1G](#) [NCP1855FCCT1G](#) [FAN54063UCX](#) [MP2615GQ-P](#) [LC05132C01NMTTGTG](#) [ISL95522HRZ](#) [BD8665GW-E2](#)
[ISL9538HRTZ](#) [ISL95522AIRZ](#) [S-82D1AAE-A8T2U7](#) [S-82D1AAA-A8T2U7](#) [S-8224ABA-I8T1U](#) [MP2615CGQ-P](#) [ISL6251HRZ](#)
[ISL6253HRZ](#) [ISL6292-2CR3](#) [ISL6292BCRZ-T](#) [ISL6299AIRZ](#) [ISL9211AIRU58XZ-T](#) [ISL9214IRZ](#) [ISL9220IRTZ-T](#) [FAN54161UCX](#)
[SY6982CQDC](#) [IP6566_AC_30W_ZM](#) [WS3221C-6/TR](#) [ADBMS1818ASWAZ-RL](#) [ADBMS6815WCSWZ](#) [ML5245-005AMBZ07CX](#)
[BQ25672RQMR](#) [ADBMS1818ASWZ-R7](#) [KA49503A-BB](#) [SC33771CTA1MAE](#) [BQ24060DRCR](#) [BQ7695202PFBR](#) [BQ771809DPJR](#)
[BQ24179YBGR](#) [BQ7693002DBTR](#) [BQ25170DSGR](#) [TP4586](#) [FM2119L](#) [FM1623A](#) [DW01](#) [BQ25172DSGR](#) [DW01S](#) [TP4054](#) [MP2723GQC-](#)
[0000-Z](#) [MP26124GR-Z](#) [MP2664GG-0000-Z](#) [MP26029GTF-0000-Z](#) [MP2695GQ-0000-Z](#)