

## Ultra-Small, Low ON Resistance Load Switch with Auto-Discharge Path

### DESCRIPTION

The ETA7017/A is a small, low R<sub>DS(on)</sub> switch with controlled turn on. The device contains a PMOS that can operate over an input voltage range of 1.4V to 5.5V. The switch is controlled by an external logic pin, which is an active high enable.

The ETA7017/A contains a 65mohm on-chip resistor for quick discharge when the switch is turned off. Quiescent current and shutdown current are all less than 1uA at V<sub>IN</sub>=5.5V.

The ETA7017/A is available in a very small WLCSP 0.87x0.87-4 package.

### FEATURES

- ◆ Less than 1uA Quiescent and Shutdown Current
- ◆ 1.4V-5.5V Operating Range
- ◆ Low On-Resistance, R<sub>DS(on)</sub>=65mohm@V<sub>IN</sub>=3.3V
- ◆ Up to 2A Continuous Output Current
- ◆ Output Auto Discharge
- ◆ Active high EN pin
- ◆ ESD Ratings: 4KV Human body mode

### APPLICATIONS

- ◆ NB-IOT module
- ◆ Wireless communication module

### TYPICAL APPLICATION

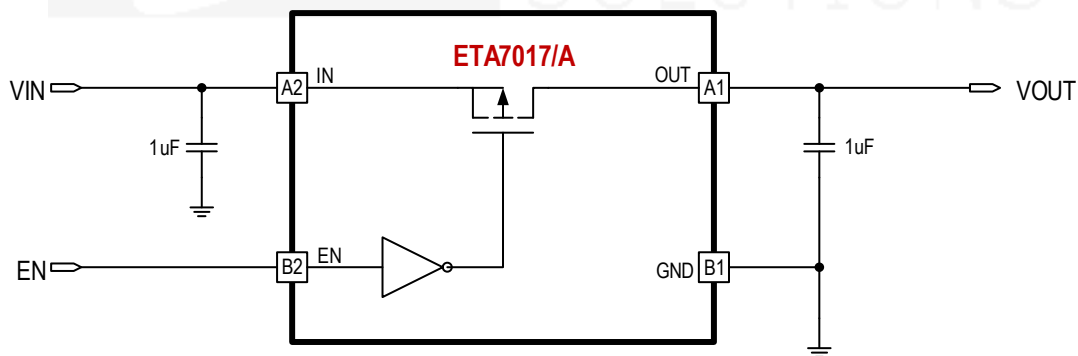

Typical Application Circuit

### ORDERING

### INFORMATION

PART No.	PACKAGE	TOP MARK	Pcs/Reel
ETA7017CSE	WLCSP 0.87x0.87-4	HFYW	3000
ETA7017ACSE	WLCSP 0.87x0.87-4	HPYW	3000

## PIN CONFIGURATION

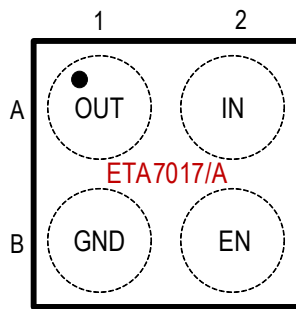

WLCSP0.87x0.87-4

## ABSOLUTE MAXIMUM RATINGS

(Note: Exceeding these limits may damage the device. Exposure to absolute maximum rating conditions for long periods may affect device reliability.)

IN, OUT, EN Voltage .....	-0.3V to 7V
Operating Temperature Range.....	-40°C to 85°C
Storage Temperature Range.....	55°C to 150°C
Thermal Resistance $\theta_{JA}$	
WLCSP 0.87x0.87 .....	100 °C/W
Lead Temperature (Soldering, 10sec) .....	260°C
ESD HBM (Human Body Mode) .....	4KV
ESD CDM (Charged Device Mode) .....	1KV
ESD MM (Machine Mode) .....	300V

## ELECTRICAL CHARACTERISTICS

(VIN = 1.4V-5.5V, unless otherwise specified. Typical values are at TA = 25°C.)

PARAMETER	CONDITIONS	MIN	TYP	MAX	UNITS
Switch RDSON	VIN=5.5V, IOU=0.2A		56		mohm
	VIN=5.0V, IOU=0.2A		58		
	VIN=4.2V, IOU=0.2A		60		
	VIN=3.3V, IOU=0.2A		65		
	VIN=2.5V, IOU=0.2A		73		
	VIN=1.8V, IOU=0.2A		93		
	VIN=1.4V, IOU=0.2A		128		
OUT Discharge Resistance	VIN=5.5V, VEN=0, VOUT=1V		42	65	ohm
	VIN=3.3V, VEN=0, VOUT=1V		53		
	VIN=1.8V, VEN=0, VOUT=1V		130		
IN Quiescent Current	VIN=5V, VEN=VIN		200	400	nA
	VIN =3.3V, VEN=VIN		100	200	
IN Shutdown Current	VIN=5V, VEN=0		50	100	nA
	VIN=3.3V, VEN=0		50	100	
EN Input High Level	VIN=5.5V	1.1			V
	VIN=3.6V	1.1			
	VIN=1.4V	1.1			
EN Input Low Level	VIN=5.5V			0.6	V
	VIN=3.6V			0.6	
	VIN=1.4V			0.4	
EN Pull Down Resistance			10		Mohm

OUT Rising Time	VIN=5.5V, COUT=1uF, ROUT=22Ω @ETA7017	314	μS
	VIN=5.5V, COUT=1uF, ROUT=22Ω @ETA7017A	44	
	VIN=3.6V, COUT=1uF, ROUT=22Ω @ETA7017	238	
	VIN=3.6V, COUT=1uF, ROUT=22Ω @ETA7017A	40	
	VIN=1.4V, COUT=1uF, ROUT=22Ω @ETA7017	85	
	VIN=1.4V, COUT=1uF, ROUT=22Ω @ETA7017A	25	
OUT Falling Time	VIN=5.5V, COUT=1uF, ROUT=22Ω	35	μS
	VIN=3.6V, COUT=1uF, ROUT=22Ω	44	
	VIN=1.4V, COUT=1uF, ROUT=22Ω	50	
Turn On Time	VIN=5.5V, COUT=1uF, ROUT=22Ω @ETA7017	450	μS
	VIN=5.5V, COUT=1uF, ROUT=22Ω @ETA7017A	56	
	VIN=3.6V, COUT=1uF, ROUT=22Ω @ETA7017	410	
	VIN=3.6V, COUT=1uF, ROUT=22Ω @ETA7017A	66	
	VIN=1.4V, COUT=1uF, ROUT=22Ω @ETA7017	320	
	VIN=1.4V, COUT=1uF, ROUT=22Ω @ETA7017A	78	
Turn Off Time	VIN=5.5V, COUT=1uF, ROUT=22Ω	10	μS
	VIN=3.6V, COUT=1uF, ROUT=22Ω	12	
	VIN=1.4V, COUT=1uF, ROUT=22Ω	18	
OUT Short Hiccup On Time	VIN=3.3V@ETA7017	4	mS
	VIN=3.3V@ETA7017A	0.35	
OUT Short Hiccup Off Time	VIN=3.3V@ETA7017	4	mS
	VIN=3.3V@ETA7017A	2	
OUT Short Current at Hiccup On Time	VIN=3.3V@ETA7017	1.5	A
	VIN=3.3V@ETA7017A	2	
Maximum Load Current	VIN=5.5V	3.5	A
	VIN=3.6V	3.5	
	VIN=1.4V	2	

## PIN DESCRIPTION

PIN #	NAME	DESCRIPTION
A1	OUT	Switch output, connect 1uF ceramic capacitor from OUT to GND as close as possible to the IC.
B1	GND	IC Ground
A2	IN	Switch input, connect 1uF ceramic capacitor from IN to GND as close as possible to the IC.
B2	EN	Enable input, Logic high turns on the power switch.

## TYPICAL CHARACTERISTICS

(Typical values are at  $T_A = 25^\circ\text{C}$  unless otherwise specified.)

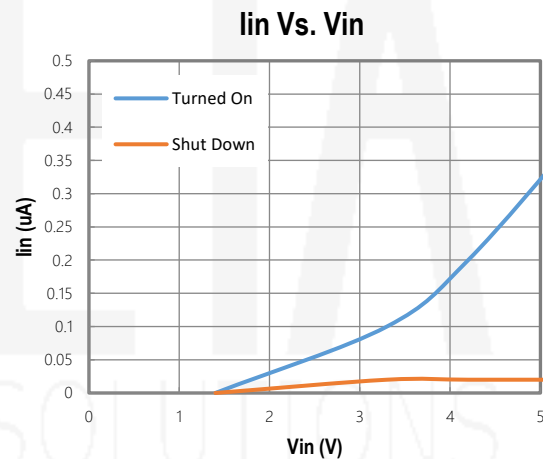
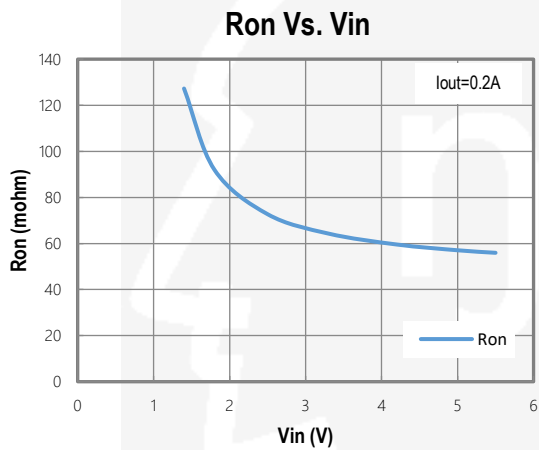

## PCB GUIDELINES

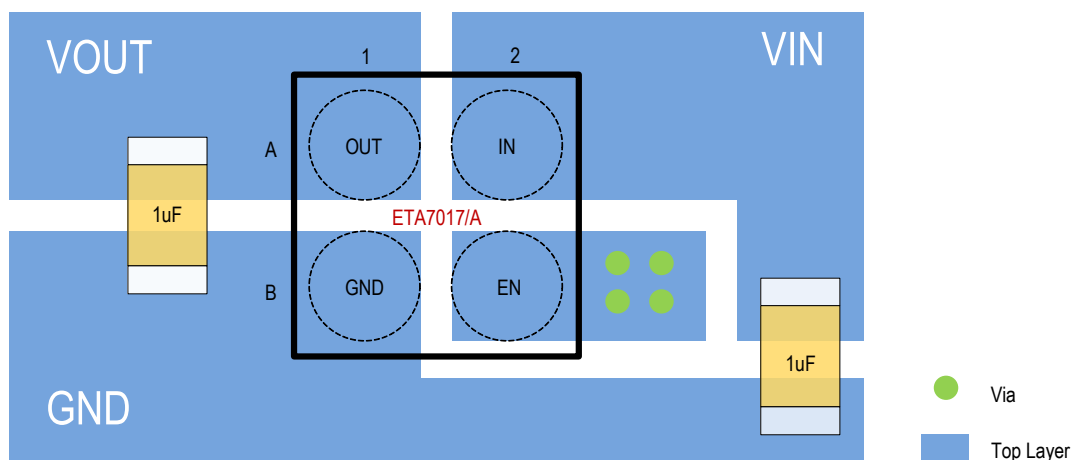

BLOCK DIAGRAM

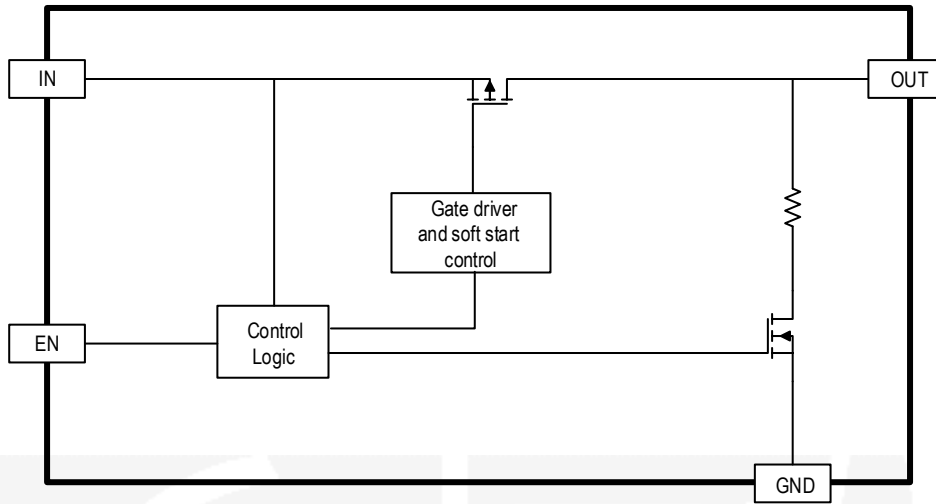

PACKAGE OUTLINE

WLCSP 0.87x0.87-4

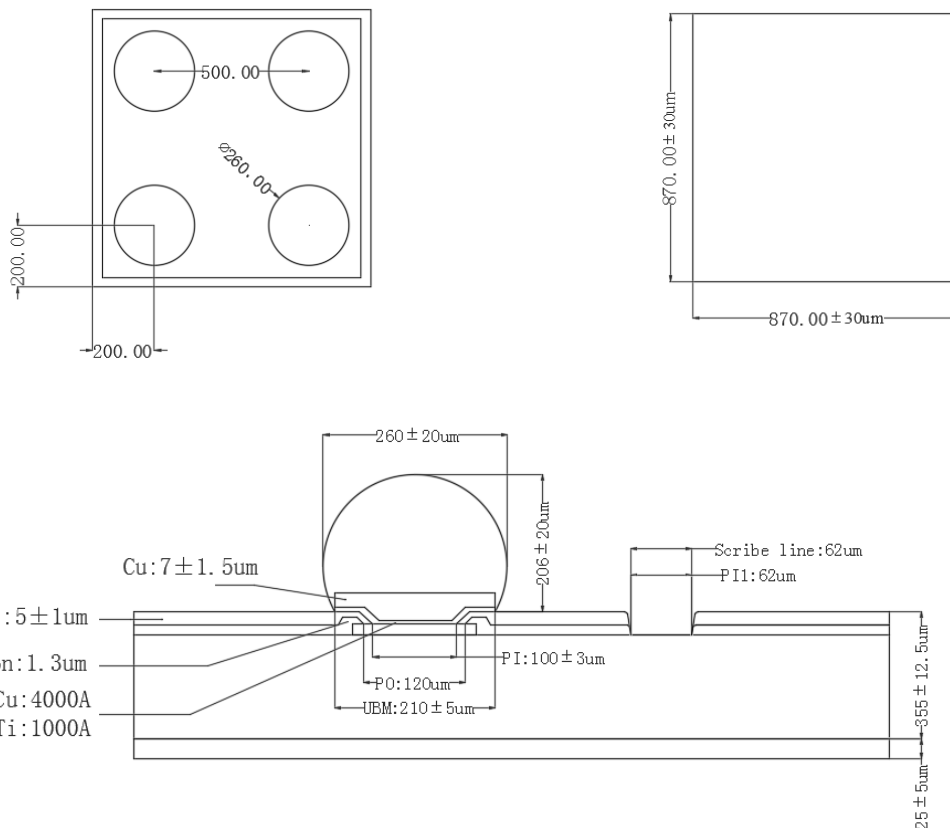

## TAPE AND REEL INFORMATION

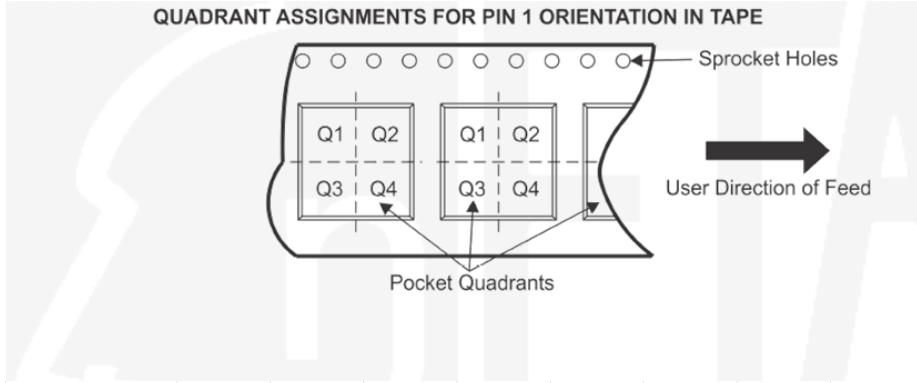
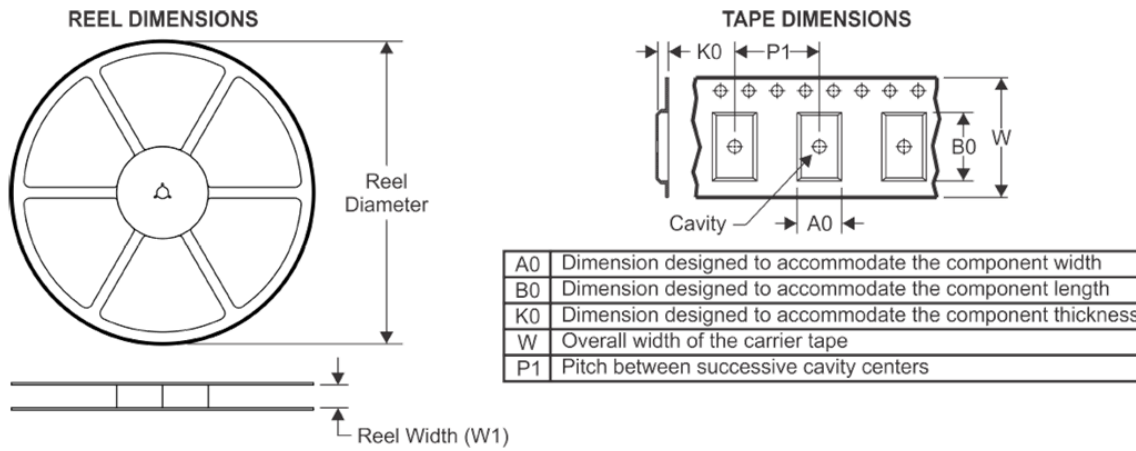

Device	Package Type	Pins	SPQ	Reel Diameter (mm)	Reel Width W1 (mm)	A0 (mm)	B0 (mm)	K0 (mm)	P1 (mm)	W (mm)	Pin1 Quadrant
ETA7017CSE	WLCSP0.87x0.87-4	4	3000	178	9.5	0.96	0.96	0.68	2	8	Q1
ETA7017ACSE	WLCSP0.87x0.87-4	4	3000	178	9.5	0.96	0.96	0.68	2	8	Q1

## X-ON Electronics

Largest Supplier of Electrical and Electronic Components

*Click to view similar products for [Power Switch ICs - Power Distribution](#) category:*

*Click to view products by [etasolution](#) manufacturer:*

Other Similar products are found below :

[TLE6232GP](#) [NCP45520IMNTWG-L](#) [VND5E004ATR-E](#) [FPF1018](#) [DS1222](#) [NCV380HMUAJAATBG](#) [SZNCP3712ASNT3G](#)  
[NCP45520IMNTWG-H](#) [VND5004ATR-E](#) [AP22811BW5-7](#) [SLG5NT1437VTR](#) [SZNCP3712ASNT1G](#) [DML1008LDS-7](#) [TS13011-QFNR](#)  
[VND7012AYTR](#) [NCV459MNWTBG](#) [NCP4545IMNTWG-L](#) [NCV8412ASTT1G](#) [NCV8412ASTT3G](#) [FPF2260ATMX](#) [SLG5NT1765V](#)  
[SLG5NT1757V](#) [NCP45780IMN24RTWG](#) [AP2151DMPG-13](#) [AP2151AMP-13](#) [NCP45540IMNTWG-L](#) [TPS2022P](#) [FPF2495BUCX](#)  
[NCP45650IMNTWG](#) [NCV8412ADDR2G](#) [DK5V100R20S](#) [BTS7020-2EPA](#) [BTT6100-2ERA](#) [BTS71220-4ESA](#) [DK5V100R15M](#)  
[WS3220C9-9/TR](#) [BTT6030-2ERA](#) [TLE75602-ESH](#) [BTS5200-4EKA](#) [DK5V150R25M](#) [DK5V45R25](#) [DK5V100R25S](#) [AW35206FOR](#)  
[BTS7120-2EPA](#) [TLE75008-ESD](#) [BTS7040-1EPA](#) [BTT6030-1ERA](#) [DK5V60R10S](#) [DK5V45R25S](#) [DK5V60R10](#)