

17V/6A High Efficiency Synchronous Step-Down Converter

DESCRIPTION

ETA8156 is a wide input range, high efficiency and high frequency DC to DC step-down switching regulator, capable of delivering up to 6A output current. It adopts an adaptive COT control scheme that enables very fast transient response and provides a very smooth transition when the output varies from light load to heavy load. During light load, ETA8156 goes into a PFM mode that saves switching loss achieving high efficiency. An OVP function protects the IC itself and its downstream system against input voltage surges.

ETA8156 is available in FCTSOT23-6 Package.

FEATURES

- ◆ Wide Input Range: 4.5V-17V
- ◆ Adaptive COT Control
- ◆ Ultra-fast Load Transient Response
- ◆ High Efficiency PFM Mode at Light Load
- ◆ Low RDS(ON) Internal Power FETs
- ◆ Capable of Delivering Up to 6A
- ◆ No External Compensation Needed
- ◆ Thermal Shutdown and UVLO
- ◆ Output Auto-discharge Function
- ◆ Available in FCTSOT23-6 Package
- ◆ RoHS compliant

APPLICATIONS

- ◆ LCD TV
- ◆ Set Top Box
- ◆ DSL Modem

TYPICAL APPLICATION

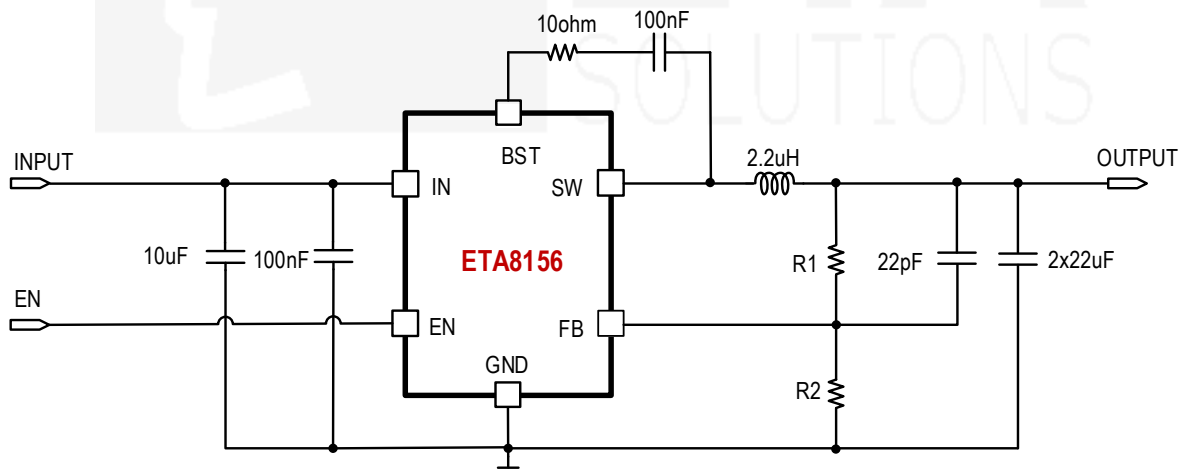

Figure 1: Typical Application Circuit

*R2 has to be set between 1KΩ to 24KΩ

ORDERING INFORMATION

PART No.	PACKAGE	TOP MARK	Pcs/Reel
ETA8156FT2G	FCTSOT23-6	MIYW	3000

PIN CONFIGURATION

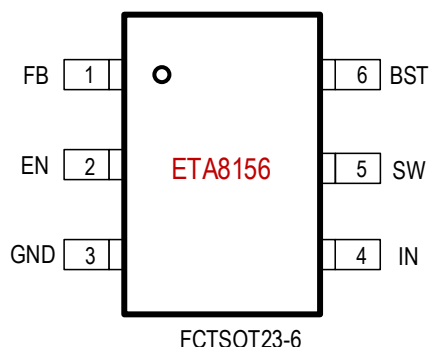

ABSOLUTE MAXIMUM RATINGS

(Note: Exceeding these limits may damage the device. Exposure to absolute maximum rating conditions for long periods may affect device reliability)

IN, EN Voltage	-0.3V to 19V
SW Voltage	-0.3V (-5V for <10nS) to 19V (23V for <10nS)
BST Voltage.....	-0.3V to SW+6V
FB Voltage	-0.3V to 6V
Operating Temperature Range.....	-40°C to 85°C
Storage Temperature Range	-55°C to 150°C
Thermal Resistance	θ_{JA} θ_{JC}
FCTSOT23-6.....	56.....6.3... °C/W
Lead Temperature (Soldering 10 sec).....	260°C

ELECTRICAL CHARACTERISTICS

($V_{IN}=12V$, $V_{OUT}=3.3V$, unless otherwise specified. Typical values are at $T_A = 25^\circ C$.)

PARAMETER	TEST CONDITIONS	MIN	TYP	MAX	UNIT
Input Supply Range		4.5		17	V
Input Under Voltage Lockout	V_{IN} Rising		4.05		V
UVLO Hysteresis	V_{IN} Falling		300		mV
IN Over Voltage Protection Threshold	V_{IN} Rising		18.5		V
OVP Hysteresis	V_{IN} Falling		0.9		V
Quiescent Current	$V_{EN} = 2V$		230		μA
Shutdown Current	$V_{EN} = 0V$		7	17	μA
Output Discharge Resistance	$V_{EN} = 0V$		50		Ω
FB Pin Regulation Voltage		0.594	0.6	0.606	V
FB Input Current			0	1	μA
Switching Frequency			550		KHz
Maximum Duty Cycle			97		%
Short Circuit Hiccup Time	On Time		2		ms
	Off Time		6		ms
FB out of Hiccup Threshold	V_{OUT} rising		75		%
FB under voltage hysteresis	V_{OUT} falling		50		mV
High Side Switch On Resistance	$I_{SW}=1A$		20		m Ω
Low Side Switch On Resistance	$I_{SW}=1A$		15		m Ω
SW Leakage Current	$V_{IN}=V_{SW}=12V$			10	μA
Peak Inductor Protection Current	High Side ON		14.5		A
Low Side Current Limit Protection			7.9		A
EN Rising Threshold			1.15		V
EN Threshold Hysteresis			100		mV

PARAMETER	TESTCONDITIONS	MIN	TYP	MAX	UNIT
EN Input Current			2	6	μA
Thermal Shutdown			155		°C
Thermal Hysteresis			40		°C

PIN DESCRIPTION

PIN #	PIN NAME	DESCRIPTION
1	FB	Feedback Input. Connect an external resistor divider from the output to FB and GND to set V_{OUT} .
2	EN	Enable pin for the IC. Drive this pin high to enable the part, low or floating to disable.
3	GND	Ground
4	IN	Supply Voltage. Bypass with a 100nF HF filter plus a 10μF ceramic capacitor to GND
5	SW	Inductor Connection. Connect an inductor between SW and the regulator output.
6	BST	Bootstrap pin. Connect a 100nF capacitor from this pin to SW

FUNCTIONAL BLOCK DIAGRAM

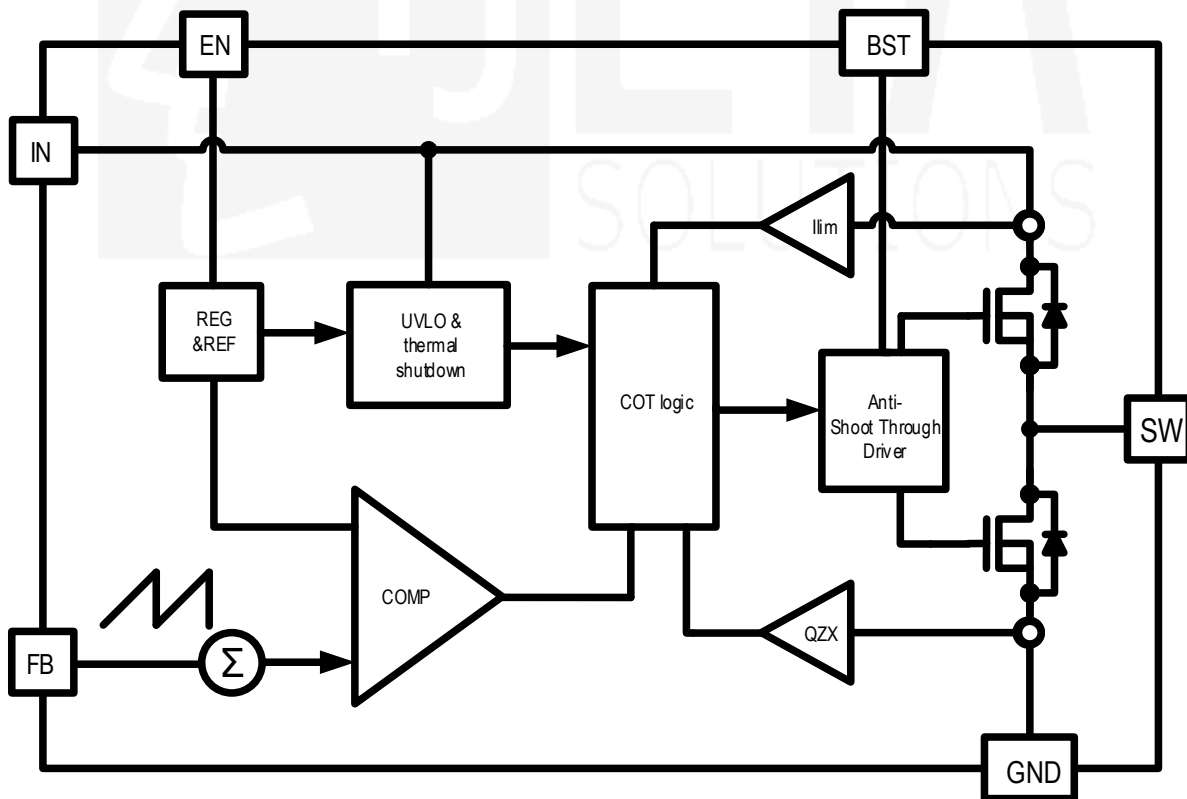
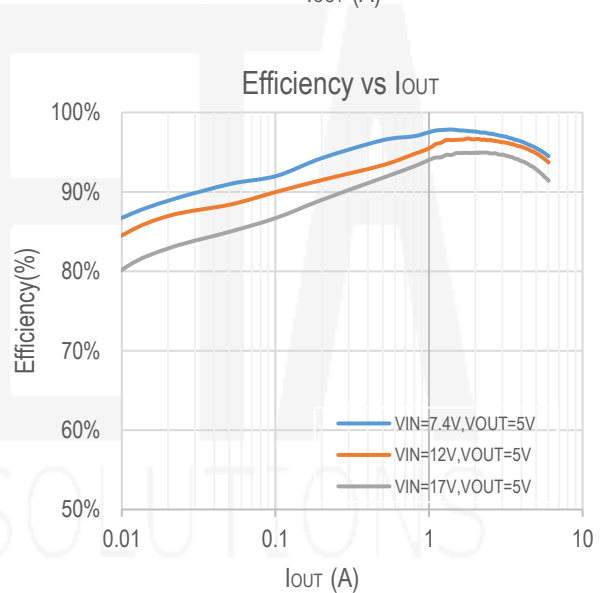
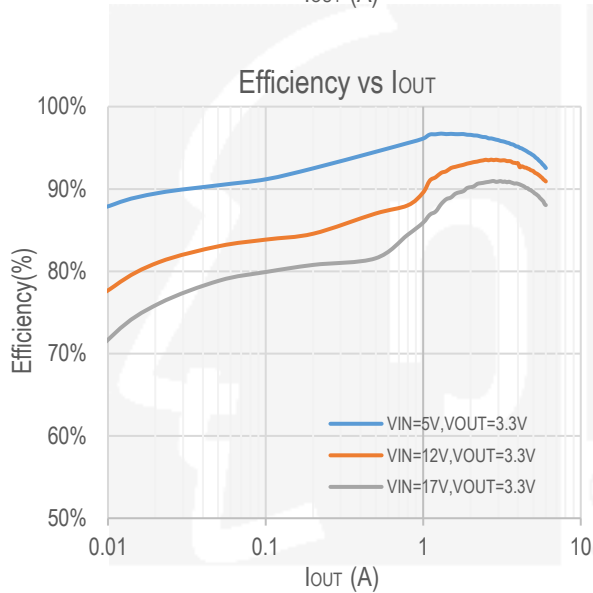
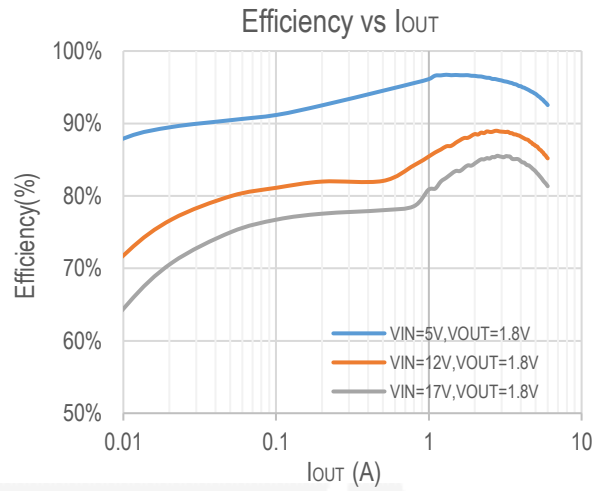
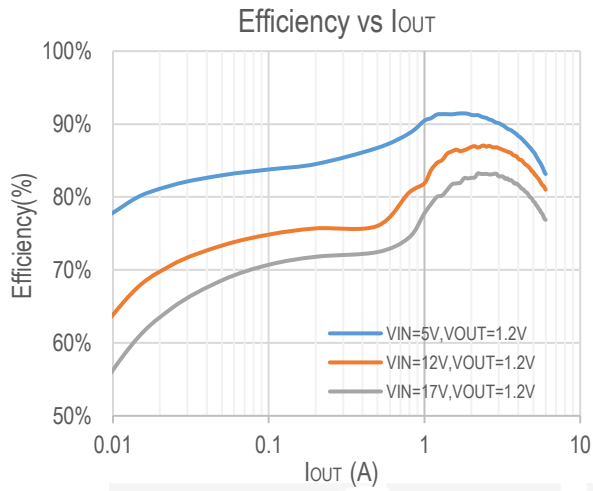

Figure 2: Functional Block Diagram

TYPICAL CHARACTERISTICS



Output Ripple

(V_{IN}=12V, V_{OUT}=3.3V, I_{OUT}=0A)

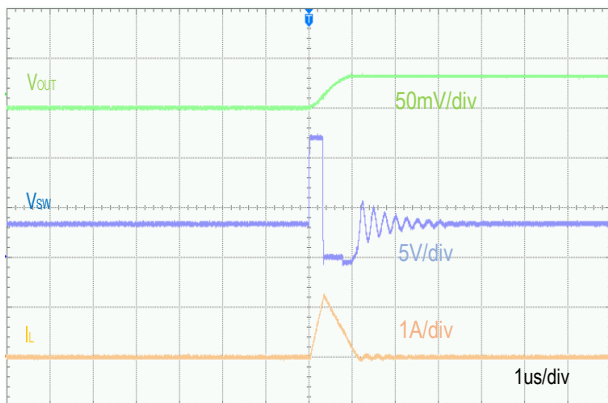

Output Ripple

(V_{IN}=12V, V_{OUT}=3.3V, I_{OUT}=6A)

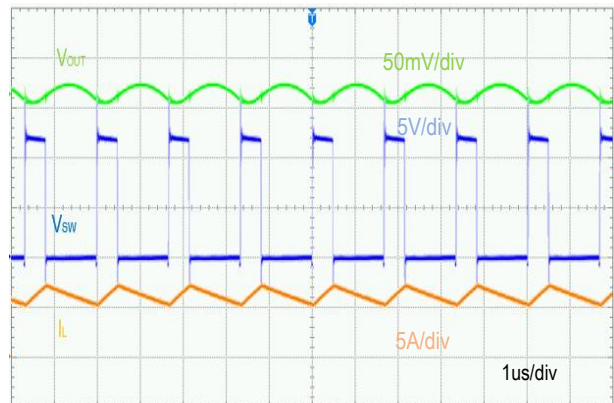

TYPICAL CHARACTERISTICS (cont')

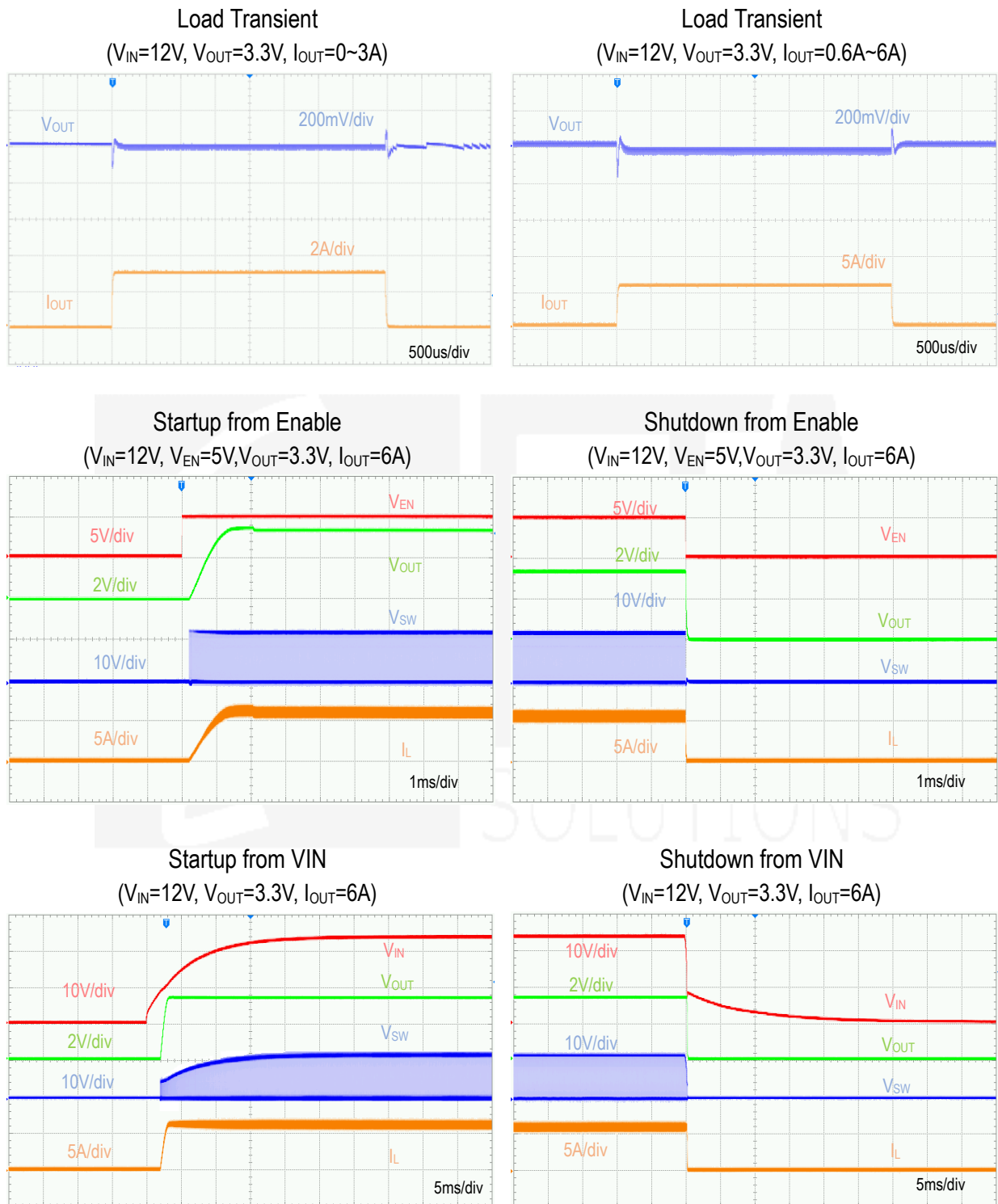

FEATURE DESCRIPTION

ETA8156 is a synchronous buck regulator ICs that integrates an adaptive COT control, top and bottom switches on the same die to minimize the switching transition loss and conduction loss.

ETA8156 is a wide input range, high-efficiency and high frequency DC-to-DC step-down switching regulator, capable of delivering up to 6A output current. It adopts an adaptive COT control scheme that enables very fast transient response and provides a very smooth transition when the output varies from light load to heavy load. It compares the sum of the FB voltage and a ripple voltage that mimics the voltage due to the output ESR and capacitance. The constant-on-time timer varies with line to achieve relative constant switching frequency across line.

Light Load Operation

Traditionally, a fixed constant frequency PWM DC-DC regulator always switches even when the output load is small. When energy is shuffling back and forth through the power MOSFET, power is lost due to the finite RDS(ON) of the MOSFET and parasitic capacitances. At light load, this loss is prominent and efficiency is therefore very low. ETA8156 goes into a power save mode during light load, thereby extending the range of high efficiency operation.

Enable

EN is a digital control pin that turns the ETA8156 on and off. Driving EN high to turn on the regulator, low to turn off. An internal 1MΩ resistor from EN pin to GND allows EN to float to shut down the chip. Connecting the EN pin through a pull up resistor or shorted EN to IN will automatically turn on the chip whenever plug in IN.

Over Current Protection and Hiccup

ETA8156 has a cycle-by-cycle over current limit for both inductor current peak value and inductor current valley value. Meanwhile both inductor currents during LS_FET ON or HS_FET ON are monitored. During LS_FET on, sensed inductor current is monitored by a valley current limit comparator. HS_FET always wait until valley current limit disappear to be on again. Once, HS_FET is ON, it will be immediately OFF whenever max on time or peak current limit is reached.

When the output voltage drop until FB falls below UV threshold (70% V_{NORMAL}), the ETA8156 will enter hiccup mode. It will turn off the chip immediately for 6ms. After that, it will try to re-starts as normal for 2ms. After 2ms, if FB is still below UV threshold, then the chip enters hiccup mode again. If FB is higher than UV threshold, it will enter the normal mode.

Over-Temperature Protection

Thermal protection disables the output when the junction temperature rises to approximately 155°C, allowing the device to cool down. When the junction temperature cools to approximately 110°C, the output circuitry is again

enabled. Depending on power dissipation, thermal resistance, and ambient temperature, the thermal protection circuit may cycle on and off.

This cycling limits regulator dissipation, protecting the device from damage as a result of overheating.

OUTPUT VOLTAGE CONFIGURATION

ETA8156 regulator is programmed using an external resistor divider. The output voltage is calculated using below equation.

$$V_{OUT} = V_{FB} \times \frac{R_1 + R_2}{R_2}$$

Resistors R2 has to be between 1KΩ to 24KΩ and thus R1 is calculated by following equation.

PCB LAYOUT GUIDE

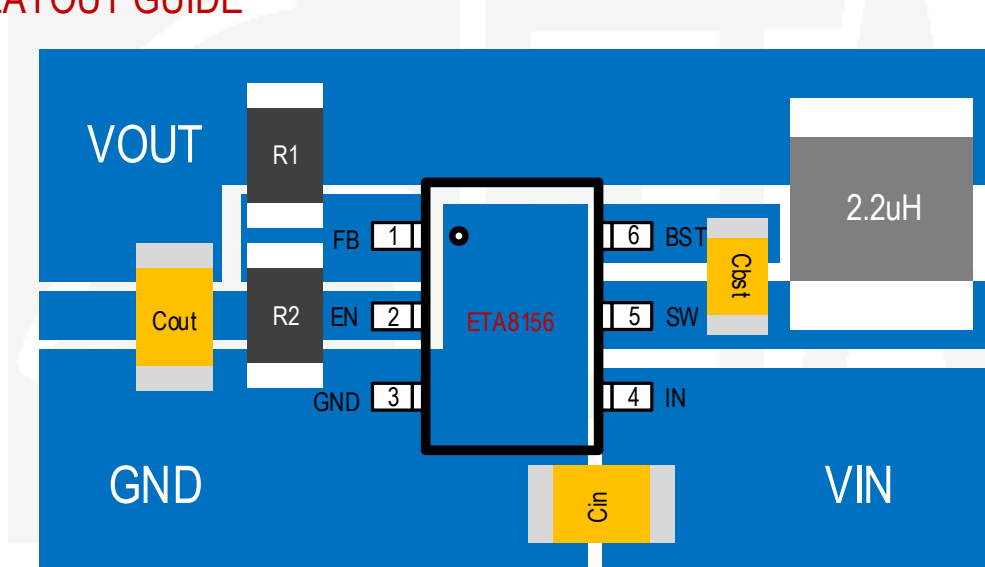

PACKAGE OUTLINE

Package: FCTSOT23-6

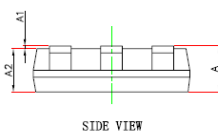
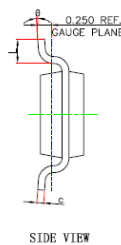
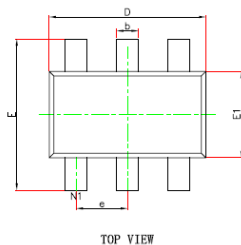

Symbol	Dimensions In Millimeters		Dimensions In Inches	
	Min	Max	Min	Max
A	-----	1.100	-----	0.043
A1	0.000	0.100	0.000	0.004
A2	0.700	1.000	0.028	0.039
D	2.850	2.950	0.112	0.116
E	2.650	2.950	0.104	0.116
E1	1.550	1.650	0.061	0.065
b	0.300	0.500	0.012	0.020
c	0.080	0.200	0.003	0.008
e	0.950(BSC)		0.037(BSC)	
L	0.300	0.600	0.012	0.024
θ	0°	8°	0°	8°

TAPE AND REEL INFORMATION

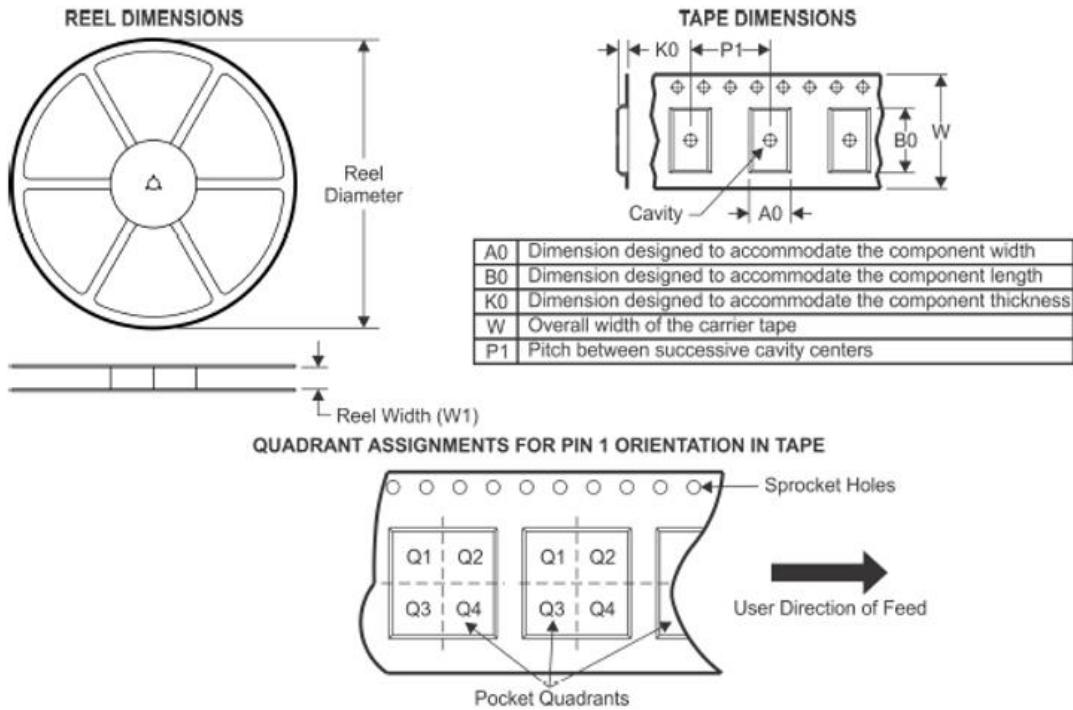

Device	Package Type	Pins	SPQ	Reel Diameter (mm)	Reel Width W1 (mm)	A0 (mm)	B0 (mm)	K0 (mm)	P1 (mm)	W (mm)	Pin1 Quadrant
ETA8156FT2G	FCTSOT23-6	6	3000	178	8.4	3.1	3.1	1.3	4	8	Q3

X-ON Electronics

Largest Supplier of Electrical and Electronic Components

Click to view similar products for [Isolated DC/DC Converters](#) category:

Click to view products by [etasolution](#) manufacturer:

Other Similar products are found below :

[PSL486-7LR](#) [Q48T30020-NBB0](#) [JAHW100Y1](#) [SPB05C-12](#) [SQ24S15033-PS0S](#) [CE-1003](#) [CE-1004](#) [MAU228](#) [J80-0041NL](#) [DFC15U48D15](#)
[XGS-1205](#) [06322](#) [SPB05B-15](#) [L-DA20](#) [DCG40-5G](#) [XKS-2405](#) [DPA423R](#) [vi-m13-cw-03](#) [VI-L53-CV](#) [24IBX15-50-0ZG](#) [HZZ01204-G](#)
[SPU02L-09](#) [SPU02M-09](#) [SPU02N-09](#) [QUINT4-BUFFER/24DC/40](#) [QUINT4-CAP/24DC/5/4KJ](#) [73-551-5039I](#) [DFC15U48D15G](#) [SEN-6471-](#)
[1EM](#) [AHV2815DF/HBB](#) [MI-LC21-IX](#) [PAH-48/8.5-D48NB1-C](#) [BM3020-7A](#) [QRS2050P025K00](#) [CM2320-9EG](#) [SKMW15F-05](#)
[V300A28H400BF3](#) [TEN 15-1223](#) [TEQ 100-2418WIR](#) [TEQ 160-7218WIR](#) [R05C05TE05S-R](#) [HQA2W085W033V-N07-S](#) [AM1SS-2405SJZ](#)
[AM2DS-1224SJZ](#) [AM2DS-2405DJZ](#) [AM10SBO-4824SNZ-B](#) [AM15E-2405S-NZ](#) [AM2DS-1212SJZ](#) [AM30SBO-4805SNZ-B](#)
[LT8301ES5#WTRPBF](#)