

Ultra Low Power PMU with 16V Linear Charger and 5V Boost Converter

DESCRIPTION

ETA9697 is an ultra low power PMU with 2 channels: a 16V single cell Li⁺ battery linear charger and a 5V Boost synchronous converter with true-shutoff function. The linear charger fully integrated constant current (CC) / constant voltage (CV) control module and charge FET, with minimal external devices. It also has pre-charge function for trickle charging deeply discharged battery and its fast charge current can be programmed by an external resistor. When CV charge stage is entered, charge will be terminated once the charge current drops to 1/10 of the programmed value. A "STAT" pin is also available to indicate the charge status. And the low power 5V Boost converter is capable of delivering 0.4A current at 5V output. It can be shut down by pulling ENBST low, it will disconnect the output from the BAT to further decrease the system standby power. Its 1.4MHz switching frequency enable a very small external inductor with inductance as low as 2.2uH. The ETA9697, as a whole, is an ideal for the system solution that requires very low standby power and compact PCB board size.

ETA9697 is housed in a ESOP8 package.

FEATURES

- ◆ Ultra low IQ when standby, I_{bat}<5uA
- ◆ 16V input standoff voltage
- ◆ 4.2V charge termination voltage
- ◆ Charge current programmable, up to 1.2A
- ◆ Output Disconnect and SCP at 5V output
- ◆ 5V/0.4A Output Power
- ◆ Up to 94% Efficiency for Boost converter
- ◆ Functioning with NO BATTERY
- ◆ Logic Control Shutdown and Thermal shutdown
- ◆ ESOP8 Package

APPLICATIONS

- ◆ TWS BT earbuds charge case
- ◆ Bluetooth application
- ◆ Battery powered IOT module
- ◆ Power Bank

TYPICAL APPLICATION

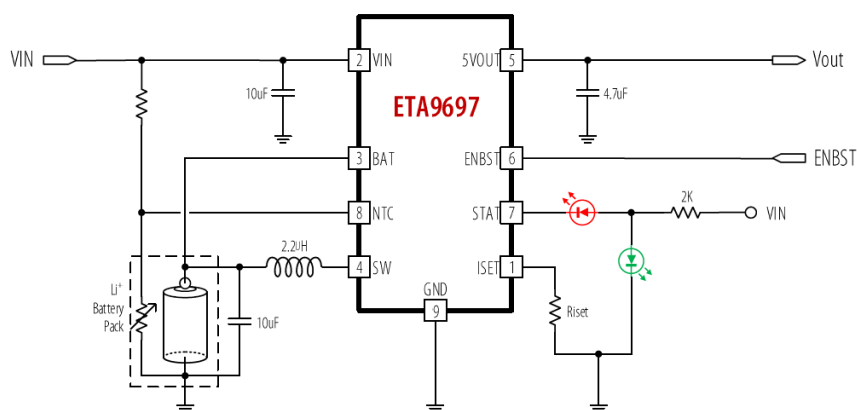

ORDERING INFORMATION

PART No.	PACKAGE	TOP MARK	Pcs/Reel
ETA9697E8A	ESOP8	ETA9697 <u>YWW2L</u>	4000

PIN CONFIGURATION

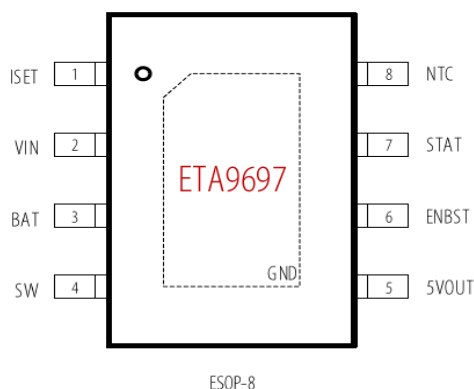

ABSOLUTE MAXIMUM RATINGS

(Note: Exceeding these limits may damage the device. Exposure to absolute maximum rating conditions for long periods may affect device reliability.)

VIN, BAT Voltage.....	-0.3V to 16V
SW, ISET, NTC, STAT, ENBST, 5VOUT Voltage.....	-0.3V to 6.5V
SW to ground current	Internally limited
Operating Temperature Range	-40°C to 85°C
Storage Temperature Range	-55°C to 150°C
Thermal Resistance	θ_{JA} θ_{JC}
ESOP8.....	50.....10.....°C/W
Lead Temperature (Soldering 10sec)	260°C
ESD HBM (Human Body Mode)	2KV
ESD MM (Machine Mode)	200V

ELECTRICAL CHARACTERISTICS

($V_{BAT}=3.8V$, $V_{IN}=5V$, $V_{OUT} = 5V$, unless otherwise specified. Typical values are at $T_A = 25^\circ C$.)

PARAMETER	CONDITIONS	MIN	TYP	MAX	UNITS
Linear Charger					
Input Standoff Voltage		16			V
Input Over-Voltage Protection Voltage	VIN rising, hys=0.3V	6.5	7	7.4	V
Input Voltage Range for Charging		4.25		6	V
Input Supply Current	Charge Mode		300	2000	μA
	Standby Mode (Charge Terminated)		65	100	μA
	Shutdown Mode (ISET Not Connected, EN=0, VIN<VBAT, or VIN<VULO)		25	50	μA
Regulated Output (Float) Voltage	Rset = 10K, IBAT = 40mA	4.16	4.2	4.24	V
BAT Pin Current	Rset = 10K, Current Mode	90	100	110	mA
	Rset = 2K, Current Mode	432	480	528	mA
	Rset = 1K, Current Mode	820	920	1020	mA
Trickle Charge Current	VBAT < VTRIKL, Rset = 2K	20	50	110	mA
Trickle Charge Threshold Voltage	VBAT Rising	2.75	2.93	3.1	V
Trickle Charge Hysteresis Voltage		100	130	165	mV
VIN Under-voltage Lockout Threshold	From VIN Low to High	3.05	3.35	3.6	V
VIN Under-voltage Lockout Hysteresis		0.4	0.55	0.65	V

PARAMETER	CONDITIONS	MIN	TYP	MAX	UNITS
VIN-VBAT Lockout Threshold Voltage	VIN from Low to High	50	100	140	mV
	VIN from High to Low	5	30		mV
C/10 Termination Current Threshold		0.085	0.1	0.115	mA/mA
ISET Pin Voltage	Current Mode, VBAT=4V		1		V
STAT Pin Weak Pull-Down Current	V_STAT = 5V		0.1		μA
STAT Pin Output Low Voltage	I_STAT= 5mA		0.35	0.6	V
Recharge BAT Threshold Voltage	VFLOAT - VRECHRG	90	120	150	mV
Junction Temperature in Constant Temperature Mode			120		°C
Power FET "ON" Resistance (Between VCC and BAT)			0.5		ohm
Soft-Start Time	IBAT = 0 to IBAT =1000V/RSET		100		μs
Recharge Comparator Filter Time	VBAT High to Low	400	1000	2500	μs
Termination Comparator Filter Time	IBAT Falling Below ICHG/10	400	1000	2500	μs
ISET Pin Pull-Up Current			1		μA
NTC Threshold, Cold	Charger Suspended		80	83	% VIN
NTC Threshold, Hot	Charger Suspended	42	45		% VIN
NTC Threshold Hysteresis			2		% VIN
NTC Disable Threshold	Tie NTC to GND				
NTC Input Leakage			0	1	μA
Boost Converter					
Quiescent Current at BAT	V_ENBST=IN, Vbat=4V		2	5	μA
Shutdown Supply Current at ENBST	V_ENBST =GND		0.5		μA
VBAT Startup Voltage	I_OUT=1mA		0.8		V
BAT Operation Voltage	After Start-up	1.0		4.5	V
Output Voltage at 5V		4.85	5	5.15	V
Switching Frequency			1.4		MHz
NMOS Switch On Resistance	I_SW=100mA		220		mΩ
PMOS Switch On Resistance	I_SW=100mA		160		mΩ
SW Leakage Current	V_OUT=5.2V, V_EN=GND, V_SW=5.2V or V_SW= 0V			10	μA
NMOS Switch Current Limit			1		A
Start-up Current Limit			1		A
Short Circuit Hiccup time	ON		1.3		ms
	OFF		33		ms

PARAMETER	CONDITIONS	MIN	TYP	MAX	UNITS
ENBST Input Current	V _{EN} =5V or 0V	-1	0	1	μA
ENBST High Voltage	V _{OUT} =5V	1.2			V
ENBST low Voltage	V _{OUT} =5V			0.4	V
Thermal Shutdown	Rising, Hysteresis=25°C		160		°C

PIN DESCRIPTION

PIN #	NAME	DESCRIPTION
1	ISET	Program, Monitor the charge current and Shutdown. This pin set to 1V in constant-current mode. The charge current is programmed by connecting a 1% resistor (R _{set}), between ISET, to GND pin. The charge current can be calculated using the following formula: $I_{BAT} = \frac{1}{R_{set}} \times 1000 - \left(\frac{1}{3.6} \times \frac{1}{R_{set}} \times 1000 \right)^2$ The ISET pin can also be used to switch the charger to shutdown mode by disconnecting the program resistor from ground.
2	VIN	Input Supply Voltage. Bypass with a 10μF ceramic capacitor to GND
3	BAT	Connected to the battery positive terminal. Bypass with a 10uF ceramic capacitor to GND
4	SW	Inductor Connection. Connect an inductor Between SW and the regulator output.
5	5VOUT	Output pin. Bypass with a 4.7μF or larger ceramic capacitor closely between this pin and GND
6	ENBST	Enable pin for the Boost converter. Drive this pin high to enable the part, low to disable.
7	STAT	Open-Drain Output for In Charging flag, The STAT pin outputs low when the battery is in charging. Upon the completion of the charge cycle, it becomes high-impedence.
8	NTC	Battery Temperature Monitoring input pin. It sets the valid temperature operating range for battery charging.
9	GND	Ground

TYPICAL CHARACTERISTICS

(Typical values are at T_A = 25°C unless otherwise specified.)

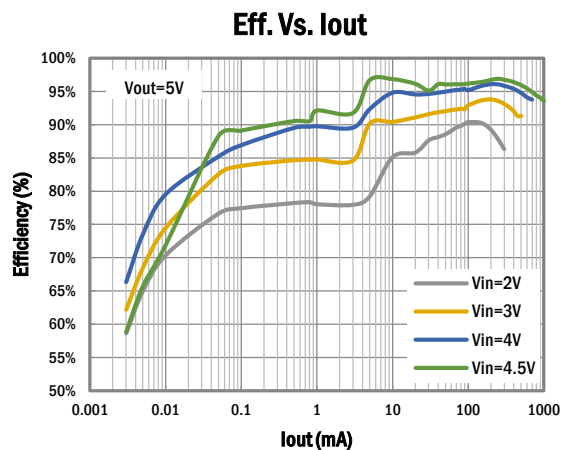
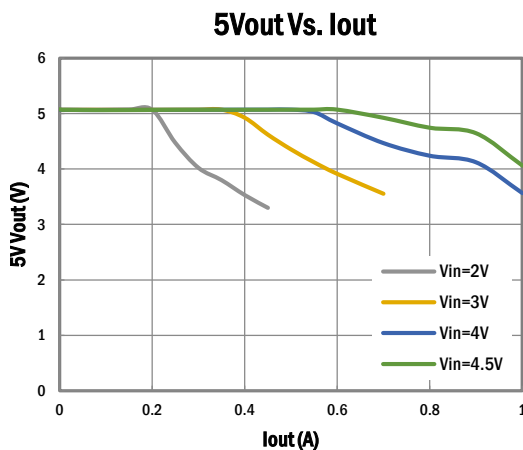

APPLICATION INFORMATION

ETA9697 is an ultra low power PMU with 2 channels: a 16V single cell Li⁺ battery linear charger and a 5V Boost synchronous converter with true-shutoff function.

Normal Charge Cycle

The ETA9697 initiates a charge cycle once the voltage at the VIN pin rises above the UVLO threshold level. A 1% precision resistor needs to be connected from the ISET pin to ground. If the voltage at the BAT pin is less than 2.9V, the charger enters trickle charge mode. In this mode, the charge current is reduced to nearly 1/10 the programmed value until the battery voltage is raised to a safe level for full current charging.

The charger switches to constant-current mode as the BAT pin voltage rises above 2.9V, the charge current is thus resumed to full programmed value. When the final float voltage (4.2V) is reached, the ETA9697 enters constant-voltage mode and the charge current begins to decrease until it drops to 1/10 of the preset value and ends the charge cycle¹

Programming Charge Current

The charge current is programmable by setting the value of a precision resistor connected from the ISET pin to ground. The charge current is 1000 times of the current out of the ISET pin. The charge current out of the BAT pin can be determined at any time by monitoring the ISET pin voltage using the following equation:

$$I_{BAT} = \frac{1}{R_{set}} \times 1000 - \left(\frac{1}{3.6} \times \frac{1}{R_{set}} \times 1000 \right)^2$$

Charge Termination

The ETA9697 keeps monitoring the ISET pin during the charging process. It terminates the charge cycle when the charge current falls to 1/10 the programmed value after the final float voltage is reached. When the ISET pin voltage falls below 100mV for longer than tTERM (typically 1ms), charging is terminated. The charge current is latched off and the ETA9697 enters standby mode, where the input supply current drops to 200μA. (Note: C/10 termination is disabled in trickle charging and thermal limiting modes).

During charging, the transient response of the circuit can cause the ISET pin to fall below 100mV temporarily before the battery is fully charged, thus can cause a premature termination of the charge cycle. A 1ms filter time on the termination comparator can prevent this from happening. Once the average charge current drops below 1/10 the programmed value, the ETA9697 terminates the charge cycle and ceases to provide any current through the BAT pin. In this state, all loads on the BAT pin must be supplied by the battery.

The ETA9697 constantly monitors the BAT pin voltage in standby mode and resume another charge cycle if this voltage drops below the recharge threshold. User can also manually restart a charge cycle in standby mode either by removing and then reapplied the input voltage or restart the charger using the ISET pin.

Charge Status Indicator

There are 2 different states of the charge status, one is IN CHRGING, and the other is CHARGING FINISHED. STAT is the pin to pull low during IN CHARGING status and become high impedance in CHARGING FINISHED status.

High Temperature Fold-back

Build-in feedback circuitry mechanism can reduce the value of the programmed charge current once the die temperature tends to rise above 100°C, hence prevents the temperature from further increase and ensure device safe operation.

Under-voltage Lockout (UVLO)

Build-in under-voltage lockout circuit monitors the input voltage and keeps the charger in shutdown mode until VIN rises above the under-voltage lockout threshold. The UVLO circuit has a built-in hysteresis of 500mV. Furthermore, to protect against reverse current in the power MOSFET, the UVLO circuit keeps the charger in shutdown mode if VIN falls to within 30mV of the battery voltage. If the UVLO comparator is tripped, the charger will not come out of shutdown mode until VIN rises 100mV above the battery voltage.

Automatic Recharge

After the termination of the charge cycle, the ETA9697 constantly monitors the BAT pin voltage and starts a new charge cycle when the battery voltage falls below 4.08V, keeping the battery at fully charged condition. ISET pin output enters a strong pull-down state during recharge cycles.

Battery Temperature Monitoring

ETA9697 continuously monitors temperature by measuring the voltage of NTC pin. A negative or positive temperature coefficient thermistor and an external voltage divider typically develop this voltage. ETA9697 compares this voltage against its internal 80%VIN and 45%VIN thresholds to determine if charging is allowed. The temperature sensing circuit is immune to any fluctuation in VIN, since both the external voltage divider and the internal thresholds 80%VIN and 45%VIN are referenced to VIN. If the NTC pin is connected to GND will disable the temperature-sensing feature.

Ultra low current consumption at Light Load Boost Operation

Traditionally, a fixed constant frequency PWM DC/DC regulator always switches even when the output load is small. When energy is shuffling back and forth through the power MOSFETs, power is lost due to the finite RDSOns of the MOSFETs and parasitic capacitances. At light load, this loss is prominent and efficiency is therefore very low. ETA9697 employs a proprietary control scheme that improves efficiency in this situation by enabling the device into a power saving mode during light load and the no load quiescent current can be lower than 5μA.

Output (5VOUT pin) Short-Circuit Protection

Unlike most step-up converters, the ETA9697 allows for short circuits on the output. In the event of a short circuit, the device first turns off the NMOS when the sensed current reaches the current limit. When OUT drops below IN, the device then enters a linear charge period with the current limited same as with the start-up period. In addition, the thermal shutdown circuits disable switching if the die temperature rises above 160°C.

PCB GUIDELINES

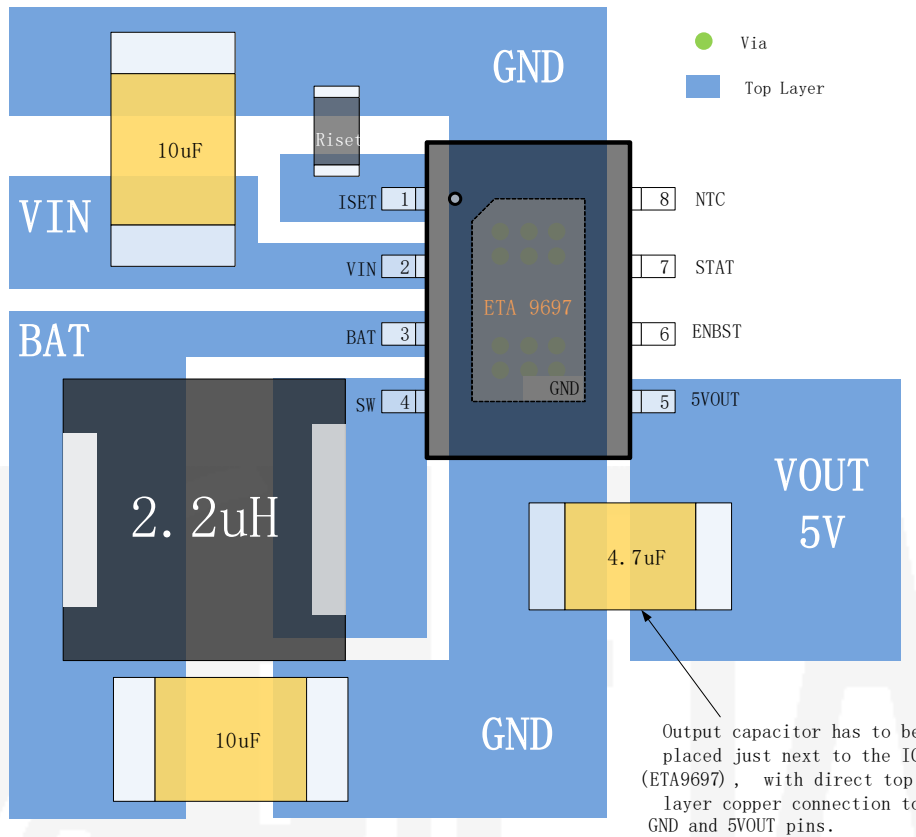

PACKAGE OUTLINE

Package: ESOP8

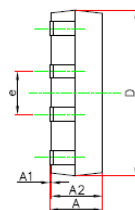
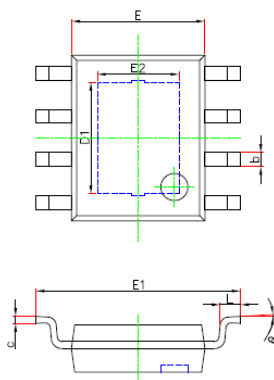

Symbol	Dimensions In Millimeters		Dimensions In Inches	
	Min.	Max.	Min.	Max.
A	1.300	1.700	0.051	0.067
A1	0.000	0.100	0.000	0.004
A2	1.350	1.550	0.053	0.061
b	0.330	0.510	0.013	0.020
c	0.170	0.250	0.007	0.010
D	4.700	5.100	0.185	0.201
D1	3.202	3.402	0.126	0.134
E	3.800	4.000	0.150	0.157
E1	5.800	6.200	0.228	0.244
E2	2.313	2.513	0.091	0.099
e	1.270(BSC)		0.050(BSC)	
L	0.400	1.270	0.016	0.050
θ	0°		8°	

X-ON Electronics

Largest Supplier of Electrical and Electronic Components

Click to view similar products for [Isolated DC/DC Converters](#) category:

Click to view products by [etasolution](#) manufacturer:

Other Similar products are found below :

[PSL486-7LR](#) [Q48T30020-NBB0](#) [JAHW100Y1](#) [SPB05C-12](#) [SQ24S15033-PS0S](#) [CE-1003](#) [CE-1004](#) [MAU228](#) [J80-0041NL](#) [DFC15U48D15](#)
[XGS-1205](#) [06322](#) [SPB05B-15](#) [L-DA20](#) [DCG40-5G](#) [XKS-2405](#) [DPA423R](#) [vi-m13-cw-03](#) [VI-L53-CV](#) [24IBX15-50-0ZG](#) [HZZ01204-G](#)
[SPU02L-09](#) [SPU02M-09](#) [SPU02N-09](#) [QUINT4-BUFFER/24DC/40](#) [QUINT4-CAP/24DC/5/4KJ](#) [73-551-5039I](#) [DFC15U48D15G](#) [SEN-6471-](#)
[1EM](#) [AHV2815DF/HBB](#) [MI-LC21-IX](#) [PAH-48/8.5-D48NB1-C](#) [BM3020-7A](#) [QRS2050P025K00](#) [CM2320-9EG](#) [SKMW15F-05](#)
[V300A28H400BF3](#) [TEN 15-1223](#) [TEQ 100-2418WIR](#) [TEQ 160-7218WIR](#) [R05C05TE05S-R](#) [HQA2W085W033V-N07-S](#) [AM1SS-2405SJZ](#)
[AM2DS-1224SJZ](#) [AM2DS-2405DJZ](#) [AM10SBO-4824SNZ-B](#) [AM15E-2405S-NZ](#) [AM2DS-1212SJZ](#) [AM30SBO-4805SNZ-B](#)
[LT8301ES5#WTRPBF](#)