

### N-Channel Enhancement-Mode MOSFET (30V,45A)

#### PRODUCT SUMMARY

$V_{DSS}$	$I_D$	$R_{DS(on)}$ (m $\Omega$ )Max
30V	45A	7.9 @ $V_{GS} = 10V, I_D=20A$
		12 @ $V_{GS} = 4.5V, I_D=10A$

#### Features

- Super high density cell design for extremely low RDS(ON)
- Exceptional on-resistance and maximum DC current capability
- Fast Switching □
- Lead (Pb) -free and halogen-free

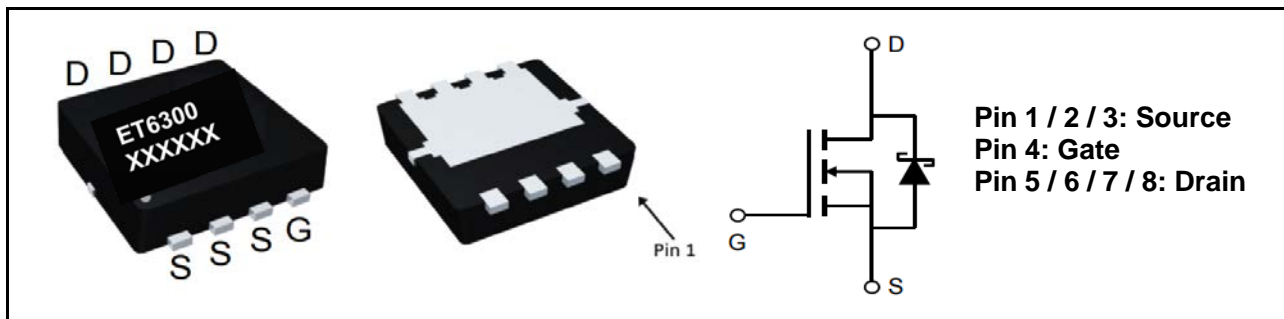

#### Absolute Maximum Ratings ( $T_A=25^\circ\text{C}$ , unless otherwise noted)

Symbol	Parameter	Ratings	Units
$V_{DS}$	Drain-Source Voltage	30	V
$V_{GS}$	Gate-Source Voltage	$\pm 20$	V
$I_D$	Drain Current (Continuous) @ $T_A=25^\circ\text{C}$	45	A
	Drain Current (Continuous) @ $T_A=75^\circ\text{C}$	28	A
$I_{DM}$	Drain Current (Pulsed) <sup>a</sup>	180	A
$P_D$	Total Power Dissipation @ $T_A=25^\circ\text{C}$	28	W
	Total Power Dissipation @ $T_A=75^\circ\text{C}$	20	W
$I_S$	Maximum Diode Forward Current	45	A
$T_j, T_{stg}$	Operating Junction and Storage Temperature Range	-55 to +150	$^\circ\text{C}$
$R_{QJA}$	Thermal Resistance Junction to Ambient (PCB mounted) <sup>b</sup>	35	$^\circ\text{C/W}$

a: Repetitive Rating: Pulse width limited by the maximum junction temperature.

b: 1-in<sup>2</sup> 2oz Cu PCB board

### Electrical Characteristics ( $T_A=25^\circ\text{C}$ , unless otherwise noted)

Symbol	Characteristic	Test Conditions	Min.	Typ.	Max.	Unit
<b>• Off Characteristics</b>						
$BV_{DSS}$	Drain-Source Breakdown Voltage	$V_{GS}=0V, I_D=250\mu A$	30	-	-	V
$I_{DSS}$	Zero Gate Voltage Drain Current	$V_{DS}=30V, V_{GS}=0V$	-	-	1	$\mu A$
$I_{GSS}$	Gate-Body Leakage Current	$V_{GS}=\pm 20V, V_{DS}=0V$	-	-	$\pm 100$	nA
<b>• On Characteristics</b>						
$V_{GS(th)}$	Gate Threshold Voltage	$V_{DS}=V_{GS}, I_D=250\mu A$	1.0	1.9	2.5	V
$R_{DS(on)}$	Drain-Source On-State Resistance	$V_{GS}=4.5V, I_D=5A$	-	12	15	m $\Omega$
		$V_{GS}=10V, I_D=10A$	-	7.9	10	
<b>• Dynamic Characteristics</b>						
$C_{iss}$	Input Capacitance	$V_{DS}=15V, V_{GS}=0V, f=1\text{MHz}$	-	860	-	PF
$C_{oss}$	Output Capacitance		-	140	-	
$C_{rss}$	Reverse Transfer Capacitance		-	105	-	
<b>• Switching Characteristics</b>						
$Q_g$	Total Gate Charge	$V_{DS}=15V, I_D=20A, V_{GS}=10V$	-	19	-	nC
$Q_{gs}$	Gate-Source Charge		-	4.3	-	
$Q_{gd}$	Gate-Drain Charge		-	6.5	-	
$t_{d(on)}$	Turn-on Delay Time	$V_{DD}=15V, R_L=15\Omega, I_D=20A, V_{GEN}=10V, R_G=6\Omega$	-	6	-	nS
$t_r$	Turn-on Rise Time		-	5	-	
$t_{d(off)}$	Turn-off Delay Time		-	25	-	
$t_f$	Turn-off Fall Time		-	7	-	
<b>• Drain-Source Diode Characteristics</b>						
$V_{SD}$	Drain-Source Diode Forward	$V_{GS}=0V, I_S=20A$	-	-	1.2	V

Note: Pulse Test: Pulse Width  $\leq 300\mu s$ , Duty Cycle  $\leq 2\%$

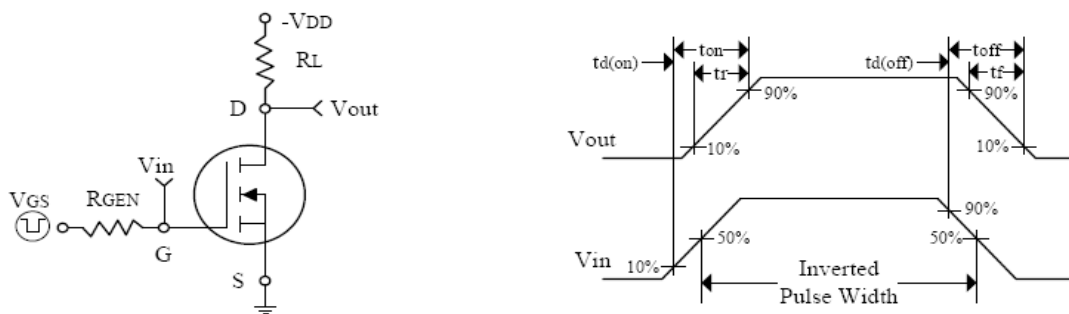

Switching Test Circuit and Switching Waveforms

### Typical Characteristics Curves (Ta=25°C, unless otherwise note)

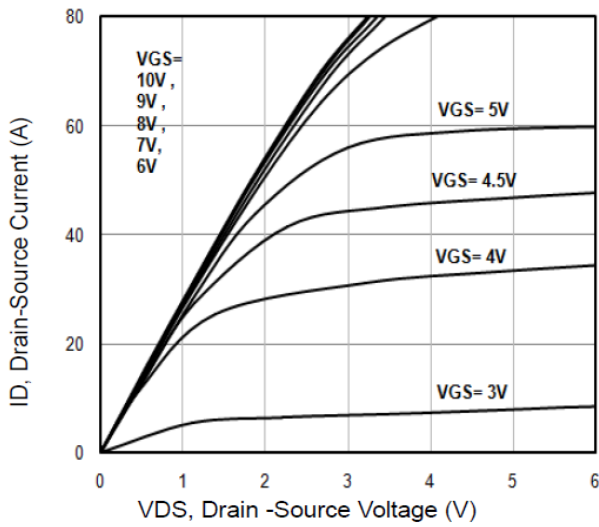

**Fig1.** Typical Output Characteristics

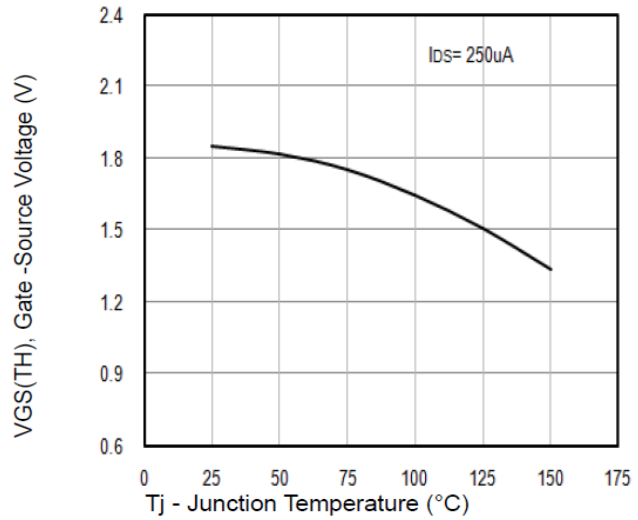

**Fig2.** VGS(TH) Gate-Source Voltage Vs. Tj

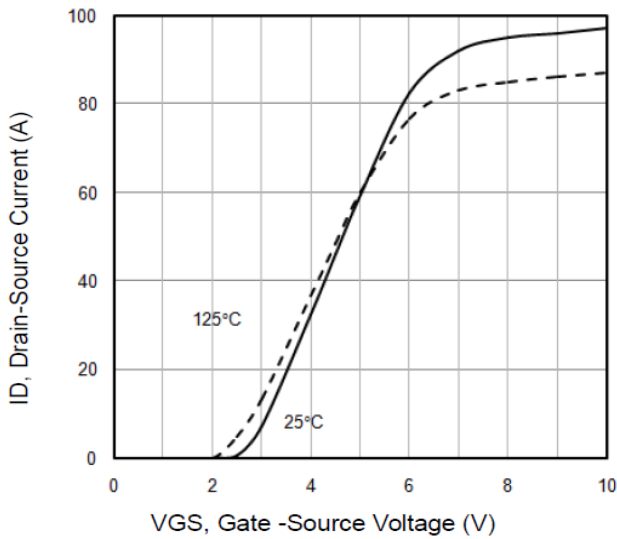

**Fig3.** Typical Transfer Characteristics

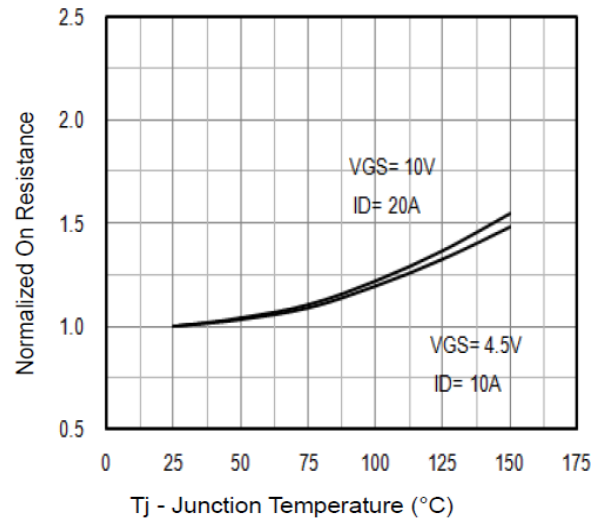

**Fig4.** Normalized On-Resistance Vs. Tj

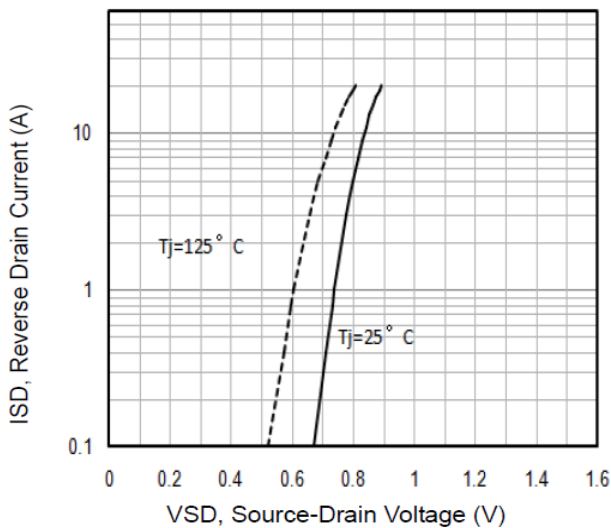

**Fig5.** Typical Source-Drain Diode Forward Voltage

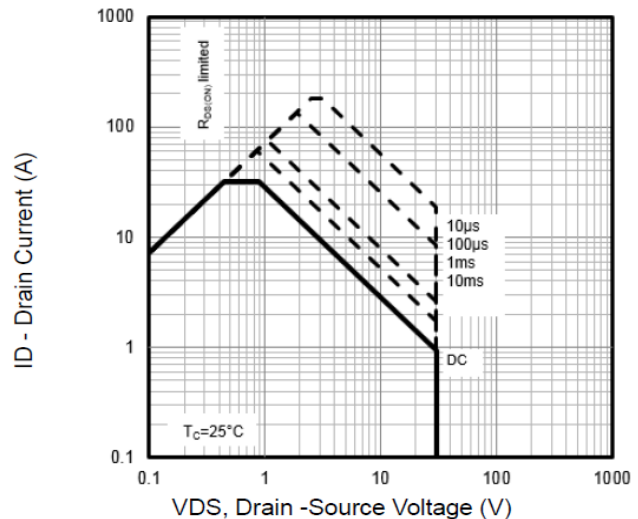

**Fig6.** Maximum Safe Operating Area

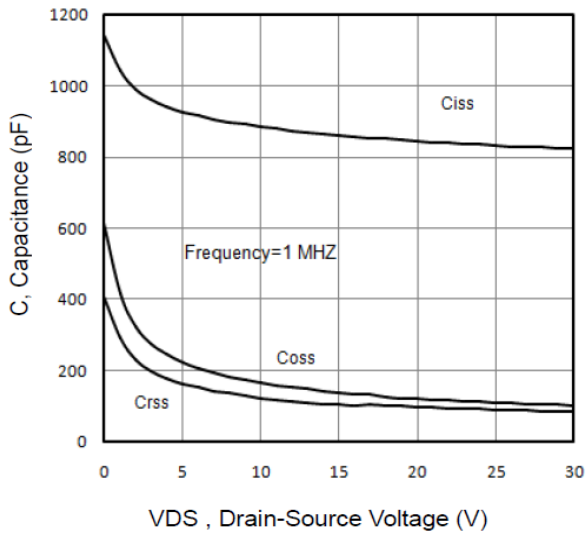

Fig7. Typical Capacitance Vs. Drain-Source Voltage

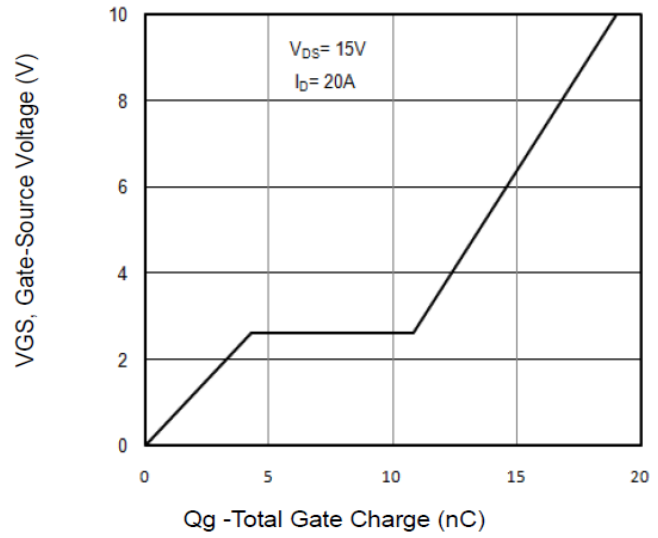

Fig8. Typical Gate Charge Vs. Gate-Source Voltage

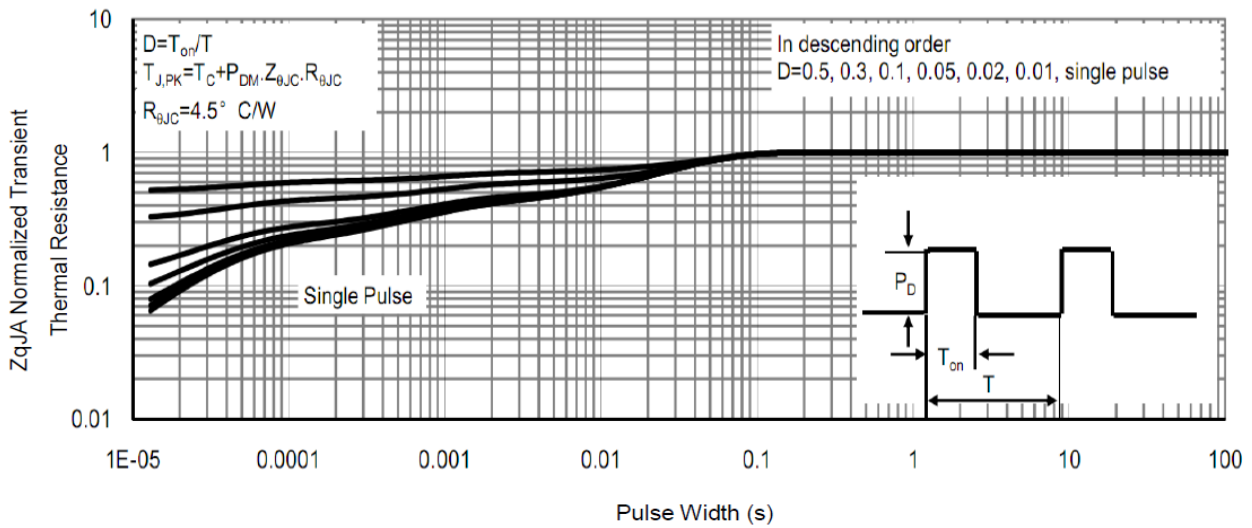
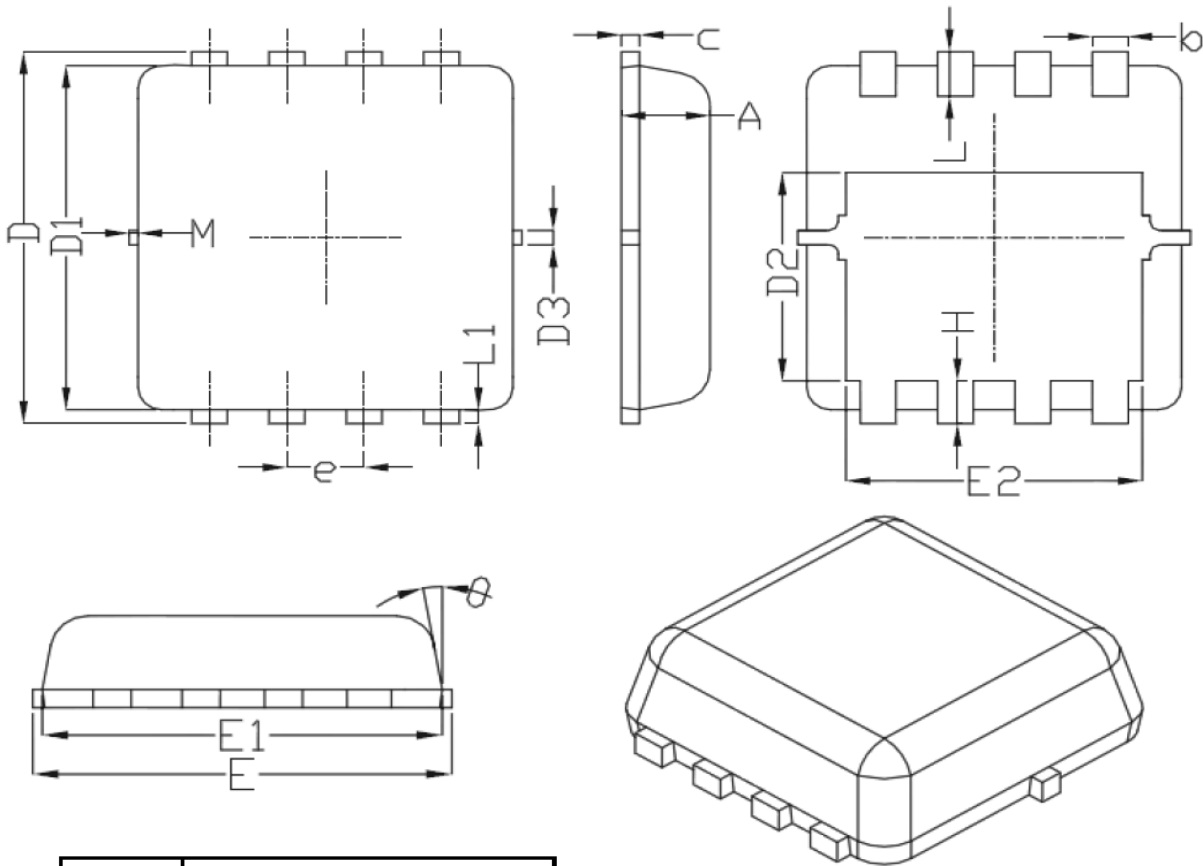

Fig9. Normalized Maximum Transient Thermal Impedance

### PDFN3333 PACKAGE OUTLINE DIMENSIONS



Symbol	DIMENSIONS ( unit : mm )		
	Min	Typ	Max
A	0.7	0.75	0.8
b	0.25	0.3	0.35
C	0.1	0.15	0.25
D	3.25	3.35	3.45
D1	3	3.1	3.2
D2	1.78	1.88	1.98
D3	--	0.13	--
E	3.2	3.3	3.4
E1	3	3.15	3.2
E2	2.39	2.49	2.59
e	0.65 BSC		
H	0.3	0.39	0.5
L	0.3	0.4	0.5
L1	--	0.13	--
θ	--	10°	12°
M	*	*	0.15

## X-ON Electronics

Largest Supplier of Electrical and Electronic Components

*Click to view similar products for [MOSFET](#) category:*

*Click to view products by [Eternal Semiconductor](#) manufacturer:*

Other Similar products are found below :

[614233C](#) [648584F](#) [MCH3443-TL-E](#) [MCH6422-TL-E](#) [FDPF9N50NZ](#) [NTNS3A92PZT5G](#) [IRFD120](#) [IRFF430](#) [JANTX2N5237](#) [2N7000](#)  
[AOD464](#) [2SK2267\(Q\)](#) [2SK2545\(Q,T\)](#) [405094E](#) [423220D](#) [MIC4420CM-TR](#) [VN1206L](#) [614234A](#) [715780A](#) [751625C](#)  
[IPS70R2K0CEAKMA1](#) [BSF024N03LT3 G](#) [PSMN4R2-30MLD](#) [TK31J60W5,S1VQ\(O](#) [2SK2614\(TE16L1,Q\)](#) [DMN1017UCP3-7](#)  
[EFC2J004NUZTDG](#) [FCAB21350L1](#) [P85W28HP2F-7071](#) [DMN1053UCP4-7](#) [NTE2384](#) [NTE2969](#) [NTE6400A](#) [DMC2700UDMQ-7](#)  
[DMN2080UCB4-7](#) [DMN61D9UWQ-13](#) [US6M2GTR](#) [DMN31D5UDJ-7](#) [SSM6P54TU,LF](#) [DMP22D4UFO-7B](#) [IPS60R3K4CEAKMA1](#)  
[DMN1006UCA6-7](#) [DMN16M9UCA6-7](#) [STF5N65M6](#) [IRF40H233XTMA1](#) [IPSA70R950CEAKMA1](#) [IPSA70R2K0CEAKMA1](#) [STU5N65M6](#)  
[C3M0021120D](#) [DMN6022SSD-13](#)