

## General Description

The EA2208L is a constant frequency, current mode step-up converter intended for small, low power applications. The EA2208L switches at 1.2MHz and allows the use of tiny, low cost capacitors and inductors 2mm or less in height. Internal soft-start results in small inrush current and extends battery life.

The EA2208L features automatic shifting to pulse frequency modulation mode at light loads. The EA2208L includes under-voltage lockout, current limiting, and thermal overload protection to prevent damage in the event of an output overload. The EA2208L is available in a small 6 pin SOT-23 package.

## Features

- ▶ Built-in Low  $R_{DS(ON)}$  Power-MOSFETS
- ▶ 2.2V to 16V Input Voltage Range
- ▶ Fixed 1.2MHz Switching Frequency
- ▶ Internal 2.5A Switch Current Limit
- ▶ Adjustable Over Current Protection: 0.5A to 2.5A
- ▶ Adjustable Output Voltage
- ▶ Over Voltage Protection
- ▶ Internal Compensation
- ▶ Up to 16V Output Voltage
- ▶ Automatic Pulse Frequency Modulation Mode at Light Loads
- ▶ Up to 93% Efficiency
- ▶ Available in SOT23-6 Package

## Applications

- ▶ Battery-Powered Equipment
- ▶ Set-Top-Box
- ▶ LCD TVs and Flat TVs
- ▶ DSL and Cable Modems



## Pin Configurations



**Pin Description**

Pin Name	Function Description	Pin No.
SWITCH	Power switch output pin. Connect SWITCH pin to power inductor and output rectifier.	1
GND	Ground pin.	2
FBK	Feedback input. Connect FBK pin and GND pin with voltage dividing resistors to set the output voltage.	3
RUN	The device turns on/turns off control input. Don't leave this pin floating.	4
PWR	The EA2208L power input pin. It is recommended to use a 22uF MLCC capacitor between PWR pin and GND pin. The ceramic capacitor must be placed as close to the PWR pin as possible to avoid noise interference.	5
OC	Adjustable Current Limit (Floating Available).	6

**Function Block Diagram**

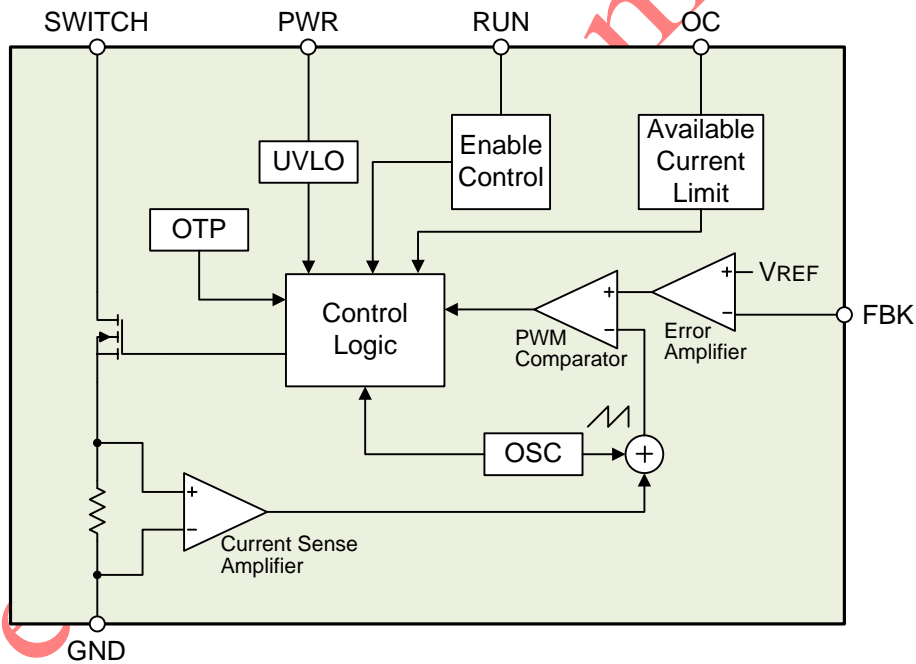

Figure 1. EA2208L internal function block diagram

### Absolute Maximum Ratings

Parameter	Value
Input Supply Voltage ( $V_{PWR}$ )	-0.3V to +18V
RUN Pin Input Voltage ( $V_{RUN}$ )	-0.3V to +18V
SWITCH Pin Voltage ( $V_{SWITCH}$ )	-0.3V to +22V
FBK Pin Voltage ( $V_{FBK}$ )	-0.3V to +6V
Ambient Temperature operating Range ( $T_A$ )	-40°C to +85°C
Maximum Junction Temperature ( $T_{Jmax}$ )	+160°C
Lead Temperature (Soldering, 10 sec)	+260°C
Storage Temperature Range ( $T_S$ )	-65°C to +150°C

Note (1): Stresses beyond those listed under "Absolute Maximum Ratings" may cause permanent damage to the device. Exposure to "Absolute Maximum Ratings" conditions for extended periods may affect device reliability and lifetime.

### Package Thermal Characteristics

Parameter	Value
SOT-23-6 Thermal Resistance ( $\theta_{JC}$ )	130°C/W
SOT-23-6 Thermal Resistance ( $\theta_{JA}$ )	250°C/W
SOT-23-6 Power Dissipation at $T_A=25^\circ\text{C}$ ( $P_{Dmax}$ )	0.54W

Note (1):  $P_{Dmax}$  is calculated according to the formula:  $P_{Dmax}=(T_{Jmax}-T_A)/\theta_{JA}$ .

### Recommended Operating Conditions

Parameter	Value
Input Supply Voltage ( $V_{PWR}$ )	+2.2V to +16V

**Electrical Characteristics**

$V_{PWR}=5V$ ,  $V_{RUN}=5V$ ,  $T_A=25^{\circ}C$ , unless otherwise noted

Parameter	Symbol	Test Conditions	Min	Typ	Max	Unit
Input Voltage	$V_{PWR}$		2.2		16	V
Shutdown Supply Current	$I_{SD}$	$V_{RUN} = 0V$		0.1	1	$\mu A$
Quiescent Current (PFM)	$I_{Q-PFM}$	$V_{FBK} = 0.7V$ , Non switching		100	200	$\mu A$
Quiescent Current (PWM)	$I_{Q-PWM}$	$V_{FBK} = 0.5V$ , switching	0.4	1.0	1.5	mA
UVLO Threshold	$V_{UVLO}$	$V_{PWR}$ Rising			2.2	V
UVLO Hysteresis	$V_{UV-HYST}$			0.1		V
Reference Voltage	$V_{REF}$		0.588	0.6	0.612	V
FBK Input Bias Current	$I_{FBK}$	$V_{FBK} = 0.6V$	-50	-10		nA
Switching Frequency	$F_{SW}$			1.2		MHz
Maximum Duty Cycle	$D_{MAX}$		90			%
NMOS On-Resistance	$R_{DS(ON)}$			80	150	m $\Omega$
NMOS Current Limit	$I_{LIM}$	$V_{PWR} = 5V$ , duty cycle = 50%		2.5		A
SWITCH Leakage Current	$I_{LEAK-SWITCH}$	$V_{SWITCH} = 20V$	-1		1	$\mu A$
RUN Pin Input Low Voltage	$V_{RUN-L}$				0.5	V
RUN Pin Input High Voltage	$V_{RUN-H}$		1.5			V
Adjustable OCP Current	$I_{OC}$	With external resistor 19K $\Omega$ ~96K $\Omega$	0.5		2.5	A
Thermal Shutdown Threshold	$T_{OTP}$			160		$^{\circ}C$

Note (1): MOSFET on-resistance specifications are guaranteed by correlation to wafer level measurements.

(2): Thermal shutdown specifications are guaranteed by correlation to the design and characteristics analysis.

**Application Circuit Diagram**

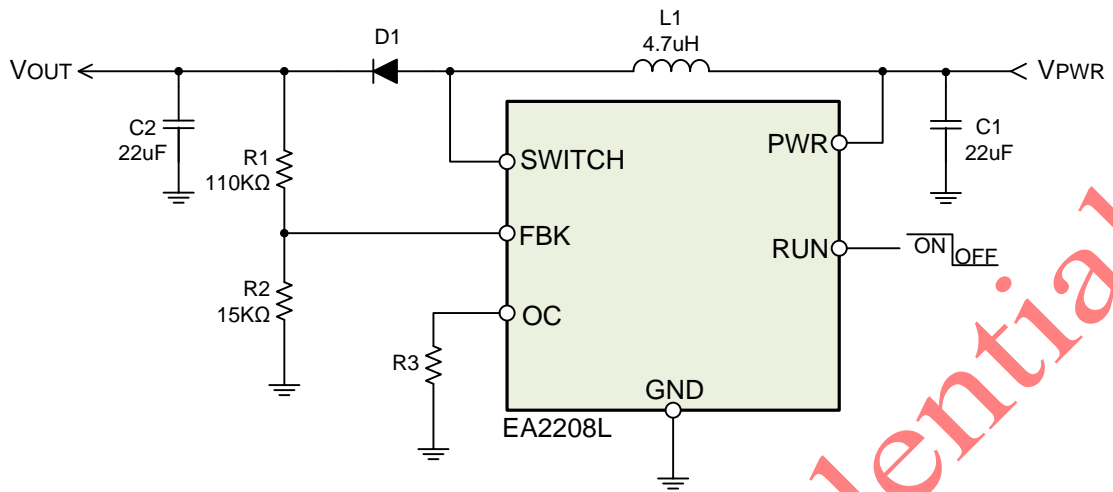

Figure 2. EA2208L typical application circuit diagram

**Ordering Information**

Part Number	Package Type	Packing Information
EA2208LT6R	SOT-23-6	Tape & Reel / 3000

Note (1): "T6": Package type code.  
 (2): "R": Tape & Reel.

Typical Operating Characteristics

L1=4.7uH, C1=C2=22uF, T<sub>A</sub>=25°C, unless otherwise noted

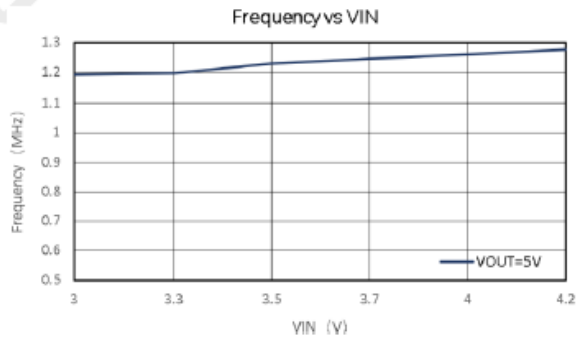
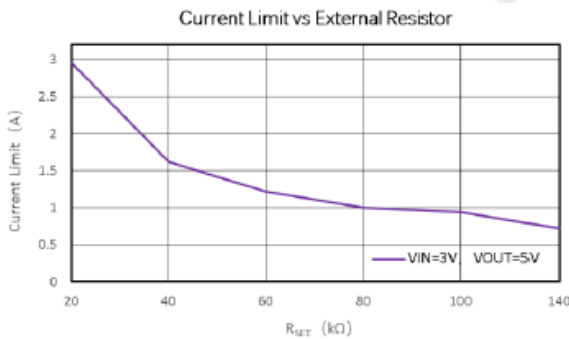
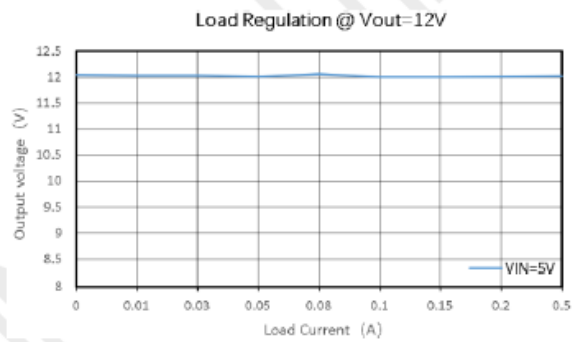
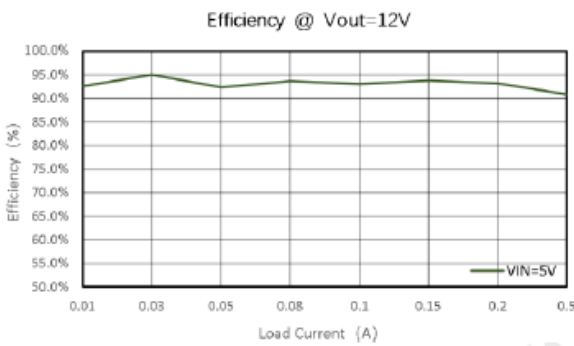
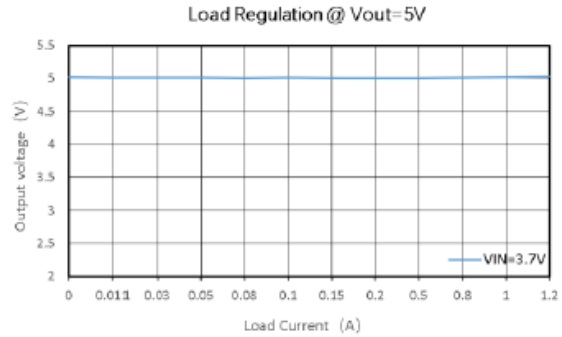
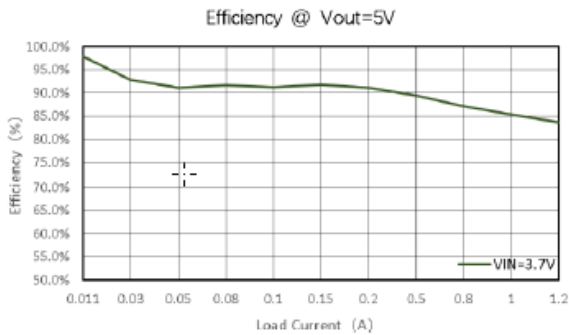

V<sub>IN</sub>=3.7V, V<sub>OUT</sub>=5V, I<sub>LOAD</sub>=0.5A

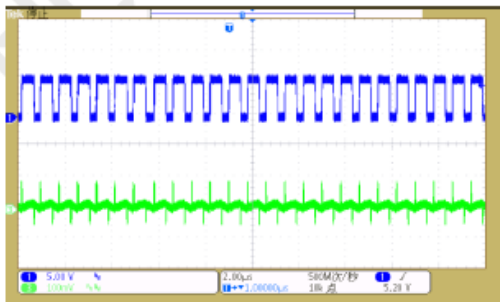

V<sub>IN</sub>=3.7V, V<sub>OUT</sub>=5V, I<sub>LOAD</sub>=1A

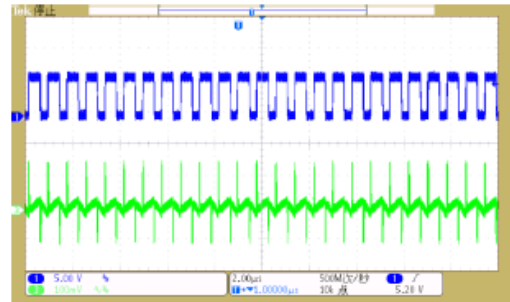

## **Application Information**

### **Output Voltage Setting**

The EA2208L output voltage can be set via a resistor divider (R1, R2). The output voltage is calculated by following equation:

$$V_{OUT} = 0.6 \times \frac{R1}{R2} + 0.6 \text{ V}$$

### **Current Limit Program**

A resistor between OC and GND pin programs peak switch current. The resistor value should be between 19KΩ to 96KΩ. The current limit will be set from 2.5A to 0.5A. Keep traces at this pin as short as possible. The OC pin can be floating and the current limit will be set by internal 2.5A current limit. To set the over current trip point according to the following equation:

$$I_{OC} = \frac{48000}{R3}$$

### **Over Voltage Protection (OVP)**

In some condition, the resistive divider may be unconnected, which will cause PWM signal to operate with maximum duty cycle and the output voltage is boosted higher and higher. The power MOSFET will be turned off immediately when the output voltage exceeds the OVP threshold level.

### **Input / Output Capacitors Selection**

The input capacitors are used to suppress the noise amplitude of the input voltage and provide a stable and clean DC input to the device. Because the ceramic capacitor has low ESR characteristic, so it is suitable for input capacitor use. It is recommended to use X5R or X7R MLCC capacitors in order to have better temperature performance and smaller capacitance tolerance. In order to suppress the output voltage ripple, the MLCC capacitor is also the best choice. The suggested value of input / output capacitors are 22μF.

### **Inductor Selection**

The recommended values of inductor are 4.7μH to 22μH. Small size and better efficiency are the major concerns for portable device. The inductor should have low core loss at 1.2MHz and low DCR for better efficiency. To avoid inductor saturation, the current rating should be considered.

### **Diode Selection**

Schottky diodes with low forward voltages are recommended for EA2208L. Ensure the diode current rating exceed the output current and the peak inductor current. The diode's reverse breakdown voltage should be larger than the output voltage.

### **PCB Layout Recommendations**

For EA2208L PCB layout considerations, please refer to the following suggestions in order to get good performance.

- ▶ High current path traces need to be widened.
- ▶ Place the input and output capacitors as close as possible to the device to reduce noise interference.
- ▶ The GND pin should be connected to a large area ground plane
- ▶ Keep the feedback path (from V<sub>OUT</sub> to FBK) away from the noise node (ex. SWITCH).

**Package Information**

SOT-23-6 Package

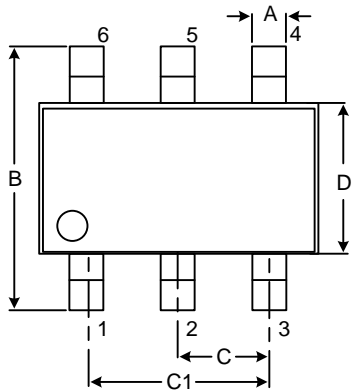

Top View

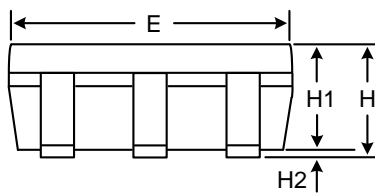

Side View

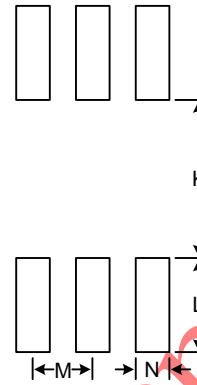

Recommended Layout Pattern

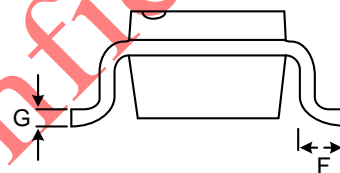

Front View

Unit: mm

Symbol	Dimension		Symbol	Dimension
	Min	Max		Typ
A	0.25	0.52	K	1.40
B	2.59	3.01	L	1.40
C	0.85	1.05	M	0.95
C1	1.70	2.10	N	0.65
D	1.40	1.80		
E	2.70	3.10		
F	0.30	0.62		
G	0.08	0.25		
H	0.89	1.35		
H1	0.89	1.20		
H2	0.00	0.15		



## X-ON Electronics

Largest Supplier of Electrical and Electronic Components

*Click to view similar products for [Isolated DC/DC Converters](#) category:*

*Click to view products by [Everanalog](#) manufacturer:*

Other Similar products are found below :

[PSL486-7LR](#) [Q48T30020-NBB0](#) [JAHW100Y1](#) [SPB05C-12](#) [SQ24S15033-PS0S](#) [CE-1003](#) [CE-1004](#) [MAU228](#) [J80-0041NL](#) [DFC15U48D15](#)  
[XGS-1205](#) [06322](#) [SPB05B-15](#) [L-DA20](#) [DCG40-5G](#) [XKS-2405](#) [DPA423R](#) [vi-m13-cw-03](#) [VI-L53-CV](#) [24IBX15-50-0ZG](#) [HZZ01204-G](#)  
[SPU02L-09](#) [SPU02M-09](#) [SPU02N-09](#) [QUINT4-BUFFER/24DC/40](#) [QUINT4-CAP/24DC/5/4KJ](#) [73-551-5039I](#) [DFC15U48D15G](#) [SEN-6471-](#)  
[1EM](#) [AHV2815DF/HBB](#) [MI-LC21-IX](#) [PAH-48/8.5-D48NB1-C](#) [BM3020-7A](#) [QRS2050P025R06](#) [QRS2050P025K00](#) [CM2320-9EG](#)  
[SKMW15F-05](#) [V300A28H400BF3](#) [TEN 15-1223](#) [TEQ 100-2418WIR](#) [TEQ 160-7218WIR](#) [R05C05TE05S-R](#) [HQA2W085W033V-N07-S](#)  
[AM1SS-2405SJZ](#) [AM2DS-1224SJZ](#) [AM2DS-2405DJZ](#) [AM10SBO-4824SNZ-B](#) [AM15E-2405S-NZ](#) [AM2DS-1212SJZ](#) [AM30SBO-](#)  
[4805SNZ-B](#)