

## General Description

The EA9104 is designed for portable RF and wireless applications with demanding performance and space requirements. The EA9104 performance is optimized for battery-powered systems to deliver ultra low noise and low quiescent current. Regulator ground current increases only slightly in dropout, further prolonging the battery life. The EA9104 also works with low-ESR ceramic capacitors, reducing the amount of board space necessary for power applications, critical in hand-held wireless devices. The EA9104 consumes less than 0.1uA in shutdown mode and has fast turn-on time less than 50us. The other features include ultra low dropout voltage, high output accuracy, current limiting protection and high ripple rejection ratio. The EA9104 is available in the 5-lead of SOT23-5 package.

## Features

- ▶ Ultra-Low-Noise for RF Application
- ▶ 2V to 5.5V Input Voltage Range
- ▶ Low Dropout: 210mV@300mA
- ▶ 300mA Output Current, 550mA Peak Current
- ▶ High PSRR: -70dB at 1KHz
- ▶ < 0.1uA Standby Current When Shutdown
- ▶ TTL-Logic-Controlled Shutdown Input
- ▶ Ultra-Fast Response in Line/Load transient
- ▶ Current Limiting and Thermal Shutdown Protection
- ▶ Quick Start-up (typically 50us)
- ▶ Available in SOT-23-5 Package

## Applications

- ▶ Portable Media Players/MP3 players
- ▶ Cellular and Smart Mobile Phone
- ▶ LCD TVs and Flat TVs
- ▶ Wireless System



## Pin Configurations

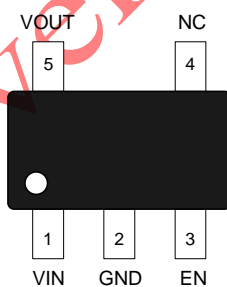

Fixed Output Voltage

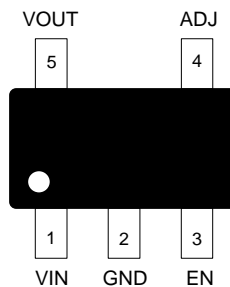

Adjustable Output Voltage

**Pin Description**

Pin Name	Function Description	Pin No.	
		Fixed VOUT	Adjustable VOUT
VIN	Power input voltage pin.	1	1
GND	Ground pin.	2	2
EN	Enable pin. There is an internal pull low 1MΩ resistor connected to GND.	3	3
NC	Not Connect.	4	--
ADJ	Adjustable pin.	--	4
VOUT	Output voltage pin.	5	5

**Function Block Diagram**

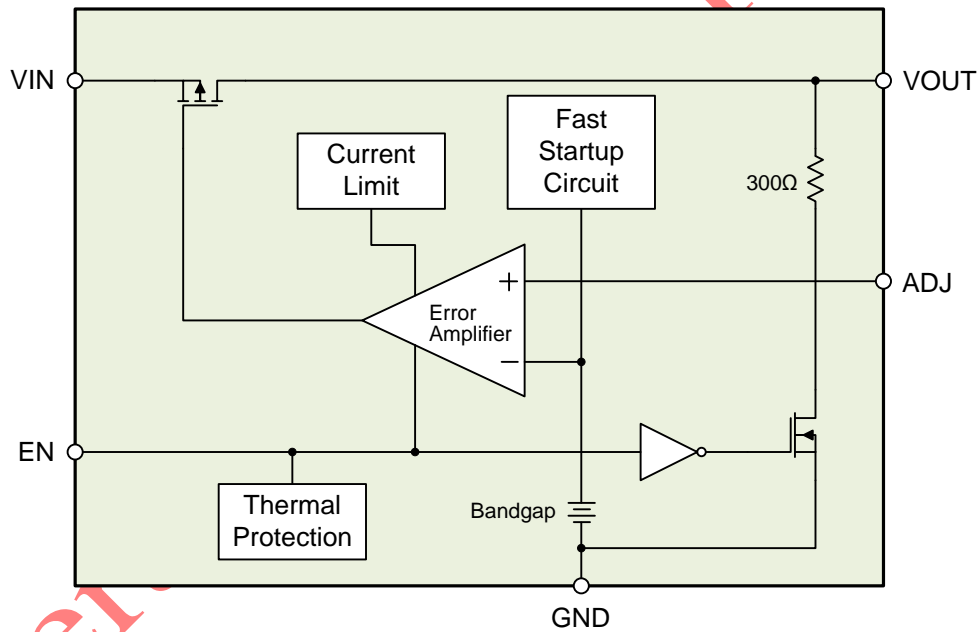

Figure 1. EA9104 internal function block diagram (Adjustable Output Voltage)

### Absolute Maximum Ratings

Parameter	Value
Input Supply Voltage ( $V_{IN}$ )	-0.3V to +6V
Lead Temperature (Soldering, 10 sec)	+260°C
Storage Temperature Range ( $T_S$ )	-65°C to +150°C
ESD Susceptibility (HBM)	2kV
ESD Susceptibility (MM)	200V

Note (1): Stresses beyond those listed under "Absolute Maximum Ratings" may cause permanent damage to the device. Exposure to "Absolute Maximum Ratings" conditions for extended periods may affect device reliability and lifetime.

### Package Thermal Characteristics

Parameter	Value
SOT-23-5 Thermal Resistance ( $\theta_{JC}$ )	125°C/W
SOT-23-5 Thermal Resistance ( $\theta_{JA}$ )	250°C/W
SOT-23-5 Power Dissipation at $T_A=25^\circ\text{C}$ ( $P_{Dmax}$ )	0.4W

Note (1):  $P_{Dmax}$  is calculated according to the formula:  $P_{Dmax}=(T_{JMAX}-T_A)/\theta_{JA}$ .

### Recommended Operating Conditions

Parameter	Value
Ambient Temperature Range ( $T_A$ )	-20°C to +85°C
Junction Temperature Range ( $T_J$ )	-40°C to +125°C

Everanalog Confidential

## Electrical Characteristics

$V_{IN} = V_{OUT} + 1V$ ,  $C_{IN} = C_{OUT} = 1\mu F$ ,  $T_A = 25^\circ C$ , unless otherwise noted

Parameter	Symbol	Test Conditions	Min	Typ	Max	Unit
Output Voltage Accuracy	$\Delta V_{OUT}$	$I_{OUT} = 1mA$	-2		2	%
Output Loading Current	$I_{LOAD}$	$V_{EN} = V_{IN}$ , $V_{IN} > 2.5V$		300		mA
Current Limit	$I_{LIM}$	$R_{LOAD} = 1\Omega$	450	550		mA
Adjustable Voltage Reference	$V_{FB}$		0.784	0.8	0.816	V
Quiescent Current	$I_Q$	$V_{EN} \geq 1.2V$ , $I_{OUT} = 0mA$		100	130	$\mu A$
Dropout Voltage	$V_{DROP}$	$I_{OUT} = 200mA$ , $V_{OUT} > 2.8V$		140	180	mV
		$I_{OUT} = 300mA$ , $V_{OUT} > 2.8V$		210	270	mV
Line Regulation	$\Delta V_{LINE}$	$V_{IN} = (V_{OUT} + 1V)$ to $5.5V$ , $I_{OUT} = 1mA$			0.3	%
Load Regulation	$\Delta LOAD$	$1mA < I_{OUT} < 300mA$			2	%
Standby Current	$I_{STBY}$	$V_{EN} = GND$ , Shutdown		0.1	1	$\mu A$
EN Input Bias Current	$I_{IBSD}$	$V_{EN} = 3.5V$	2	3.5	5	$\mu A$
EN Threshold Low Voltage	$V_{IL}$	$V_{IN} = 3V$ to $5.5V$ , Shutdown			0.4	V
EN Threshold High Voltage	$V_{IH}$	$V_{IN} = 3V$ to $5.5V$ , Start-up	1.2			V
Output Noise Voltage		10Hz to 100kHz, $I_{OUT} = 200mA$ , $C_{OUT} = 1\mu F$		100		$\mu VRMS$
Power Supply Rejection Rate $f = 100Hz$	PSRR	$C_{OUT} = 1\mu F$ , $I_{OUT} = 10mA$		-76		dB
Power Supply Rejection Rate $f = 10kHz$				-65		dB
Thermal Shutdown Threshold	$T_{SD}$			165		$^\circ C$

Note (1): MOSFET on-resistance specifications are guaranteed by correlation to wafer level measurements.

(2): Thermal shutdown specifications are guaranteed by correlation to the design and characteristics analysis.

**Application Circuit Diagram**

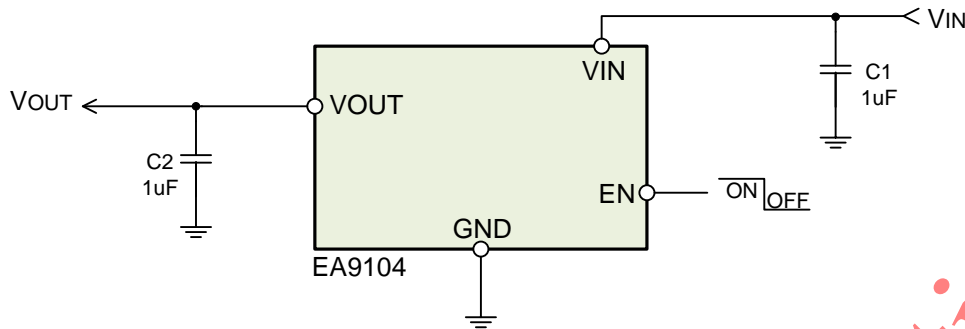

Figure 2. Typical application circuit diagram (Fixed output voltage)

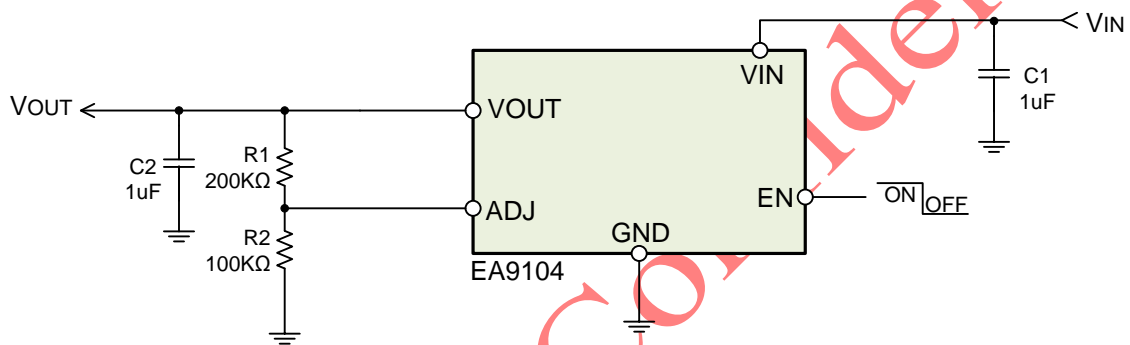

Figure 3. Typical application circuit diagram (Adjustable output voltage)

**Ordering Information**

Part Number	Package Type	Packing Information
EA9104VVT5R	SOT-23-5	Tape & Reel / 3000

Note (1):“VV”: Output voltage version code.  
 (2):“T5”: Package type code.  
 (3):“R”: Tape & Reel.

Output Voltage Version Code	Output Voltage
12	1.2V
15	1.5V
18	1.8V
25	2.5V
28	2.8V
30	3.0V
33	3.3V
36	3.6V
AD	Adjustable

### Typical Operating Characteristics

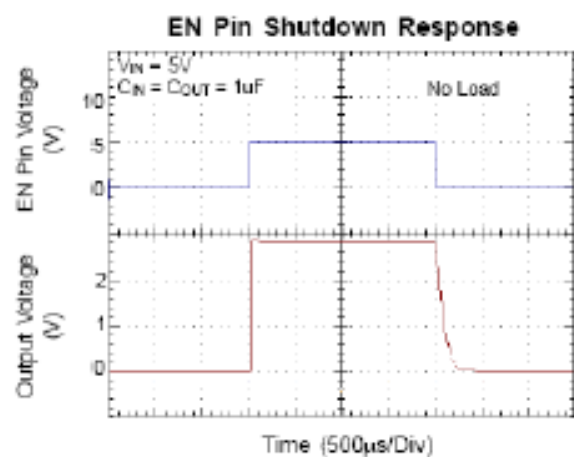
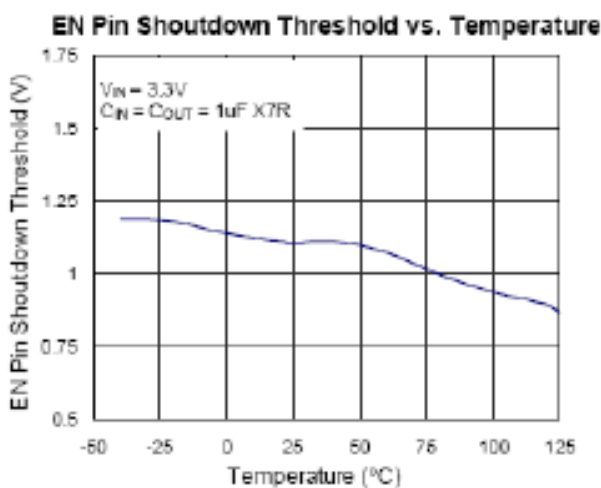
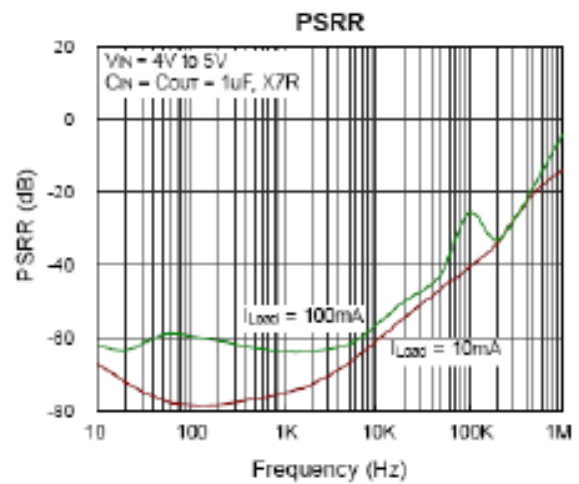
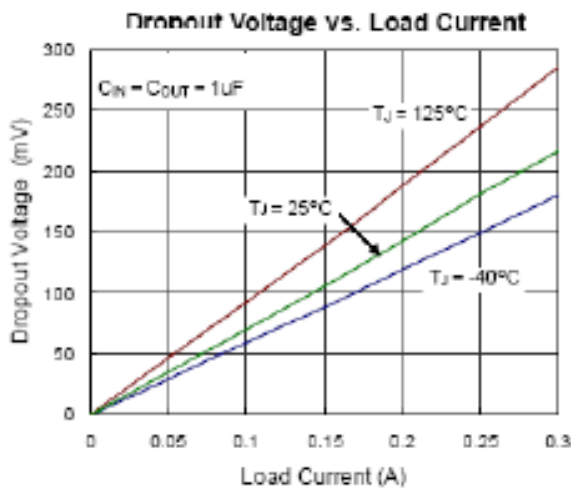
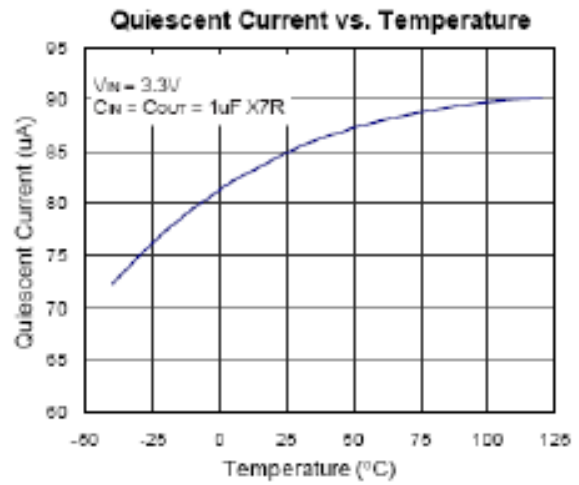
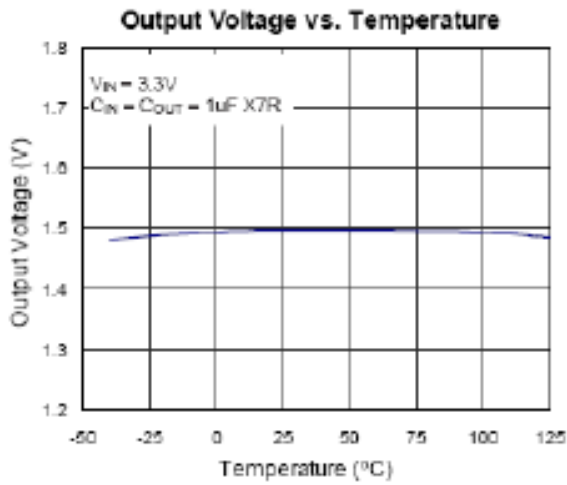

Typical Operating Characteristics

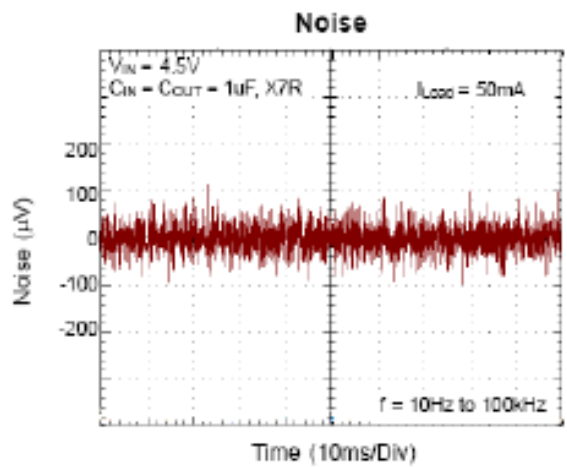
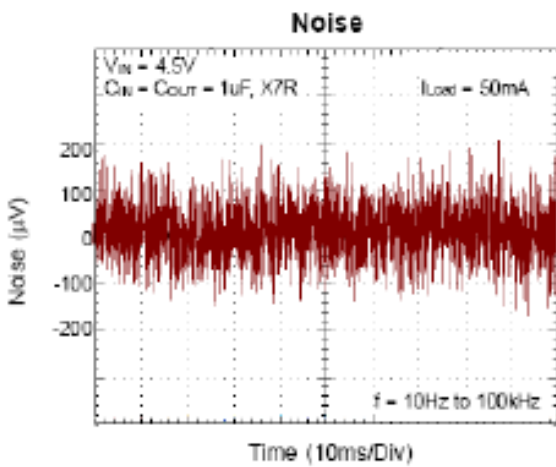
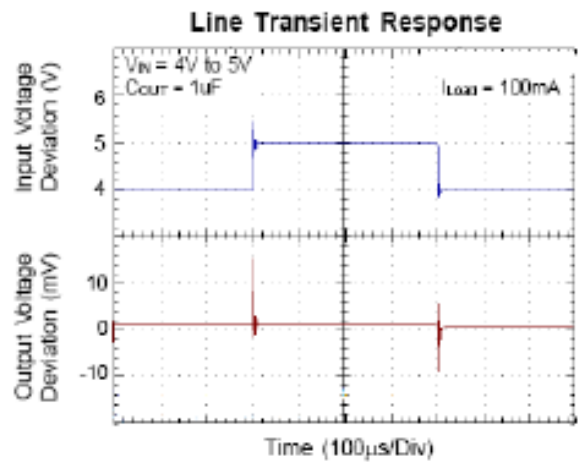
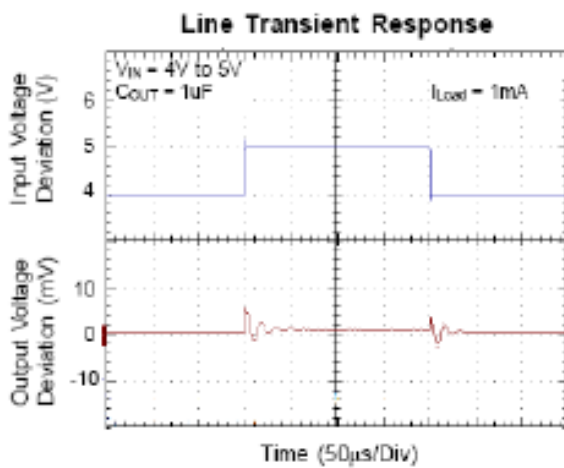
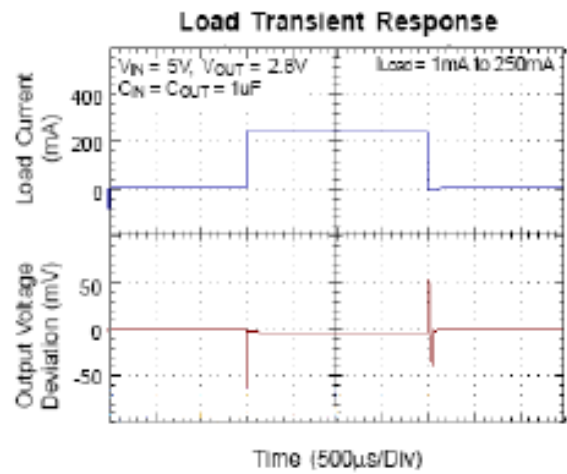
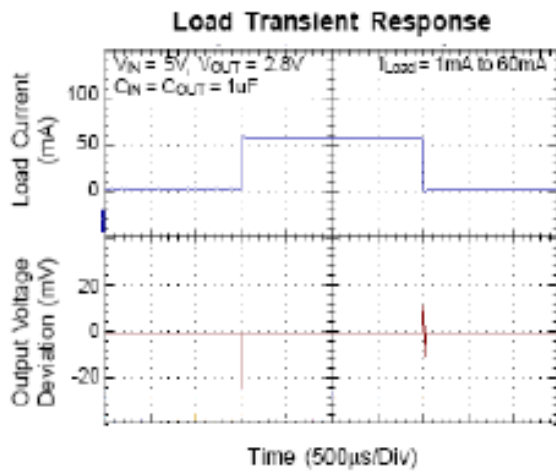

## **Application Information**

Like any low-dropout regulator, the external capacitors used with the EA9104 must be carefully selected for regulator stability and performance. Using a capacitor whose value is  $> 1\mu\text{F}$  on the EA9104 input and the amount of capacitance can be increased without limit. The input capacitor must be located a distance that less than 0.5 inch from the input pin of the device to a clean analog ground. Any good quality ceramic or tantalum can be used for this capacitor. The capacitor with larger value and lower ESR (equivalent series resistance) provides better PSRR and line transient response. The output capacitor must meet both requirements for minimum amount of capacitance and ESR in all LDOs application. The EA9104 is designed specifically to work with low ESR ceramic output capacitor in space-saving and performance consideration. Using a ceramic capacitor whose value is at least  $1\mu\text{F}$  with ESR is  $> 25\text{m}\Omega$  on the EA9104 output ensures stability. The EA9104 still works well with output capacitor of other types due to the wide stable ESR range. Output capacitor of larger capacitance can reduce noise and improve load transient response, stability and PSRR. The EA9104 features an LDO regulator enable/disable function. To assure the LDO regulator will switch on, the EN turn on control level must be greater than 1.2V. The LDO regulator will go into the shutdown mode when the voltage on the EN pin falls below 0.4V. The EA9104 have a quick-discharge function to protecting the system. If the enable function is not needed in a specific application, it may be tied to VIN to keep the LDO regulator in a continuously on state.

## **Thermal Considerations**

Thermal protection limits power dissipation in EA9104. When the operation junction temperature exceeds  $165^\circ\text{C}$ , the OTP circuit starts the thermal shutdown function turn the pass element off. The pass element turn on again after the junction temperature cools by  $30^\circ\text{C}$ . For continue operation, do not exceed absolute maximum operation junction temperature  $125^\circ\text{C}$ . The maximum power dissipation depends on the thermal resistance of IC package, PCB layout, the rate of surroundings airflow and temperature difference between junction to ambient. The maximum power dissipation can be calculated by following formula:

$$P_{D(\text{MAX})} = (T_{J(\text{MAX})} - T_A) / \theta_{JA}$$

Where  $T_{J(\text{MAX})}$  is the maximum operation junction temperature  $125^\circ\text{C}$ ,  $T_A$  is the ambient temperature and the  $\theta_{JA}$  is the junction to ambient thermal resistance. For recommended operating conditions specification of EA9104, the  $T_{J(\text{MAX})}$  is the maximum junction temperature of the die ( $125^\circ\text{C}$ ) and  $T_A$  is the maximum ambient temperature. The junction to ambient thermal resistance  $\theta_{JA}$  for SOT23-5 package is  $250^\circ\text{C}/\text{W}$ .



**Package Information**

**SOT-23-5 Package**

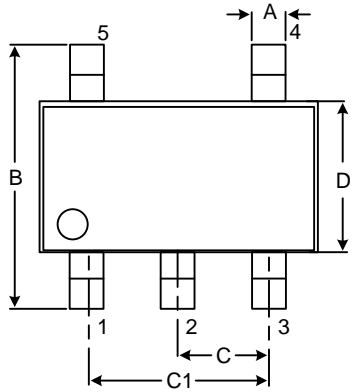

Top View

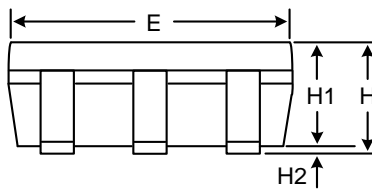

Side View

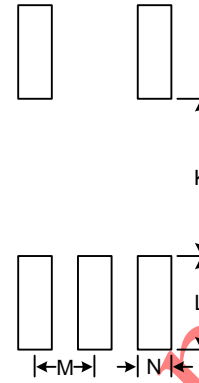

Recommended Layout Pattern

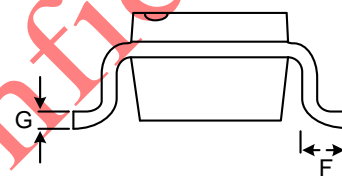

Front View

Unit: mm

Symbol	Dimension		Symbol	Dimension
	Min	Max		Typ
A	0.30	0.52	K	1.40
B	2.59	3.01	L	1.40
C	0.85	1.05	M	0.95
C1	1.70	2.10	N	0.65
D	1.40	1.80		
E	2.70	3.10		
F	0.30	0.61		
G	0.08	0.25		
H	0.89	1.35		
H1	0.89	1.20		
H2	0.00	0.15		

## X-ON Electronics

Largest Supplier of Electrical and Electronic Components

*Click to view similar products for [Linear Voltage Regulators](#) category:*

*Click to view products by [Everanalog](#) manufacturer:*

Other Similar products are found below :

[LV5684PVD-XH](#) [MCDTSA6-2R](#) [L7815ACV-DG](#) [714954EB](#) [ZMR500QFTA](#) [BA033LBSG2-TR](#) [LV5680P-E](#) [L79M05T-E](#) [L78LR05D-MA-E](#) [NCV317MBTG](#) [NTE7227](#) [MP2018GZD-33-P](#) [MP2018GZD-5-P](#) [LV5680NPVC-XH](#) [LT1054CN8](#) [ZTS6538SE](#) [UA78L09CLP](#) [UA78L09CLPR](#) [CAT6221-PPTD-GT3](#) [MC78M09CDTRK](#) [NCV51190MNTAG](#) [78M05](#) [HT7150-1](#) [UM1540DB-18](#) [XC6234H281VR-G](#) [WL2834CA-6/TR](#) [TPL730F33-5TR](#) [TLS850F1TA](#) [V50](#) [TPS549B22RVFR](#) [UM1540DB-33](#) [WL9200P3-50B](#) [WL9100P3-33B](#) [WL9005D4-33](#) [XC6219B152MR](#) [WL2855K33-3/TR](#) [PJ54BM33SE](#) [PJ9500M25SA](#) [MD7218E33PC1](#) [H7533-2PR](#) [SK7812AU](#) [SD1A30](#) [78L33](#) [TP78L33T3](#) [L78L33ACUTR](#) [SK6513ST3A-50](#) [SK6054D4-09](#) [SK6054D4-18](#) [SK6054D4-11](#) [SK6054D4-10](#) [LM79L12F](#)