



WE CATCH THE  
BEST TECH. FOREVER

# EVERBOUQUET INTERNATIONAL CO., LTD.

Address: 13F-3, No. 8, Lane 280, Sec. 6, Minchuan  
E. Rd., Nei-Hu 114, Taipei, Taiwan, R.O.C.  
TEL: 886-2-2633-1253 FAX: 886-2-2631-2881

PART NO.: MS-10-61202

FOR MESSRS.: \_\_\_\_\_

## CONTENTS

<i>NO.</i>	<i>ITEM</i>	<i>PAGE</i>
1.	COVER	1
2.	RECORD OF REVISION	2
3.	PRECAUTIONS FOR LCM	3~4
4.	OPTICAL DEFINITIONS	5
5.	TIMING CHARACTERISTICS	6~14
6.	QUALITY AND RELIABILITY	15~17
7.	DESIGNATION OF LOT MARK	18

ACCEPTED BY: \_\_\_\_\_

PROPOSED BY: \_\_\_\_\_

**RECORD OF REVISION**

<b>DATE</b>	<b>PAGE</b>	<b>SUMMARY</b>

### **3. Precautions for LCM**

#### **3-1 Precautions in handling LCD Modules (hereinafter LCM's)**

EVERBOUQUET INTERNATIONAL CO., LTD.'s LCM's have been assembled and accurately calibrated before delivery.

Please observe the following criteria when handling.

- A. Do not subject the module to excessive shock.
- B. Do not modify the tab on the metal holder.
- C. Do not tamper with the printed circuit board.
- D. Limit soldering of the printed circuit board to I/O terminals only.
- E. Do not touch the zebra strip nor modify its location.

#### **3-2 Static electricity warning:**

EVERBOUQUET's LCM uses CMOS LSI technology. Therefore, strict measures to avoid static electricity discharge are followed through all processes from manufacturing through shipping. When handling a LCM, take sufficient care to prevent static electricity discharge as you would any CMOS IC.

- A. Do not take the LCM from its anti-static bag until it's to be assembled. LCM's are individually packaged in bags specially treated to resist static electricity. When storing, keep the LCM packed in the original bags, or store them in a container processed to be resistant to static electricity, or in an electric conductive container.
- B. Always use a ground strap when handling a LCM.  
Always use a ground strap while working with the module, from the time it is taken out of the anti-static bag until it is assembled. When it is necessary to transfer the LCM, once it has been taken out of the bag, always place it in an electric conductive container. Avoid wearing clothes made of chemical fibers, the use of cotton or conductive treated fiber clothing is recommended.
- C. Use a no-leak iron for soldering the LCM.  
The soldering iron to be used for soldering the I/O terminals to the LCM are to be insulated or grounded at the iron tip.
- D. Always ground electrical apparatuses required for assembly.  
Electrical apparatuses required to assemble the LCM into a product, i.e. electrical screw drivers, are to be first grounded to avoid transmitting spike noises from the motor.
- E. Assure that the work bench is properly grounded.
- F. Peel off the LCM protective films slowly.  
The module is attached with a film to protect the display surface from contamination, damage, adhesion of flux, etc. Peeling off this film abruptly could case static electricity to be generated, so peel the tape slowly.
- G. Pay attention to the humidity in the work area.  
50~60% RH is recommended.

### ***3-3 Precautions for the soldering of an LCM***

The following procedures should be followed when soldering the LCM:

- A. Solder only to the I/O terminal.
- B. Use a no leakage soldering iron and pay particular attention to the following:

(1) Conditions for soldering I/O terminals

Temperature at iron tip: 280°C + 10°C

Soldering time: 3-4 sec/terminal

Type of solder : Eutectic solder (rosin flux filled)

Note: Avoid using flux, because it could penetrate the module and the module may get contaminated during cleaning. Peel off protective film after soldering of the I/O terminals is finished. By following this procedure, the surface contamination, caused by the dispersion of flux while soldering, can be avoided.

(2) Removing the wiring

When a lead wire or a connector to the I/O terminal of the module is to be removed, remove it only after the solder at the connection has sufficiently melted since the I/O terminal is a through hole. If it is forcefully removed, it could cause the terminal to break or peel. The recommended procedure is to use a suction-type solder remover. Caution, do not reheat the I/O terminal more than 3 times.

### ***3-4. Long-term storage***

If the correct method of storage is not followed, deterioration of the display material polarizer and oxidation of the I/O terminal plating may make the soldering process difficult. Please comply with the following procedure.

- A. Store in the shipping container.
- B. If the shipping container is not available, place in anti-static bags and seal the opening
- C. Store the modules where they are not subjected to direct sunlight or a fluorescent lamp.
- D. Store in a temperature range of 0°C~35°C with low relative humidity.

### ***3-5. Precautions in use of LCD modules***

- A. Do not give any external shock.
- B. Do not wipe the surface with hard materials.
- C. Do not apply excessive force on the surface.
- D. Do not expose to direct sunlight or fluorescent light for a long time.
- E. Avoid storage in high temperature and high humidity.
- F. When storage for a long time at 40°C or higher is required, R/H shall be less than 60%.
- G. Liquid in LCD is hazardous substance. Must not lick, swallow when the liquid is attached to your hands, skin, clothes etc. Wash it out thoroughly.

## 4. Optical definitions

### 4.1 Definition of angle $\Theta$ and $\Phi$

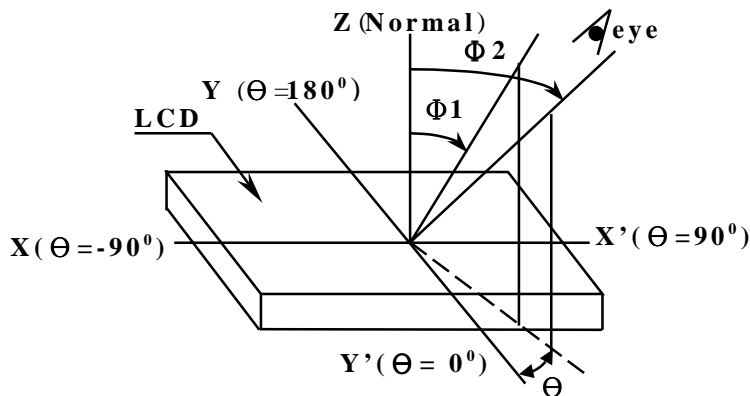

### POSITIVE TYPE

### 4.3 Definition of contrast "K"

$$K = \frac{\text{brightness of non-selected segment (B2)}}{\text{Brightness of selected segment (B1)}}$$

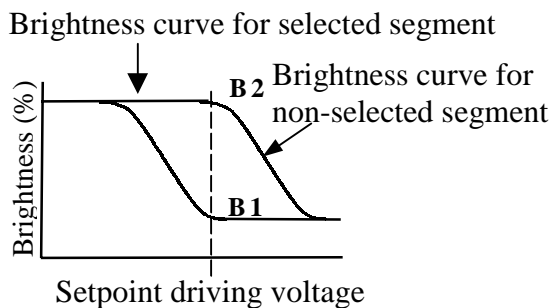

### NEGATIVE TYPE

### 4.5 Definition of contrast "K"

$$K = \frac{\text{Brightness of selected segment (B1)}}{\text{Brightness of non-selected segment (B2)}}$$

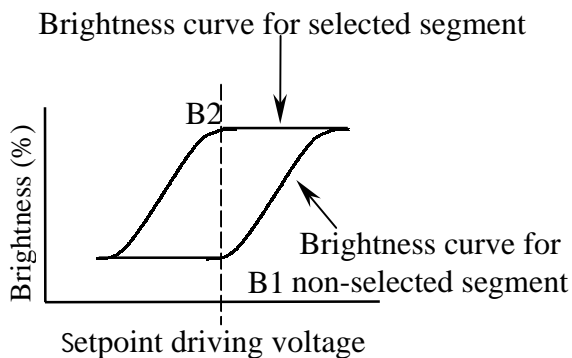

### 4.2 Definition of viewing angle

### $\Phi 1$ and $\Phi 2$

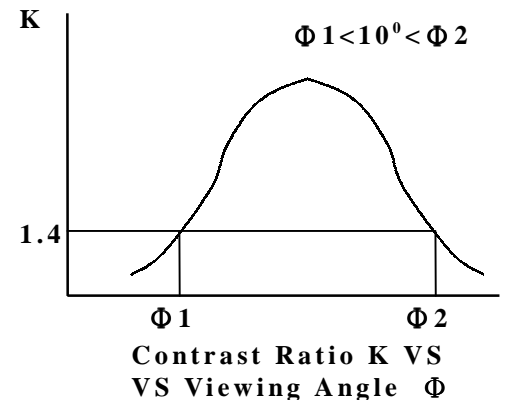

### POSITIVE TYPE

### 4.4 Definition of optical response

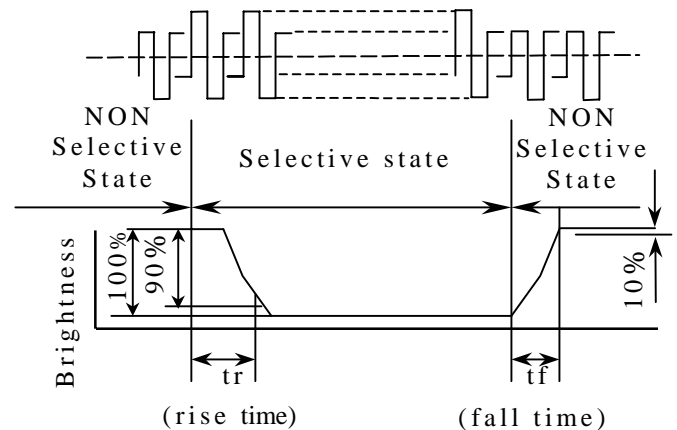

### NEGATIVE TYPE

### 4.6 Definition of optical response

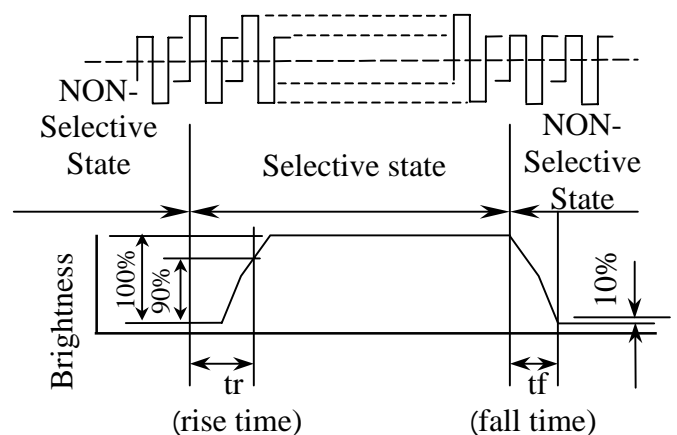

## 5. Timing Characteristics

### 5.1 Write operation

Item	Symbol	Min.	Typ.	Max.	Unit
Enable cycle time	t <sub>CYCL</sub>	1.0	—	—	μs
Enable high level width	P <sub>WEH</sub>	450	—	—	ns
Enable low level width	P <sub>WEL</sub>	450	—	—	ns
Enable rise time	t <sub>r</sub>	—	—	25	ns
Enable fall time	t <sub>f</sub>	—	—	25	ns
Address setup time	t <sub>AS</sub>	140	—	—	ns
Address hold time	t <sub>AH</sub>	10	—	—	ns
Data setup time	t <sub>DSW</sub>	200	—	—	ns
Data delay time	t <sub>DDR</sub>	—	—	320	ns
Data hold time (write)	t <sub>DHW</sub>	10	—	—	ns
Data hold time (read)	t <sub>DHR</sub>	20	—	—	ns

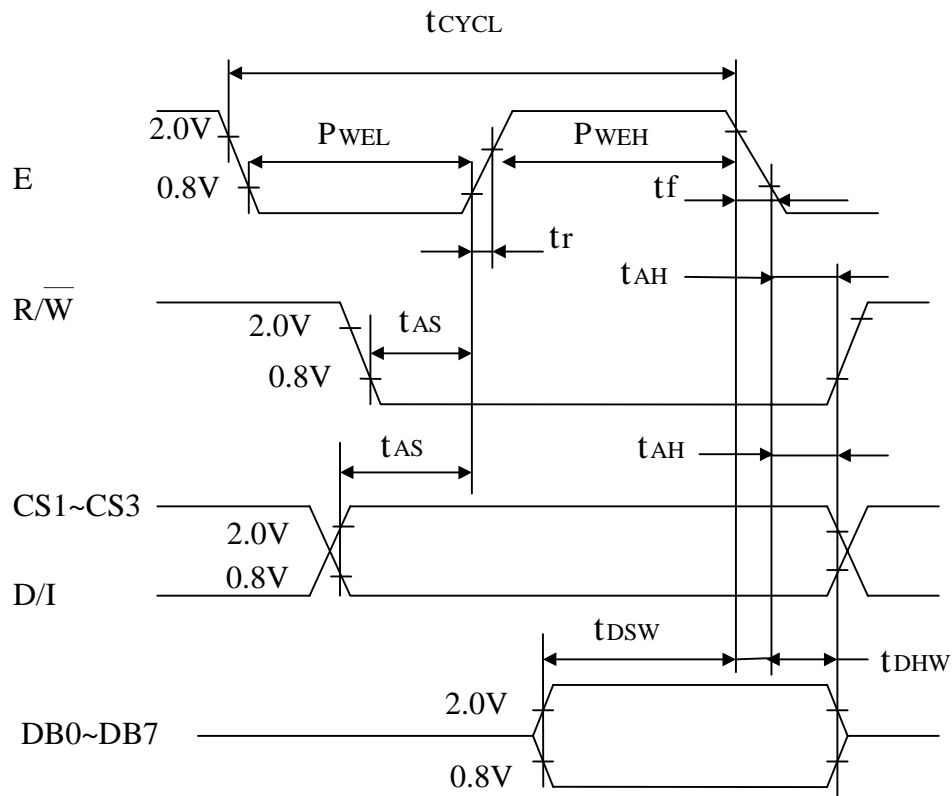

Figure 1 CPU Write Timing

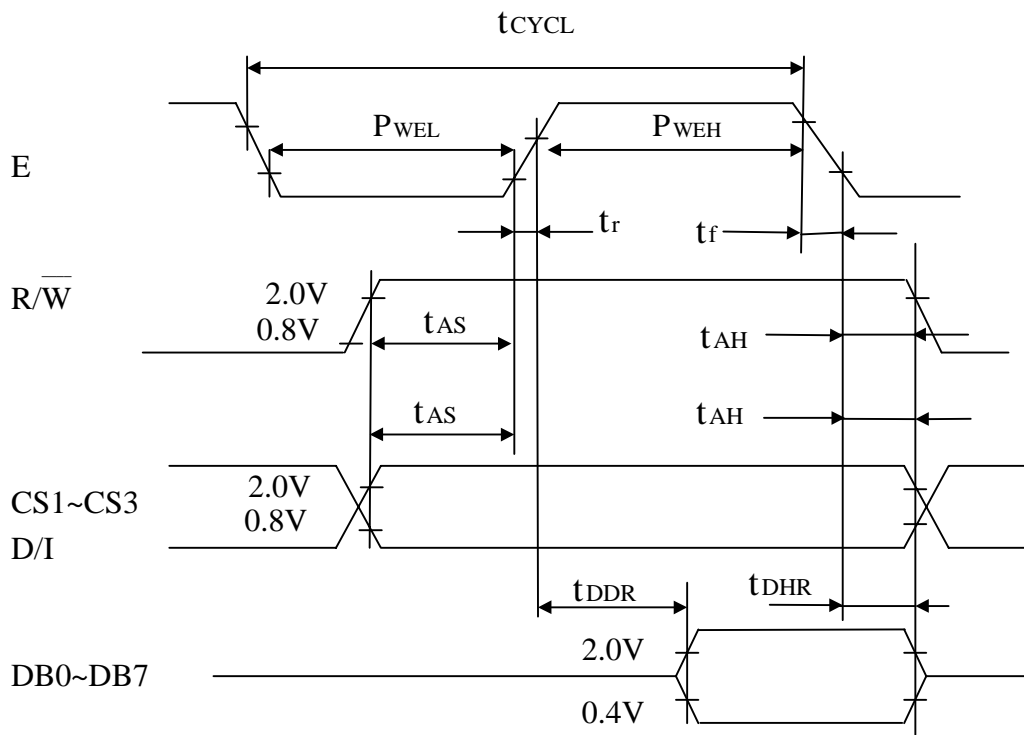
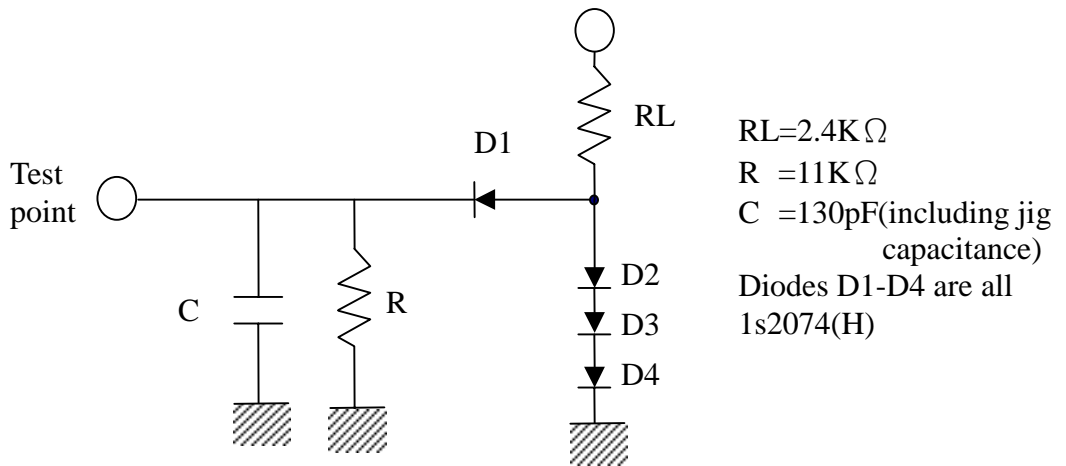

Figure 2 CPU Read Timing



## ■ *Display Control Instructions*

### ● *Outline*

Table 2 shows the instructions. Read/Write (R/W) signal. Data / Instruction (D/I) signal and data bus signal (DB0 to DB7) are also called instructions because the internal operation depends on the signals from MPU.

These explanations are detailed from the following page. Generally there are following three kinds of instructions.

- (1) Instruction to give addresses in the internal RAM
- (2) Instruction to transfer data from/to the internal RAM
- (3) Other instructions

In general use, the instruction (2) are used most frequently. But, since Y address of the internal RAM is increased by 1 automatically after writing (reading) data, the program can be lessened. During the execution of an instruction, the system cannot accept other instructions than Status Read instruction. Send instructions from MPU after making sure if the busy flag is "0", which is the proof an instruction is not being executed.



Table 2. Instructions

Instructions	Code										Functions	
	R/W	D/I	DB7	DB6	DB5	DB4	DB3	DB2	DB1	DB0		
1. Display ON/OFF	0	0	0	0	1	1	1	1	1	I/O	Controls the ON/OFF of display. RAM data and internal status are not affected. 1:ON, 0:OFF	
2. Display start line	0	0	0	0	Display start line (0~63)							Specifies a RAM line displayed at the top of the screen.
3. Set page (X address)	0	0	1	0	1	1	1	1	Page (0~7)		Sets the page (X address) of RAM at the page (X address) register.	
4. Set Address	0	0	0	1	Y address (0~63)							Sets the Y address at the Y address counter.
5. Status Read	1	0	B U S Y	0	ON / OFF	R E S E T	0	0	0	0	. Reads the status. RESET 1:reset 0:normal ON/OFF 1:display OFF 0:display ON Busy 1:on the internal operation 0:Ready	
6. Write display data	0	1	Write data									Writes data DB0 (LSB) to DB7 (MSB) on the data bus into display RAM. Has access to the address of the display RAM specified in advance. After the access. Y address is increased by 1.
7. Read display data	1	1	Read Data									Reads data DBO (LSB) to DB7 (MSB) from the display RAM to the data bus.

Note 1) busy time varies with the frequency (f<sub>CLK</sub>) of φ<sub>1</sub> and φ<sub>2</sub>.  
 $(1/f_{CLK} \cong T_{BUSY} \cong 3/f_{CLK})$

## Detailed Explanation

### (1) Display ON/OFF

	R/ $\overline{W}$	D/I	DB7	DB6	DB5	DB4	DB3	DB2	DB1	DB0
Code	0	0	0	0	1	1	1	1	1	D

-high-order-bit

-low-order-bit-

The display data appears when D is 1 and disappears when D is 0. Though the data is not on the screen width D=0. It remains in the display data RAM. There fore, you can make appear by changing D=0 into D=1.

### (2) Display start line

	R/ $\overline{W}$	D/I	DB7	DB6	DB5	DB4	DB3	DB2	DB1	DB0
Code	0	0	1	1	A	A	A	A	A	A

-high-order-bit

-low-order-bit-

Z address AAAAAA (binary) of the display data RAM is set at the display start line register and displayed at the top of the screen. Fig. 7 are the examples of display duty is 1/64 or more (ex.1/32, 1/24 etc.), the data of total line number of LCD screen, from the line specified by display start line instruction, is displayed.

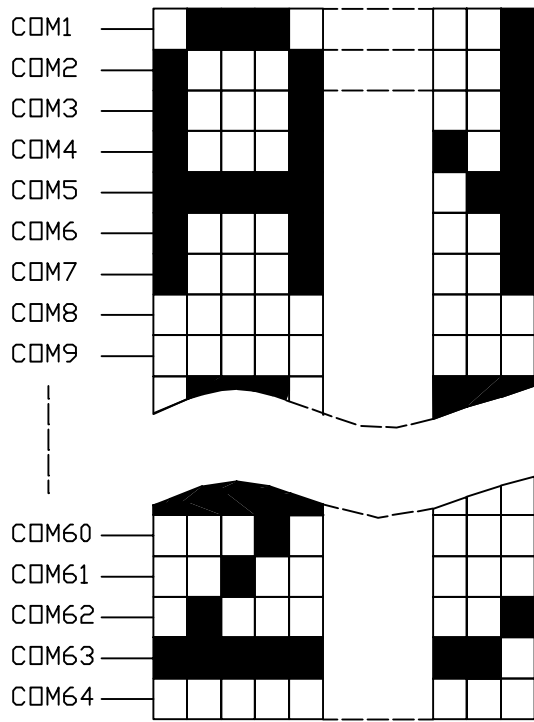

Start line=0

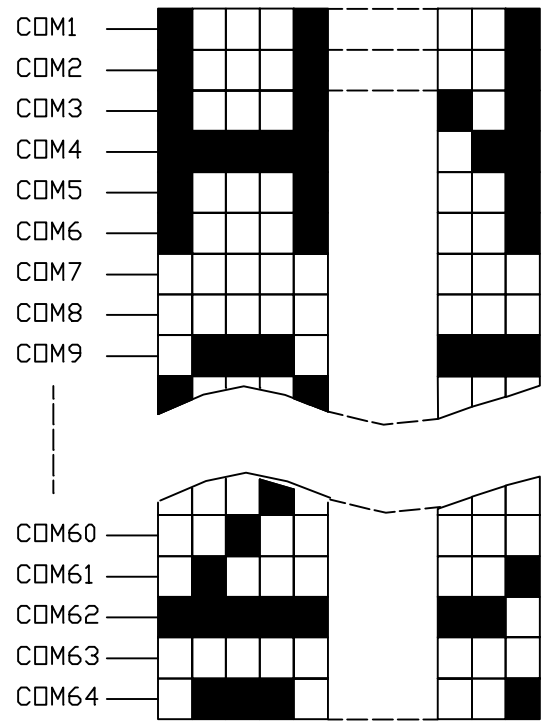

Start line=1

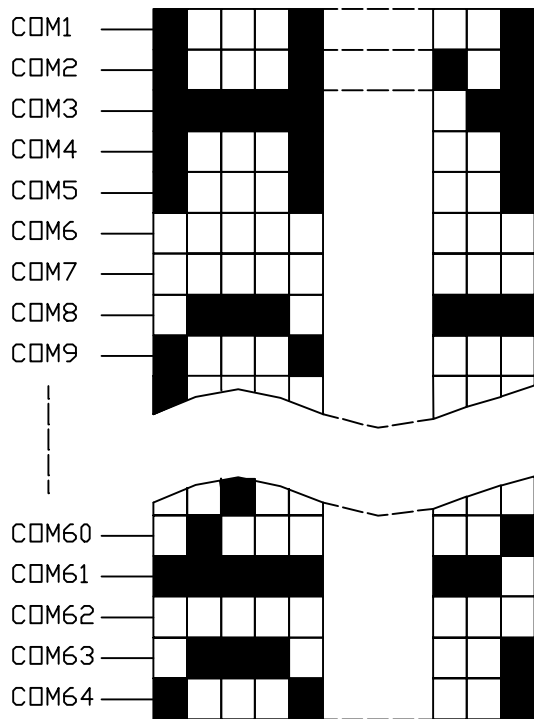

Start line=2

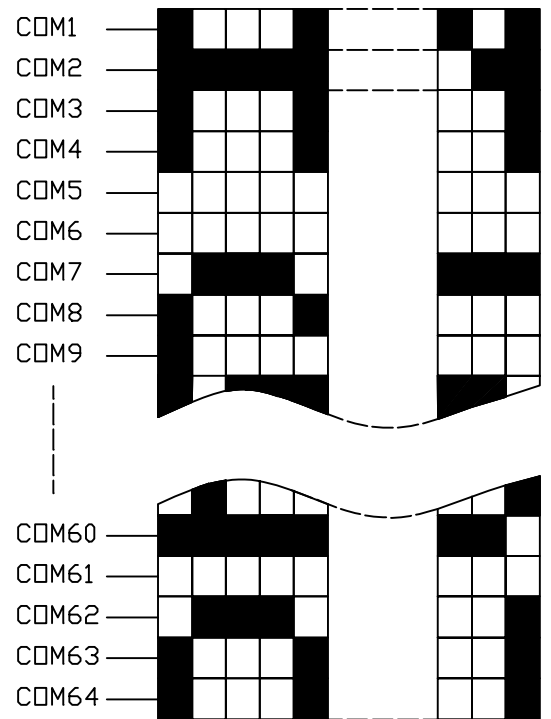

Start line=3

Fig.7 Relation Between Start Line and Display

(3) Set page (x address)

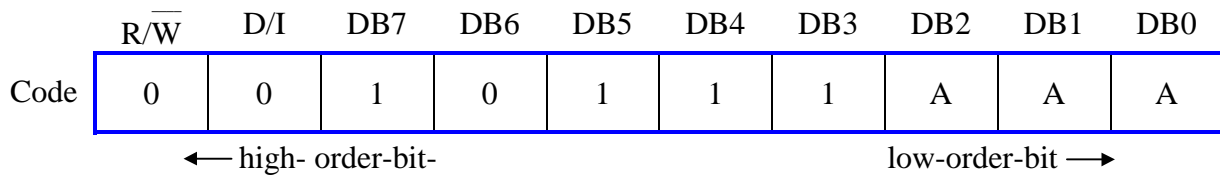

X address AAA (binary) of the display data RAM is set at the X address register. After that, writing or reading to or from MPU is executed in this specified page until the next page is set.

(4) Set Y address

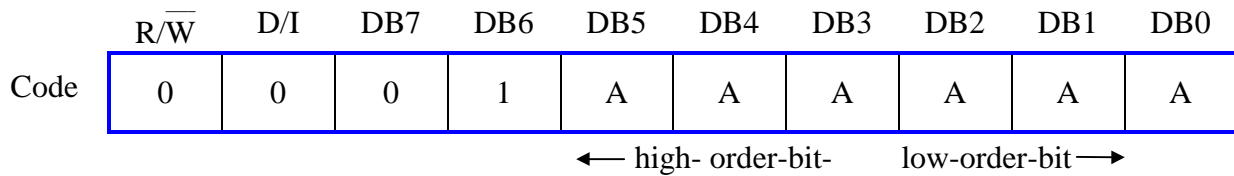

Y address AAAAAA (binary) of the display data RAM is set at the Y address counter.. After that, Y address counter is increased by 1 every time the data is written or read to or from MPU.

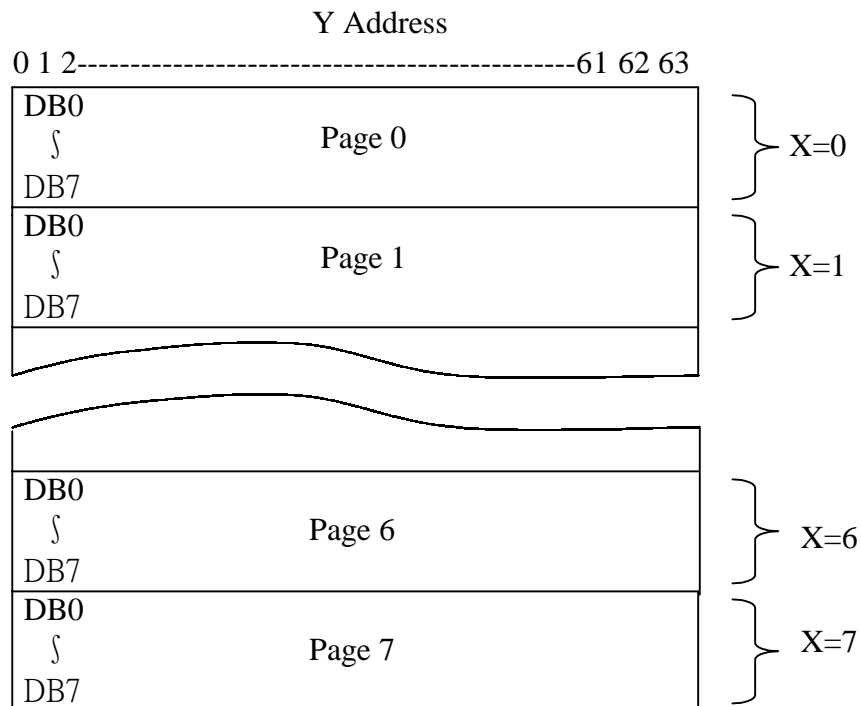

Fig.8 Address configuration of Display Data RAM

(5) Status Read

	R/ $\overline{W}$	D/I	DB7	DB6	DB5	DB4	DB3	DB2	DB1	DB0
Code	1	0	BUSY	0	ON/ OFF	RESET	0	0	0	0

← high-order-bit- low-order-bit →

**BUSY:** When BUSY is 1, the LS1 is in internal operation.

No instructions are accepted while BUSY is 1, so you should make sure that BUSY is 0 before writing the next instruction.

**ON/OFF:** This bit shows the liquid crystal display conditions –ON conditions or OFF condition.

When ON/OFF is 1, the display is in OFF condition.

When ON/OFF is 0, the display is in ON condition.

**RESET:** RESET=1 Shows that the system is being initialized. In this condition, any instructions except status read instruction cannot be accepted.

RESET=0 shows that initializing has finished and the system is in the usual operation.

(6) Write display data

	R/ $\overline{W}$	D/I	DB7	DB6	DB5	DB4	DB3	DB2	DB1	DB0
Code	0	1	D	D	D	D	D	D	D	D

← high-order-bit low-order-bit →

Write 8-bit data DDDDDDDD (binary) into the display data RAM. Then Y address is increased by 1 automatically.

(7) Read display data

	R/ $\overline{W}$	D/I	DB7	DB6	DB5	DB4	DB3	DB2	DB1	DB0
Code	1	1	D	D	D	D	D	D	D	D

← high-order-bit- low-order-bit →

Read out 8-bit data DDDDDDDD (binary) from the display data RAM. Then Y address is increased by 1 automatically.

One dummy read is necessary soon after the address setting. For details, refer to the explanation of output register in “FUNCTION OF EACH BLOCK”

## 6. Quality and reliability

### 6-1 Test condition

test should be conducted under the following conditions:

Ambient temperature:  $25 \pm 5^{\circ}\text{C}$

Humidity :  $60 \pm 20\% \text{RH}$

### 6-2 Sampling plan

Sampling method shall be in accordance with MIL-STD-105D, inspection level II, normal inspection, and single sampling plan tables for normal tightened, and reduced inspection.

### 6-3 Acceptable quality level

A major defect is a defect that could result in failure or materially reduce that the usability of the unit of product for its intended purpose.

A minor defect is one that does not materially reduce the usability of the unit of product for its intended purpose or is a departure from established standards having no significant bearing on the effective use or operation of the unit.

### 6-4 Appearance

Appearance test is to be conducted by human eyes at approximately 30 cm distance from LCD module under the single fluorescent light.

The inspection area of LCD panel shall be within the range of following limits.

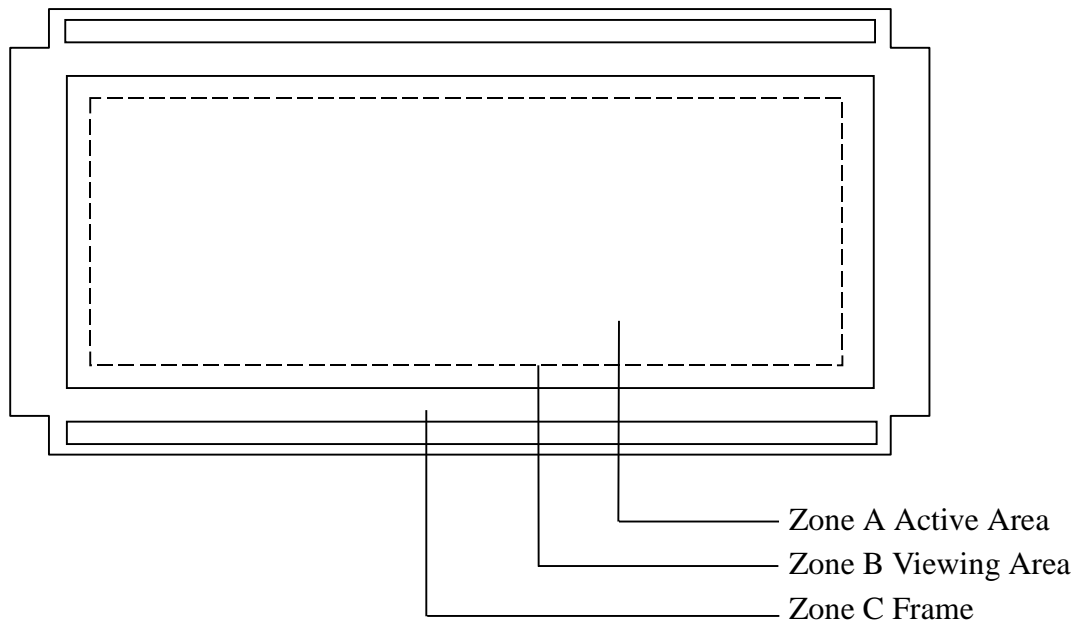

### 6-5 Inspection quality criteria

<i>ITME</i>	<i>DESCRIPTION OF DEFECTS</i>			<i>Class of defects</i>	<i>Acceptable level (%)</i>	
FUNCTION	Short circuit or Pattern cut			Major	0.65	
DIMENSION	Deviation from drawings			Major	2.5	
BLACK SPOTS	Ave. dia. D	area A	area B	Minor	2.5	
	$D \leq 0.2$	disregard				
	$0.2 < D \leq 0.3$	3	4			
	$0.3 < D \leq 0.4$	2	3			
	$0.4 < D$	0	1			
BLACK LINES	Width W, Length L		A	B	Minor	2.5
	$W \leq 0.03$		disregard			
	$0.03 < W \leq 0.05$		3	4		
	$0.05 < W \leq 0.07, L \leq 3.0$		1	1		
	See line criteria					
BUBBLES IN POLARIZER	Average diameter D $0.2 < D < 0.5$ mm for N = 4 D > 0.5 for N=1			Minor	2.5	
COLOR UNIFORMITY	Rainbow color or Newton ring.			Minor	2.5	
GLASS SCRATCHES	Obvious visible damage.			Minor	2.5	
VIEWING ANGLE	See note 2			Minor	2.5	
CONTRAST RATIO	See note 3			Minor	2.5	
RESPONSE TIME	See note 1			Minor	2.5	



## 6-6 Reliability

*The LCD module should have no failure in the following reliability test.*

<i>TEST ITEM</i>	<i>TEST CONDITIONS</i>	<i>NOTE</i>
HIGH TEMPERATURE STORAGE	60°C , 200 hr.	NOTE
LOW TEMPERATURE STORAGE	-10°C , 200 hr.	NOTE
HUMIDITY STORAGE	60°C , 90%RH , 96hr.	NOTE
HIGH TEMPERATURE OPERATION	40°C, typical operating conditions, 200hr.	NOTE
TEMPERATURE CYCLING	-10°C~70°C 10min. between each step temp. 50min. at each step temp. 5 cycles.	NOTE
MECHANICAL VIBRATION	10~55Hz sweep, 3G. amp1,=10mm(max) XYZ for 10min. each.	NOTE

NOTE 1: The module should not have condensation of water on the module.

NOTE 2: The module should be inspected after 1 hour storage in normal conditions (15~35°C, 45~65%RH).

### DEFINITIONS OF LIFE END POINT:

- (1) Current drain should be smaller than the specified value.
- (2) Function of the module should be maintained.
- (3) Appearance and display quality should not have distinguished degradation.
- (4) Contrast ratio should be larger than 50% of initial value.

## 7. Designation of lot mark

### 7-1 Lot mark

Lot mark is consisted of 4 digit number.

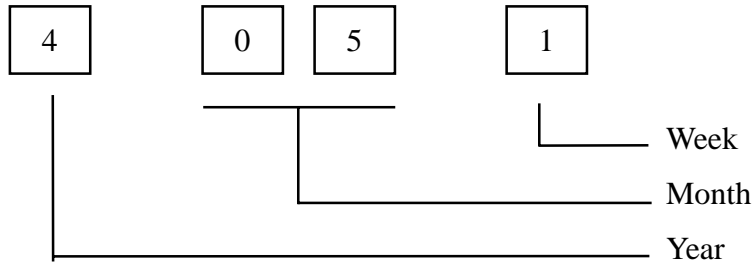

YEAR	FIGURE IN LOT MARK
1989	9
1990	0
1991	1
1992	2
1993	3
1994	4

MONTH	FIGURE IN LOT MARK	MONTH	FIGURE IN LOT MARK
Jan.	01	July	07
Feb.	02	Aug.	08
Mar.	03	Sept.	09
Apr.	04	Oct.	10
May.	05	Nov.	11
June	06	Dec.	12

WEEK (DAY IN CALENDAR)	FIGURE IN LOT MARK
1~7	1
8~14	2
15~21	3
22~28	4
29~31	5

## **X-ON Electronics**

Largest Supplier of Electrical and Electronic Components

*Click to view similar products for [everbouquet](#) manufacturer:*

Other Similar products are found below :

[Everbouquet](#)