

Low Power Mono Audio CODEC

FEATURES

System

- High performance and low power multi-bit delta-sigma audio ADC and DAC
- I²S/PCM master or slave serial data port
- 256/384Fs, USB 12/24 MHz and other non standard audio system clocks
- I²C interface

ADC

- 24-bit, 8 to 96 kHz sampling frequency
- 100 dB signal to noise ratio, -93 dB THD+N
- One pair of analog input with differential input option
- Low noise pre-amplifier
- Noise reduction filters
- Auto level control (ALC) and noise gate
- Support analog and digital microphone

DAC

- 24-bit, 8 to 96 kHz sampling frequency
- 110 dB signal to noise ratio, -80 dB THD+N
- One pair of analog output with headphone driver and differential output option
- Dynamic range compression
- Pop and click noise suppression

Low Power

- 1.8V to 3.3V operation
- 14 mW playback and record
- Low standby current

APPLICATIONS

- Automotive
- Phone
- Toy
- 2-way radio
- Dash cam
- IP Camera
- DVR, NVR
- Surveillance

ORDERING INFORMATION

ES8311 -40°C ~ +105°C
QFN-20

1. BLOCK DIAGRAM

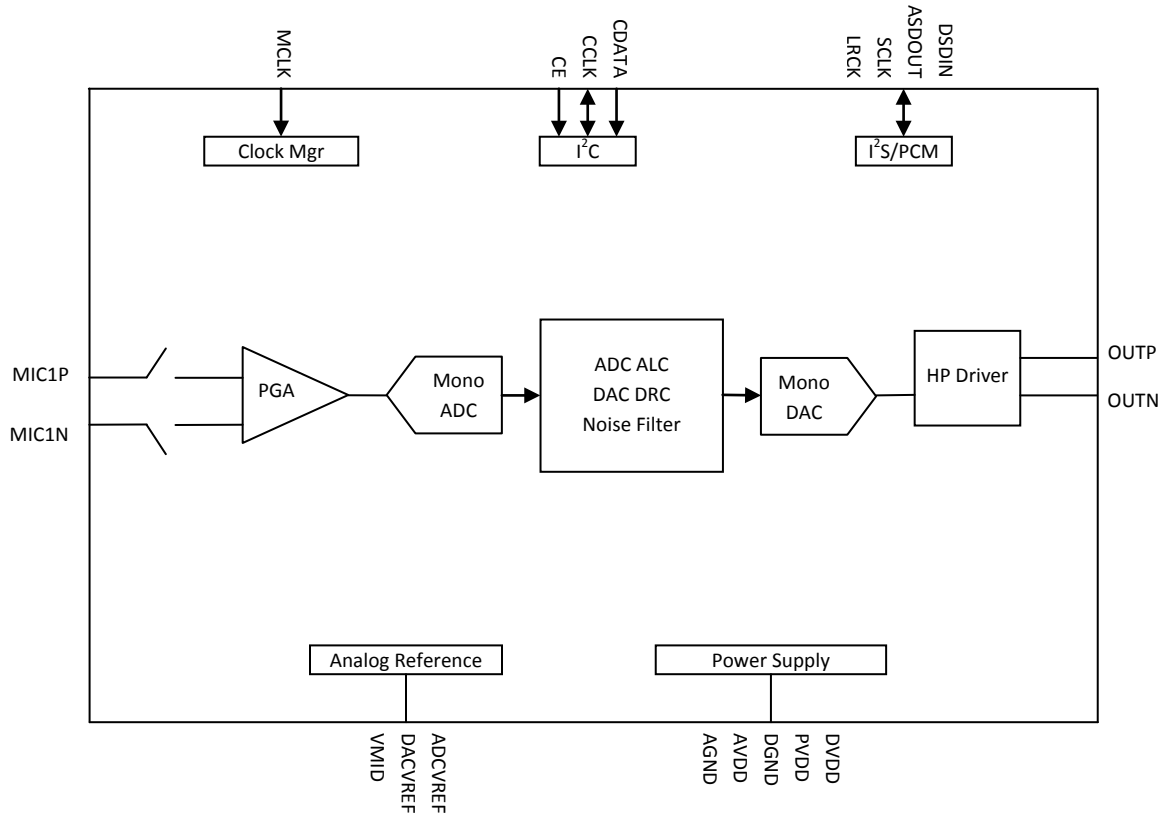

2. PIN OUT AND DESCRIPTION

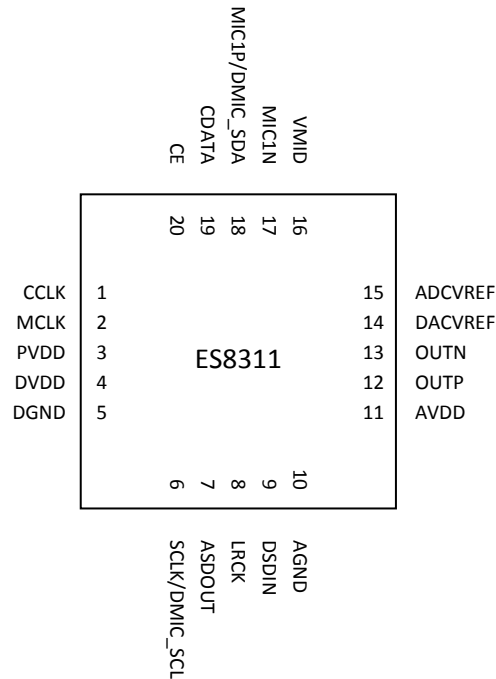

Pin Name	Pin number	Input or Output	Pin Description
CCLK, CDATA, CE	1, 19, 20	I, I/O, I	I ² C clock, data, address
MCLK	2	I	Master clock
SCLK/DMIC_SCL	6	I/O	Serial data bit clock/DMIC bit clock
LRCK	8	I/O	Serial data left and right channel frame clock
ASDOUT	7	O	ADC serial data output
DSDIN	9	I	DAC serial data input
MIC1P/DMIC_SDA MIC1N	18 17	I	Mic input
OUTP, OUTN	12, 13	O	Differential analog output
PVDD	3	Analog	Power supply for the digital input and output
DVDD, DGND	4, 5	Analog	Digital power supply
AVDD, AGND	11, 10	Analog	Analog power supply
VMID	16	Analog	Filtering capacitor connection
ADCVREF, DACVREF	15, 14	Analog	Filtering capacitor connection

3. TYPICAL APPLICATION CIRCUIT

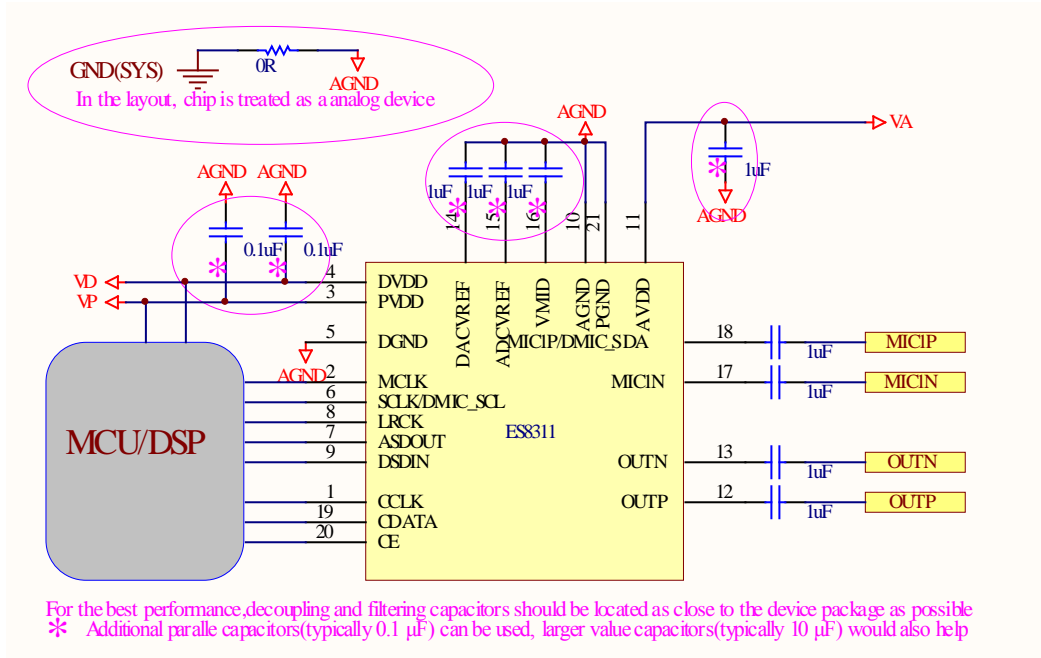

4. CLOCK MODES AND SAMPLING FREQUENCIES

The device supports standard audio clocks (64Fs, 128Fs, 256Fs, 384Fs, 512Fs, etc), USB clocks (12/24 MHz), and some common non standard audio clocks (16 MHz, 25 MHz, 26 MHz, etc).

According to the serial audio data sampling frequency (F_s), the device can work in two speed modes: single speed mode or double speed mode. In single speed mode, F_s normally ranges from 8 kHz to 48 kHz, and in double speed mode, F_s normally range from 64 kHz to 96 kHz.

The device can work either in master clock mode or slave clock mode. In slave mode, LRCK and SCLK are supplied externally, and LRCK and SCLK must be synchronously derived from the system clock with specific rates. In master mode, LRCK and SCLK are derived internally from device master clock.

5. MICRO-CONTROLLER CONFIGURATION INTERFACE

The device supports standard I²C micro-controller configuration interface. External micro-controller can completely configure the device through writing to internal configuration registers.

I²C interface is a bi-directional serial bus that uses a serial data line (CDATA) and a serial clock line (CCLK) for data transfer. The timing diagram for data transfer of this interface is given in Figure 1a and Figure 1b. Data are transmitted synchronously to CCLK clock on the CDATA line on a byte-by-byte basis. Each bit in a byte is sampled during CCLK high with MSB bit being transmitted firstly. Each transferred byte is followed by an acknowledge bit from receiver to pull the CDATA low. The transfer rate of this interface can be up to 400 kbps.

A master controller initiates the transmission by sending a “start” signal, which is defined as a high-to-low transition at CDATA while CCLK is high. The first byte transferred is the slave address. It is a seven-bit chip address followed by a RW bit. The chip address must be 0011 00x, where x equals CE. The RW bit indicates the slave data transfer direction. Once an acknowledge bit is received, the data transfer starts to proceed on a byte-by-byte basis in the direction specified by the RW bit. The master can terminate the communication by generating a “stop” signal, which is defined as a low-to-high transition at CDATA while CCLK is high.

In I²C interface mode, the registers can be written and read. The formats of “write” and “read” instructions are shown in Table 1 and Table 2. Please note that, to read data from a register, you must set R/W bit to 0 to access the register address and then set R/W to 1 to read data from the register.

Table 1 Write Data to Register in I²C Interface Mode

	Chip Address	R/W		Register Address		Data to be written		
start	0011 00 CE	0	ACK	RAM	ACK	DATA	ACK	Stop

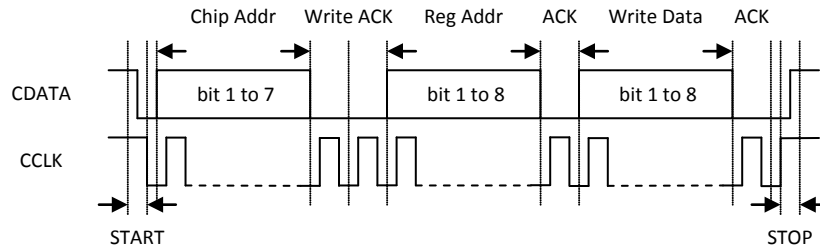

Figure 1a I²C Write Timing

Table 2 Read Data from Register in I²C Interface Mode

	Chip Address	R/W		Register Address		
Start	0011 00 CE	0	ACK	RAM	ACK	
	Chip Address	R/W		Data to be read		
Start	0011 00 CE	1	ACK	Data	NACK	Stop

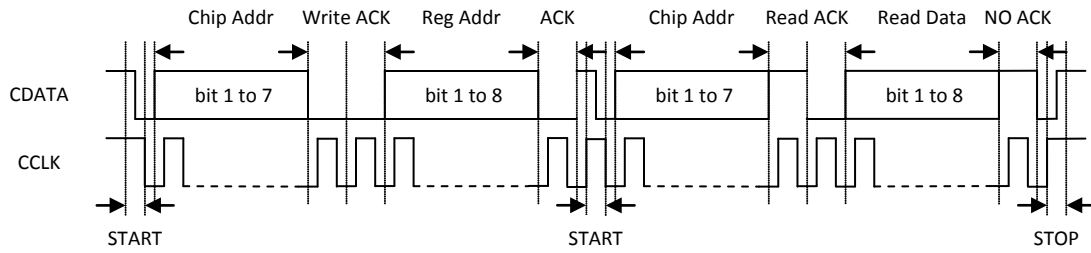

Figure 1b I²C Read Timing

6. DIGITAL AUDIO INTERFACE

The device provides many formats of serial audio data interface to the input of the DAC or output from the ADC through LRCK, SCLK and DSDIN or ASDOUT pins. These formats are I²S, left justified, right justified and DSP/PCM. DAC input DSDIN is sampled by the device on the rising edge of SCLK. ADC data is out at ASDOUT on the falling edge of SCLK. The relationship of SDATA (DSIN/ASDOUT), SCLK and LRCK with these formats are shown through Figure 2a to Figure 2d.

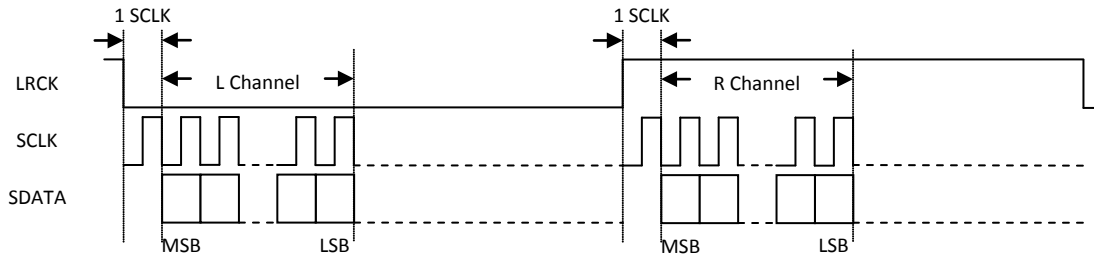

Figure 2a I²S Serial Audio Data Format

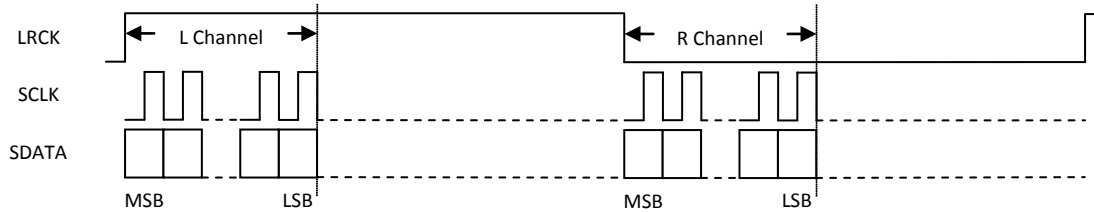

Figure 2b Left Justified Serial Audio Data Format

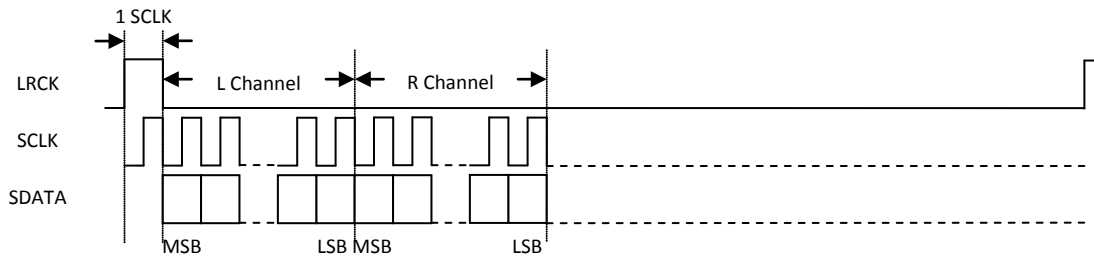

Figure 2c DSP/PCM Mode A Serial Audio Data Format

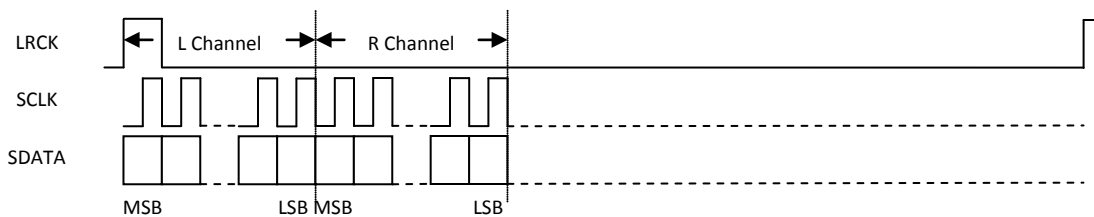

Figure 2d DSP/PCM Mode B Serial Audio Data Format

7. ELECTRICAL CHARACTERISTICS

ABSOLUTE MAXIMUM RATINGS

Continuous operation at or beyond these conditions may permanently damage the device.

PARAMETER	MIN	MAX
Analog Supply Voltage Level	-0.3V	+3.6V
Digital Supply Voltage Level	-0.3V	+3.6V
Analog Input Voltage Range	AGND-0.3V	AVDD+0.3V
Digital Input Voltage Range	DGND-0.3V	PVDD+0.3V
Operating Temperature Range	-40°C	+105°C
Storage Temperature	-65°C	+150°C

RECOMMENDED OPERATING CONDITIONS

PARAMETER	MIN	TYP	MAX	UNIT
DVDD	1.6	3.3	3.6	V
PVDD	1.6	3.3	3.6	V
AVDD	1.7	3.3	3.6	V

ADC ANALOG AND FILTER CHARACTERISTICS AND SPECIFICATIONS

Test conditions are as the following unless otherwise specify: AVDD=3.3V, DVDD=3.3V, AGND=0V, DGND=0V, Ambient temperature=25°C, Fs=48 KHz, MCLK/LRCK=256.

PARAMETER	MIN	TYP	MAX	UNIT
ADC Performance				
Signal to Noise ratio (A-weight)	95	100	102	dB
THD+N	-95	-93	-85	dB
Gain Error			±5	%
Filter Frequency Response – Single Speed				
Passband	0		0.4535	Fs
Stopband	0.5465			Fs
Passband Ripple			±0.05	dB
Stopband Attenuation	70			dB
Filter Frequency Response – Double Speed				
Passband	0		0.4167	Fs
Stopband	0.5833			Fs
Passband Ripple			±0.005	dB
Stopband Attenuation	70			dB
Analog Input				
Full Scale Input Level		AVDD/3.3		Vrms
Input Impedance		6		KΩ

DAC ANALOG AND FILTER CHARACTERISTICS AND SPECIFICATIONS

Test conditions are as the following unless otherwise specify: AVDD=3.3V, DVDD=3.3V, AGND=0V, DGND=0V, Ambient temperature=25°C, Fs=48 KHz, MCLK/LRCK=256.

PARAMETER	MIN	TYP	MAX	UNIT
DAC Performance				
Signal to Noise ratio (A-weight)	100	110	115	dB
THD+N	-85	-80	-75	dB
Gain Error			±5	%
Filter Frequency Response – Single Speed				
Passband	0		0.4535	F _s
Stopband	0.5465			F _s
Passband Ripple			±0.05	dB
Stopband Attenuation	53			dB
Filter Frequency Response – Double Speed				
Passband	0		0.4167	F _s
Stopband	0.5833			F _s
Passband Ripple			±0.005	dB
Stopband Attenuation	56			dB
Analog Output				
Full Scale Output Level		AVDD/3.3		V _{rms}

DC CHARACTERISTICS

PARAMETER	MIN	TYP	MAX	UNIT
Normal Operation Mode				
DVDD=1.8V, PVDD=1.8V, AVDD=3.3V		8		mA
Power Down Mode				
DVDD=1.8V, PVDD=1.8V, AVDD=3.3V		0		µA
Digital Voltage Level				
Input High-level Voltage	0.7*PVDD			V
Input Low-level Voltage			0.5	V
Output High-level Voltage		PVDD		V
Output Low-level Voltage		0		V

SERIAL AUDIO PORT SWITCHING SPECIFICATIONS

PARAMETER	Symbol	MIN	MAX	UNIT
MCLK frequency			51.2	MHz
MCLK duty cycle		40	60	%
LRCK frequency			200	KHz
LRCK duty cycle		40	60	%
SCLK frequency			26	MHz
SCLK pulse width low	T _{SCLKL}	15		ns
SCLK Pulse width high	T _{SCLKH}	15		ns
SCLK falling to LRCK edge	T _{SLR}	-10	10	ns
SCLK falling to SDO _{OUT} valid	T _{SDO}	11		ns

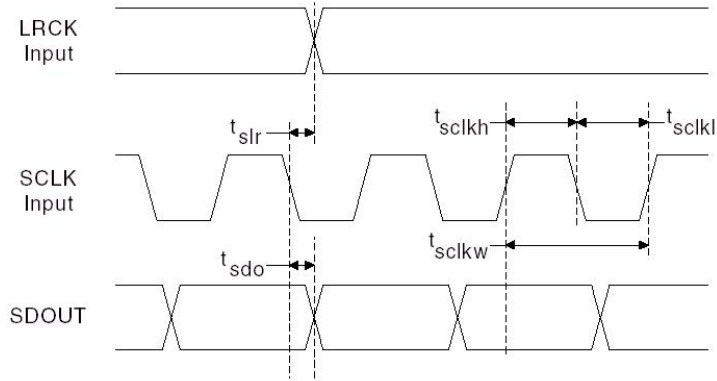

Figure 3 Serial Audio Port Timing

I²C SWITCHING SPECIFICATIONS

PARAMETER	Symbol	MIN	MAX	UNIT
CCLK Clock Frequency	F_{CCLK}		400	KHz
Bus Free Time Between Transmissions	T_{TWID}	1.3		us
Start Condition Hold Time	T_{TWSTH}	0.6		us
Clock Low time	T_{TWCL}	1.3		us
Clock High Time	T_{TWCH}	0.4		us
Setup Time for Repeated Start Condition	T_{TWSTS}	0.6		us
CDATA Hold Time from CCLK Falling	T_{TWDH}		900	ns
CDATA Setup time to CCLK Rising	T_{TWDS}	100		ns
Rise Time of CCLK	T_{TWR}		300	ns
Fall Time CCLK	T_{TWF}		300	ns

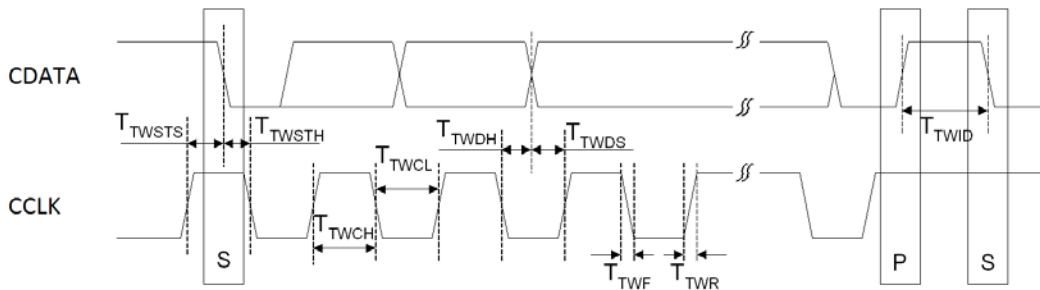

Figure 4 I²C Timing

9. CORPORATE INFORMATION

Everest Semiconductor Co., Ltd.

No. 1355 Jinjihu Drive, Suzhou Industrial Park, Jiangsu, P.R. China, Zip Code 215021

苏州工业园区金鸡湖大道 1355 号国际科技园, 邮编 215021

Email: info@everest-semi.com



X-ON Electronics

Largest Supplier of Electrical and Electronic Components

Click to view similar products for [Encoders, Decoders, Multiplexers & Demultiplexers](#) *category:*

Click to view products by [Everest Semiconductor](#) *manufacturer:*

Other Similar products are found below :

[MC74HC163ADTG](#) [74HC253N](#) [NLV74VHC1G01DFT1G](#) [NLVHCT4851ADTR2G](#) [COMX-CAR-210](#) [SN74LS148N](#)
[TC74VHC138F\(EL,K,F](#) [PI3B3251LE](#) [PI3B3251QE](#) [74VHC4052AFT\(BJ\)](#) [NLV74HC4851AMNTWG](#) [MC74LVX257DG](#)
[M74HCT4851ADWR2G](#) [NL7SZ19DBVT1G](#) [PI5C3253LEX](#) [MC74ACT138NG](#) [NB3L8533DTR2G](#) [NLV74AC157DR2G](#) [74HC138DT](#)
[74HC153DT](#) [74HC238DT](#) [74HC151DT](#) [74HC138D](#) [AIP74HC4053SA16.TR](#) [ES8311](#) [74HC238M/TR](#) [CD4543BE](#) [74HC138MT/TR](#)
[MC74HC151ADTG](#) [MC74LVX257DTR2G](#) [74VHC238FT\(BJ\)](#) [74VHC4066AFT\(BJ\)](#) [74VHCT138AFT\(BJ\)](#) [NC7SZ157P6X](#) [SN74HC148AN](#)
[74HC4052D\(BJ\)](#) [74VHC138MTC](#) [COMX-CAR-P1](#) [74VHC138MTCX](#) [74HC138D\(BJ\)](#) [SN74LS157NE4](#) [74AHCT138T16-13](#)
[74LCX138FT\(AJ\)](#) [74LCX157FT\(AJ\)](#) [NL7SZ18MUR2G](#) [74VHC139FT\(BJ\)](#) [74VHC157FT\(BJ\)](#) [TC74HC4052AFT-EL](#) [SN54LS138J](#)
[SN54HC138J](#)