

SMD ■ MID Power LED 67-21S/KK5C-HXXXXXXXXZ6/2T(CLW)



Features

- PLCC-2 package
- Top view white LED
- High luminous intensity output
- Wide viewing angle
- Pb-free
- RoHS compliant
- ANSI Binning

Description

The Everlight 67-21S package has high efficacy, high CRI, low power consumption, wide viewing angle and a compact form factor. These features make this package an ideal LED for all lighting applications.

Applications

- General lighting
- Decorative and Entertainment Lighting
- Indicators
- Illumination
- Switch lights

Product Number Explanation

67-21S/ K K5C – H XX XX XX Z6 / 2 T

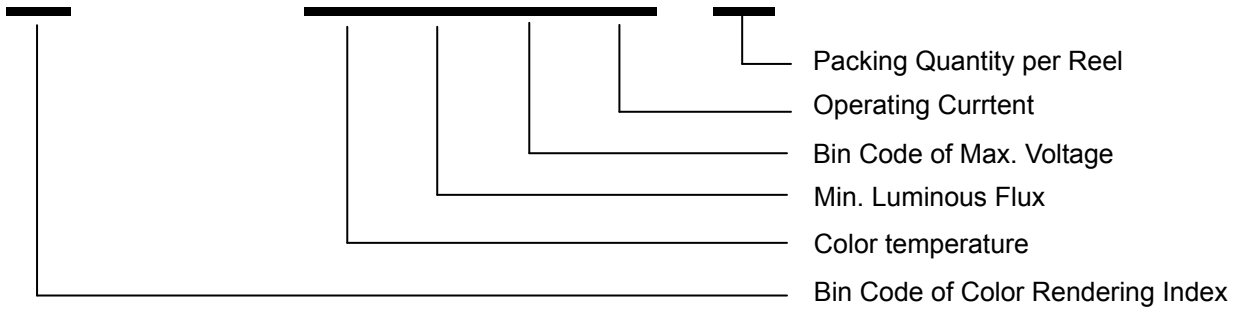

Table of Color Rendering Index

Symbol	Description
M	CRI(Min.) : 60
N	CRI(Min.) : 65
L	CRI(Min.) : 70
Q	CRI(Min.) : 75
K	CRI(Min.) : 80
P	CRI(Min.) : 85
H	CRI(Min.) : 90

Note:
 Tolerance of Color Rendering Index: ±3

Table of Forward Current Index

Symbol	Description
Z6	I _F :60mA

Table of Forward Voltage Index

Symbol	Description
33	3.3V max

Example:
 67-21S/KK5C-H572633Z6/2T(CLW)

CRI	80(Min.)
CCT	5700K
Flux	26lm min
V _F	3.3V max
I _F	60mA

Mass Production List

Product	CRI Min. ⁽¹⁾	CCT(K)	Φ(lm) Min. ⁽²⁾
67-21S/KK5C-H272333Z6/2T(CLW)	80	2700K	23
67-21S/KK5C-H302433Z6/2T(CLW)	80	3000K	24
67-21S/KK5C-H402633Z6/2T(CLW)	80	4000K	26
67-21S/KK5C-H502633Z6/2T(CLW)	80	5000K	26
67-21S/KK5C-H572633Z6/2T(CLW)	80	5700K	26
67-21S/KK5C-H652633Z6/2T(CLW)	80	6500K	26

Notes:

1. Tolerance of Color Rendering Index: ± 3
2. Tolerance of Luminous flux: $\pm 11\%$.

Device Selection Guide

Chip Materials	Emitted Color	Resin Color
InGaN	Cool White Neutral White Warm White	Water Clear

Absolute Maximum Ratings (T_{Soldering}=25°C)

Parameter	Symbol	Rating	Unit
Forward Current	I _F	75	mA
Peak Forward Current (Duty 1/10 @10ms)	I _{FP}	100	mA
Power Dissipation	P _d	250	mW
Operating Temperature	T _{opr}	-40 ~ +85	°C
Storage Temperature	T _{stg}	-40 ~ +100	°C
Thermal Resistance (Junction / Soldering point)	R _{th J-S}	50	°C/W
Junction Temperature	T _j	125	°C
Soldering Temperature	T _{sol}	Reflow Soldering : 260 °C for 10 sec. Hand Soldering : 350 °C for 3 sec.	

Note:

The products are sensitive to static electricity and must be carefully taken when handling products

Electro-Optical Characteristics (T_{Soldering}=25°C)

Parameter	Symbol	Min.	Typ.	Max.	Unit	Condition
Luminous Flux ₍₁₎	Φ	23	----	----	lm	I _F =60mA
Forward Voltage ₍₂₎	V _F	----	----	3.3	V	I _F =60mA
Color Rendering Index ₍₃₎	Ra	80	----	----		I _F =60mA
Viewing Angle	2θ _{1/2}	----	120	----	deg	I _F =60mA
Reverse Current	IR	----	----	50		V _R =5V

Notes:

1. Tolerance of Luminous flux: ±11%.
2. Tolerance of Forward Voltage: ±0.1V.
3. Tolerance of Color Rendering Index: ±2

Bin Range of Luminous Flux

Bin Code	Min.	Max.	Unit	Condition
M42	23	24	lm	I _F =60mA
N3	24	27		
N32	26	27		
N4A	27	30		
N4B	30	33		

Note:
 Tolerance of Luminous flux: ±11%.

Bin Range of Forward Voltage

Group	Bin Code	Min.	Max.	Unit	Condition
2833	35	2.8	2.9	V	I _F =60mA
	36	2.9	3.0		
	37	3.0	3.1		
	38	3.1	3.2		
	39	3.2	3.3		

Note:
 Tolerance of Forward Voltage: ±0.1V.

The C.I.E. 1931 Chromaticity Diagram

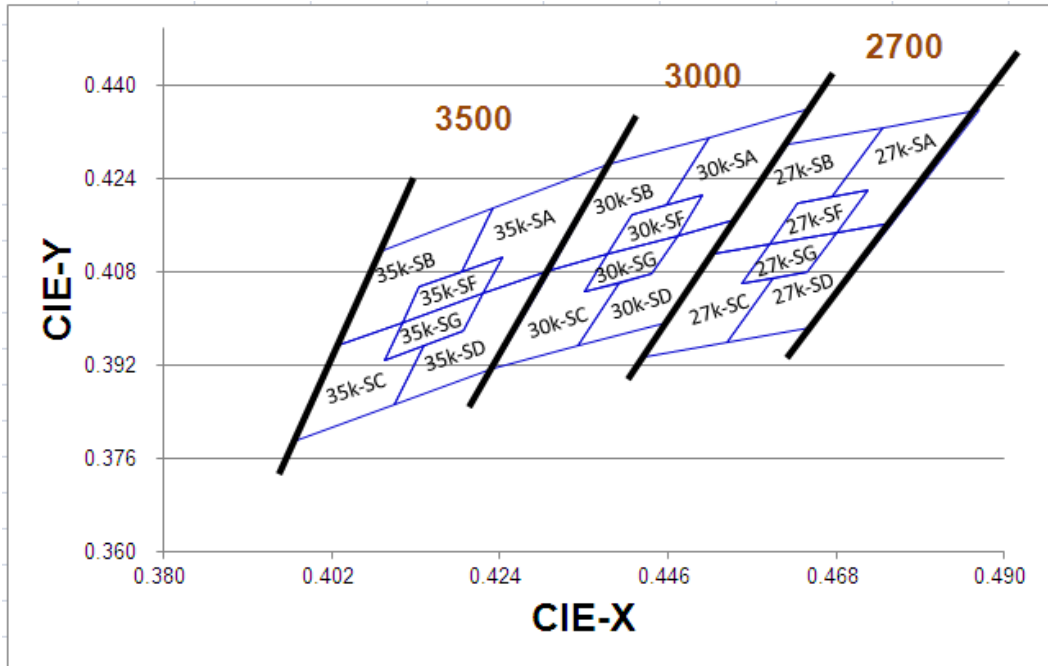

Bin Range of Chromaticity Coordinates

CCT	Bin Code	CIE_x	CIE_y	Bin Code	CIE_x	CIE_y	
2700K	27K-SA	0.4867	0.4359	27K-SD	0.4754	0.4166	
		0.4741	0.4329		0.4681	0.4149	
		0.4675	0.4209		0.4642	0.4081	
		0.4721	0.4220		0.4598	0.4070	
		0.4681	0.4149		0.4537	0.3959	
		0.4754	0.4166		0.4647	0.3984	
	Reference Range:2540K~2680K						
	27K-SB	0.4741	0.4329	27K-SC	0.4519	0.4111	
		0.4616	0.4300		0.4427	0.3933	
		0.4519	0.4111		0.4537	0.3959	
		0.4593	0.4128		0.4598	0.4070	
		0.4630	0.4198		0.4556	0.4060	
		0.4675	0.4209		0.4593	0.4128	
	Reference Range:2675K~2825K						
	27K-SF	0.4721	0.4220	27K-SG	0.4681	0.4149	
		0.4630	0.4198		0.4593	0.4128	
		0.4593	0.4128		0.4556	0.4060	
		0.4681	0.4149		0.4642	0.4081	
	Reference Range: 2620K~2730K						

The C.I.E. 1931 Chromaticity Diagram

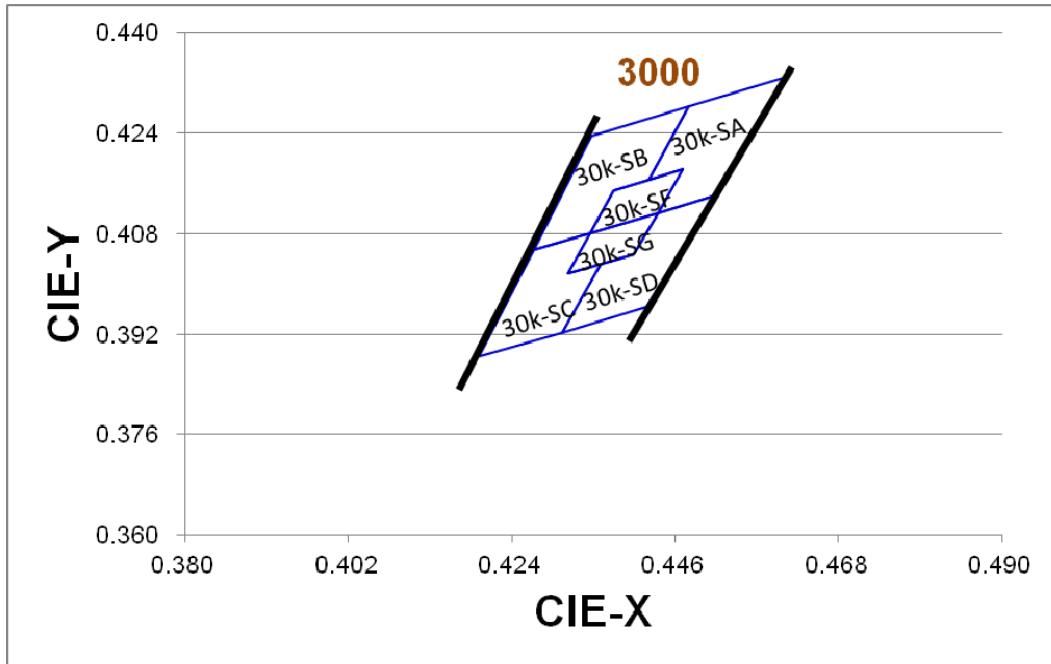

Bin Range of Chromaticity Coordinates

CCT	Bin Code	CIE_x	CIE_y	Bin Code	CIE_x	CIE_y	
3000K	30K-SA	0.4611	0.4330	30K-SD	0.4514	0.4141	
		0.4479	0.4282		0.4437	0.4113	
		0.4424	0.4166		0.4404	0.4047	
		0.4471	0.4183		0.4360	0.4032	
		0.4437	0.4113		0.4308	0.3923	
		0.4514	0.4141		0.4422	0.3963	
	Reference Range:2865K~3030K						
	30K-SB	0.4479	0.4282	30K-SC	0.4270	0.4054	
		0.4348	0.4235		0.4196	0.3884	
		0.4270	0.4054		0.4308	0.3923	
		0.4346	0.4081		0.4360	0.4032	
		0.4377	0.4149		0.4316	0.4016	
		0.4424	0.4166		0.4346	0.4081	
	Reference Range:3025K~3200K						
	30K-SF	0.4471	0.4183	30K-SG	0.4437	0.4113	
		0.4377	0.4149		0.4346	0.4081	
		0.4346	0.4081		0.4316	0.4016	
		0.4437	0.4113		0.4404	0.4047	
	Reference Range:2960K~3090K						

The C.I.E. 1931 Chromaticity Diagram

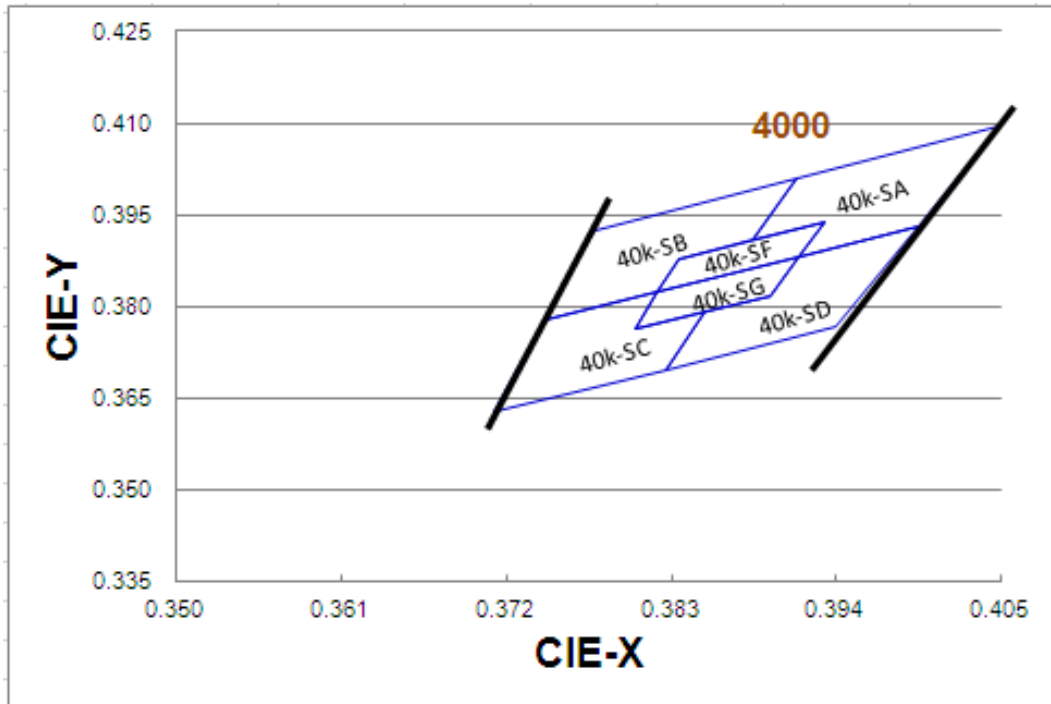

Bin Range of Chromaticity Coordinates

CCT	Bin Code	CIE_x	CIE_y	Bin Code	CIE_x	CIE_y	
4000K	40K-SA	0.4048	0.4094	40K-SD	0.3994	0.3930	
		0.3913	0.4009		0.3915	0.3881	
		0.3885	0.3908		0.3896	0.3818	
		0.3932	0.3937		0.3852	0.3791	
		0.3915	0.3881		0.3826	0.3697	
		0.3994	0.3930		0.3940	0.3766	
	Reference Range:3650K~3900K						
	40K-SB	0.3913	0.4009	40K-SC	0.3745	0.3776	
		0.3778	0.3924		0.3712	0.3628	
		0.3745	0.3776		0.3826	0.3697	
		0.3821	0.3823		0.3852	0.3791	
		0.3835	0.3878		0.3806	0.3763	
0.3885		0.3908	0.3821		0.3823		
Reference Range:3900K~4180K							
40K-SF	0.3932	0.3937	40K-SG	0.3915	0.3881		
	0.3835	0.3878		0.3821	0.3823		
	0.3821	0.3823		0.3806	0.3763		
	0.3915	0.3881		0.3896	0.3818		
Reference Range:3800K~4000K							

The C.I.E. 1931 Chromaticity Diagram

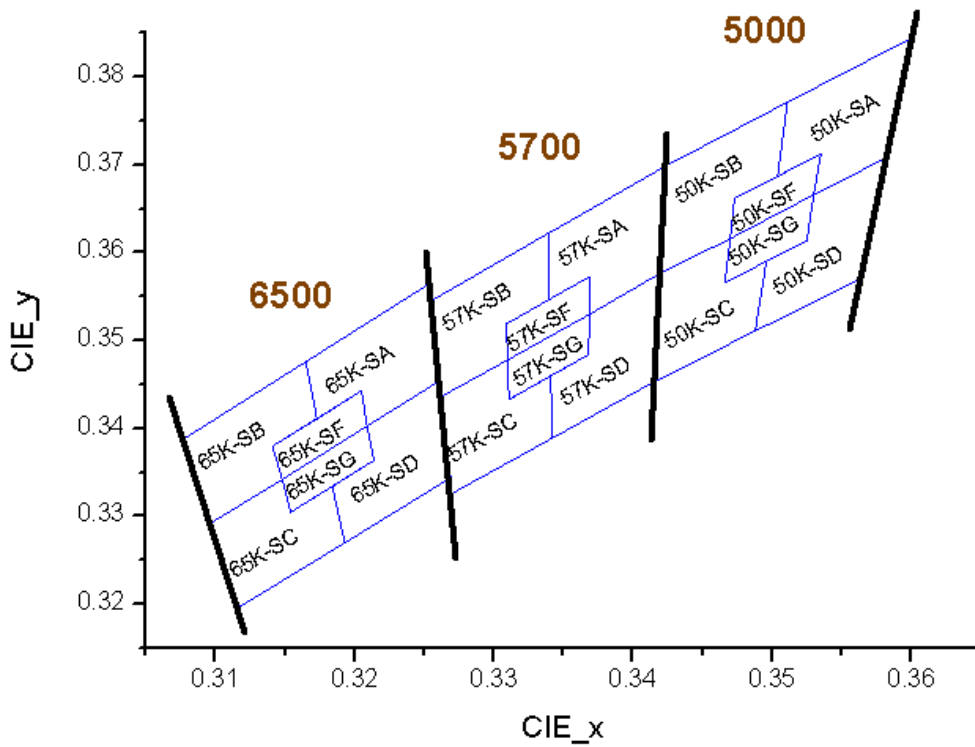

Bin Range of Chromaticity Coordinates

CCT	Bin Code	CIE_x	CIE_y	Bin Code	CIE_x	CIE_y	
5000K	50K-SA	0.3599	0.3843	50K-SD	0.3581	0.3707	
		0.3511	0.3771		0.3530	0.3666	
		0.3504	0.3687		0.3525	0.3613	
		0.3535	0.3712		0.3496	0.3590	
		0.3530	0.3666		0.3488	0.3511	
		0.3581	0.3707		0.3563	0.3570	
	Reference Range:4630K~4880K						
	50K-SB	0.3511	0.3771	50K-SC	0.3419	0.3576	
		0.3424	0.3699		0.3414	0.3452	
		0.3419	0.3576		0.3488	0.3511	
		0.3470	0.3616		0.3496	0.3590	
		0.3473	0.3662		0.3466	0.3566	
		0.3504	0.3687		0.3470	0.3616	
	Reference Range:4870K~5150K						
	50K-SF	0.3535	0.3712	50K-SG	0.3530	0.3666	
		0.3473	0.3662		0.3470	0.3616	
		0.3470	0.3616		0.3466	0.3566	
		0.3530	0.3666		0.3525	0.3613	
	Reference Range:4770K~4970K						

CCT	Bin Code	CIE_x	CIE_y	Bin Code	CIE_x	CIE_y	
5700K	57K-SA	0.3424	0.3699	57K-SD	0.3419	0.3576	
		0.3339	0.3622		0.3369	0.3530	
		0.3340	0.3547		0.3368	0.3484	
		0.3369	0.3573		0.3341	0.3460	
		0.3369	0.3530		0.3342	0.3389	
		0.3419	0.3576		0.3414	0.3452	
	Reference Range:5140K~5450K						
	57K-SB	0.3339	0.3622	57K-SC	0.3262	0.3436	
		0.3255	0.3545		0.3270	0.3326	
		0.3262	0.3436		0.3342	0.3389	
		0.3310	0.3478		0.3341	0.3460	
		0.3309	0.3519		0.3311	0.3433	
		0.3340	0.3547		0.3310	0.3478	
	Reference Range:5440K~5790K						
	57K-SF	0.3369	0.3573	57K-SG	0.3369	0.3530	
		0.3309	0.3519		0.3310	0.3478	
		0.3310	0.3478		0.3311	0.3433	
		0.3369	0.3530		0.3368	0.3484	
	Reference Range:5320K~5570K						

CCT	Bin Code	CIE_x	CIE_y	Bin Code	CIE_x	CIE_y	
6500K	65K-SA	0.3253	0.3564	65K-SD	0.3261	0.3454	
		0.3165	0.3476		0.3209	0.3403	
		0.3173	0.3411		0.3214	0.3364	
		0.3205	0.3443		0.3184	0.3334	
		0.3209	0.3403		0.3193	0.3270	
		0.3261	0.3454		0.3269	0.3344	
	Reference Range:5800K~6210K						
	65K-SB	0.3165	0.3476	65K-SC	0.3096	0.3292	
		0.3076	0.3387		0.3116	0.3196	
		0.3096	0.3292		0.3193	0.3270	
		0.3148	0.3342		0.3184	0.3334	
		0.3141	0.3380		0.3154	0.3305	
		0.3173	0.3411		0.3148	0.3342	
	Reference Range:6210K~6700K						
	65K-SF	0.3205	0.3443	65K-SG	0.3209	0.3403	
		0.3141	0.3380		0.3148	0.3342	
		0.3148	0.3342		0.3154	0.3305	
		0.3209	0.3403		0.3214	0.3364	
	Reference Range:6040K~6380K						

Notes:

1. The value is based on driving current by 60mA.
2. Tolerance of Chromaticity Coordinates: ± 0.01 .

Spectrum Distribution

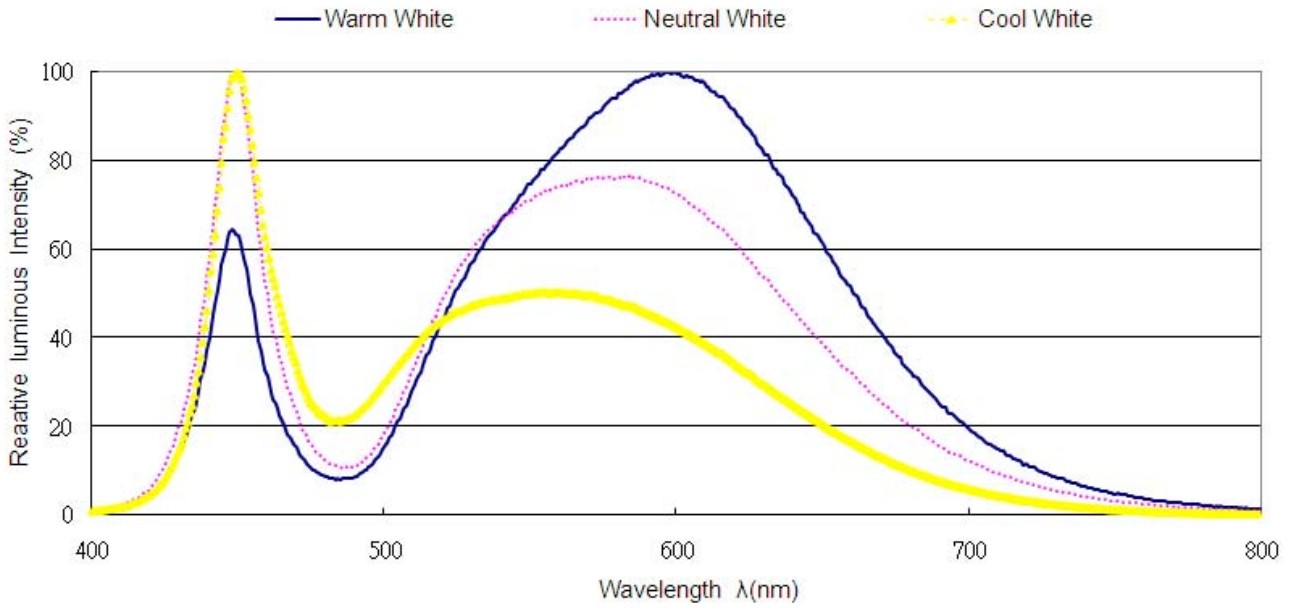

Typical Electro-Optical Characteristics Curves

Fig.1 – Forward Voltage Shift vs. Junction Temperature

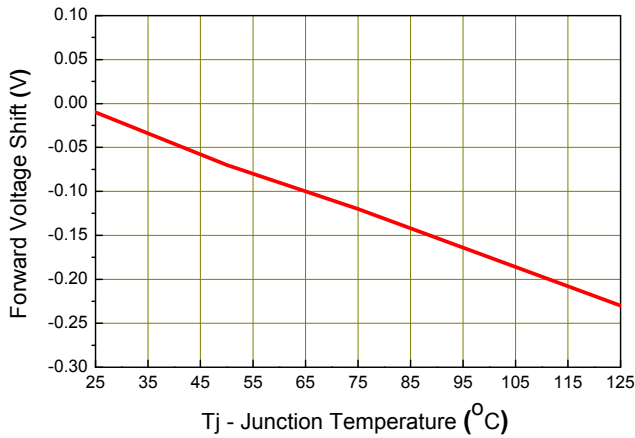
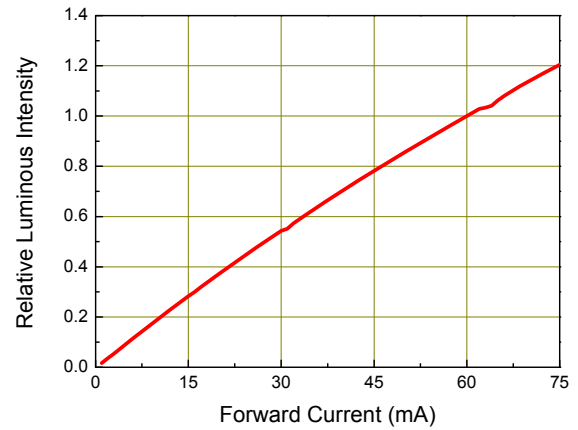

Fig.2 - Relative Luminous Intensity vs. Forward Current



Typical Electro-Optical Characteristics Curves

Fig.3 - Relative Luminous Intensity vs. Junction Temperature

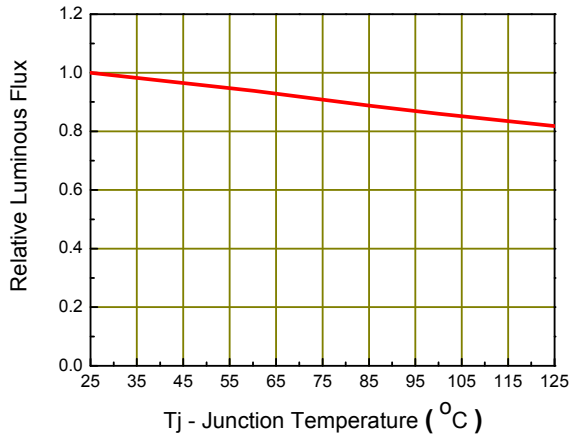

Fig.4 - Forward Current vs. Forward Voltage

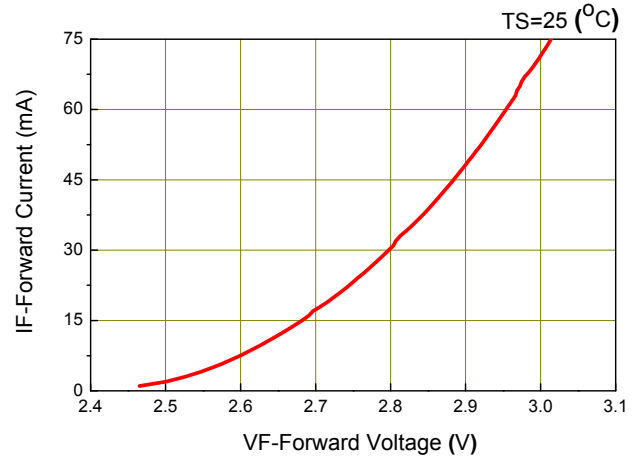

Fig.5 - Max. Driving Forward Current vs. Soldering Temperature

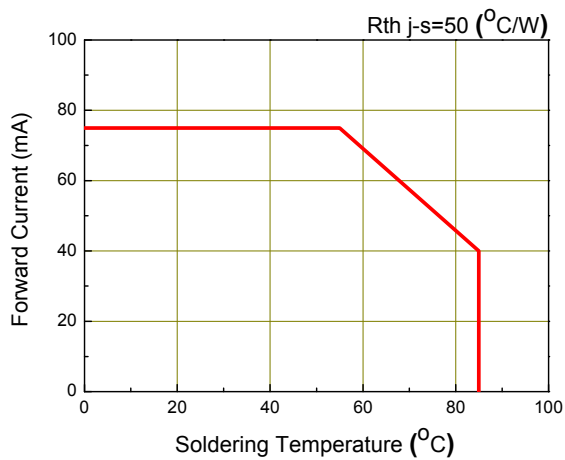
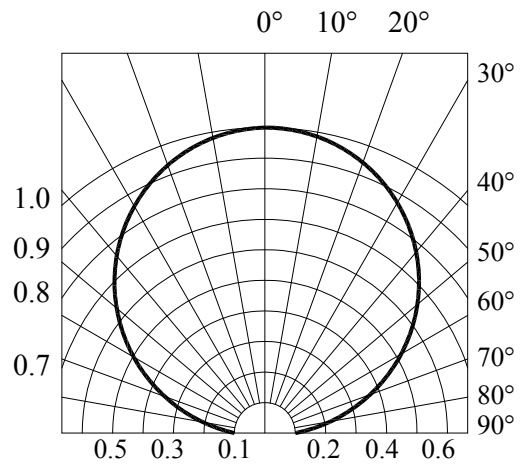
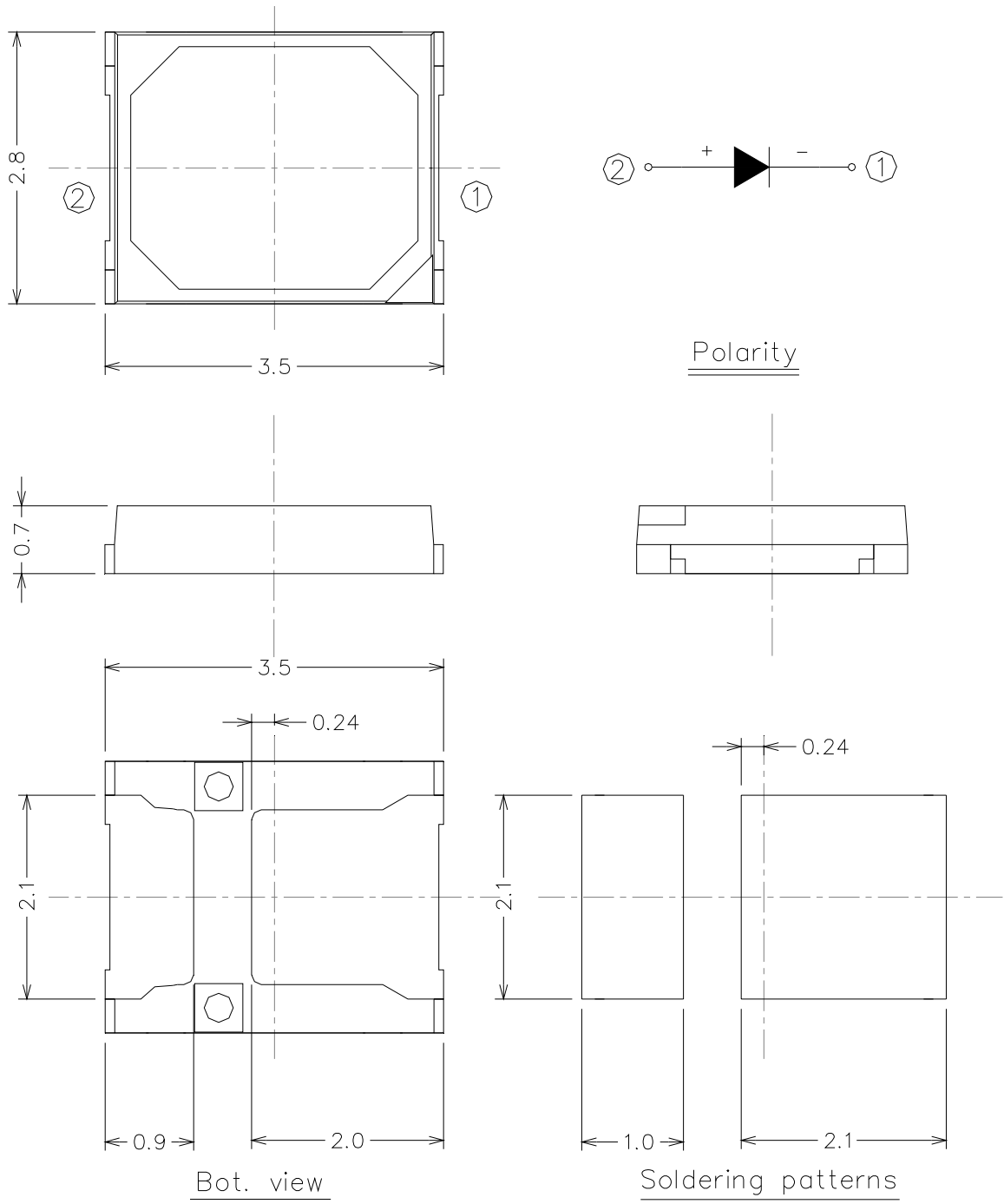

Fig.6 - Radiation Diagram



Package Dimension



Note:
Tolerance unless mentioned is ± 0.15 mm; Unit = mm

Moisture Resistant Packing Materials

Label Explanation

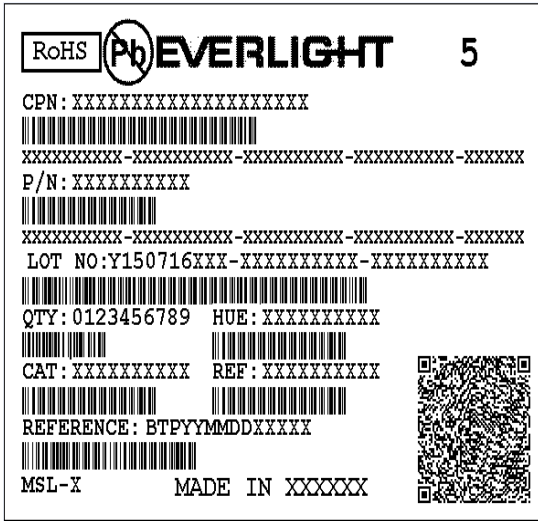

- CPN: Customer's Product Number
- P/N: Product Number
- QTY: Packing Quantity
- CAT: Luminous Intensity Rank
- HUE: Dom. Wavelength Rank
- REF: Forward Voltage Rank
- LOT No: Lot Number

Reel Dimensions

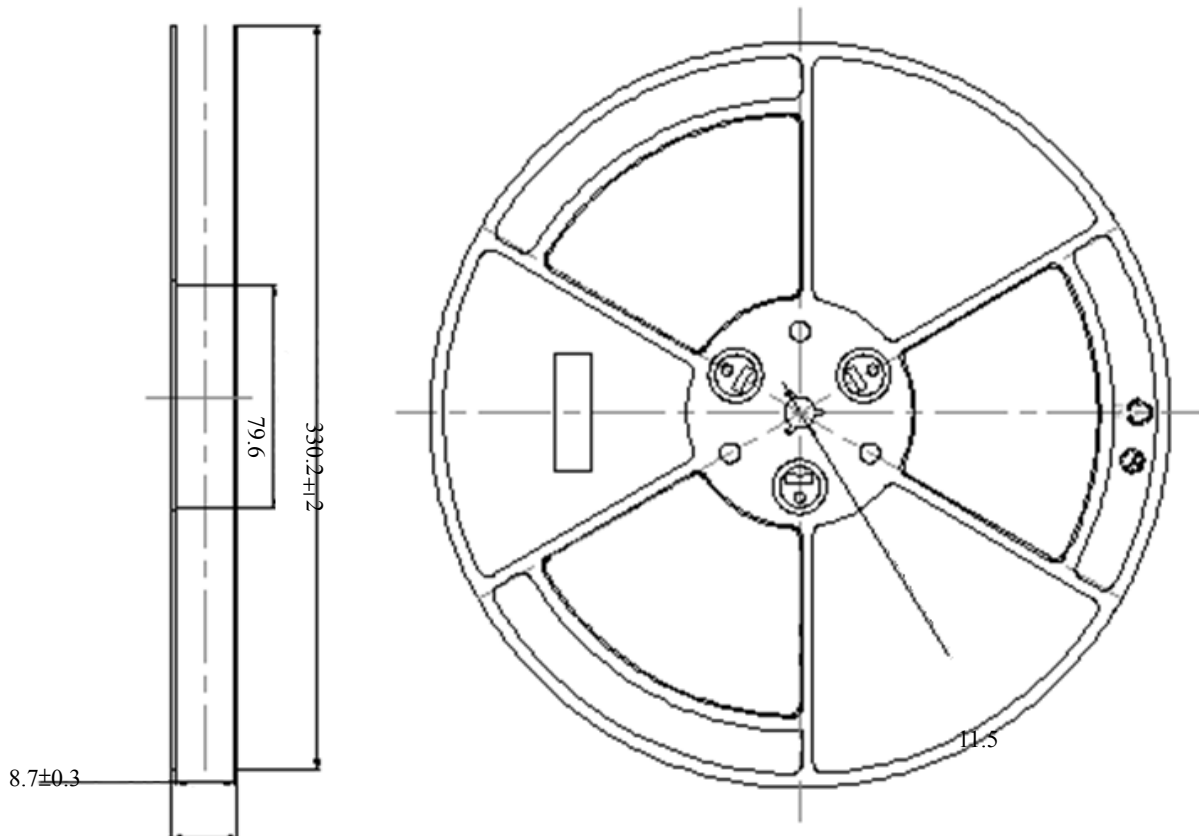

Note:
 Tolerances unless mentioned ± 0.1 mm. Unit = mm

Carrier Tape Dimensions: Loaded Quantity 16000 pcs Per Reel

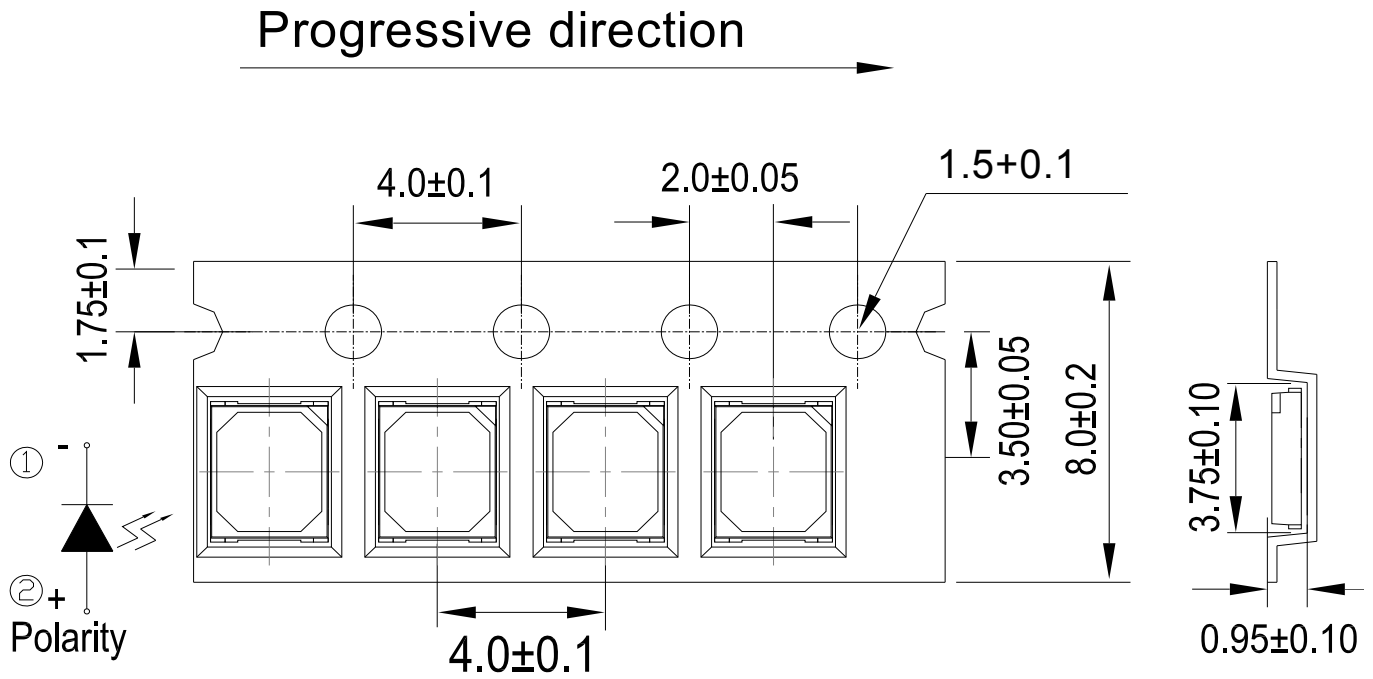

Note:
 Tolerance unless mentioned is $\pm 0.1\text{mm}$; Unit = mm

Moisture Resistant Packing Process(2 Reels / Bag)

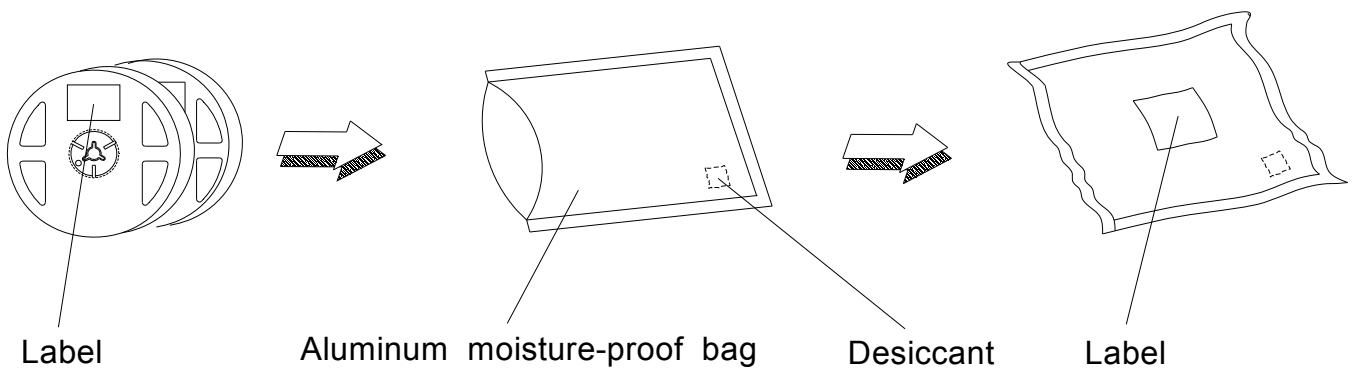

Reliability Test Items and Conditions

The reliability of products shall be satisfied with items listed below.
Confidence level : 90%
LTPD : 10%

No.	Items	Test Condition	Test Hours/Cycles	Sample Size	Ac/Re
1	Reflow Soldering	Temp. : 260°C /10sec.	6 Min.	22 PCS.	0/1
2	Thermal Shock	H : +100°C 20min ∫ 10 sec L : -10°C 20min	200 Cycles	22 PCS.	0/1
3	Temperature Cycle	H : +100°C 30min ∫ 5 min L : -40°C 30min	200 Cycles	22 PCS.	0/1
4	High Temperature/Humidity Reverse Bias	Ta=85°C,85%RH	1000 Hrs.	22 PCS.	0/1
5	High Temperature/Humidity Operation	Ta=85°C,85%RH, I _F = 40 mA	1000 Hrs.	22 PCS.	0/1
6	Low Temperature Storage	Ta=-40°C	1000 Hrs.	22 PCS.	0/1
7	High Temperature Storage	Ta=85°C	1000 Hrs.	22 PCS.	0/1
8	Low Temperature Operation Life	Ta=-40°C, I _F = 75 mA	1000 Hrs.	22 PCS.	0/1
9	High Temperature Operation/ Life#1	Ta=25°C, I _F = 75 mA	1000 Hrs.	22 PCS.	0/1
10	High Temperature Operation/ Life#2	Ta=55°C, I _F =75 mA	1000 Hrs.	22 PCS.	0/1
11	High Temperature Operation/ Life#3	Ta=85°C, I _F = 40 mA	1000 Hrs.	22 PCS.	0/1

Precautions for Use

1. Over-current-proof

Customer must apply resistors for protection; otherwise slight voltage shift will cause big current change (Burn out will happen).

2. Storage

2.1 Do not open moisture proof bag before the products are ready to use.

2.2 Before opening the package: The LEDs should be kept at 30°C or less and 90%RH or less.

2.3 After opening the package: The LED's floor life is 168 Hrs under 30°C or less and 60% RH or less. If unused LEDs remain, it should be stored in moisture proof packages.

2.4 If the moisture absorbent material (silica gel) has faded away or the LEDs have exceeded the storage time, baking treatment should be performed using the following conditions.

Baking treatment: 60±5°C for 24 hours.

3. Soldering Condition

3.1 Pb-free solder temperature profile

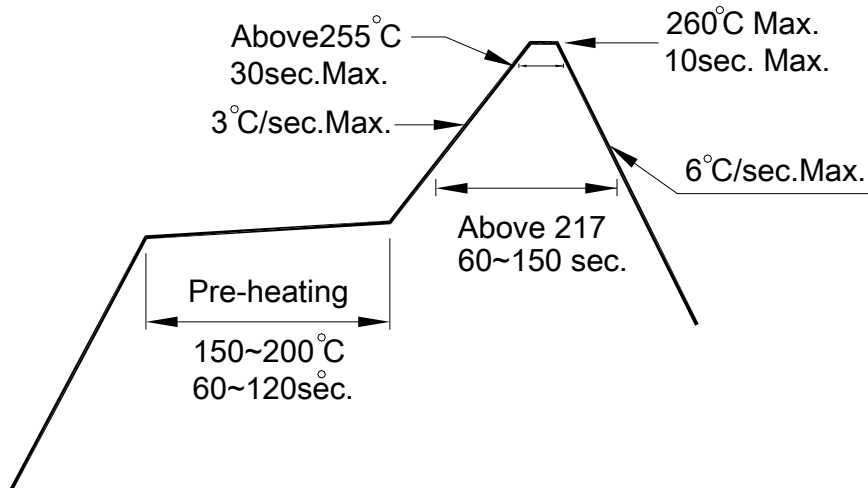

3.2 Reflow soldering should not be done more than two times.

3.3 When soldering, do not put stress on the LEDs during heating.

3.4 After soldering, do not warp the circuit board.

4. Soldering Iron

Each terminal is to go to the tip of soldering iron temperature less than 350°C for 3 seconds within once in less than the soldering iron capacity 25W. Leave two seconds and more intervals, and do soldering of each terminal. Be careful because the damage of the product is often started at the time of the hand solder.

5. Repairing

Repair should not be done after the LEDs have been soldered. When repairing is unavoidable, a double-head soldering iron should be used (as below figure). It should be confirmed beforehand whether the characteristics of the LEDs will or will not be damaged by repairing.

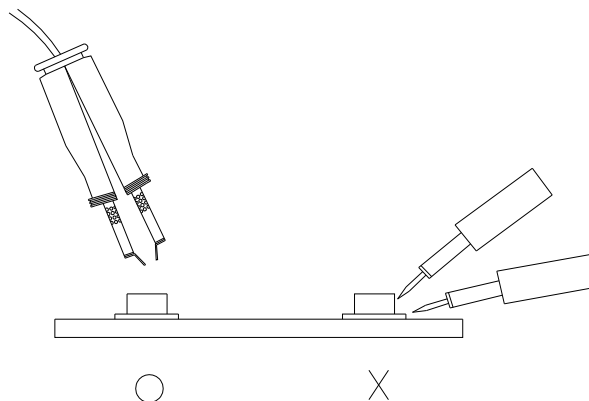

X-ON Electronics

Largest Supplier of Electrical and Electronic Components

Click to view similar products for [Standard LEDs - SMD category](#):

Click to view products by [Everlight manufacturer](#):

Other Similar products are found below :

[LTST-C190KYKT](#) [LTST-C19GD2WT](#) [LTST-N683GBEW](#) [LTW-170ZDC](#) [LTW-M140SZS40](#) [LTW-M140ZVS](#) [598-8110-100F](#) [598-8170-100F](#) [598-8610-202F](#) [AAAF5060QBFSEEZGS](#) [ALMD-LB36-SV002](#) [APT1608QGW](#) [EAST2012YA0](#) [EASV1803BA0](#) [SML-512VWT86A](#) [SML-LX0606SISUGC/A](#) [SML-LXL1307SRC-TR](#) [SML-LXR851SIUPGUBC](#) [LT1ED53A](#) [AM27ZGC03](#) [APB3025SGNC](#) [APFA3010SURKCGKQBDC](#) [APHK1608VGCA](#) [APT2012QGW](#) [CLX6D-FKB-CN1R1H1BB7D3D3](#) [LTST-008BGEW](#) [LTW-020ZDCG](#) [LTW-21TS5](#) [LTW-220DS5](#) [598-8330-117F](#) [SML-LX0402IC-TR](#) [CMDA20AYAA7D1S](#) [CMDA16AYDR7A1X](#) [91-21SYGD/S530-E2/TR7](#) [598-8040-100F](#) [598-8070-100F](#) [598-8140-100F](#) [598-8610-200F](#) [EAST2012GA0](#) [EAPL3527GA5](#) [SML-LXL1209SYC/ATR](#) [EAST2012RA0](#) [CMD91-21VRC/TR7](#) [SML-LXR851SGSIC-TR](#) [SML-512PWT86A](#) [SMF-2432GYC-TR](#) [LTST-C194TBKT-5A](#) [CLX6E-FKC-CH1M1D1BB7C3D3](#) [SML-LXL0805USBC-TR](#) [SML-LX2835SYSUGCTR](#)