

Technical Data Sheet

Top View LEDs

67-23UWC/S400-X9/S612-1/TR8

Features

- Fluorescence Type
- High Luminous Intensity
- High Efficiency
- Emission Color:x=0.29,y=0.30
- Pb-free.
- Available on tape and reel (8mm Tape).
- The product itself will remain within RoHS compliant version.



Descriptions

The white LED which was fabricated using a blue LED and a phosphor, and the phosphor is excited by blue light and emits yellow fluorescence. The mixture of blue light and yellow light results in a white emission.

Applications

- OA Equipment
- Backlighting of Full Color LCD
- Automotive Equipment
- Replacement of Conventional Light Bulbs and Fluorescent Lamps

Device Selection Guide

Chip	Emitted Color	Resin Color
Material		
InGaN	White	Water Clear

Technical Data Sheet

Top View LEDs

67-23UWC/S400-X9/S612-1/TR8

Package Outline Dimensions

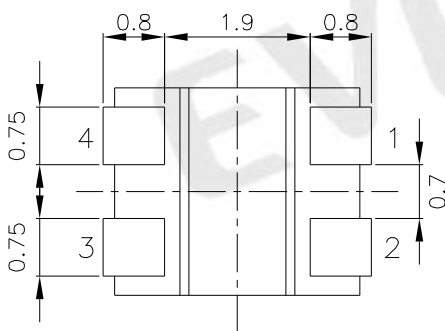
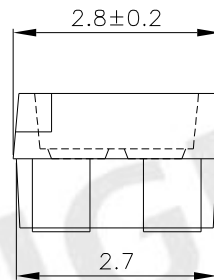
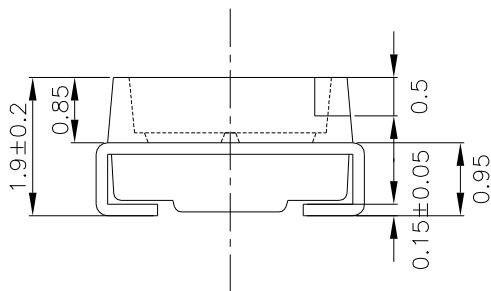
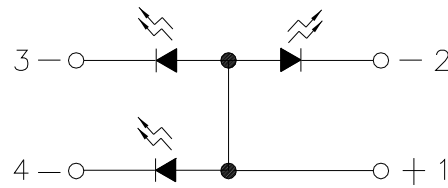
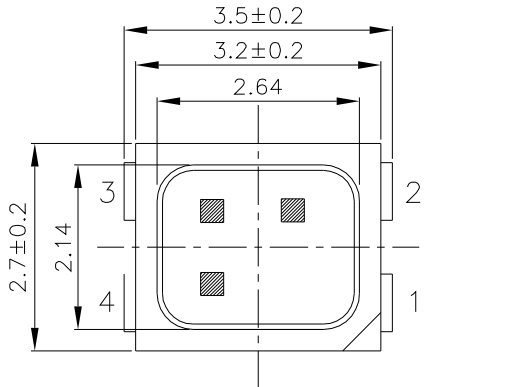

Recommended Solder Pad

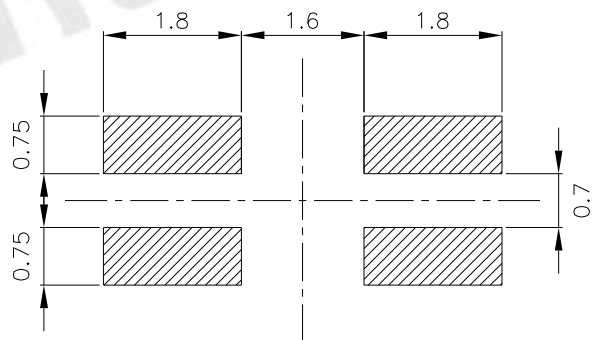

Technical Data Sheet

Top View LEDs

67-23UWC/S400-X9/S612-1/TR8

Absolute Maximum Ratings (Ta=25)

Parameter	Symbol	Rating	Unit
Reverse Voltage	V _R	5	V
Forward Current	I _F	25	mA
Peak Forward Current(Duty 1/10 @ 1KHz)	I _{FP}	100	mA
Power Dissipation	P _d	110	mW
Electrostatic Discharge(HBM)	ESD	150	V
Operating Temperature	T _{opr}	-40 ~ +85	
Storage Temperature	T _{stg}	-40~ +90	
Soldering Temperature	T _{sol}	Reflow Soldering : 260 Hand Soldering : 350	for 10 sec. for 3 sec.

Electro-Optical Characteristics (Ta=25)

Parameter	Symbol	Min.	Typ.	Max.	Units	Condition
Luminous Intensity*1	I _V	1045	1500	--	mcd	I _F =20mA ^{*2}
Viewing Angle	2 1/2	--	120	--	deg	I _F =20mA
Forward Voltage*2	V _F	--	3.5	4.0	V	I _F =20mA
Reverse Current*2	I _R	--	--	50	μA	V _R =5V

*1 When three LED die are operated simultaneously.

*2 For each die.

Notes :

1. Tolerance of Luminous Intensity : ±11%
2. Tolerance of Forward Voltage : ±0.1V

Technical Data Sheet

Top View LEDs

67-23UWC/S400-X9/S612-1/TR8

Bin Range of Chromaticity Coordinates

	Rank A0			
x	0.280	0.264	0.283	0.296
y	0.248	0.267	0.305	0.276

	Rank B1			
x	0.287	0.283	0.330	0.330
y	0.295	0.305	0.360	0.339

	Rank B2			
x	0.296	0.287	0.330	0.330
y	0.276	0.295	0.339	0.318

	Rank C0			
x	0.330	0.330	0.361	0.356
y	0.318	0.360	0.385	0.351

Notes:

1. The C.I.E. 1931 chromaticity diagram (Tolerance ± 0.01).
2. The products are sensitive to static electricity and care must be fully taken when handling products.

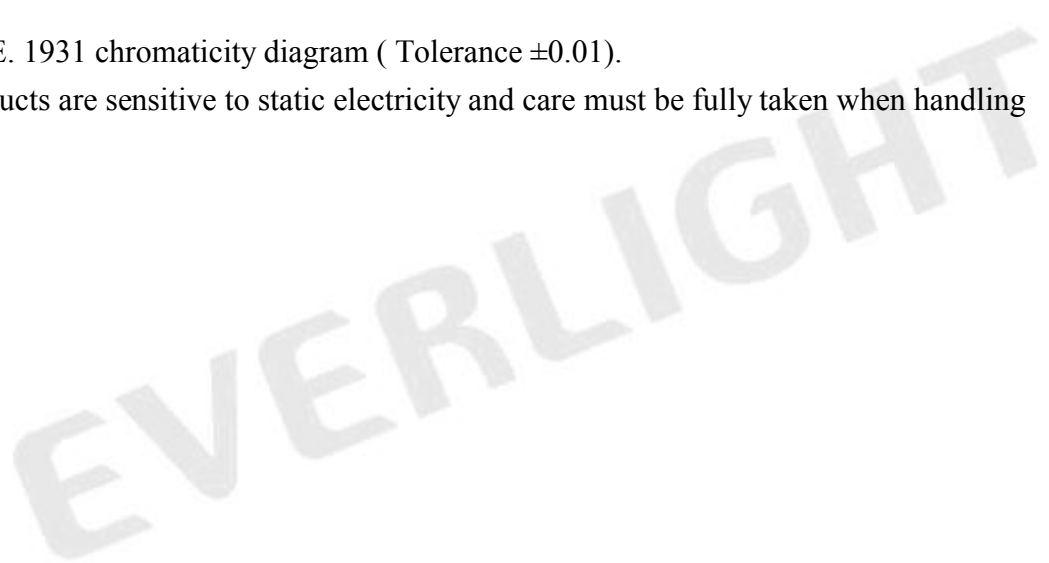

Technical Data Sheet

Top View LEDs

67-23UWC/S400-X9/S612-1/TR8

The C.I.E. 1931 Chromaticity Diagram

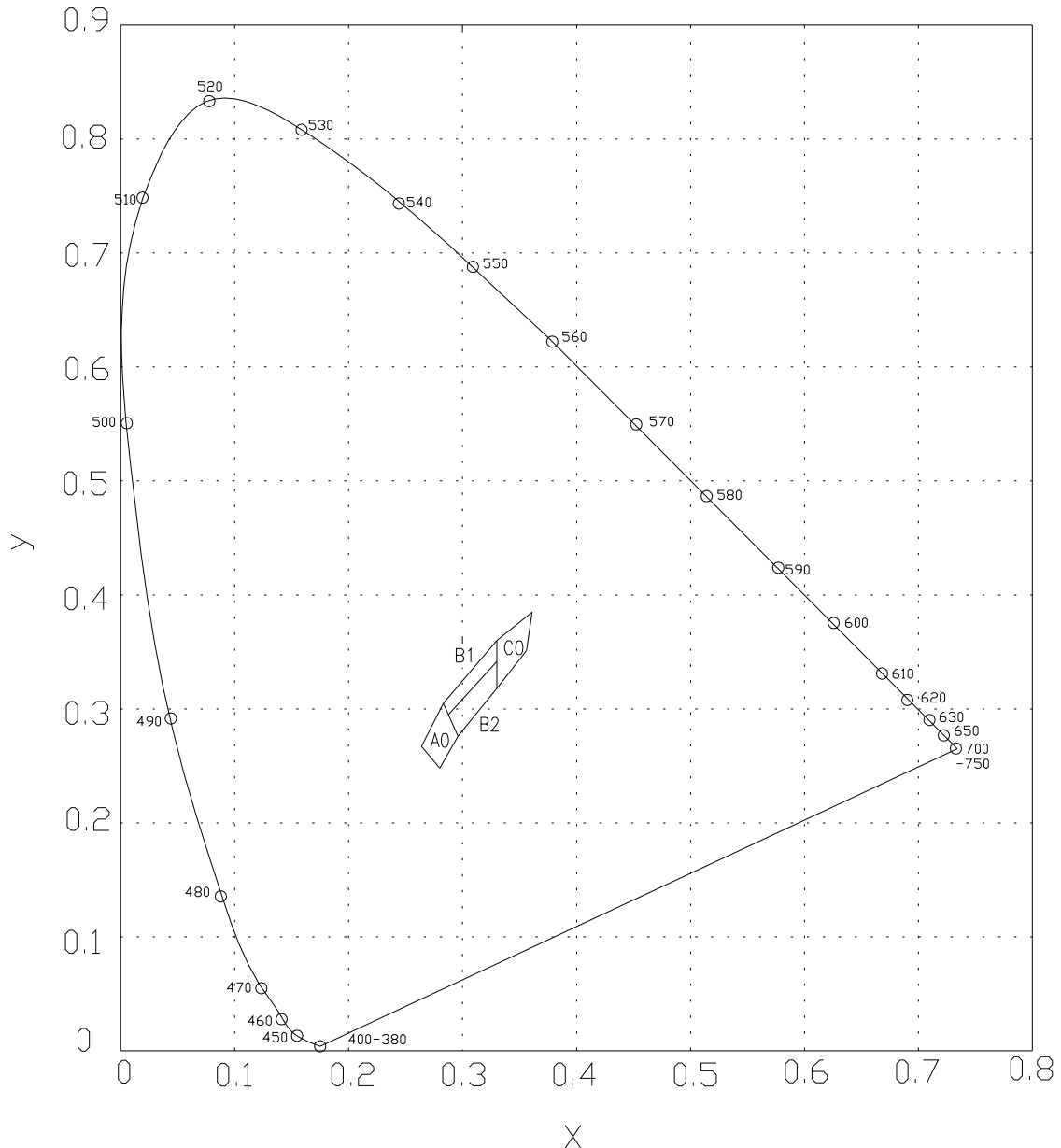

Technical Data Sheet

Top View LEDs

67-23UWC/S400-X9/S612-1/TR8

Typical Electro-Optical Characteristics Curves

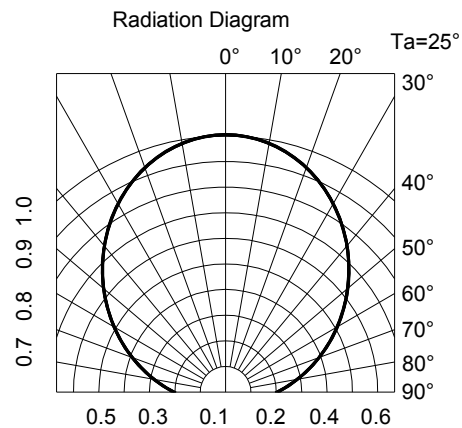
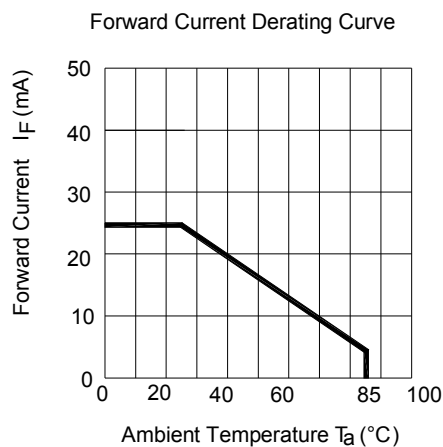
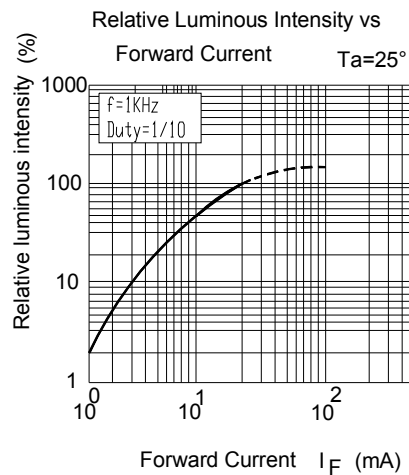
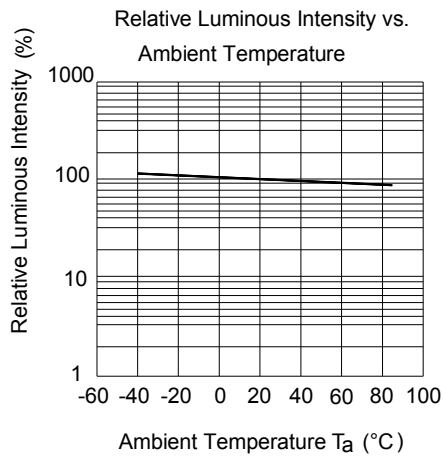
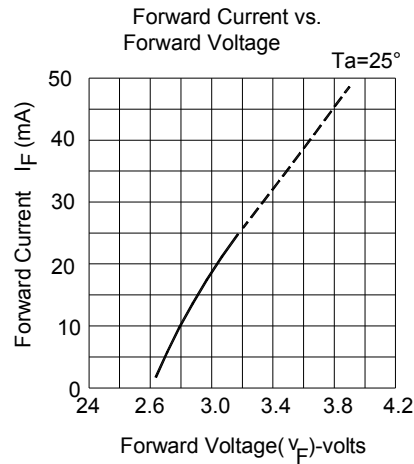
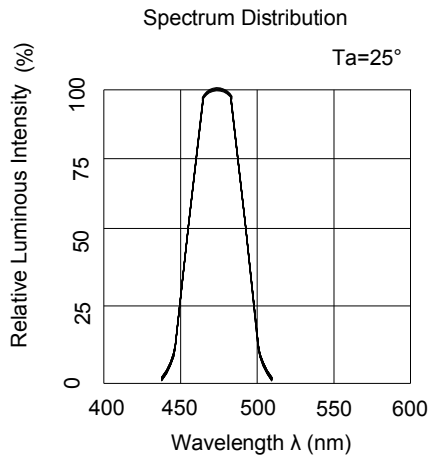

Technical Data Sheet

Top View LEDs

67-23UWC/S400-X9/S612-1/TR8

Label Explanation

CAT: Luminous Intensity Rank
HUE: Chromaticity Coordinates
REF: Forward Voltage Rank

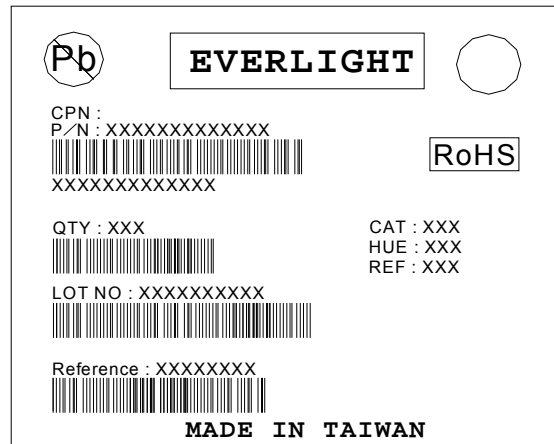

Reel Dimensions

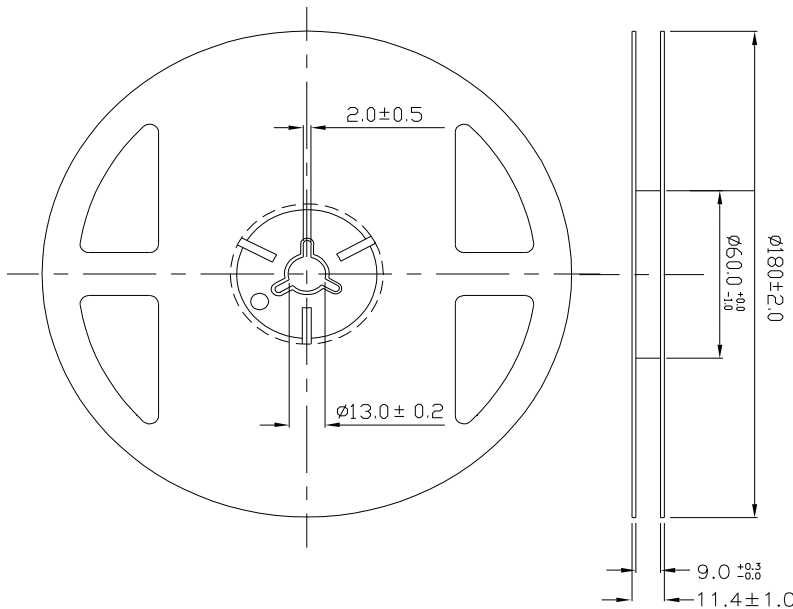

Note: The tolerances unless mentioned is ± 0.1 mm, Unit = mm

Technical Data Sheet

Top View LEDs

67-23UWC/S400-X9/S612-1/TR8

Carrier Tape Dimensions: Loaded Quantity 2000 pcs Per Reel.

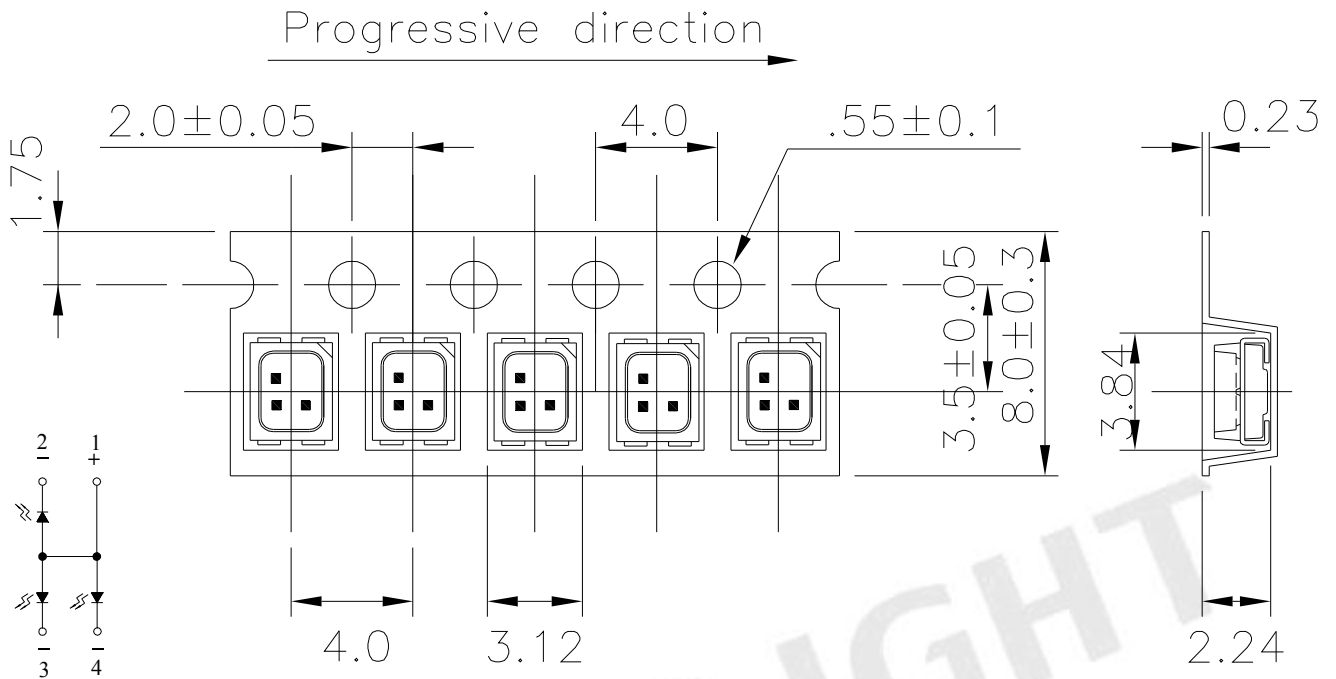

Note : Tolerances unless dimension $\pm 0.1\text{mm}$; Unit = mm

Moisture Resistant Packaging

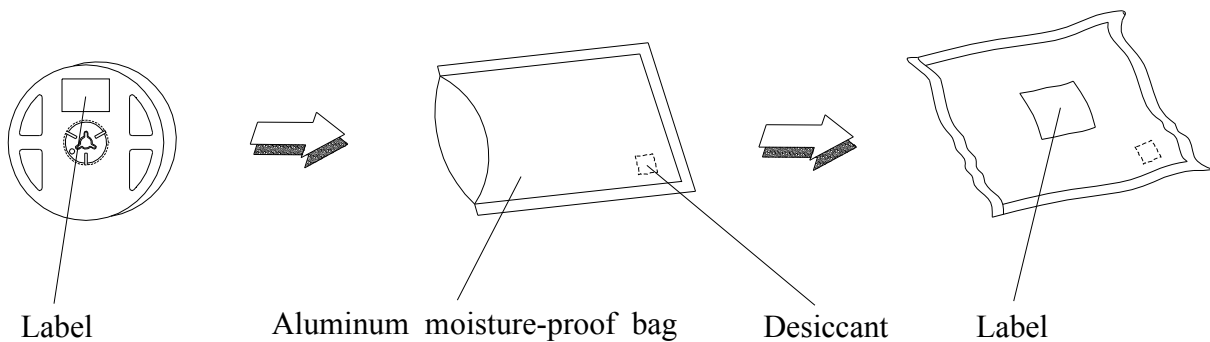

Technical Data Sheet

Top View LEDs

67-23UWC/S400-X9/S612-1/TR8

Reliability Test Items and Conditions

The reliability of products shall be satisfied with items listed below.

Confidence level : 90%

LTPD : 10%

No.	Items	Test Condition	Test Hours/Cycles	Sample Size	Ac/Re
1	Reflow Soldering	Temp. : 260 ±5 Min. 10sec.	6 Min.	22 PCS.	0/1
2	Temperature Cycle	H : +100 15min ∫ 5 min L : -40 15min	300 Cycles	22 PCS.	0/1
3	Thermal Shock	H : +100 5min ∫ 10 sec L : -10 5min	300 Cycles	22 PCS.	0/1
4	High Temperature Storage	Temp. : 100	1000 Hrs.	22 PCS.	0/1
5	Low Temperature Storage	Temp. : -40	1000 Hrs.	22 PCS.	0/1
6	DC Operating Life	I _F = 20 mA	1000 Hrs.	22 PCS.	0/1
7	High Temperature / High Humidity	85 / 85%RH	1000 Hrs.	22 PCS.	0/1

Technical Data Sheet

Top View LEDs

67-23UWC/S400-X9/S612-1/TR8

Precautions for Use

1. Over-current-proof

Customer must apply resistors for protection, otherwise slight voltage shift will cause big current change (Burn out will happen).

2. Storage

2.1 Do not open moisture proof bag before the products are ready to use.

2.2 Before opening the package: The LEDs should be kept at 30 °C or less and 90%RH or less.

2.3 After opening the package: The LED's floor life is 168hours under 30 °C or less and 60% RH or less. If unused LEDs remain, it should be stored in moisture proof packages.

2.4 If the moisture absorbent material (silica gel) has faded away or the LEDs have exceeded the storage time, baking treatment should be performed using the following conditions.

Baking treatment : 60±5 °C for 24 hours.

3. Soldering Condition

3.1 Pb-free solder temperature profile

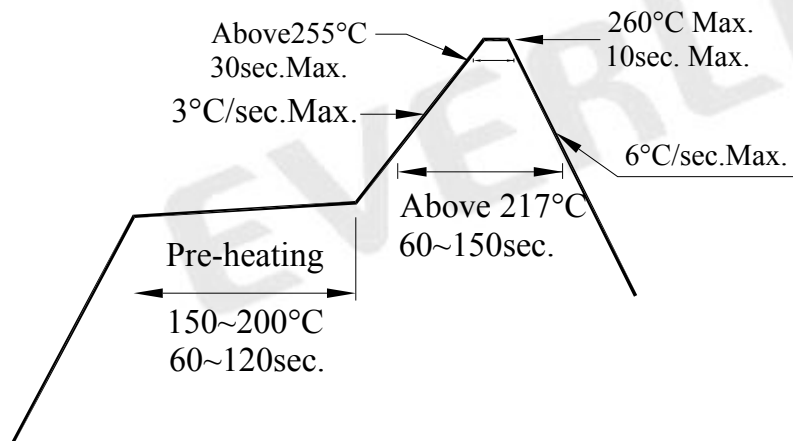

3.2 Reflow soldering should not be done more than two times.

3.3 When soldering, do not put stress on the LEDs during heating.

3.4 After soldering, do not warp the circuit board.

Technical Data Sheet

Top View LEDs

67-23UWC/S400-X9/S612-1/TR8

4. Soldering Iron

Each terminal is to go to the tip of soldering iron temperature less than 350 for 3 seconds within once in less than the soldering iron capacity 25W. Leave two seconds and more intervals, and do soldering of each terminal. Be careful because the damage of the product is often started at the time of the hand solder.

5. Repairing

Repair should not be done after the LEDs have been soldered. When repairing is unavoidable, a double-head soldering iron should be used (as below figure). It should be confirmed beforehand whether the characteristics of the LEDs will or will not be damaged by repairing.

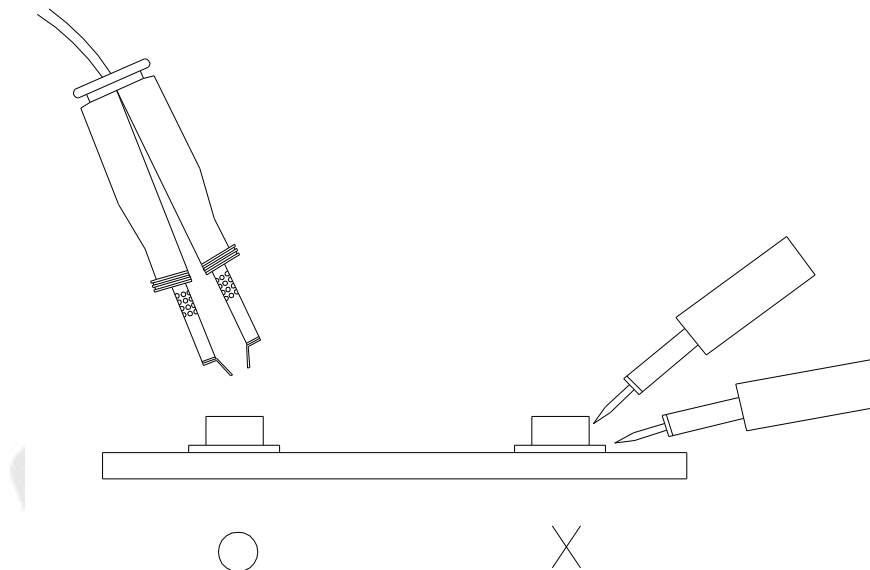

EVERLIGHT ELECTRONICS CO., LTD.
Office: No 25, Lane 76, Sec 3, Chung Yang Rd,
Tucheng, Taipei 236, Taiwan, R.O.C

Tel: 886-2-2267-2000, 2267-9936
Fax: 886-2267-6244, 2267-6189, 2267-6306
<http://www.everlight.com>

X-ON Electronics

Largest Supplier of Electrical and Electronic Components

Click to view similar products for [Standard LEDs - SMD category](#):

Click to view products by [Everlight manufacturer](#):

Other Similar products are found below :

[LTST-C190KYKT](#) [LTST-C19GD2WT](#) [LTST-N683GBEW](#) [LTW-170ZDC](#) [LTW-M140SZS40](#) [598-8110-100F](#) [598-8170-100F](#) [598-8610-202F](#) [AAAF5060QBFSEEZGS](#) [HLMA-QG00-S0021](#) [ALMD-LB36-SV002](#) [APT1608QGW](#) [EAST2012YA0](#) [EASV1803BA0](#) [LG M67K-H1J2-24-0-2-R18-Z](#) [SML-512VWT86A](#) [SML-LX0606SISUGC/A](#) [SML-LXL1307SRC-TR](#) [SML-LXR851SIUPGUBC](#) [LT1ED53A](#) [AM27ZGC03](#) [APB3025SGNC](#) [APFA3010SURKCGKQBDC](#) [APHK1608VGCA](#) [APT2012QGW](#) [CLX6D-FKB-CN1R1H1BB7D3D3](#) [LTST-008BGEW](#) [LTST-C250KGKT](#) [LTW-010DCG](#) [LTW-020ZDCG](#) [LTW-21TS5](#) [LTW-220DS5](#) [598-8330-117F](#) [SML-LX0402IC-TR](#) [CMDA20AYAA7D1S](#) [CMDA16AYDR7A1X](#) [91-21SYGD/S530-E2/TR7](#) [HSMQ-C177](#) [598-8040-100F](#) [598-8070-100F](#) [598-8140-100F](#) [598-8610-200F](#) [EAST2012GA0](#) [EAPL3527GA5](#) [SML-LXL1209SYC/ATR](#) [EAST2012RA0](#) [EAST1608RGBAO](#) [CMD91-21VRC/TR7](#) [SML-LXR851SGSIC-TR](#) [SML-512PWT86A](#)