

8 PIN DIP HIGH SPEED 1Mbit/s TRANSISTOR PHOTOCOUPLER 6N135 6N136 EL450x Series

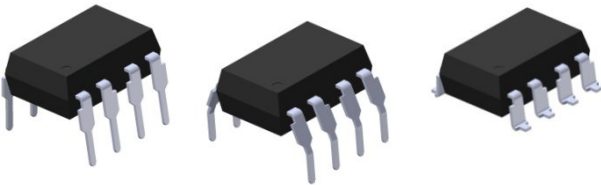

Features

- High speed 1Mbit/s
- High isolation voltage between input and output (Viso=5000 Vrms)
- Guaranteed performance from 0°C to 70°C
- Wide operating temperature range of -55°C to 100°C
- Pb free and RoHS compliant
- UL and cUL approved(No. E214129)
- VDE approved (No. 132249)
- SEMKO approved
- NEMKO approved
- DEMKO approved
- FIMKO approved

Schematic

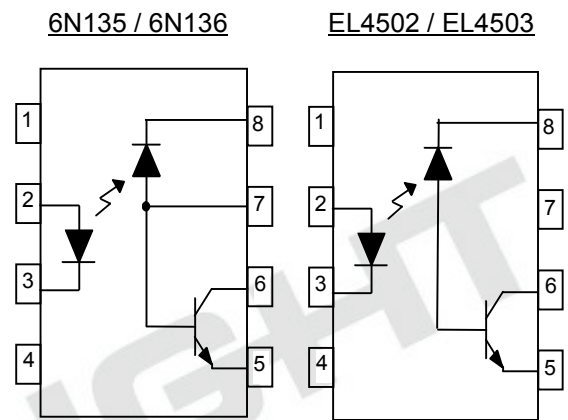

Pin Configuration

1. No Connection
2. Anode
3. Cathode
4. No Connection
5. Gnd
6. Vout
7. V_B
8. V_{CC}

Pin Configuration

1. No Connection
2. Anode
3. Cathode
4. No Connection
5. Gnd
6. Vout
7. No Connection
8. V_{CC}

Description

The 6N135, 6N136, EL4502 and EL4503 devices each consist of an infrared emitting diode, optically coupled to a high speed photo detector transistor. A separate connection for the photodiode bias and output-transistor collector increase the speed by several orders of magnitude over conventional phototransistor couplers by reducing the base-collector capacitance of the input transistor. The devices are packaged in an 8-pin DIP package and available in wide-lead spacing and SMD option

Applications

- Line receivers
- Telecommunication equipments
- Power transistor isolation in motor drives
- Replacement for low speed phototransistor photo couplers
- Feedback loop in switch-mode power supplies
- Home appliances
- High speed logic ground isolation

Absolute Maximum Ratings (Ta=25)

Parameter		Symbol	Rating	Unit
Input	Forward current	I_F	25	mA
	Peak forward current (50% duty, 1ms P.W)	I_{FP}	50	mA
	Peak transient current ($\leq 1\mu s$ P.W, 300pps)	I_{Ftrans}	1	A
	Reverse voltage	V_R	5	V
	Power dissipation	P_{IN}	45	mW
	Power dissipation	P_O	100	mW
Output	Emitter-Base reverse voltage	6N135 6N136 V_{EBR}	5	V
	Base current	6N135 6N136 I_B	5	mA
	Average Output current	$I_{O(AVG)}$	8	mA
	Peak Output current	$I_{O(PK)}$	16	mA
	Output voltage	V_O	-0.5 to 20	V
	Supply voltage	V_{CC}	-0.5 to 30	V
	Total Power Dissipation	P_{TOT}	200	mW
Isolation Voltage*1	V_{ISO}	5000	Vrms	
Operating Temperature	T_{OPR}	-55 to 100		
Storage Temperature	T_{STG}	-55 to 125		
Soldering Temperature*2	T_{SOL}	260		

Notes:

*1 AC for 1 minute, R.H.= 40 ~ 60% R.H. In this test, pins 1, 2, 3, 4 are shorted together, and pins 5, 6, 7, 8 are shorted together.

*2 For 10 seconds

Electrical Characteristics (T_A=0 to 70°C unless specified otherwise)

Input

Parameter	Symbol	Min.	Typ.	Max.	Unit	Condition
Forward Voltage	V _F	-	1.45	1.8	V	I _F = 16mA
Reverse Voltage	V _R	5.0	-	-	V	I _R = 10μA
Temperature coefficient of forward voltage	ΔV _F /ΔT _A	-	-1.9	-	mV/°C	I _F = 16mA

Output

Parameter	Symbol	Min	Typ.	Max.	Unit	Condition
Logic High Output Current	I _{OH}	-	0.001	0.5	μA	I _F =0mA, V _O =V _{CC} =5.5V, T _A =25°C
		-	0.01	1		I _F =0mA, V _O =V _{CC} =15V, T _A =25°C
		-	-	50		I _F =0mA, V _O =V _{CC} =15V
Logic Low Supply Current	I _{CCL}	-	140	200	μA	I _F =16mA, V _O =Open, V _{CC} =15V
Logic High Supply Current	I _{CCH}	-	0.01	1	μA	I _F =0mA, V _O =Open, V _{CC} =15V, T _A =25°C
		-	-	2		I _F =0mA, V _O =Open, V _{CC} =15V

Transfer Characteristics (T_A=0 to 70°C unless specified otherwise)

Parameter	Symbol	Min	Typ.	Max.	Unit	Condition	
Current Transfer Ratio	CTR	6N135	7	-	50	%	I _F = 16mA, V _O = 0.4V, V _{CC} =4.5V, T _A =25°C
		6N136 EL4502 EL4503	19	-	50		
		6N135	5	-	-		
		6N136 EL4502 EL4503	15	-	-		
Logic Low Output Voltage	V _{OL}	6N135	-	0.18	0.4	V	I _F = 16mA, I _O = 1.1mA, V _{CC} =4.5V, T _A =25°C
		6N136 EL4502 EL4503	-	0.25	0.4		
		6N135	-	-	0.5		
		6N136 EL4502 EL4503	-	-	0.5		

Switching Characteristics ($T_A=0$ to 70°C unless specified otherwise, $I_F=16\text{mA}$, $V_{CC}=5\text{V}$)

Parameter	Symbol	Min	Typ.	Max.	Unit	Condition	
Propagation Delay Time to Logic Low (Fig.8)	6N135 6N136 EL4502 EL4503	TPHL	-	0.35	1.5	μs	$R_L = 4.1\text{K}\Omega$, $T_A = 25^\circ\text{C}$
			-	-	2.0		$R_L = 4.1\text{K}\Omega$
			-	0.35	0.8		$R_L = 1.9\text{K}\Omega$, $T_A = 25^\circ\text{C}$
			-	-	1.0		$R_L = 1.9\text{K}\Omega$
Propagation Delay Time to Logic High (Fig.8)	6N135 6N136 EL4502 EL4503	TPLH	-	0.5	1.5	μs	$R_L = 4.1\text{K}\Omega$, $T_A = 25^\circ\text{C}$
			-	-	2.0		$R_L = 4.1\text{K}\Omega$
			-	0.3	0.8		$R_L = 1.9\text{K}\Omega$, $T_A = 25^\circ\text{C}$
			-	-	1.0		$R_L = 1.9\text{K}\Omega$
Common Mode Transient Immunity at Logic High (Fig.9) ^{*3}	6N135 6N136 EL4502 EL4503	CM_H	1,000	-	-	$\text{V}/\mu\text{s}$	$I_F = 0\text{mA}$, $V_{CM} = 10\text{Vp-p}$, $R_L = 4.1\text{K}\Omega$, $T_A = 25^\circ\text{C}$
			1,000	-	-		$I_F = 0\text{mA}$, $V_{CM} = 10\text{Vp-p}$, $R_L = 1.9\text{K}\Omega$, $T_A = 25^\circ\text{C}$
			15000	20000	-		$I_F = 0\text{mA}$, $V_{CM} = 1500\text{Vp-p}$, $R_L = 1.9\text{K}\Omega$, $T_A = 25^\circ\text{C}$
Common Mode Transient Immunity at Logic Low (Fig.9) ^{*3}	6N135 6N136 EL4502 EL4503	CM_L	1,000	-	-	$\text{V}/\mu\text{s}$	$I_F = 16\text{mA}$, $V_{CM} = 10\text{Vp-p}$, $R_L = 4.1\text{K}\Omega$, $T_A = 25^\circ\text{C}$
			1,000	-	-		$I_F = 16\text{mA}$, $V_{CM} = 10\text{Vp-p}$, $R_L = 1.9\text{K}\Omega$, $T_A = 25^\circ\text{C}$
			15000	20000	-		$I_F = 16\text{mA}$, $V_{CM} = 1500\text{Vp-p}$, $R_L = 1.9\text{K}\Omega$, $T_A = 25^\circ\text{C}$

* Typical values at $T_a = 25^\circ\text{C}$

Typical Electro-Optical Characteristics Curves

Fig.1 Forward Current vs. Forward Voltage

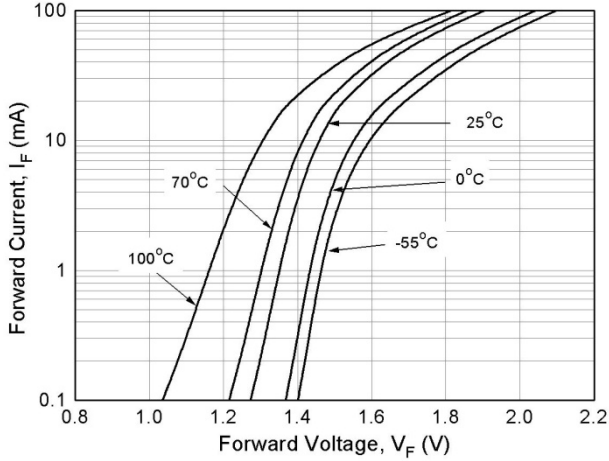

Fig.2 Normalized Current Transfer Ratio vs. Forward Current

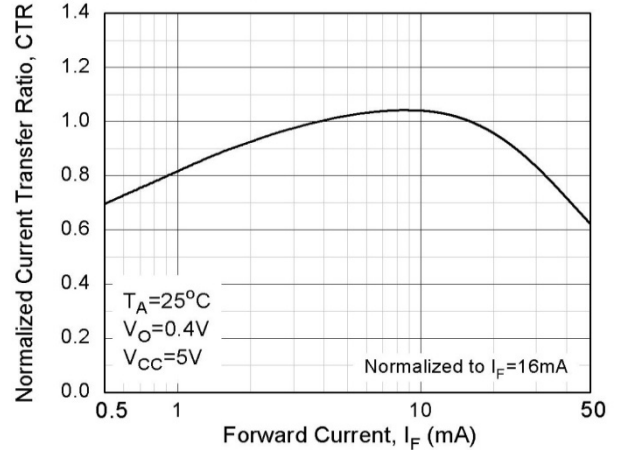

Fig.3 Normalized Current Transfer Ratio vs. Ambient Temperature

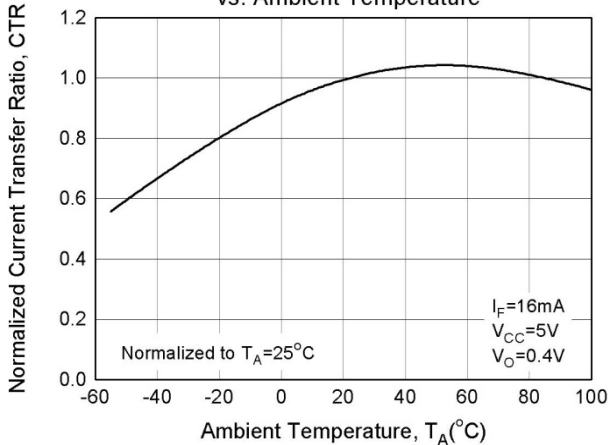

Fig.4 Output Current vs Output Voltage

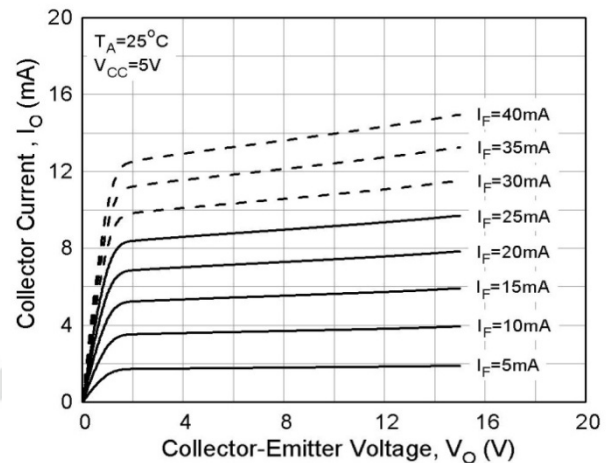

Fig.5 Logic High Output Current vs. Temperature

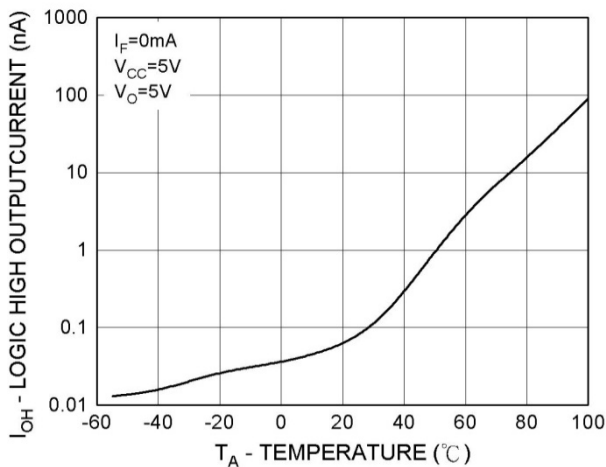

Fig.6 Propagation Delay vs. Load Resistance

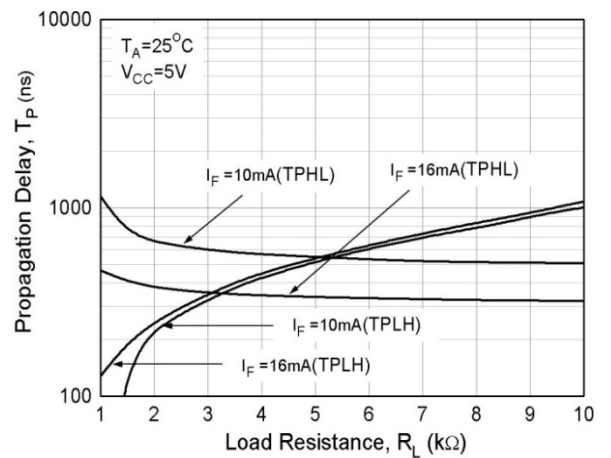

Fig.7 Propagation Delay vs. Temperature

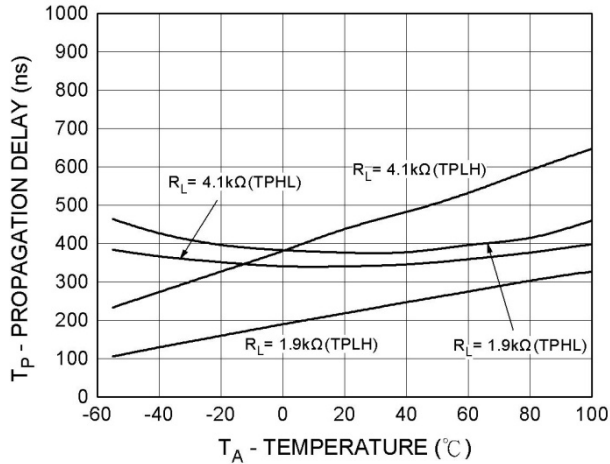

Figure 8 Switching Time Test Circuit & Waveform

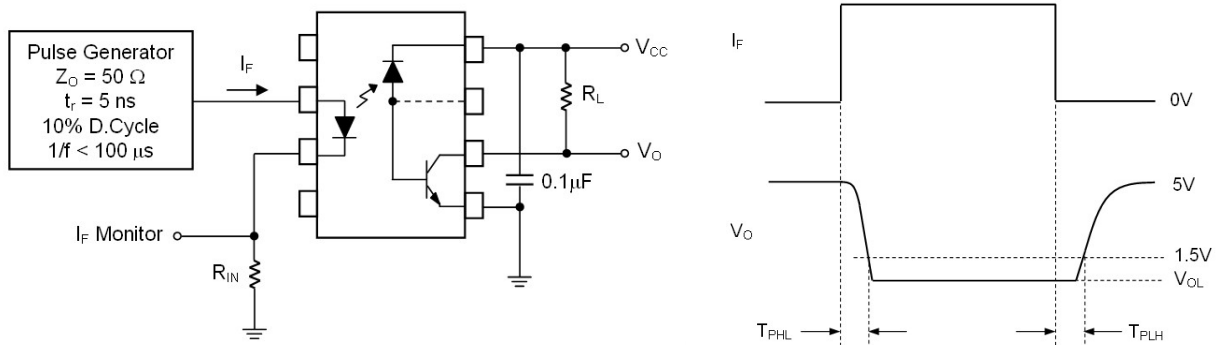
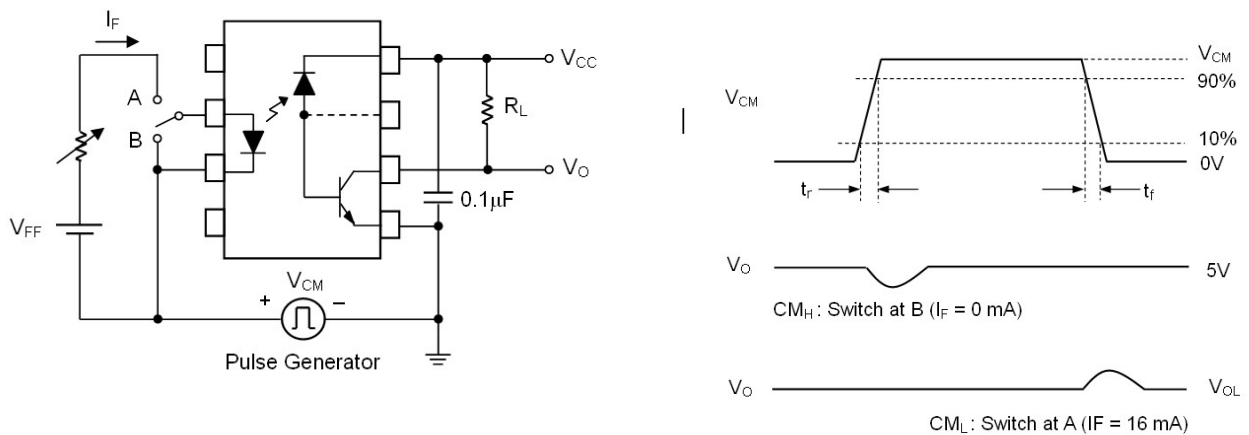

Figure 9 Transient Immunity Test Circuit & Waveform



Note:

*3 Common mode transient immunity in logic high level is the maximum tolerable (positive) dV_{cm}/dt on the leading edge of the common mode pulse signal V_{CM} , to assure that the output will remain in a logic high state (i.e., $V_O > 2.0V$).

Common mode transient immunity in logic low level is the maximum tolerable (negative) dV_{cm}/dt on the trailing edge of the common mode pulse signal, V_{CM} , to assure that the output will remain in a logic low state (i.e., $V_O < 0.8V$).

Order Information

Part Number

6N13XY(Z)-V

or

EL450XY(Z)-V

Note

- X = Part No. (X = 5 or 6) for 6N series; (X=2 or 3) for EL45 series
- Y = Lead form option (S, S1, M or none)
- Z = Tape and reel option (TA, TB or none)
- V = VDE (optional)

Option	Description	Packing quantity
None	Standard DIP-8	45 units per tube
M	Wide lead bend (0.4 inch spacing)	45 units per tube
S (TA)	Surface mount lead form + TA tape & reel option	1000 units per reel
S (TB)	Surface mount lead form + TB tape & reel option	1000 units per reel
S1 (TA)	Surface mount lead form (low profile) + TA tape & reel option	1000 units per reel
S1 (TB)	Surface mount lead form (low profile) + TB tape & reel option	1000 units per reel

Package Dimension
(Dimensions in mm)

Standard DIP Type

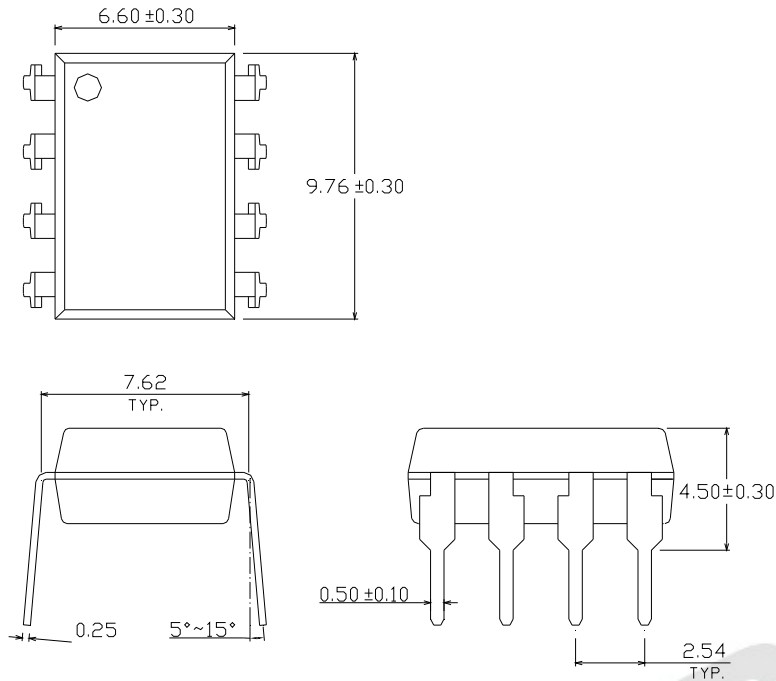

Option M Type

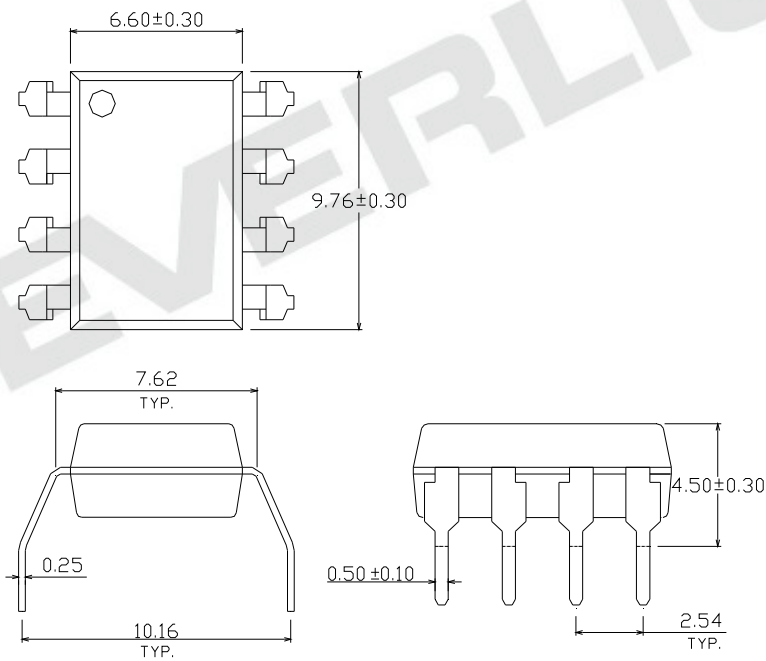

Option S Type

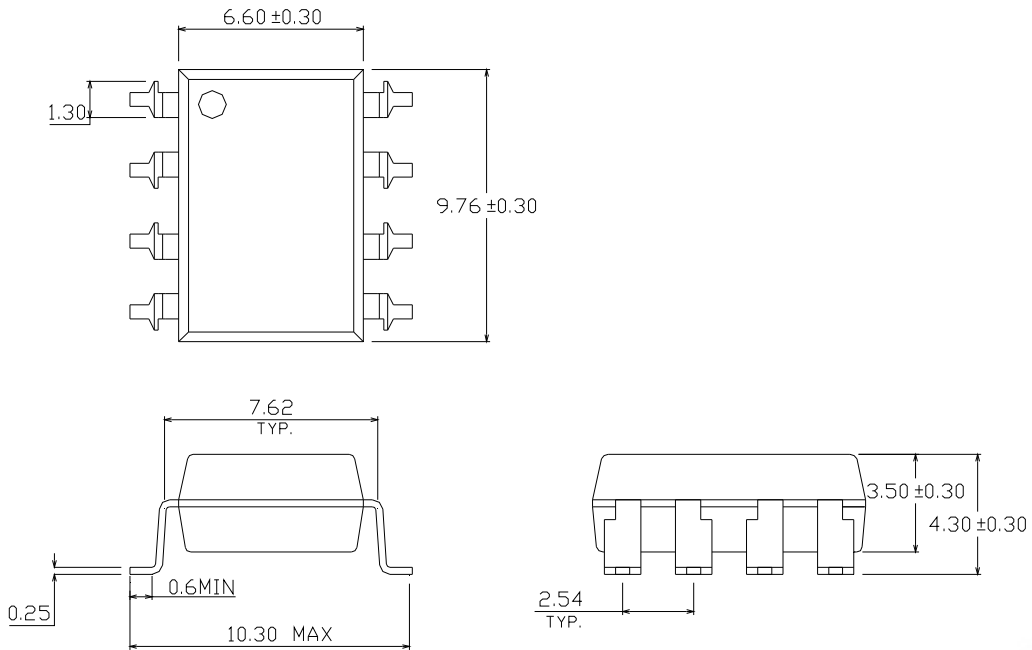

Option S1 Type

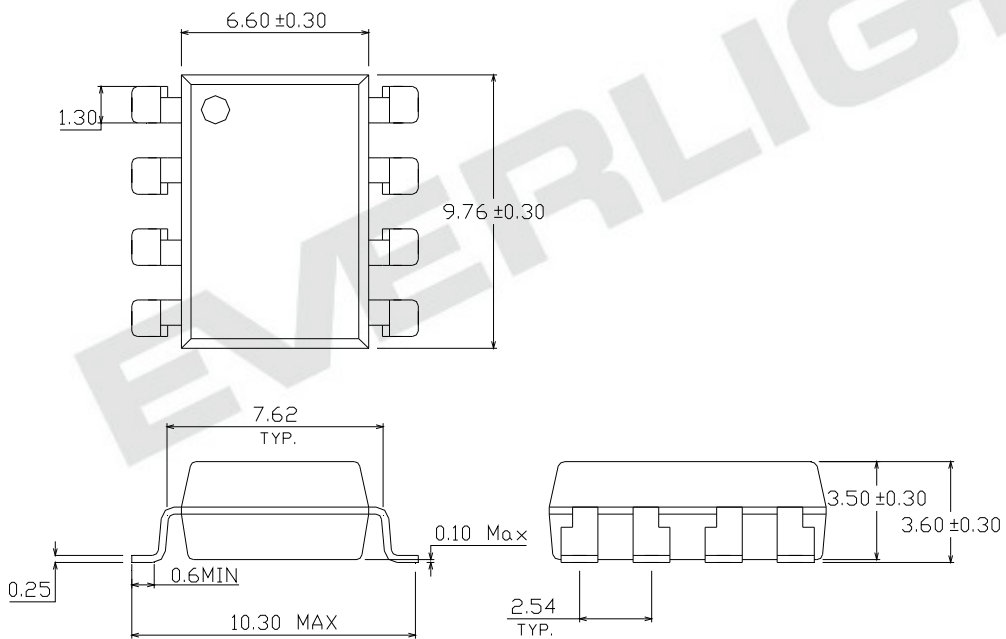

Recommended pad layout for surface mount leadform

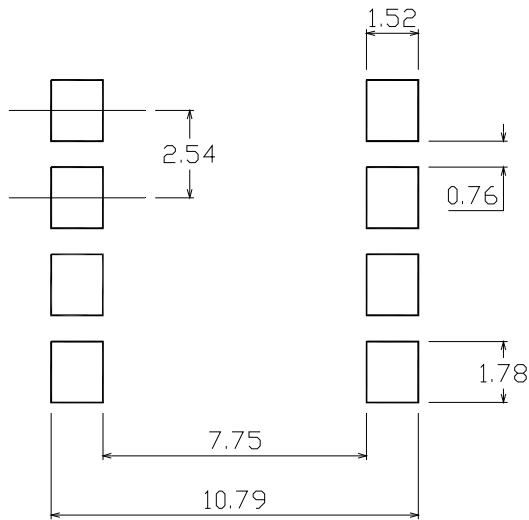

Device Marking

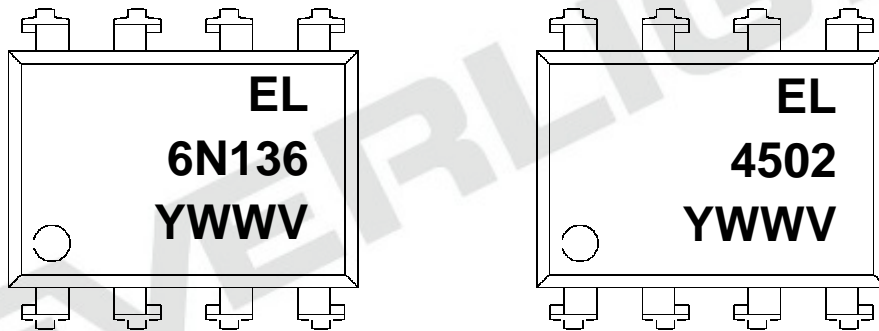

Notes

- EL denotes EVERLIGHT
- 4502 denotes Device Number
- 6N136 denotes Device Number
- Y denotes 1 digit Year code
- WW denotes 2 digit Week code
- V denotes VDE (optional)

Tape & Reel Packing Specifications

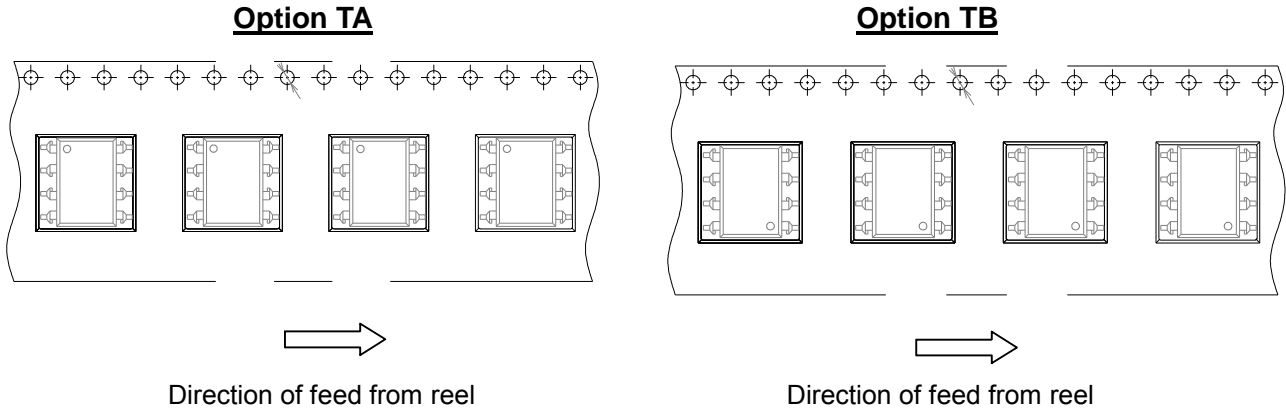

Tape dimensions

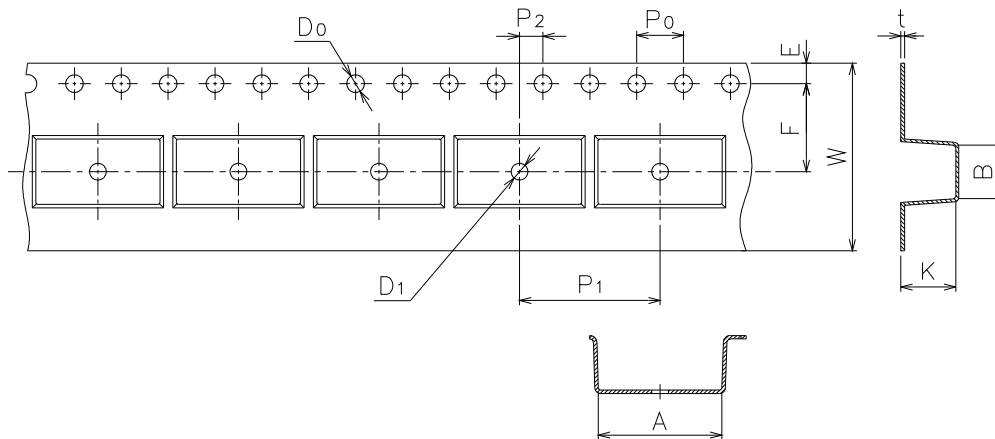

Dimension No.	A	B	Do	D1	E	F
Dimension(mm)	10.4±0.1	10.0±0.1	1.5+0.1/-0	1.5±0.25/-0	1.75±0.1	7.5±0.1
Dimension No.	Po	P1	P2	t	W	K
Dimension(mm)	4.0±0.1	12.0±0.1	2.0±0.05	0.4±0.05	16.0±0.3/	4.5±0.1

Precautions for Use

1. Soldering Condition

1.1 (A) Maximum Body Case Temperature Profile for evaluation of Reflow Profile

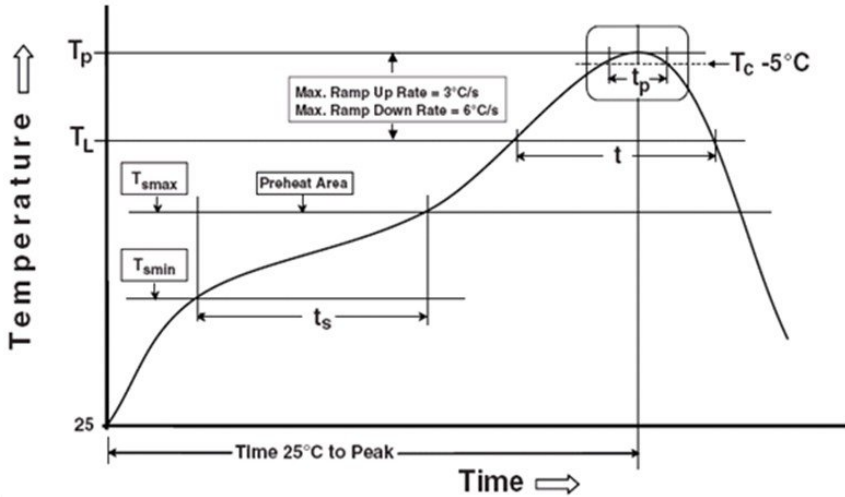

Note:

Reference: IPC/JEDEC J-STD-020D

Preheat

Temperature min (T_{smin})	150 °C
Temperature max (T_{smax})	200°C
Time (T_{smin} to T_{smax}) (t_s)	60-120 seconds
Average ramp-up rate (T_{smax} to T_p)	3 °C/second max

Other

Liquidus Temperature (T_L)	217 °C
Time above Liquidus Temperature (t_L)	60-100 sec
Peak Temperature (T_P)	260°C
Time within 5 °C of Actual Peak Temperature: $T_P - 5^\circ\text{C}$	30 s
Ramp- Down Rate from Peak Temperature	6°C /second max.
Time 25°C to peak temperature	8 minutes max.
Reflow times	3 times

DISCLAIMER

1. Above specification may be changed without notice. EVERLIGHT will reserve authority on material change for above specification.
2. When using this product, please observe the absolute maximum ratings and the instructions for using outlined in these specification sheets. EVERLIGHT assumes no responsibility for any damage resulting from use of the product which does not comply with the absolute maximum ratings and the instructions included in these specification sheets.
3. These specification sheets include materials protected under copyright of EVERLIGHT corporation. Please don't reproduce or cause anyone to reproduce them without EVERLIGHT's consent.

EVERLIGHT

X-ON Electronics

Largest Supplier of Electrical and Electronic Components

Click to view similar products for [High Speed Optocouplers](#) category:

Click to view products by [Everlight](#) manufacturer:

Other Similar products are found below :

[HCPL-2201-300](#) [TLP558\(F\)](#) [JAN4N24](#) [610737H](#) [HCPL2630M](#) [HCPL2731SM](#) [HCPL2630SM](#) [PS9817A-1-F3-AX](#) [TLP2766A\(E](#)
[TLP2766A\(LF4,E](#) [EL816S2\(C\)\(TU\)-F](#) [TLP281-4](#) [TLP2363\(V4-TPR,E](#) [PS9121-F3-AX](#) [PS9123-F3-AX](#) [HCPL2531S](#) [HCPL2631SD](#) [HCPL-](#)
[4661-500E](#) [TLP118\(TPL,E\)](#) [TLP2309\(E\(T](#) [TLP521-2XGB](#) [TLP621-2XGB](#) [4N46-300E](#) [JANTXV4N24U](#) [SFH6318T](#) [6N135-300E](#) [TIL198](#)
[TLP2309\(TPL,E\)](#) [TLP2355\(TPL,E](#) [TLP521-4GR](#) [TLP521-4XGB](#) [TLP621-4X](#) [TLP621XSM](#) [IS181GR](#) [ICPL2631](#) [ICPL2630](#) [ICPL2601](#)
[TLP714\(F\)](#) [TLP754\(F\)](#) [FOD260LSDV](#) [ACPL-M21L-500E](#) [ACPL-064L-500E](#) [PS2501-1XSM](#) [PS2505-1](#) [PS2561L2-1-F3-A](#) [PS2913-1-F3-](#)
[AX](#) [PS9821-2-F3-AX](#) [FOD0721R2](#) [FODM8061R2V](#) [6N135SDM](#)