

RGB Color Light Sensor Surface - Mount

CLS15-22C/L213R/TR8

CLS15-22C/L213G/TR8

CLS15-22C/L213B/TR8

Features

- Surface-mount plastic package
- High sensitivity for Red, Green, and Blue light source
CLS15-22C/L213R/TR8 ($\lambda_p= 620\text{nm}$, Red)
CLS15-22C/L213G/TR8 ($\lambda_p= 550\text{nm}$, Green)
CLS15-22C/L213B/TR8 ($\lambda_p= 470\text{nm}$, Blue)
- Good stable analog output with temperature shift
- Size: 3.2mm (L)*2.7mm (W)*1.1mm (H)
- Operating temperature performance, -40°C to 85°C
- Active area: 1.8 mm^2
- RoHS compliant and Pb free package

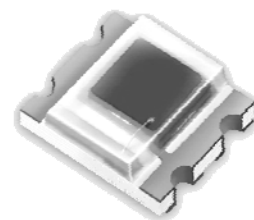

Description

CLS15-22C/L213/TR8 series color sensor device is one channel Si photodiode sensitivity to Red, Green and Blue region spectrum in miniature SMD package. Everlight color sensor series product is the good effective and low cost solution to white color balance, color detection and color management applications.

Applications

- Color adjustment for LED back light system
- Color adjustment for LED projector
- Color detection
- White balance adjustment
- Consumer and mobile appliances

Package Dimensions

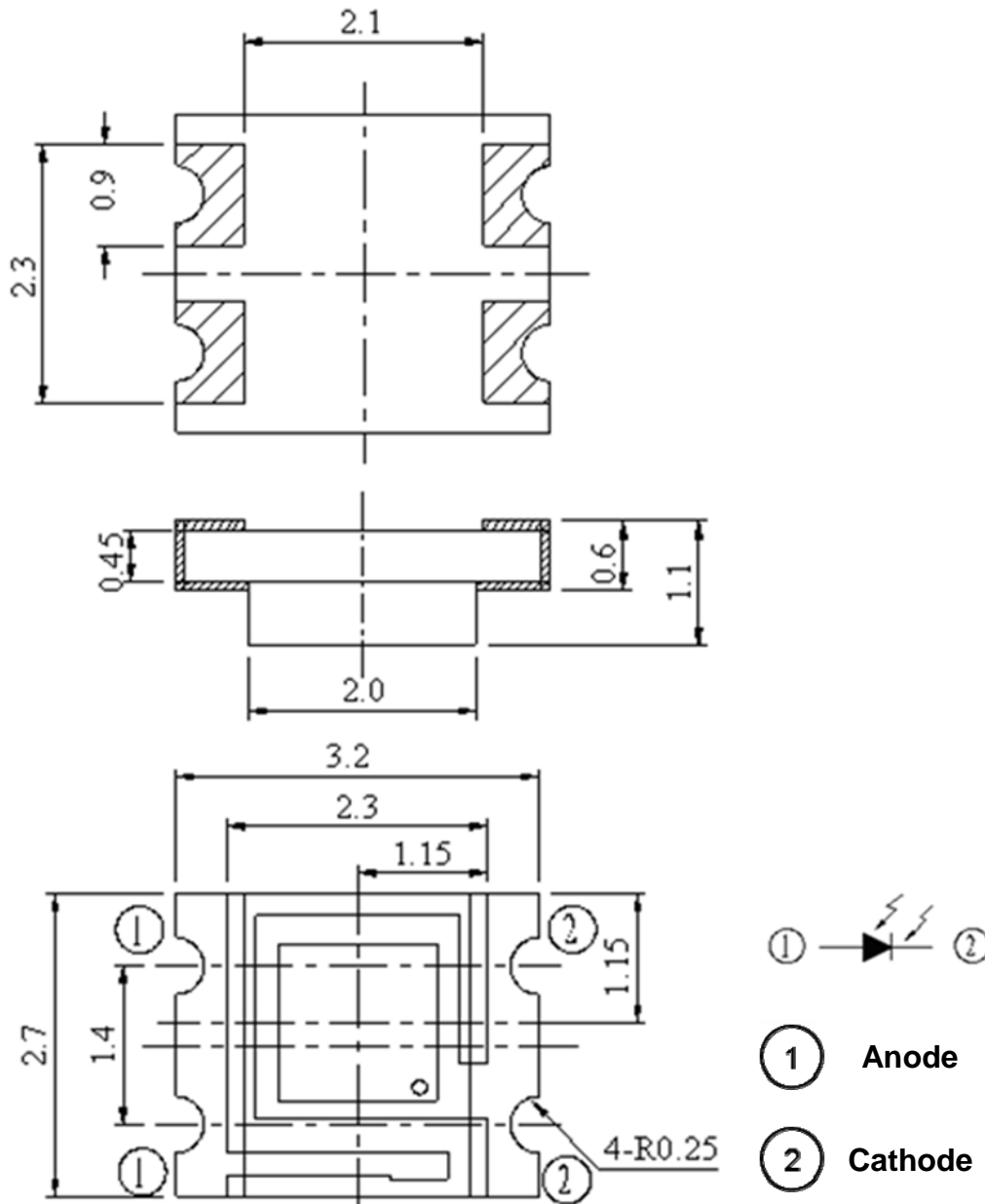

Unit : mm
Tolerances : ± 0.1 mm

Absolute Maximum Ratings

| Parameter | Symbol | Condition | Rating | Units |
|--|-----------|------------------|-----------|-------|
| Reverse Breakdown Voltage | V_{BR} | $I_R = 100\mu A$ | 35 | V |
| Forward Voltage | V_F | $I_F = 10mA$ | 0.5~1.3 | V |
| Operating Temperature | T_{opr} | -- | -40 ~ +85 | °C |
| Storage Temperature | T_{stg} | -- | -40 ~ +85 | °C |
| Soldering Temperature [Note] | T_{sol} | -- | 260 | °C |

Note: Soldering time ≤ 5 seconds

Electrical and Optical Characteristics ($T_a=25^\circ C$)

Red Color Sensor : CLS15-22C/L213R/TR8

| Parameter | Symbol | Condition | MIN. | TYP. | MAX. | Unit |
|-----------------------------|-------------|--|------|-------|------|---------|
| Peak Sensitivity Wavelength | λ_P | -- | -- | 620 | -- | nm |
| Short-Circuit Current | I_{SC} | $E_v=100Lux$ $V_R=0V$ [Note] | -- | 0.086 | -- | μA |
| Light Current | I_{L1} | $E_v=100Lux$ $V_R=5V$ [Note] | -- | 0.091 | -- | μA |
| | I_{L2} | $E_v=1000Lux$ $V_R=5V$ [Note] | -- | 0.83 | -- | μA |
| Reverse Dark Current | I_D | $E_v=0$ $V_R = 10 V$ | -- | 2 | 10 | nA |
| Total Capacitance | C_t | $E_e=0mW /cm^2$ $f=1MHz$ $V_R=5V$ | -- | 12 | -- | pF |

Note: White Fluorescent light (Color Temperature = 6500K) is used as light source.

Green Color Sensor: CLS15-22C/L213G/TR8

| Parameter | Symbol | Condition | MIN. | TYP. | MAX. | Unit |
|-----------------------------|----------------|---|------|-------|------|------|
| Peak Sensitivity Wavelength | λ_P | -- | -- | 550 | -- | nm |
| Short-Circuit Current | I_{SC} | Ev=100Lux V _R =0V [Note] | -- | 0.075 | -- | μA |
| Light Current | I_{L1} | Ev=100Lux V _R =5V [Note] | -- | 0.082 | -- | μA |
| | I_{L2} | Ev=1000Lux V _R =5V [Note] | -- | 0.72 | -- | μA |
| Reverse Dark Current | I_D | Ev=0 Lux V _R = 10 V | -- | 2 | 10 | nA |
| Total Capacitance | C _t | Ee=0mW /cm ² f=1MHz V _R =5V | -- | 12 | -- | pF |

Note: White Fluorescent light (Color Temperature = 6500K) is used as light source.

Blue Color Sensor: CLS15-22C/L213B/TR8

| Parameter | Symbol | Condition | MIN. | TYP. | MAX. | Unit |
|-----------------------------|----------------|---|------|-------|------|------|
| Peak Sensitivity Wavelength | λ_P | -- | -- | 470 | -- | nm |
| Short-Circuit Current | I_{SC} | Ev=100Lux V _R =0V [Note] | -- | 0.042 | -- | μA |
| Light Current | I_{L1} | Ev=100Lux V _R =5V [Note] | -- | 0.046 | -- | μA |
| | I_{L2} | Ev=1000Lux V _R =5V [Note] | -- | 0.39 | -- | μA |
| Reverse Dark Current | I_D | Ev=0 Lux V _R = 10 V | -- | 2 | 10 | nA |
| Total Capacitance | C _t | Ee=0mW /cm ² f=1MHz V _R =5V | --- | 12 | --- | pF |

Note: White Fluorescent light (Color Temperature = 6500K) is used as light source.

Typical Electro-Optical Characteristics Curves

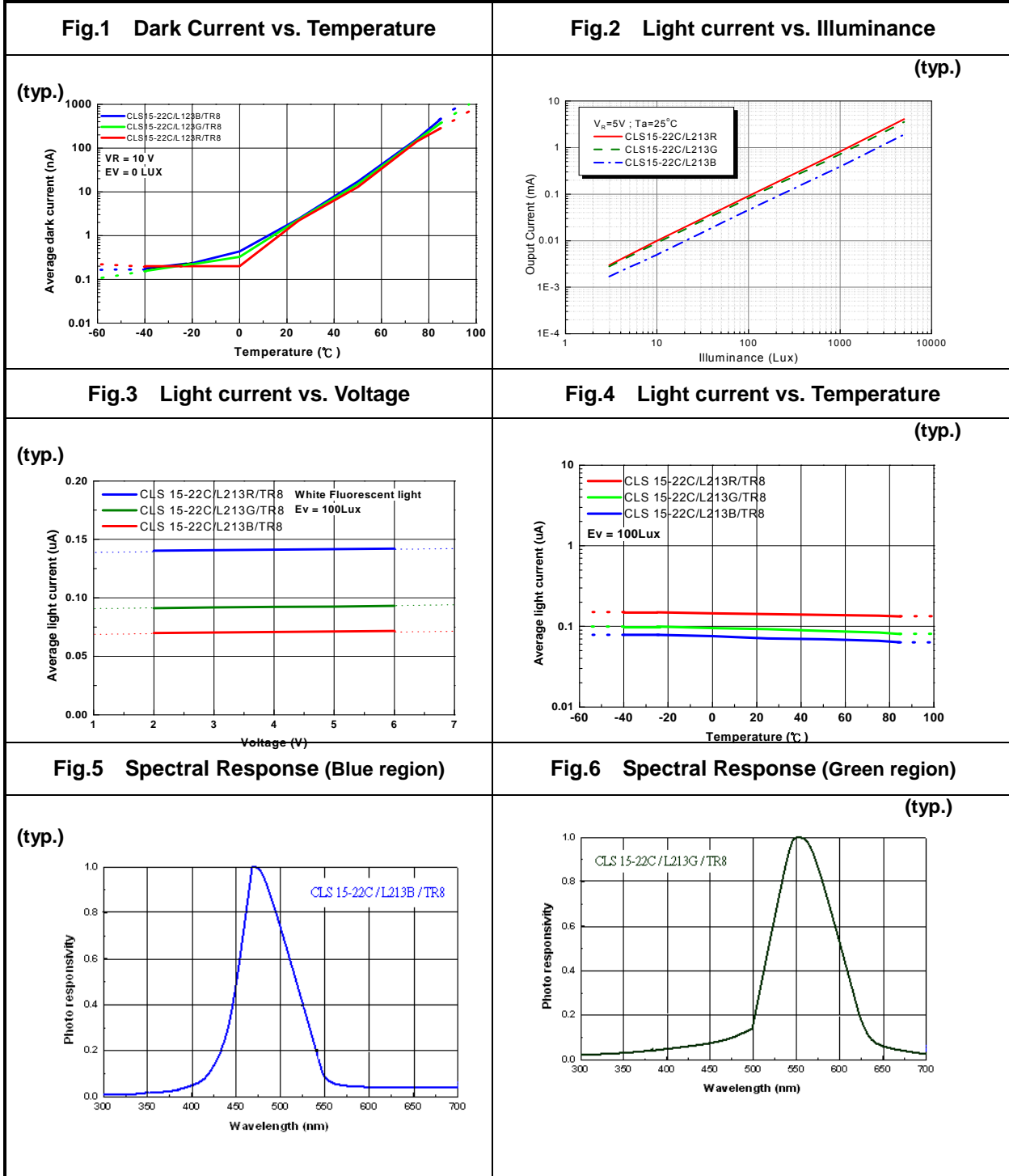
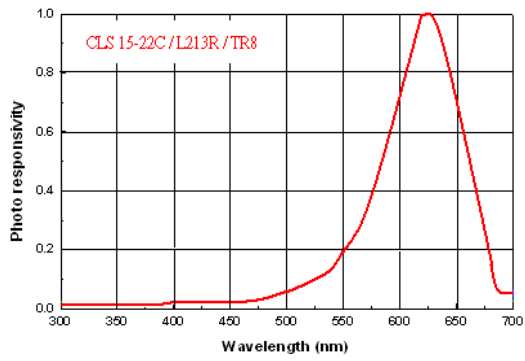

Fig.7 Spectral Response (Red region)

(typ.)



Recommended method of storage

Reflow Terms: JEDEC Level 4 Specification

Dry box storage is recommended as soon as the aluminum bag has been opened prevent moisture absorption. The following conditions should be observed, if dry boxes are not available:

- Storage temperature 10°C to 30°C
- Storage humidity $\leq 60\%RH$ max

After more than 72 hours under these conditions moisture content will be too high for Reflow soldering. In case of moisture absorption, the devices will recover to former condition by drying under the following condition:

- 192 hours at 40°C+5°C/-0°C and 5%RH (dry air / nitrogen), or
- 96 hours at 60°C+5°C and < 5%RH for all device containers, or
- 24 hours at 125°C+5°C not suitable for reel or tubes

ESD Precaution:

Proper storage and handling procedures should be followed to prevent ESD damage to the devices especially when they are removed from the Anti-static bag. Electro-Static Sensitive Devices warning labels are on the packing.

Recommended Solder Profile

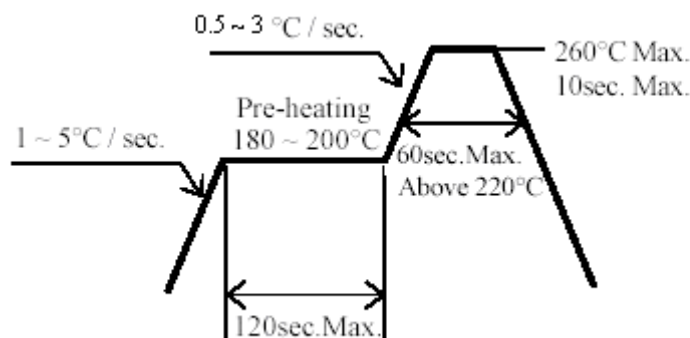

Notice:

- (1) Reflow soldering should not be done more than two times.
- (2) When soldering, do not put stress on the devices during heating.
- (3) After soldering, do not warp the circuit board.

Soldering Iron

Each terminal is to go to the tip of soldering iron temperature less than 350°C for 3 seconds within once in less than the soldering iron capacity 25W. Leave two seconds and more intervals, and do soldering of each terminal. Be careful because the damage of the product is often started at the time of the hand solder.

Repairing

Repair should not be done after the device have been soldered. When repairing is unavoidable, a double-head soldering iron should be used (as below figure). It should be confirmed beforehand whether the characteristics of the device will or will not be damaged by repairing.

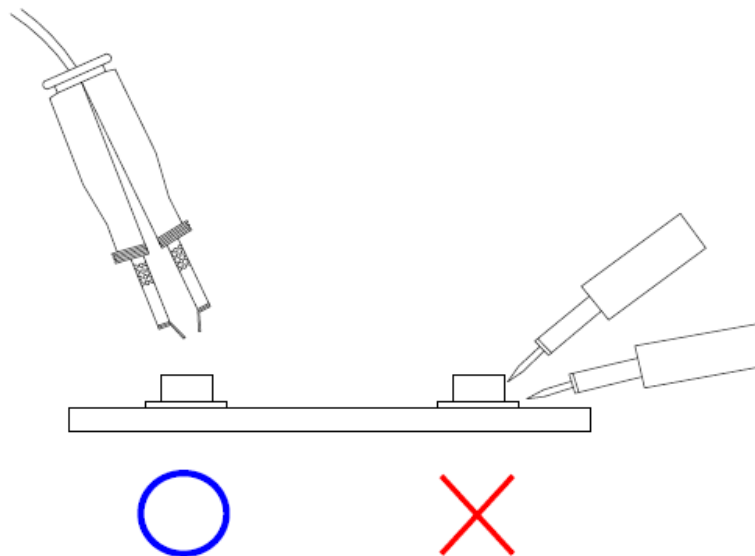

Packing Quantity Specification

3000 PCS/ 1 Reel

Label Format



CPN: Customer's Production Number

P/N : Production Number

QTY: Packing Quantity

CAT: Ranks

HUE: Peak Wavelength

REF: Reference

LOT No: Lot Number

MADE IN TAIWAN: Production Place

Reel Dimensions

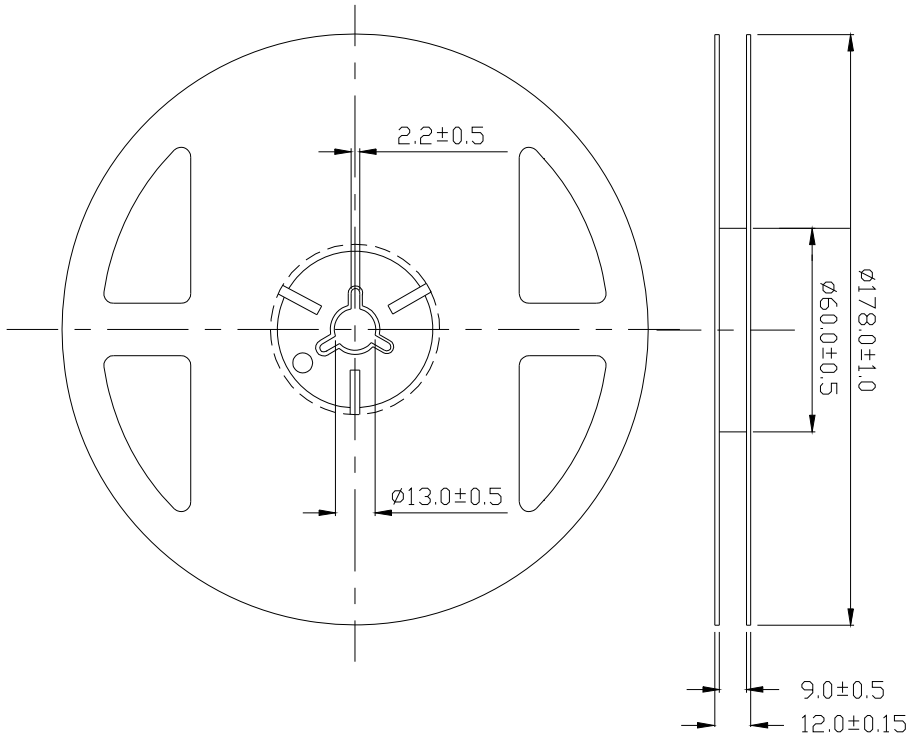

Unit: mm
 Tolerance: ± 0.1 mm

Tape Dimensions

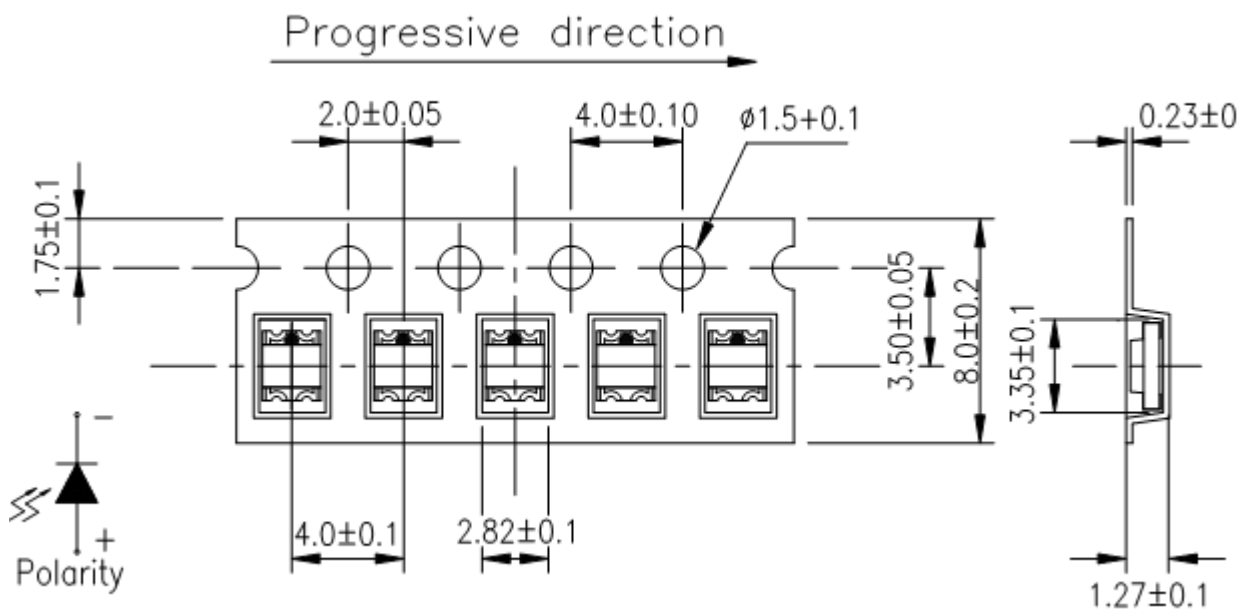

Unit: mm
 Tolerance: ± 0.1 mm

Moisture Resistant Packaging

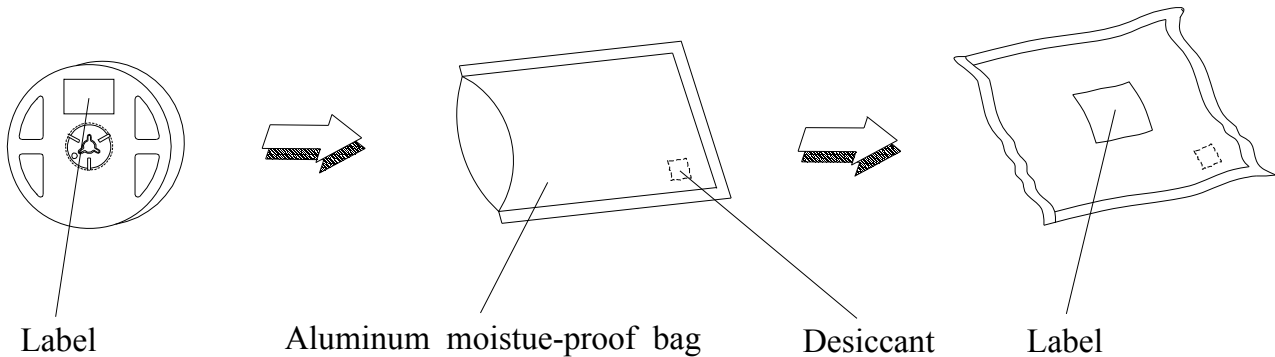

Note:

1. Above specification may be changed without notice. EVERLIGHT will reserve authority on material change for above specification.
2. When using this product, please observe the absolute maximum ratings and the instructions for using outlined in these specification sheets. EVERLIGHT assumes no responsibility for any damage resulting from use of the product which does not comply with the absolute maximum ratings and the instructions included in these specification sheets.
3. These specification sheets include materials protected under copyright of EVERLIGHT corporation. Please don't reproduce or cause anyone to reproduce them without EVERLIGHT's consent.

X-ON Electronics

Largest Supplier of Electrical and Electronic Components

Click to view similar products for [Ambient Light Sensors](#) category:

Click to view products by [Everlight](#) manufacturer:

Other Similar products are found below :

[IS31SE5000-UTLS2-TR](#) [0805-PTSM D021](#) [ALS-PT19-315C/L177/TR8](#) [BH1680FVC-TR](#) [SI1132-A10-GM](#) [APS3227SP1C-P22](#) [ALS-PDIC144-6C/L378](#) [4681](#) [AS7211-BLGM](#) [AS7211-BLGT](#) [AS7220-BLGM](#) [AS7221-BLGM](#) [AS7263-BLGM](#) [AS72652-BLGT](#) [AS7341-DLGM](#) [AS7341-DLGT](#) [TMD27253M](#) [TMD27504](#) [TMD37024VCM](#) [TMD37193M](#) [TMD37253M](#) [TSL25403M](#) [TSL27403M](#) [APDS-9007-020](#) [DY-FPD204-6B/L3](#) [DY-FPD333-3B/L3](#) [DY-FPD333B-A5](#) [DY-FPD4134C-A3](#) [DY-PD204-6B](#) [DY-PD234-6B](#) [DY-PD333B-A5](#) [DY-PD673B-A2](#) [CLS15-22C/L213G/TR8](#) [CLS15-22C/L213R/TR8](#) [HLPT5I850HP25](#) [LTR-303ALS-01](#) [LTR-329ALS-01](#) [LTR-308ALS-01](#) [NJL7502L](#) [LV0111CF-TLM-H](#) [SFH 3711](#) [BH1603FVC-TR](#) [BH1620FVC-TR](#) [BH1621FVC-TR](#) [BH1710FVC-TR](#) [BH1715FVC-TR](#) [BH1721FVC-TR](#) [BH1730FVC-TR](#) [BH1749NUC-E2](#) [BH1750FVI-TR](#)