

### Technical Data Sheet 1206 Package Phototransistor EAPST3215A1

#### Features

- Fast response time
- High photo sensitivity
- Small junction capacitance
- Package in 8mm tape on 7" diameter reels.
- Pb free
- The product itself will remain within RoHS compliant version.

#### Description

• EAPST3215A1 is a phototransistor in miniature SMD package which is molded in a black plastic with flat top view lens. The device is spectrally matched to infrared emitting diode.

#### Applications

- Miniature switch
- Counters and sorter
- Position sensor
- Infrared applied system

#### Device Selection Guide

Device No.	Chip Material	Lens Color
EAPST3215A1	Silicon	Black

**Package Dimensions**

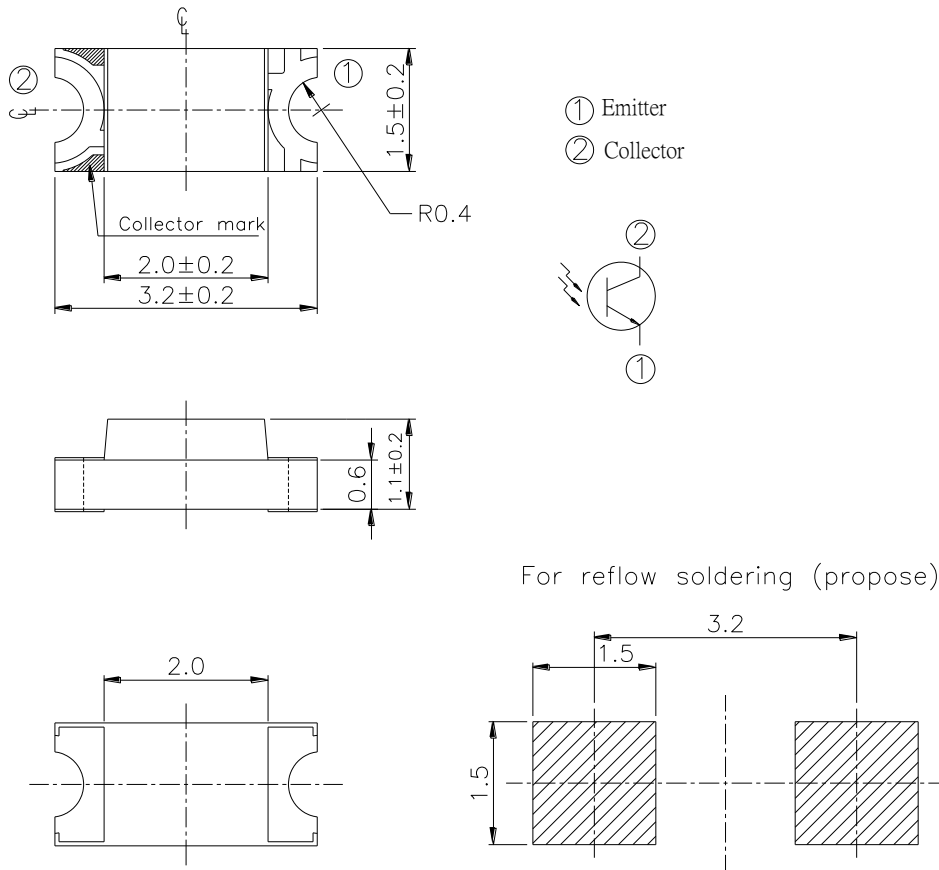

For reflow soldering (propose)

- Notes: 1.All dimensions are in millimeters
- 2.Tolerances unless dimensions  $\pm 0.1$ mm

**Absolute Maximum Ratings (Ta=25°C)**

Parameter	Symbol	Rating	Unit
Collector-Emitter Voltage	$V_{CEO}$	30	V
Emitter-Collector-Voltage	$V_{ECO}$	5	V
Operating Temperature	$T_{opr}$	-25 ~ +85	°C
Storage Temperature	$T_{stg}$	-40 ~ +85	°C
Soldering Temperature *1	$T_{sol}$	260	°C
Power Dissipation at(or below) 25°C Free Air Temperature	$P_c$	75	mW

Notes: \*1: Soldering time  $\leq 5$  seconds.

**Electro-Optical Characteristics (Ta=25°C)**

Parameter	Symbol	Min.	Typ.	Max.	Unit	Condition
Rang Of Spectral Bandwidth	$\lambda_{0.5}$	730	---	1100	nm	10% of $\lambda_p$
Wavelength Of Peak Sensitivity	$\lambda_p$	---	940	---	nm	---
Collector-Emitter Breakdown Voltage	$BV_{CEO}$	30	---	---	V	$I_C=100\mu A$ $E_e=0mW/cm^2$
Emitter-Collector Breakdown Voltage	$BV_{ECO}$	5	---	---	V	$I_E=100\mu A$ $E_e=0mW/cm^2$
Collector-Emitter Saturation Voltage	$V_{CE(sat)}$	---	---	0.4	V	$I_C=2mA$ $E_e=1m W/cm^2$
Collector Dark Current	$I_{CEO}$	---	---	100	nA	$V_{CE}=20V$ $E_e=0mW/cm^2$
On State Collector Current	$I_{C(ON)}$	0.1	0.3		mA	$V_{CE}=5V$ $E_e=1mW /cm^2$ $\lambda_p=940nm$
Rise Time	$t_r$	---	15	---	$\mu S$	$V_{CE}=5V$ $I_C=1mA$ $R_L=1000\Omega$
Fall Time	$t_f$	---	15	---		

**Typical Electrical/Optical/Characteristics Curves**

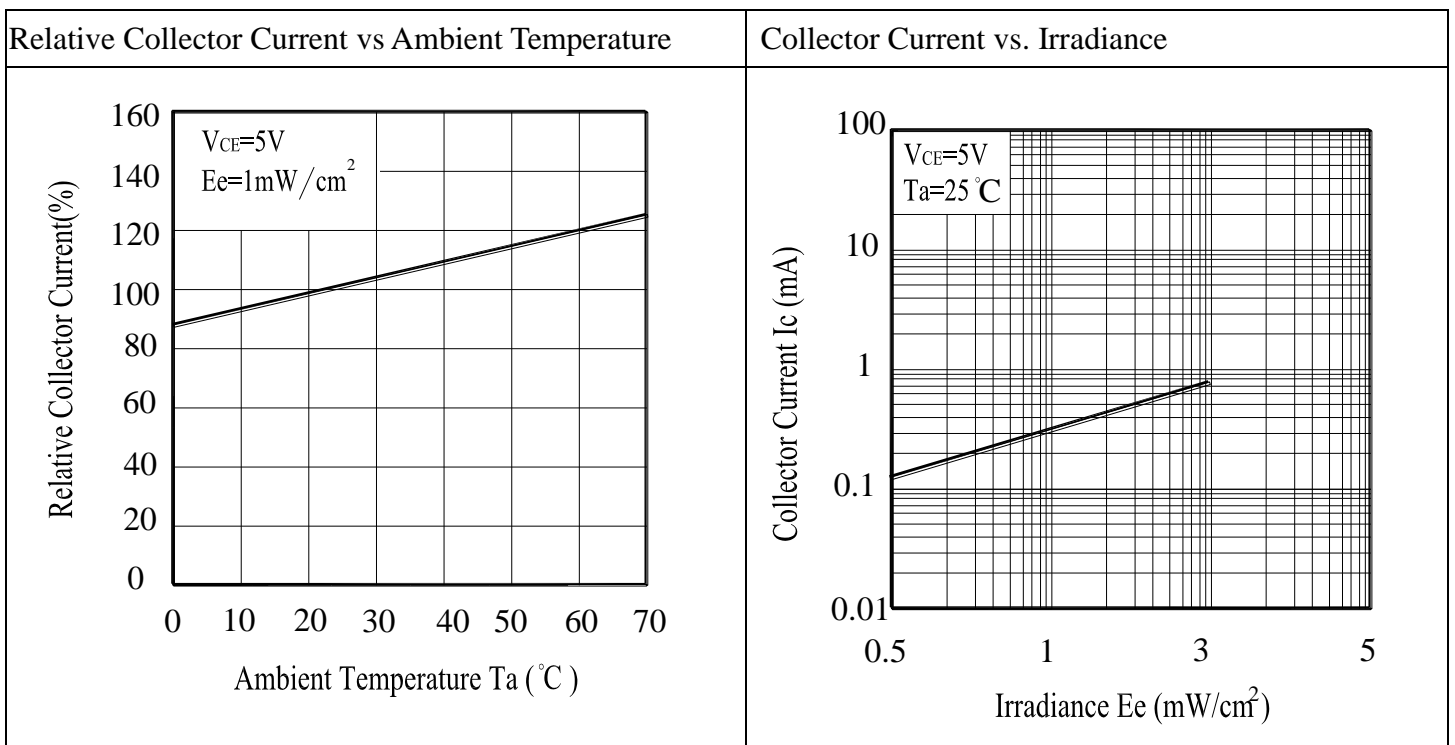
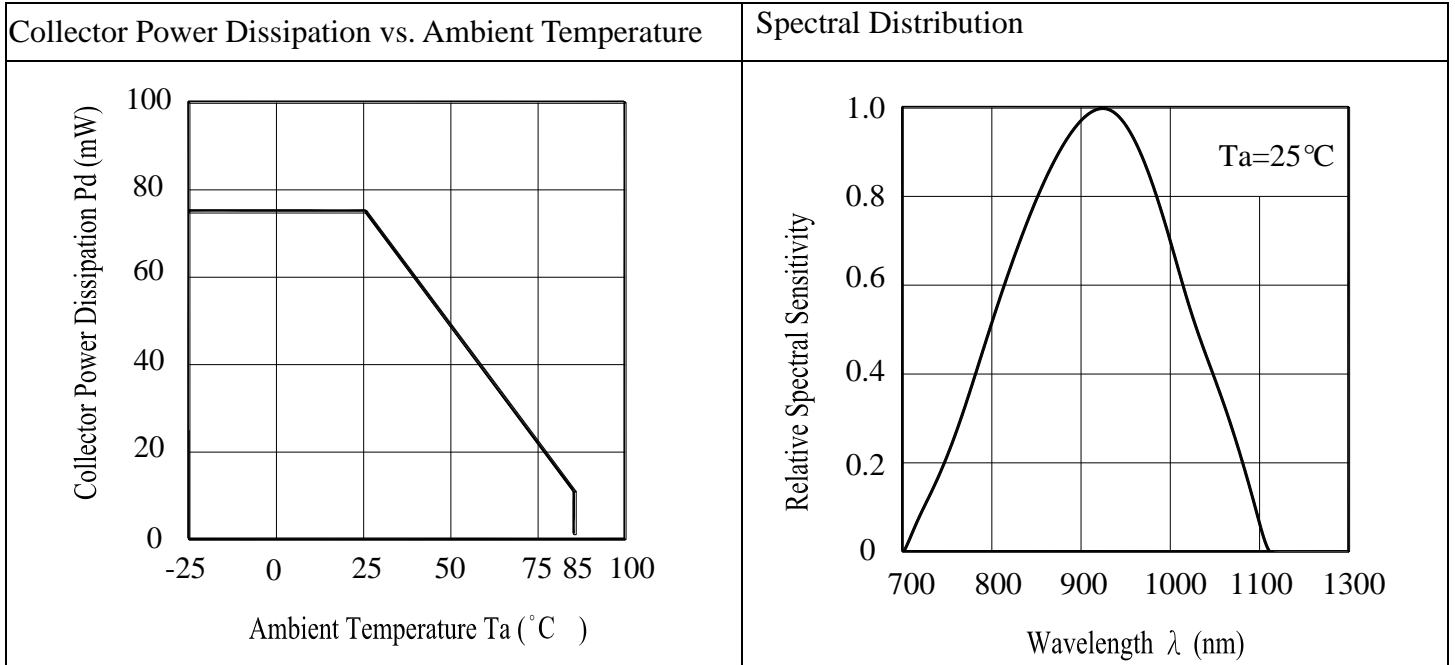

Collector Dark Current vs. Ambient Temperature

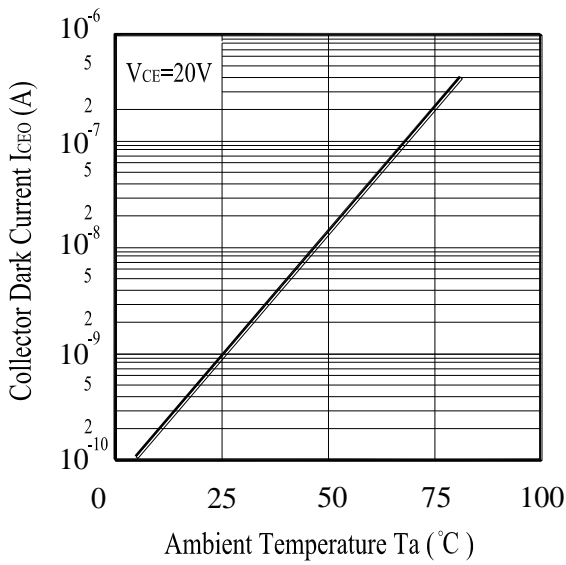

Collector Current vs. Collector-Emitter Voltage

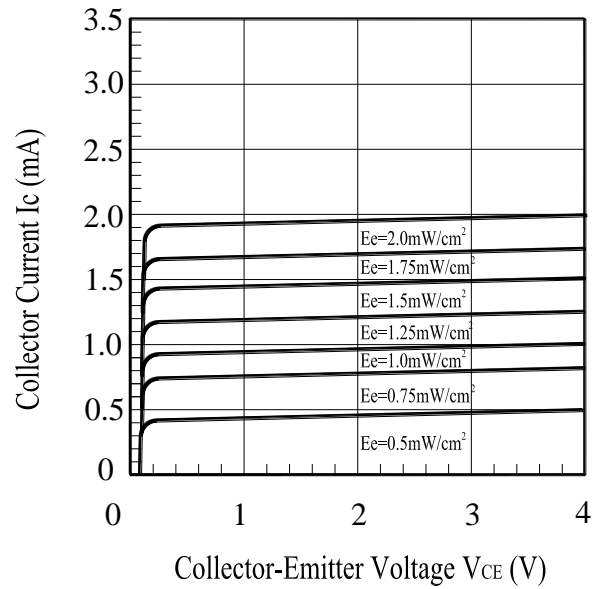

● **Precautions For Use**

1. Over-current-proof

Customer must apply resistors for protection , otherwise slight voltage shift will cause big current change ( Burn out will happen ).

2. Storage

- 2.1 Do not open moisture proof bag before the products are ready to use.
- 2.2 Before opening the package, the LEDs should be kept at 30°C or less and 90%RH or less.
- 2.3 The LEDs should be used within a year.
- 2.4 After opening the package, the LEDs should be kept at 30°C or less and 60%RH or less.
- 2.5 The LEDs should be used within 168 hours (7 days) after opening the package
- 2.6 If the moisture absorbent material (silica gel) has faded away or the LEDs have exceeded the storage time, baking treatment should be performed using the following conditions.  
Baking treatment : 60±5°C for Min. 24 hours.

3. Soldering Condition

3.1 Pb-free solder temperature profile

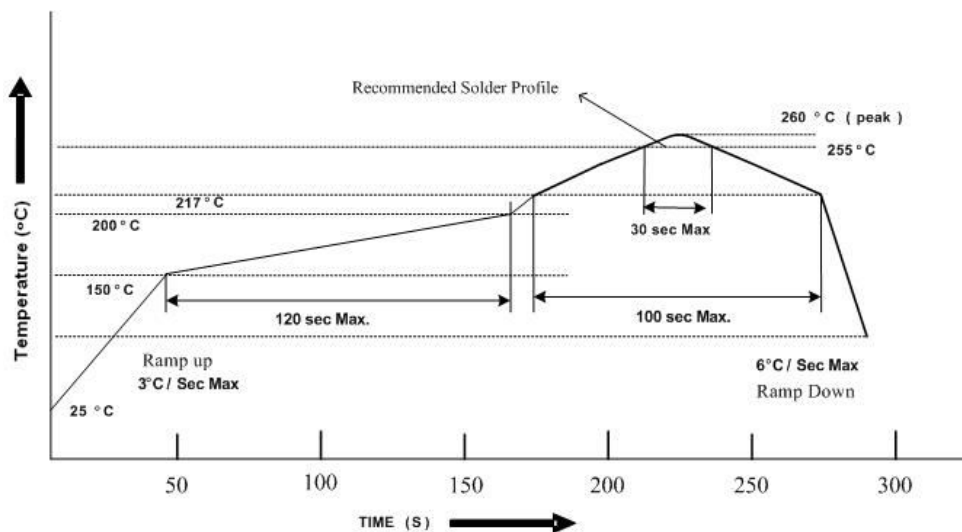

- 3.2 Reflow soldering should not be done more than two times.
- 3.3 When soldering, do not put stress on the LEDs during heating.
- 3.4 After soldering, do not warp the circuit board.

#### 4. Soldering Iron

Each terminal is to go to the tip of soldering iron temperature less than 350°C for 3 seconds within once in less than the soldering iron capacity 25W. Leave two seconds and more intervals, and do soldering of each terminal. Be careful because the damage of the product is often started at the time of the hand solder.

#### 5. Repairing

Repair should not be done after the LEDs have been soldered. When repairing is unavoidable, a double-head soldering iron should be used (as below figure). It should be confirmed beforehand whether the characteristics of the LEDs will or will not be damaged by repairing.



## Package Dimensions

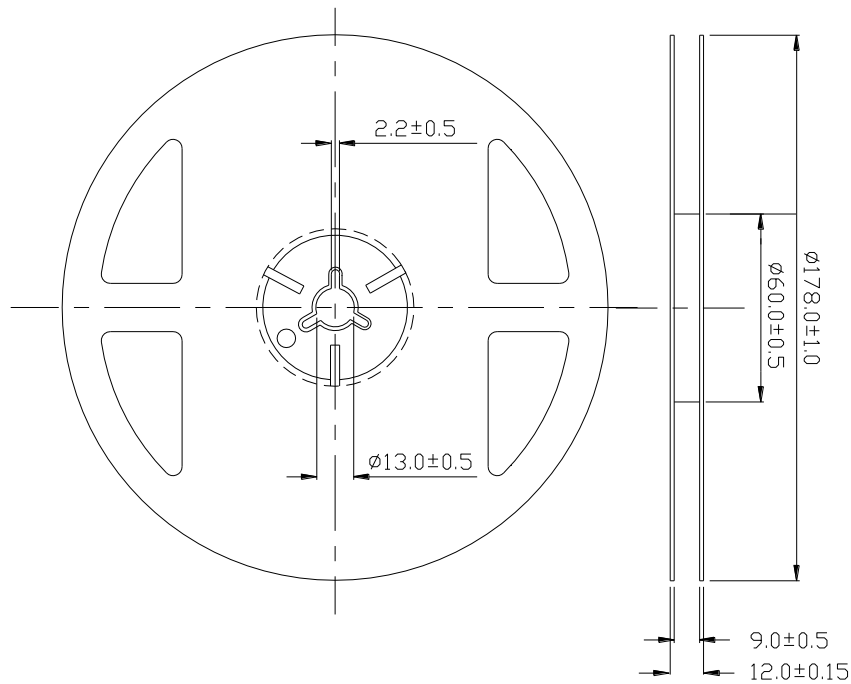

**Note:** The tolerances unless mentioned is  $\pm 0.1 \text{ mm}$ , Unit = mm

### 2. Carrier Tape Dimensions:(Quantity: 2000pcs/reel)

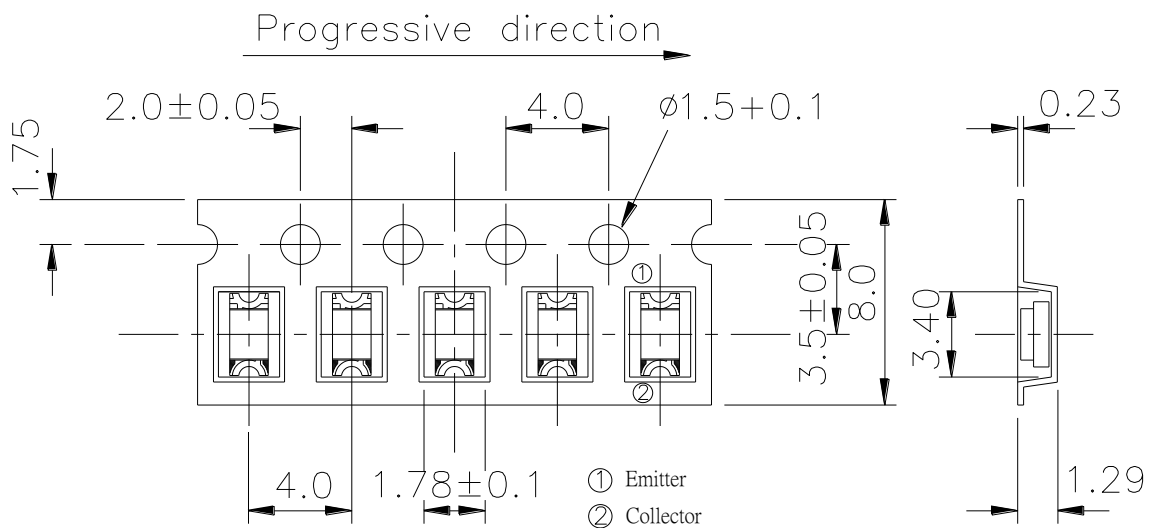

**Note:** The tolerances unless mentioned is  $\pm 0.1 \text{ mm}$ , Unit = mm



## Packing Procedure

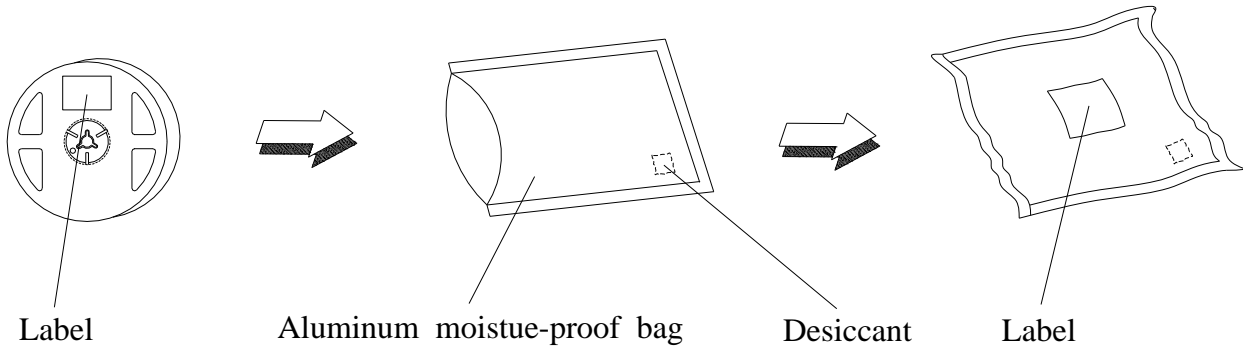

## Label Form Specification

	<b>EVERLIGHT AMERICA</b>	
CPN: XXXXXXXXXXXX		
P/N: XXXXXXXXXXXX		
		<b>RoHS</b>
XXXXXXXXXXXXXXXXXXXX		
QTY: XXXX	CAT: XXX	
	HUE: XXX	
	REF: XXX	
LOT NO: XXXXXXXXXXXXXXXXXXXX		
REFERENCE: XXXXXXXXXXXX		
<b>MADE IN TAIWAN</b>		

CPN: Customer's Production Number  
P/N : Production Number  
QTY: Packing Quantity  
CAT: Ranks  
HUE: Peak Wavelength  
REF: Reference  
LOT No: Lot Number  
MADE IN TAIWAN: Production Place

## Notes

1. Above specification may be changed without notice. Everlight Americas will reserve authority on material change for above specification.
2. When using this product, please observe the absolute maximum ratings and the instructions for using outlined in these specification sheets. Everlight Americas assumes no responsibility for any damage resulting from use of the product which does not comply with the absolute maximum ratings and the instructions included in these specification sheets.
3. These specification sheets include materials protected under copyright of Everlight Americas corporation. Please don't reproduce or cause anyone to reproduce them without Everlight Americas's consent.

## X-ON Electronics

Largest Supplier of Electrical and Electronic Components

*Click to view similar products for [Phototransistors](#) category:*

*Click to view products by [Everlight](#) manufacturer:*

Other Similar products are found below :

[LTR-5576D](#) [PT17-21B/L41/TR8](#) [PT908-7B-F](#) [QSD123A4R0](#) [ASDL-6620-C22](#) [OED-ST-8LR2](#) [OED-STR44B90-TR](#) [SD5410-109](#) [PT15-21B-TR8](#) [PT-IC-AC-3528-520](#) [PT-IC-BC-3528-550](#) [MHT153PTBT](#) [MHS153PTBT](#) [PT26-21C/TR8](#) [PT5529B/L2/H2-F](#) [PT91-21C/TR10](#) [BP 103-3/4](#) [BPX 38-3](#) [BPY 62](#) [KPS-3227SP1C](#) [L-53P3BT](#) [L-53P3C](#) [L-93DP3BT](#) [L-93DP3C](#) [LL-503PTC2E-1AD](#) [LL-S150PTC-1A](#) [LL-S150PTD-1A](#) [SFH 320](#) [SFH 320-3](#) [SFH 320 FA](#) [OP508FA](#) [TEMT1030](#) [LTR-301](#) [PGM5516](#) [PGM5516-MP](#) [PGM5526-MP](#) [PGM5549](#) [PGM5637D](#) [VTT7125H](#) [VEMT4700F-GS08](#) [PT19-21B/L41/TR8](#) [KP-2012P3C](#) [TEKT5400S](#) [SD1410-128L](#) [SFH 313 FA-3/4](#) [SFH 313 FA-2/3](#) [SFH 320-4-Z](#) [SFH 309 FA-5/6](#) [PT4800FE000F](#) [SFH 309-5/6](#)