

T-1(3 mm) Round Shape LED 264-7xx Series

Features:

- SMALL FLANGE WITH STAND-OFF.
- LONG LIFE-SOLID STATE RELIABILITY.
- LONG LEAD LENGTH (25.4mm).

Package Dimensions:

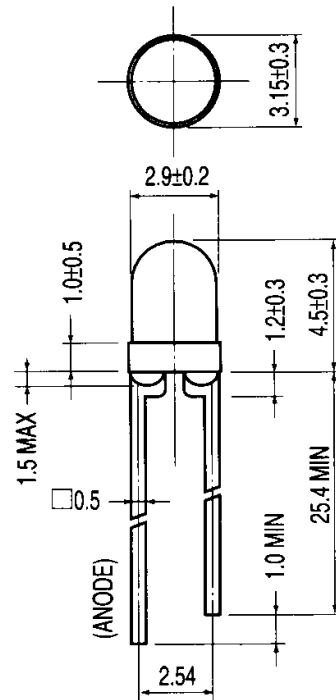

Descriptions:

- The shape of this series is round.
- General application is for indication, illumination, etc.
- These LED lamps are available with a choice of different colors, light intensities, epoxy colors, etc.

NOTES:

1. All dimensions are in millimeters.
2. An epoxy meniscus may extend about 1.5mm (0.059") down the lead.

Selection Guide

MODEL	MATERIAL	LENS COLOR	EMITTED COLOR
EL-264-7HD	GaP	Red Diffused	Bright Red
EL-264-7ID	GaAsP/GaP	Red Diffused	Hi-Eff Red
EL-264-7GD	GaP	Green Diffused	Green
EL-264-7YD	GaAsP/GaP	Yellow Diffused	Yellow
EL-264-7AD	GaAsP/GaP	Amber Diffused	Amber
EL-264-7HT	GaP	Red Trans.	Bright Red
EL-264-7IT	GaAsP/GaP	Red Trans.	Hi-Eff Red
EL-264-7GT	GaP	Green Trans.	Green
EL-264-7YT	GaAsP/GaP	Yellow Trans.	Yellow

Absolute Maximum Ratings at Ta=25°C

PARAMETER	BRIGHT RED	HI.EFF. RED ORANGE	GREEN	YELLOW	AMBER	UNIT
Power Dissipation	45	100	100	85	85	mW
Peak Forward Current (1/10 Duty Cycle, 0.1ms Pulse Width)	50	160	160	160	160	mA
Continuous Forward Current	15	30	30	20	20	mA
Reverse Voltage	5	5	5	5	5	V
Operating Temperature Range	-40°C to -85°C					
Storage Temperature Range	-40°C to 100°C					
Lead Soldering Temperature [1.6mm(0.063in)From Body]	260°C for 5 seconds					

Optical/Electrical Characteristics at Ta=25°C

MODEL	λ_p	ELECTRO-OPTICAL CHARACTERISTICS (At 10mA)					VIEWING ANGLE 2 θ 1/2
		Vf(V)			Iv(mcd)		
		Min.	Typ.	Max.	Min.	Typ.	(deg)
EL-264-7HD	697	1.7	2.1	2.8	1.6	2.8	60
EL-264-7ID	635	1.7	2.0	2.8	4.0	6.3	60
EL-264-7GD	565	1.7	2.1	2.8	6.3	10	60
EL-264-7YD	585	1.7	2.0	2.8	6.3	10	60
EL-264-7AD	600	1.7	2.0	2.8	6.3	1.0	60
EL-264-7HT	697	1.7	2.1	2.8	2.0	4.0	40
EL-264-7IT	635	1.7	2.0	2.8	10	16	40
EL-264-7GT	565	1.7	2.1	2.8	16	25	40
EL-264-7YT	585	1.7	2.0	2.8	10	16	40

Viewing Angle:

60°

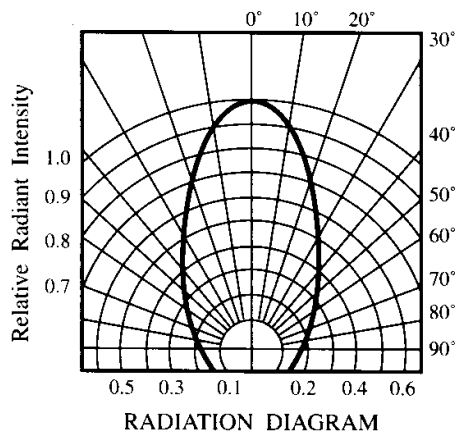

40°

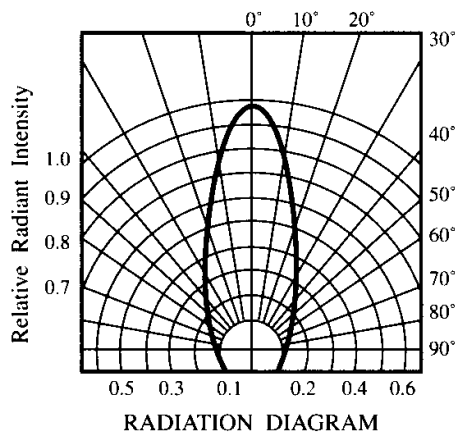

264-7HD Series:

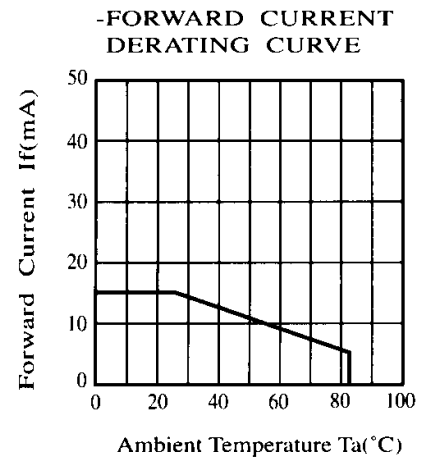
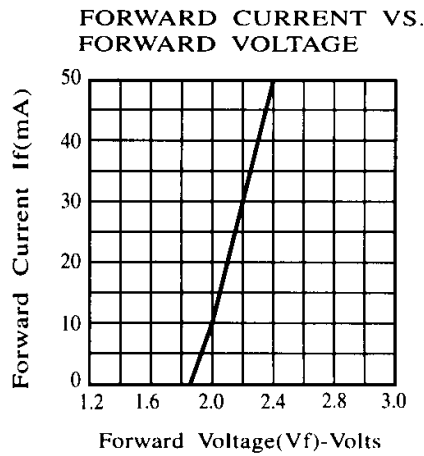
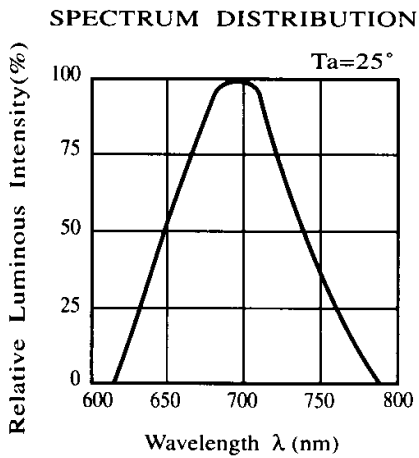

264-7ID Series:

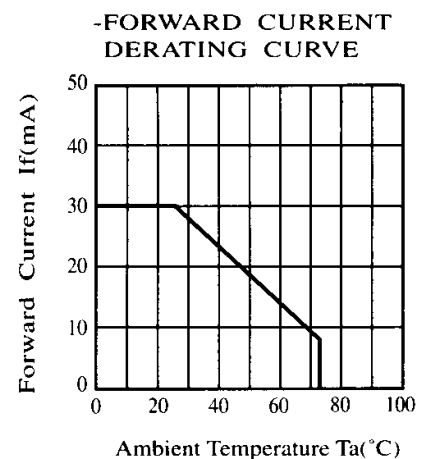
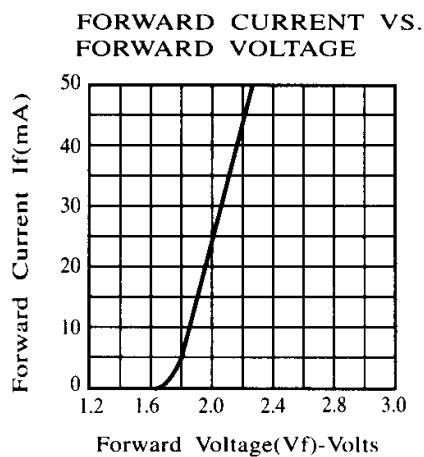
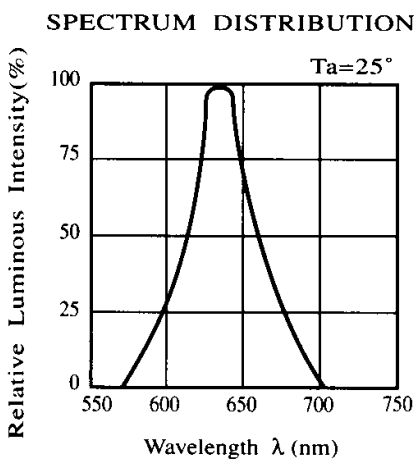

264-7GD Series:

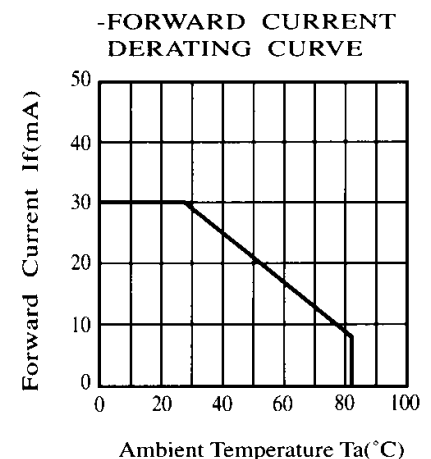
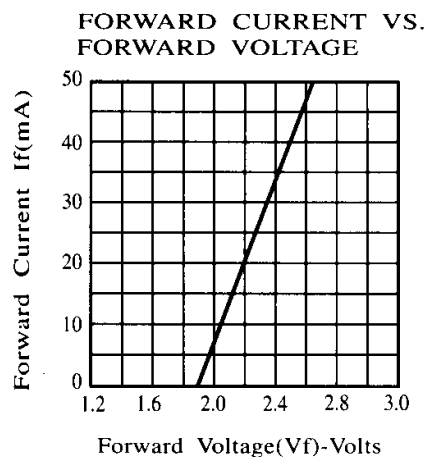
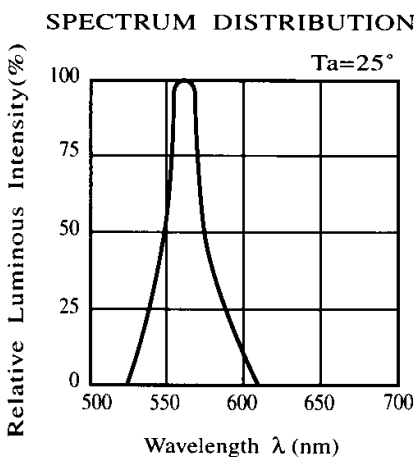

264-7YD Series:

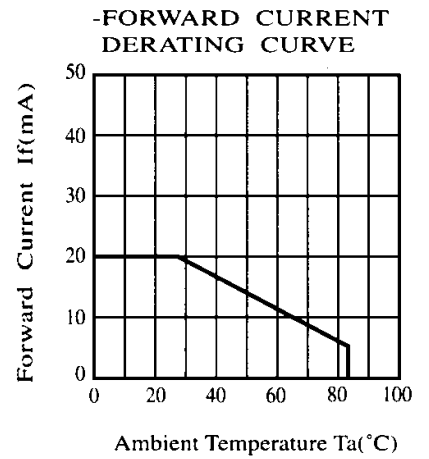
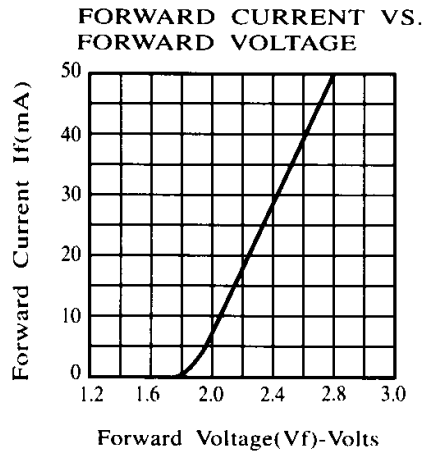
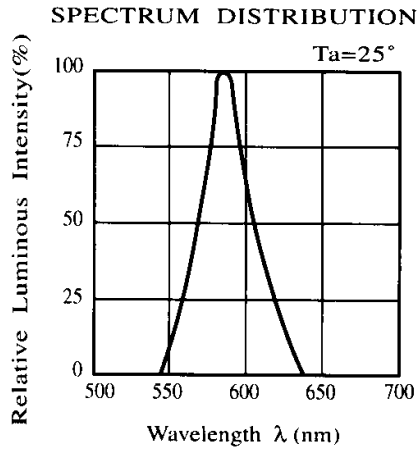

264-7AD Series:

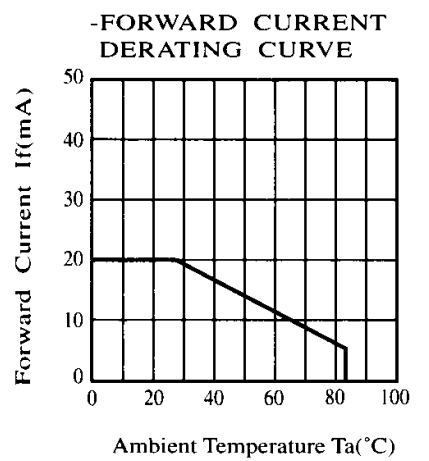
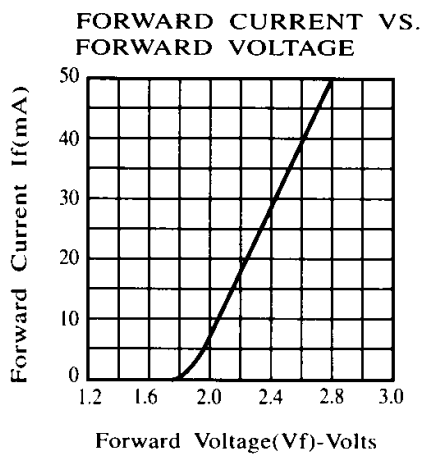
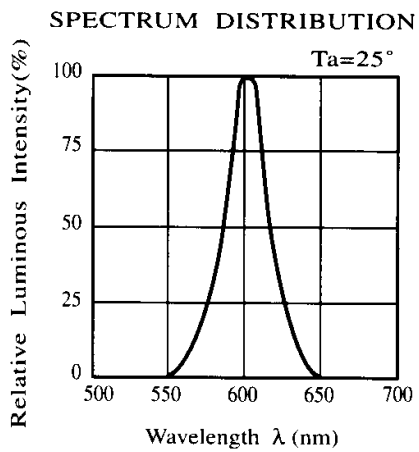

X-ON Electronics

Largest Supplier of Electrical and Electronic Components

Click to view similar products for [Standard LEDs - Through Hole category:](#)

Click to view products by [Everlight manufacturer:](#)

Other Similar products are found below :

[LTL-10254W](#) [LTL-1214A](#) [LTL-2231AT](#) [LTL-3251A](#) [LTL-4262N](#) [LTL-433P](#) [LTL-5234](#) [LTL87HTBK](#) [LTL-87HD4B](#) [HLMP-EL30-PS0DD](#) [1L0532V23G0TD001](#) [NSPW500CS](#) [LD CQDP-1U3U-W5-1-K](#) [LP379PPG1C0G0300001](#) [SLR-342MC3F](#) [SLX-LX3044GD](#) [SLX-LX3044ID](#) [SLX-LX3044YD](#) [1.90690.3330000](#) [SSS-LX4673ID-410B](#) [1L0532Y24I0TD001](#) [264-7SYGD/S530-E2](#) [HLMP-1301-G00FG](#) [HLMP1385](#) [LTL-10224W](#) [LTL-1224A](#) [LTL-1234A](#) [LTL-2251AT](#) [LTL-403HR](#) [LTL-4222](#) [LU7-E-B](#) [4380H1](#) [HLMP-3962-F0002](#) [HLMP-GG15-R0000](#) [323-2SURD/S530-A3](#) [L53SRC/E-Z](#) [L-7679C1ZGC](#) [4302T1-5V](#) [4306D23](#) [4363D1/5](#) [WP1503SRC/J4](#) [WP153YDT](#) [WP1543SGC](#) [WP1543SURC](#) [WP53MGD](#) [WP7113HD](#) [WP7113MBD](#) [WP7113MGC](#) [WP7143SEC/H](#) [Z-221A](#)