

Technical Data Sheet

1026 Package Chip LED with Inner Lens(1.1mm Height)

HIR25-21C/L423/2T

Features

- Small double-end package
- Low forward voltage
- Good spectral matching to Si photo detector
- Package in 8mm tape on 7" diameter reel.
- Pb free
- The product itself will remain within RoHS compliant version.

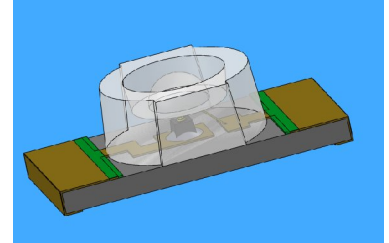

Descriptions

- HIR25-21C/L423/2T is an infrared emitting diode in miniature SMD package which is molded in a water clear plastic with spherical top view lens. The device is spectrally matched with silicon photodiode and phototransistor

Applications

- PCB mounted infrared sensor
- Infrared remote control units with high power requirement
- Scanner
- Infrared applied system

Device Selection Guide

Part No.	Chip	Resin Color
	Material	
HIR	GaAlAs	Water clear

Package Dimensions

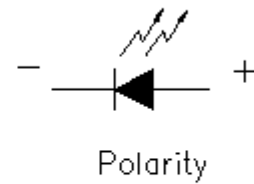
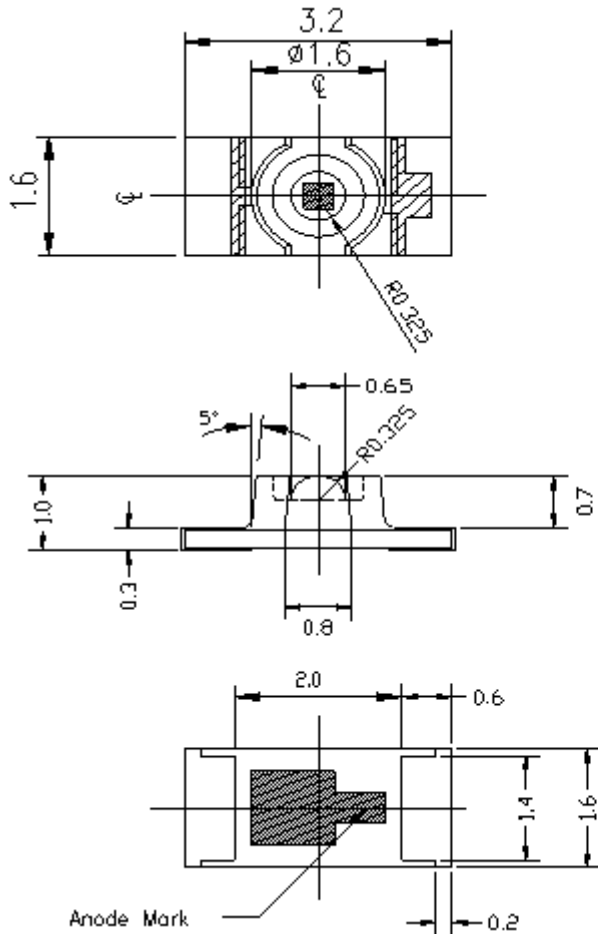

For Reflow Soldering

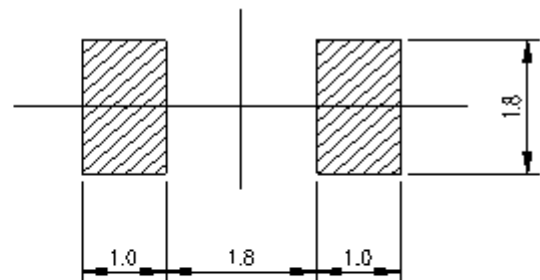

- Notes:**
- 1.All dimensions are in millimeters
 - 2.Tolerances unless dimensions ± 0.1 mm

Absolute Maximum Ratings (Ta=25)

Parameter	Symbol	Rating	Units
Continuous Forward Current	I _F	50	mA
Peak Forward Current(300pps,10us pulse)	I _{FP}	800	mA
Reverse Voltage	V _R	5.0	V
Operating Junction Temperature	T _j	105	
Operating Temperature	T _{opr}	-40 ~ +85	
Storage Temperature	T _{stg}	-40 ~ +85	
Soldering Temperature	T _{sol}	260	
Total Power Dissipation	P _t	100	mW
Power Dissipation at(or below) 25 Free Air Temperature	P _d	110	mW

Electro-Optical Characteristics (Ta=25)

Parameter	Symbol	Condition	Min.	Typ.	Max.	Units
Radiant Intensity	I _e	I _F =20mA	3.0	5.5	9.0	mW/sr
Peak Wavelength	λ	I _F =20mA	--	850	--	nm
Spectral Bandwidth		I _F =20mA	--	42	--	nm
Forward Voltage	V _F	I _F =50mA	1.30	1.60	2.00	V
Reverse Current	I _R	V _R =5V	--	--	10	μ A
Optical rise and fall time	t _r /t _f	I _F =20mA	--	25/15	35/35	ns
View Angle	2 1/2	I _F =20mA	--	70	--	deg

Typical Electro-Optical Characteristics Curves

Fig.1 Forward Current vs.

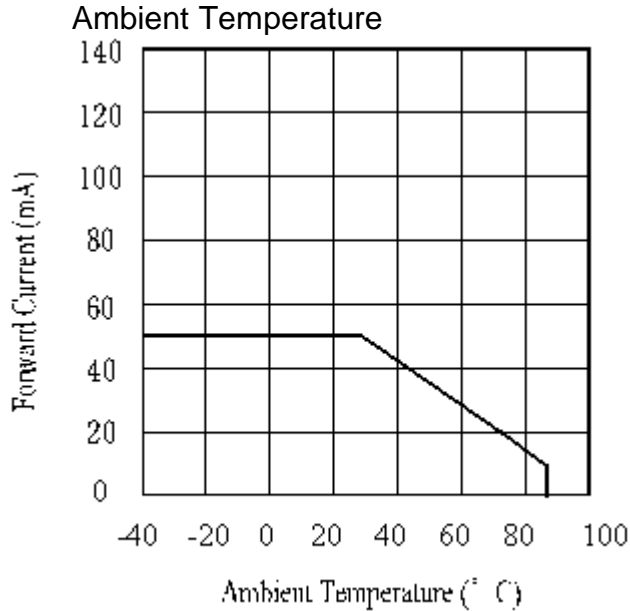

Fig.2 Spectral Distribution

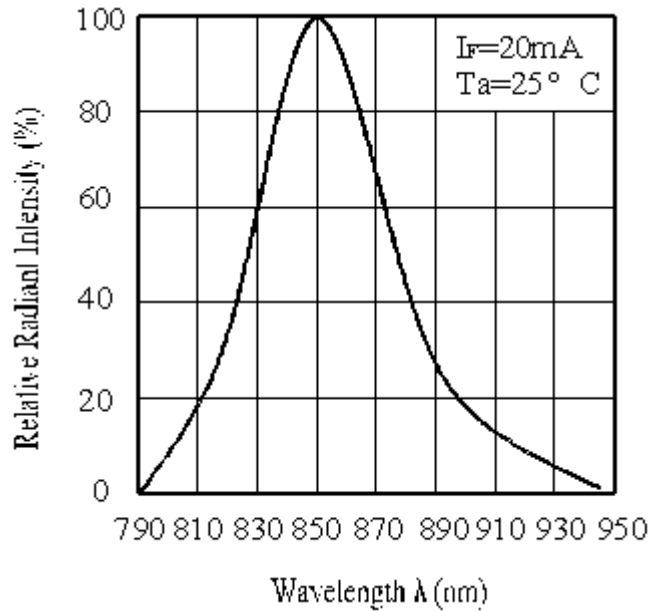

Fig.3 Peak Emission Wavelength

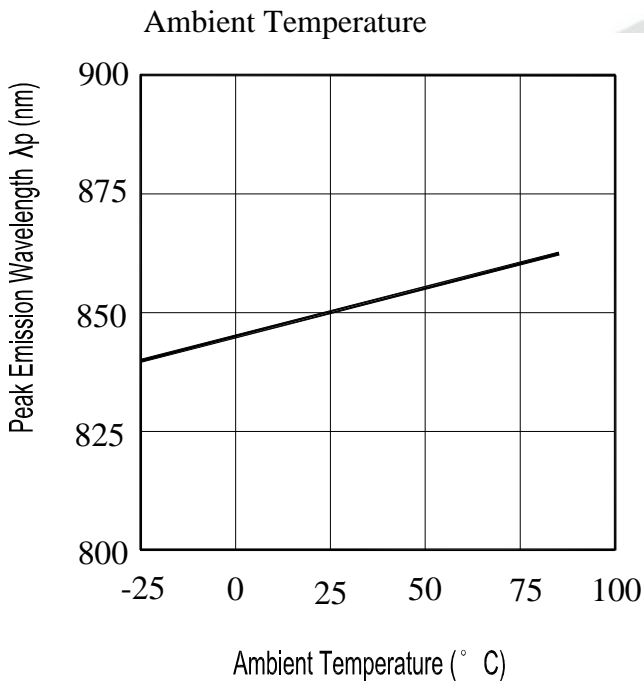
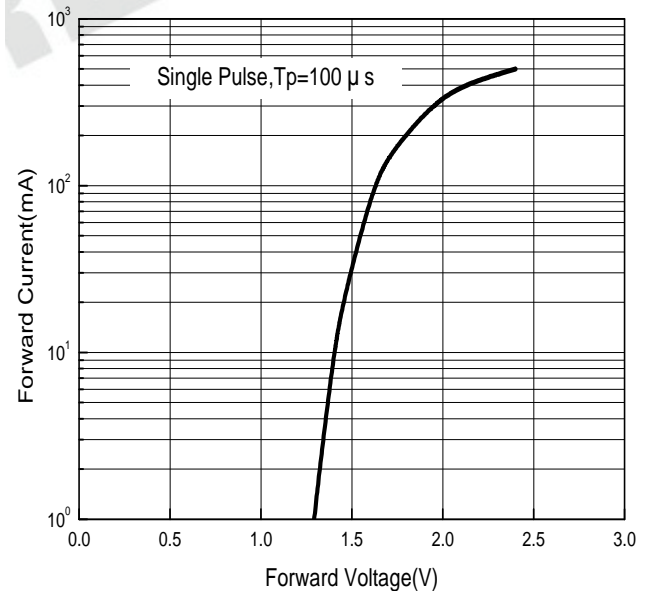

Fig.4 Forward Current vs. Forward Voltage



Typical Electro-Optical Characteristics Curves

Fig.5 Radiant Intensity vs. Forward Current

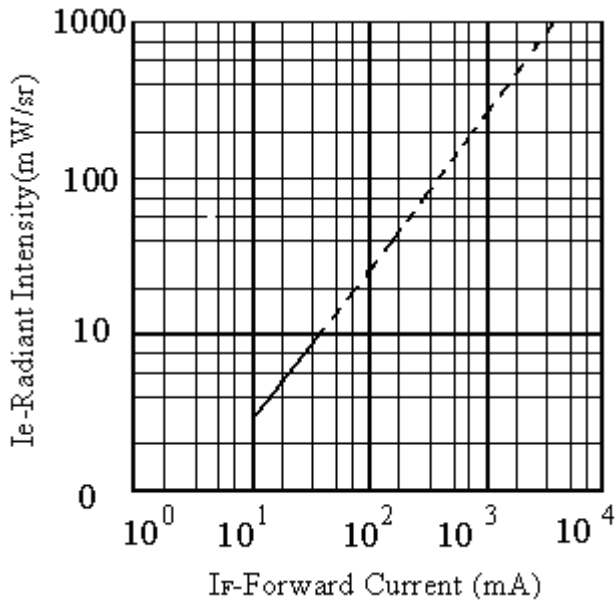
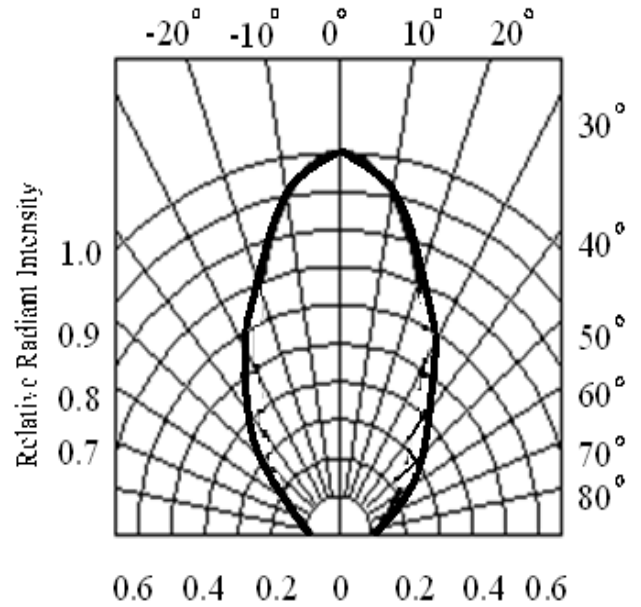

Fig.6 Relative Radiant Intensity vs. Angular Displacement



EVERLIGHT

Precautions For Use

1. Over-current-proof

Customer must apply resistors for protection , otherwise slight voltage shift will cause big current change (Burn out will happen).

2. Storage

2.1 Do not open moisture proof bag before the products are ready to use.

2.2 Before opening the package, the LEDs should be kept at 30 or less and 90%RH or less.

2.3 After opening the package: The LED's floor life is 1 year under 30 or less and 60% RH or less.

If unused LEDs remain, it should be stored in moisture proof packages.

2.4 If the moisture absorbent material (silica gel) has faded away or the LEDs have exceeded the storage time, baking treatment should be performed using the following conditions.

Baking treatment : 60 ± 5 for 24 hours.

2.5 This product accords with LEVEL3 grade, consult J-STD-020-C-1 concretly.

3. Soldering Condition

3.1 Pb-free solder temperature profile

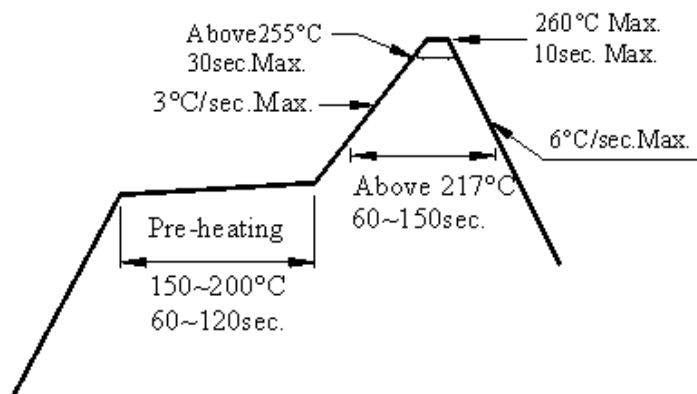

3.2 Reflow soldering should not be done more than two times.

3.3 When soldering, do not put stress on the LEDs during heating.

3.4 After soldering, do not warp the circuit board.

4.Soldering Iron

Each terminal is to go to the tip of soldering iron temperature less than 350 for 3 seconds within once in less than the soldering iron capacity 25W. Leave two seconds and more intervals, and do soldering of each terminal. Be careful because the damage of the product is often started at the time of the hand solder.

5.Repairing

Repair should not be done after the LEDs have been soldered. When repairing is unavoidable, a double-head soldering iron should be used (as below figure). It should be confirmed beforehand whether the characteristics of the LEDs will or will not be damaged by repairing.

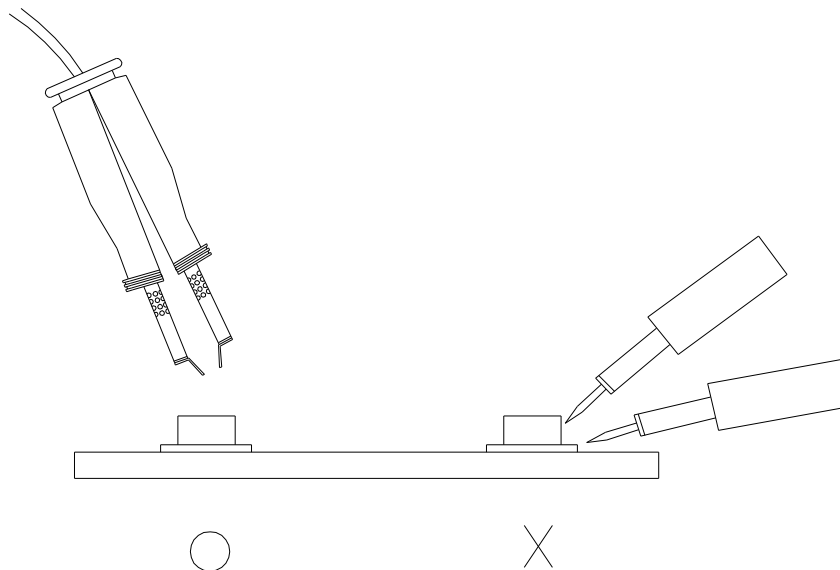

Reliability Test Item And Condition

The reliability of products shall be satisfied with items listed below.

Confidence level : 90%

LTPD : 10%

NO.	Item	Test Conditions	Test Hours/ Cycles	Sample Sizes	Failure Judgement Criteria	Ac/Re
1	REFLOW Soldering	TEMP. : 260 ±5 10secs	6Mins	22pcs	I _R U×2	0/1
2	Temperature Cycle	H : +100 15mins ↕ 5mins L : -40 15mins	300Cycles	22pcs	I _e L×0.8 V _F U×1.2	0/1
3	Thermal Shock	H : +100 5mins ↕ 10secs L : -10 5mins	300Cycles	22pcs	U : Upper Specification Limit	0/1
4	High Temperature Storage	TEMP. : +100	1000hrs	22pcs	L : Lower Specification Limit	0/1
5	Low Temperature Storage	TEMP. : -40	1000hrs	22pcs		0/1
6	DC Operating Life	I _F =20mA/25	1000hrs	22pcs		0/1
7	High Temperature/ High Humidity	85 / 85% R.H	1000hrs	22pcs		0/1

Package Dimensions

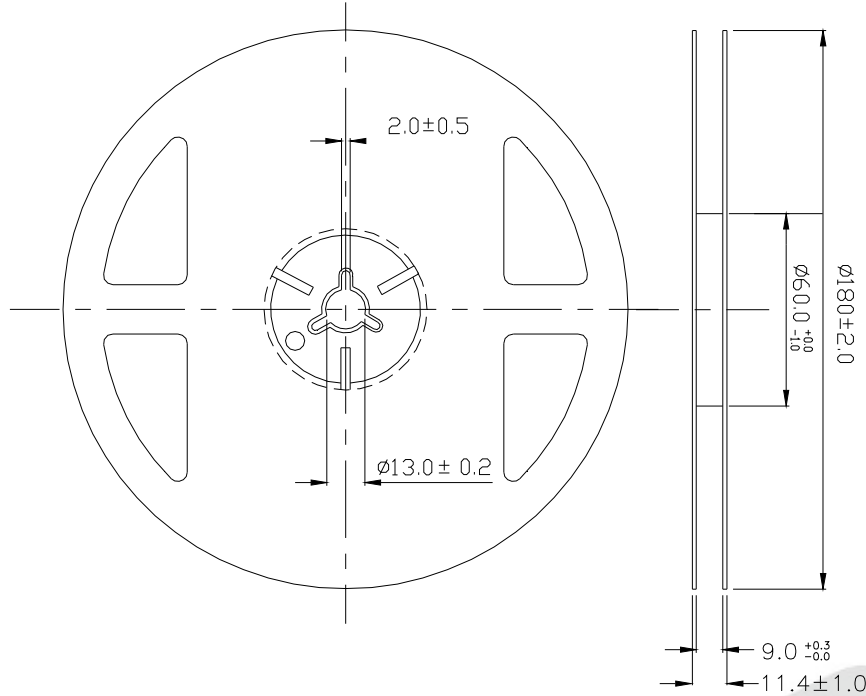

Carrier Tape Dimensions: Loaded quantity 2000 PCS per reel

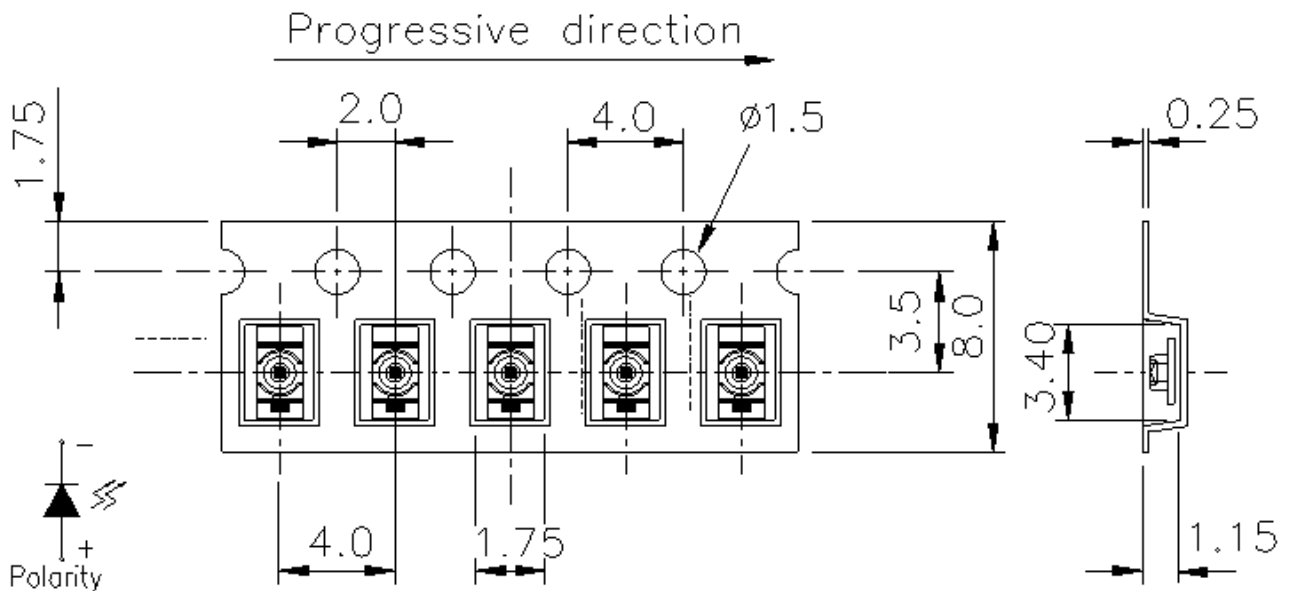

Note: The tolerances unless mentioned is $\pm 0.1\text{mm}$, Unit = mm

Label Form Specification

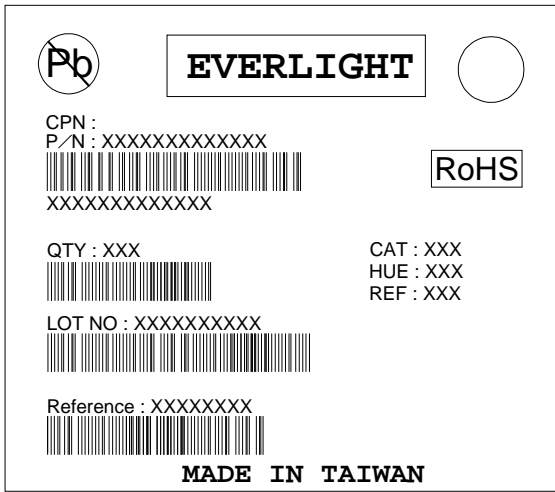

CPN: Customer's Production Number
P/N : Production Number
QTY: Packing Quantity
CAT: Ranks
HUE: Peak Wavelength
REF: Reference
LOT No: Lot Number
MADE IN TAIWAN: Production Place

Notes

1. Above specification may be changed without notice. EVERLIGHT will reserve authority on material change for above specification.
2. When using this product, please observe the absolute maximum ratings and the instructions for using outlined in these specification sheets. EVERLIGHT assumes no responsibility for any damage resulting from use of the product which does not comply with the absolute maximum ratings and the instructions included in these specification sheets.
3. These specification sheets include materials protected under copyright of EVERLIGHT corporation. Please don't reproduce or cause anyone to reproduce them without EVERLIGHT's consent.

EVERLIGHT ELECTRONICS CO., LTD.
Office: No 25, Lane 76, Sec 3, Chung Yang Rd,
Tucheng, Taipei 236, Taiwan, R.O.C

Tel: 886-2-2267-2000, 2267-9936
Fax: 886-2267-6244, 2267-6189, 2267-6306
<http://www.everlight.com>

X-ON Electronics

Largest Supplier of Electrical and Electronic Components

Click to view similar products for [Infrared Emitters](#) category:

Click to view products by [Everlight](#) manufacturer:

Other Similar products are found below :

[LTE-3279K](#) [LTE-4206C](#) [LTE-4208C](#) [EAILP03RDAA6](#) [LTE-2871C](#) [LTE-4238](#) [ASDL-4264-C22](#) [EAIPL3528Z0](#) [OED-EL305F4C50-HT](#)
[OP216-004](#) [LTE-3376](#) [IN-S126ETIR](#) [IN-S126DSHIR](#) [IN-S126ETHIR](#) [IN-P32ZTHIR](#) [IN-S42CTQHIR](#) [IN-S63DTHIR](#) [IN-S85BTHIR](#) [IN-](#)
[S63FTHIR](#) [HIR204C/H0](#) [HIR204/H0](#) [HIR323C](#) [LTE-209](#) [IR12-21C/TR8](#) [IR17-21C/TR8](#) [IR26-21C/L110/TR8](#) [IR383](#) [IR91-21C/TR10](#) [KM-](#)
[4457F3C](#) [L-53F3BT](#) [WP7113F3BT](#) [WP7113F3C](#) [LTE-4208](#) [OP235W](#) [OP297FAB](#) [WP7113SF6C](#) [IR67-21CTR8](#) [IR42-21C/TR8](#) [IR204C-A](#)
[HSDL-4261](#) [APT1608SF4C-PRV](#) [APA3010F3C-GX](#) [MTE1077N1-R](#) [MTE1081C](#) [MTE1300N](#) [MTE8600M2](#) [MTE9440M3A](#) [MTE9440N](#)
[MTE9460MC](#) [MTMS8800T38](#)