

### ITR1204SR10A/TR(BY)

#### Features

- High sensitivity
- Cut-Off visible wavelength
- Compliance Halogen Free(Br < 900ppm, Cl < 900ppm, Br+Cl < 1500ppm)
- Compliance with EU REACH
- This product itself will remain within RoHS compliant version.

#### Description

The SMD type ITR1204SR10A/TR(BY) consists of an infrared emitting diode and an silicon phototransistor. The phototransistor receives radiation from the IR only. This is the normal situation. But when a reflecting object close to ITR, phototransistor receives the reflecting radiation and the different distance have different light current.

#### Applications

- Printer
- Switch Scanner
- Non-contact Switching

#### Device Selection Guide

Device No.	Chip Material	Lens Color
IR	GaAs	Black clear
PT	Silicon	Black clear

Package Dimensions

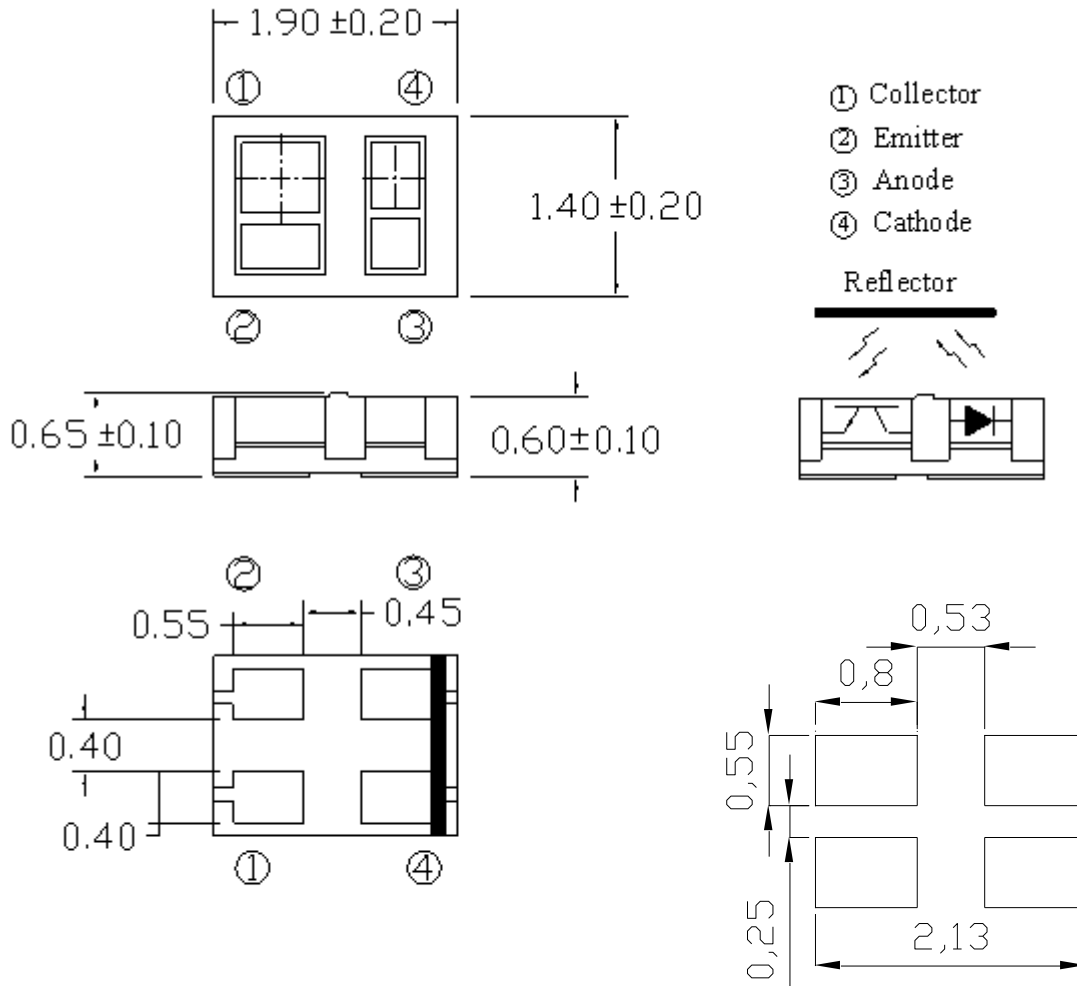

Recommended Soldering Pattern

Notes:

1. All dimensions are in millimeters
2. Tolerances unless dimensions ±0.2mm
3. Lead spacing is measured where the lead emerge from the package

**Absolute Maximum Ratings (Ta=25°C)**

Parameter		Symbol	Ratings	Unit
Input	Power Dissipation at(or below) 25°C Free Air Temperature	Pd	75	mW
	Reverse Voltage	V <sub>R</sub>	6	V
	Forward Current	I <sub>F</sub>	50	mA
Output	Collector Power Dissipation	P <sub>C</sub>	75	mW
	Collector Current	I <sub>C</sub>	20	mA
	Collector-Emitter Voltage	B V <sub>CEO</sub>	30	V
	Emitter-Collector Voltage	B V <sub>ECO</sub>	5	V
Operating Temperature		Topr	-25~+85	°C
Storage Temperature		Tstg	-40~+100	°C
Lead Soldering Temperature (*1)		Tsol	260	°C

(\*1) t ≤ 5 Sec

**Electro-Optical Characteristics (Ta=25°C)**

Parameter		Symbol	Min.	Typ.	Max.	Unit	Condition
Input	Forward Voltage	V <sub>F</sub>	-	1.25	1.5	V	I <sub>F</sub> =4mA
	Reverse Current	I <sub>R</sub>	-	-	10	μA	V <sub>R</sub> =6V
	Peak Wavelength	λ <sub>p</sub>	-	940	-	nm	I <sub>F</sub> =20mA
Output	Dark Current	I <sub>CEO</sub>	-	-	0.1	uA	V <sub>CE</sub> =10V
Transfer Characteristics	Collect Current	I <sub>C(ON)</sub>	70	-	130	μA	V <sub>CE</sub> =2V, I <sub>F</sub> =4mA
	Operating Dark Current*	I <sub>CEOD</sub>			1	μA	V <sub>CE</sub> =2V, I <sub>F</sub> =2mA
	Rise Time	T <sub>r</sub>	-	15	-	μs	V <sub>CE</sub> =2V I <sub>C</sub> =0.1mA R <sub>L</sub> =1000Ω
	Fall Time	T <sub>f</sub>	-	15	-	μs	

\*Operating dark current may be affected by surrounding situation.

Opto Characteristic Curves

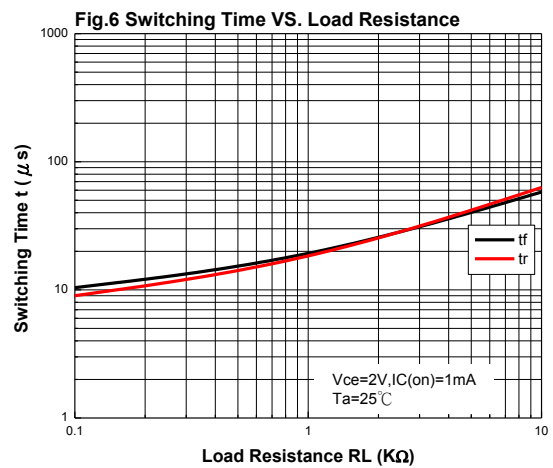
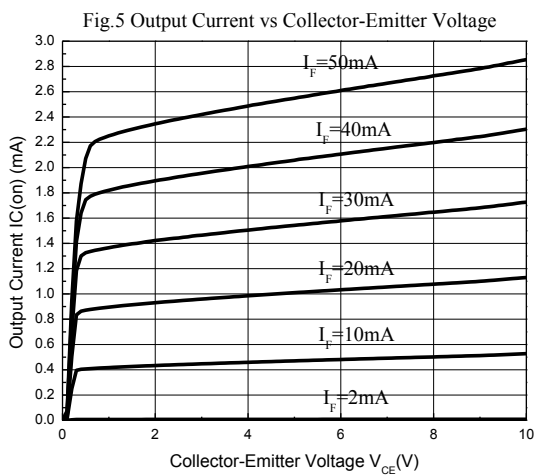
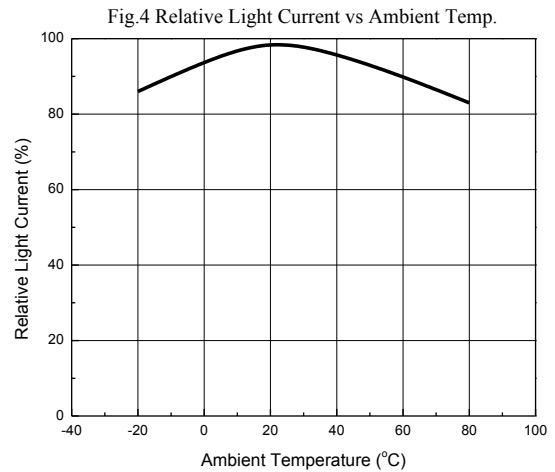
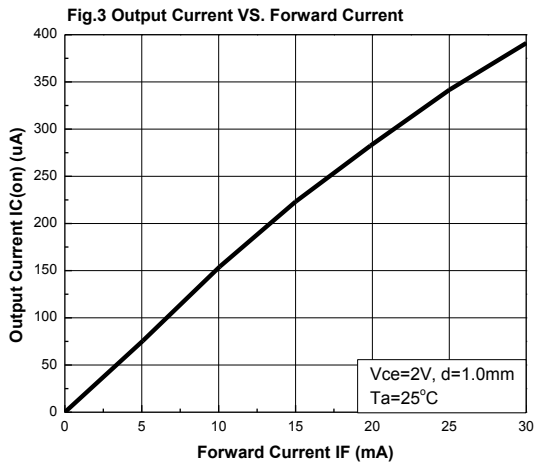
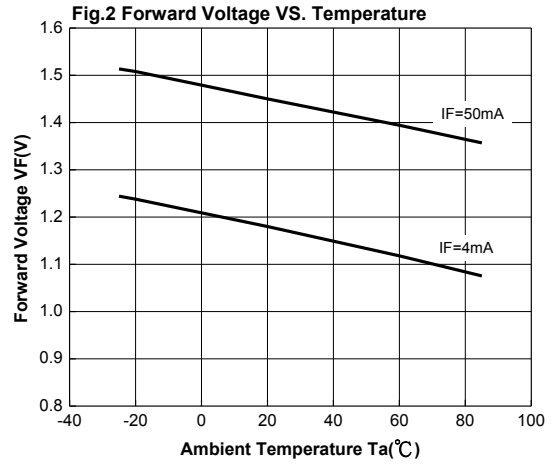
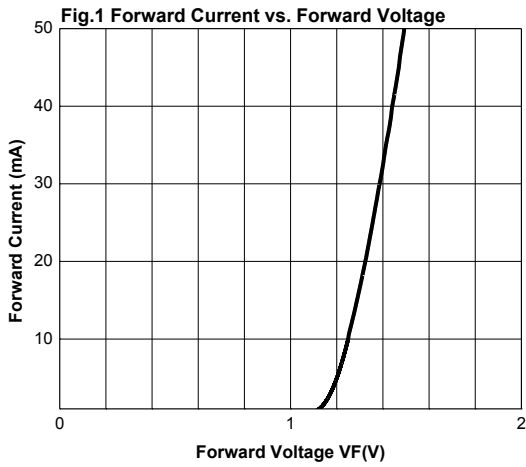

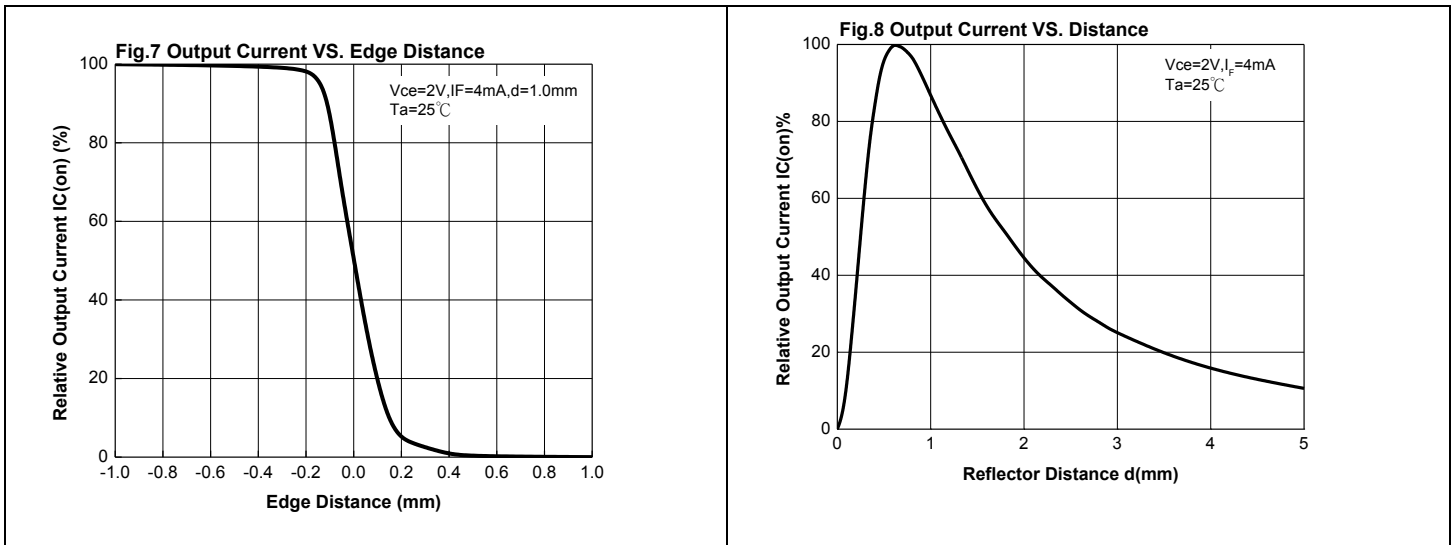

**Measuring Specification For Reflector Response**

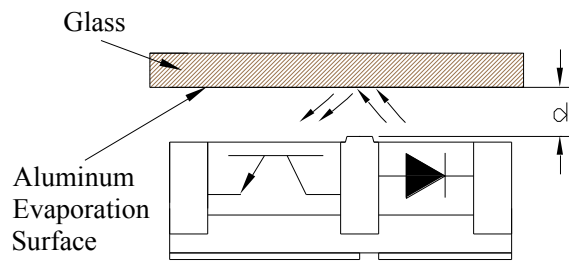

**Measuring Specification For Edge Response**

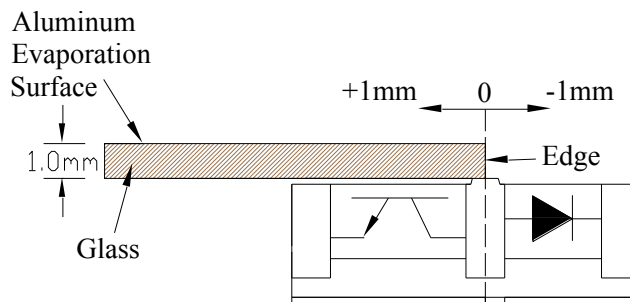

**Measuring Circuit For Response Time**

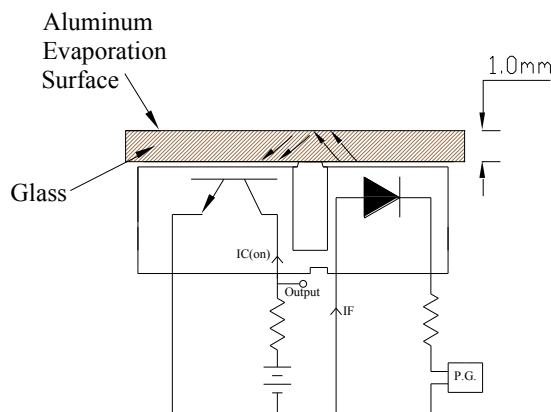

**Package Dimensions**

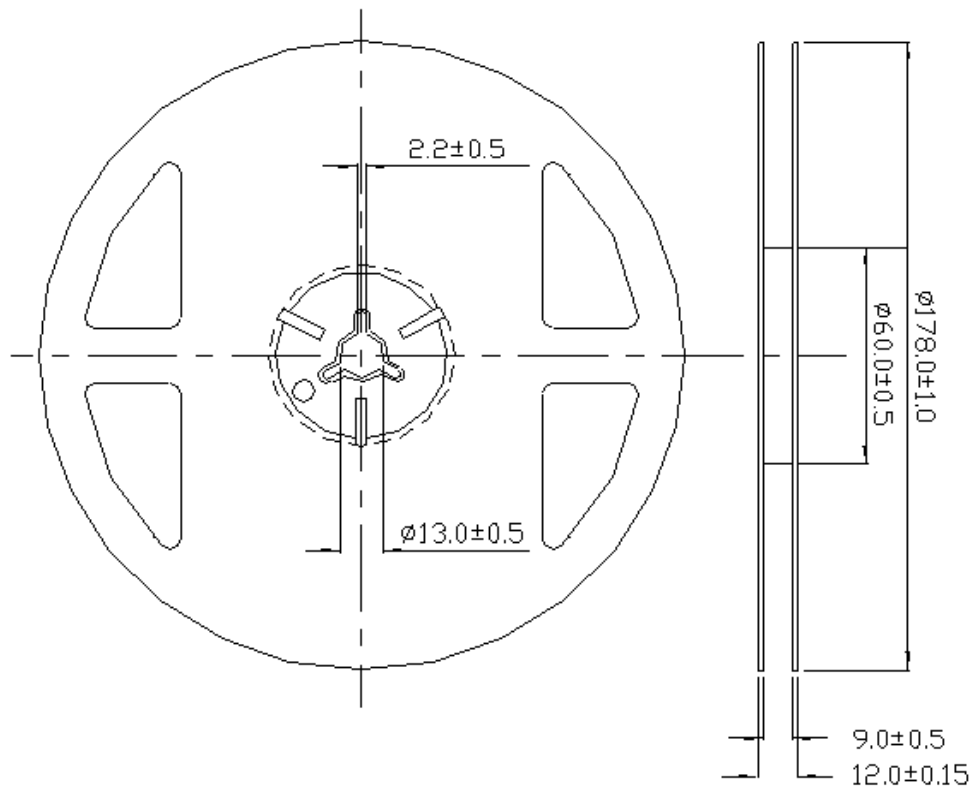

**Taping Dimension**

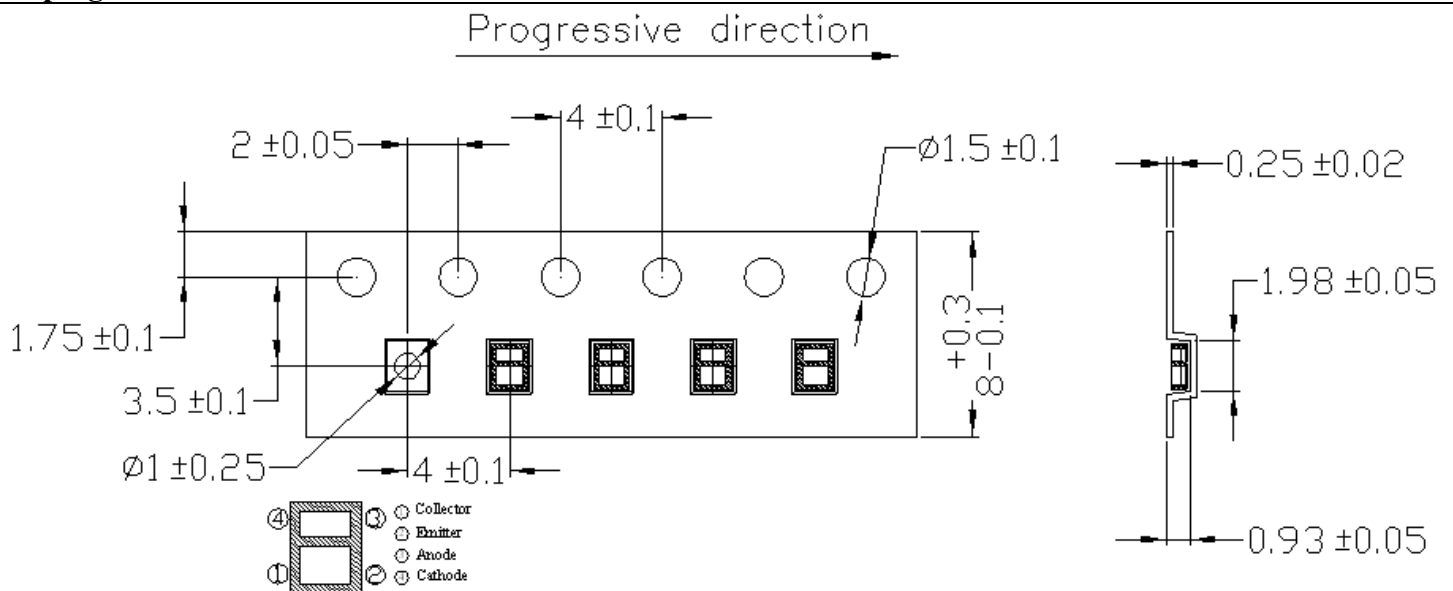

**Packing Quantity Specification**

1.2000PCS/1Bag , 10Bags/1Box

2.10Boxes/1Carton

## Packing Procedure

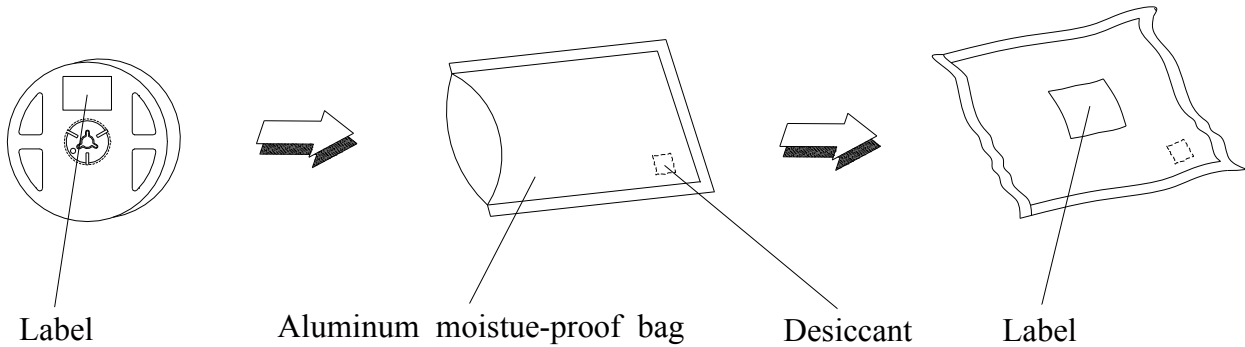

**Outer Carton Dimension : 409mm(A)\*245mm(B)\*360mm(C)**

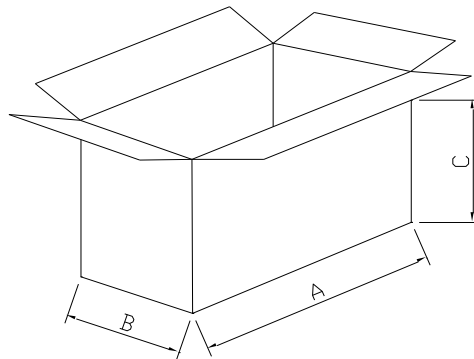

## Recommended Method of Storage

The following are general recommendations for moisture sensitive level (MSL) 3 storage and use :

### 1. Storage

- 1.1 Do not open moisture proof bag before the products are ready to use.
- 1.2 Before opening the package, the device should be kept at 30°C or less and 90%RH or less.
- 1.3 The device should be used within a year.
- 1.4 After opening the package, the device should be kept at 30°C or less and 70%RH or less.
- 1.5 The device should be used within 168 hours (7 days) after opening the package.
- 1.6 If the moisture absorbent material (silica gel) has faded away or the device have exceeded the storage time, baking treatment should be performed using the following conditions. Baking treatment : 60±5°C for 24 hours.

2. Soldering Condition

- a) Pb-free solder temperature profile
- b) Reflow soldering should not be done more than two times.
- c) When soldering, do not put stress on the LEDs during heating.
- d) After soldering, do not warp the circuit board.

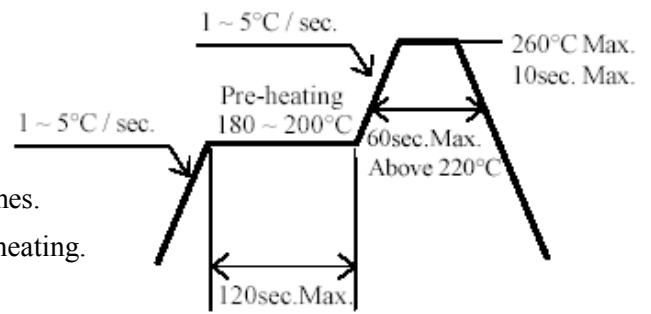

Repairing

Repair should not be done after the LEDs have been soldered. When repairing is unavoidable, a double-head soldering iron should be used (as below figure). It should be confirmed beforehand whether the characteristics of the LEDs will or will not be damaged by repairing.

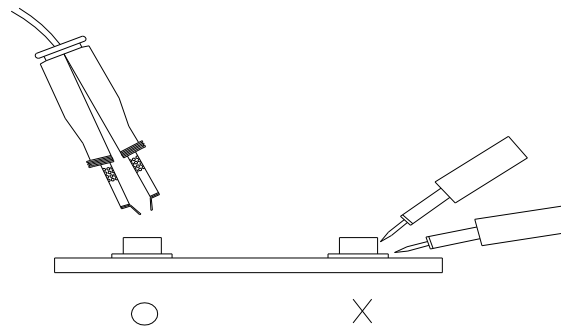

Label Form Specification

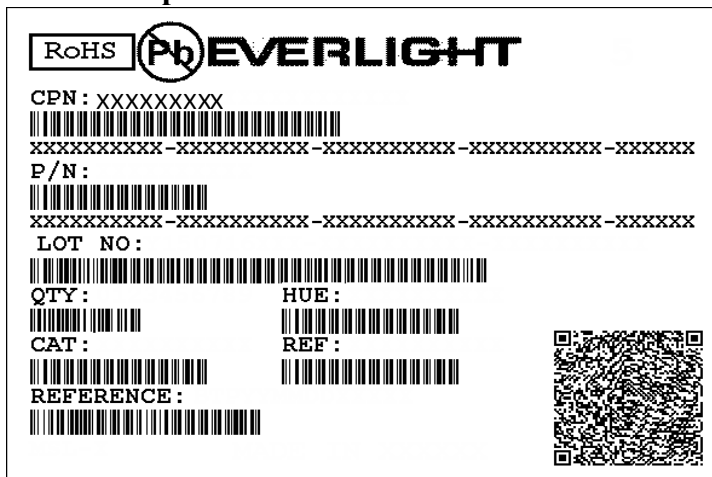

- CPN: Customer's Production Number
- P/N : Production Number
- QTY: Packing Quantity
- CAT: Ranks
- HUE: Peak Wavelength
- REF: Reference
- LOT No: Lot Number
- MADE IN TAIWAN: Production Place

Notes

1. Above specification may be changed without notice. EVERLIGHT will reserve authority on material change for above specification.
2. When using this product, please observe the absolute maximum ratings and the instructions for using outlined in these specification sheets. EVERLIGHT assumes no responsibility for any damage resulting from use of the product which does not comply with the absolute maximum ratings and the instructions included in these specification sheets.
3. These specification sheets include materials protected under copyright of EVERLIGHT corporation. Please don't reproduce or cause anyone to reproduce them without EVERLIGHT's consent.



## X-ON Electronics

Largest Supplier of Electrical and Electronic Components

*Click to view similar products for [Optical Switches, Reflective, Photo IC Output](#) category:*

*Click to view products by [Everlight](#) manufacturer:*

Other Similar products are found below :

[GP2A240LCS0F](#) [ITR1502SR40A/TR8](#) [ITR1204SR10A/TR\(BY\)](#) [AEDR-8300-1W1](#) [AEDR-8501-102](#) [AEDR-83001K2](#) [AEDR-83001P2](#)  
[AEDR-8300-1Q2](#) [C3012-TW-B-V](#) [C3012-TW-R-V](#) [GP2A230LRSF](#) [C128973](#) [K6-1212A-04](#) [K6-6271D-02](#) [K6-8859D-04](#) [EE-SG3M](#) [EE-](#)  
[SA801R](#) [1M](#) [EE-SPY801](#) [EE-SPY802](#) [EE-SY1201](#) [EE-SY310](#) [EE-SY410](#) [GP2A200LCS0F](#) [SR-0609-07](#) [TLLAG-72APG-R1KH1-V-A](#)  
[OPB715Z](#) [OPB716Z](#) [OPB718Z](#) [OPB720A-06Z](#) [OPB720A-30VZ](#) [OPB720B-06Z](#) [OPB720B-12Z](#) [OPB760N](#) [OPB770TZ](#) [OPB771TZ](#)  
[OPB773TZ](#)