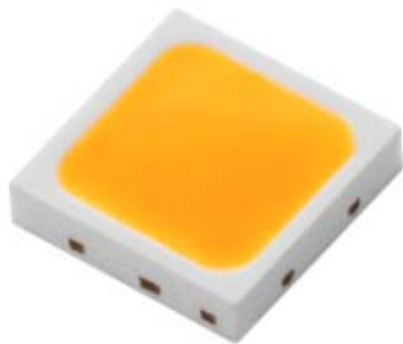

XI3030EU-NAYAYBF6F92734Z35-H41D-AM(MAG)

**Features**

- EMC package.
- Top view LED
- Moisture Sensitivity Level: 2A
- Wide viewing angle 115°
- High luminous intensity output
- Qualification according to AEC-Q101 rev C.
- Automotive reflow profile (IR reflow or wave soldering)
- Pb-free
- RoHS compliant
- ESD protection
- Compliance with EU REACH.

Description

The Everlight XI3030-AM series package has high efficacy, high power consumption, wide viewing angle and a compact form factor. These features make this package an ideal LED for all automobile lighting applications.

Applications

- Tail light
- Turning indicator light

Table of Contents

Product Nomenclature.....	3
XI3030 Soldering Temperature Location on sample Board	4
Absolute Maximum Ratings	5
PN of the XI3030-AM series: Amber LED	6
Product Binning:Luminous Flux Bins	7
Amber Bin Structure	8
Forward Voltage Bins.....	9
Mechanical Dimension	10
Wavelength Characteristics	11
Typical Diagram Characteristics of Radiation.....	14
Emitter Tape Packaging.....	15
Emitter Reel Packaging	16
Precautions for Use	17
Storage Conditions	18
Revision History.....	19

EVERLIGHT

Product Nomenclature

The product name is designated as below:

XI3030AB – CDEFGHIJ – KLMN – AM

Designation:

XI3030 = family name.

A = internal code

B = coating layer^[1]

C = color^[2]

DE = color bin or CCT bin

FG = min./max. luminous flux (lm) or radiation power (mW) performance

HI = min./max. forward voltage

J = operation current^[3]

KLMN = internal code

AM = application

1. Table of coating layer:

Symbol	Description
U	Gold
G	Silver

2. Table of color:

Symbol	Description
NP	White, CRI<80
KP	White, CRI>80
NA	PC-Amber
UR	Red

3. Table of operation current:

Symbol	Description
Z35	350mA

XI3030 Soldering Temperature Location on Sample Board

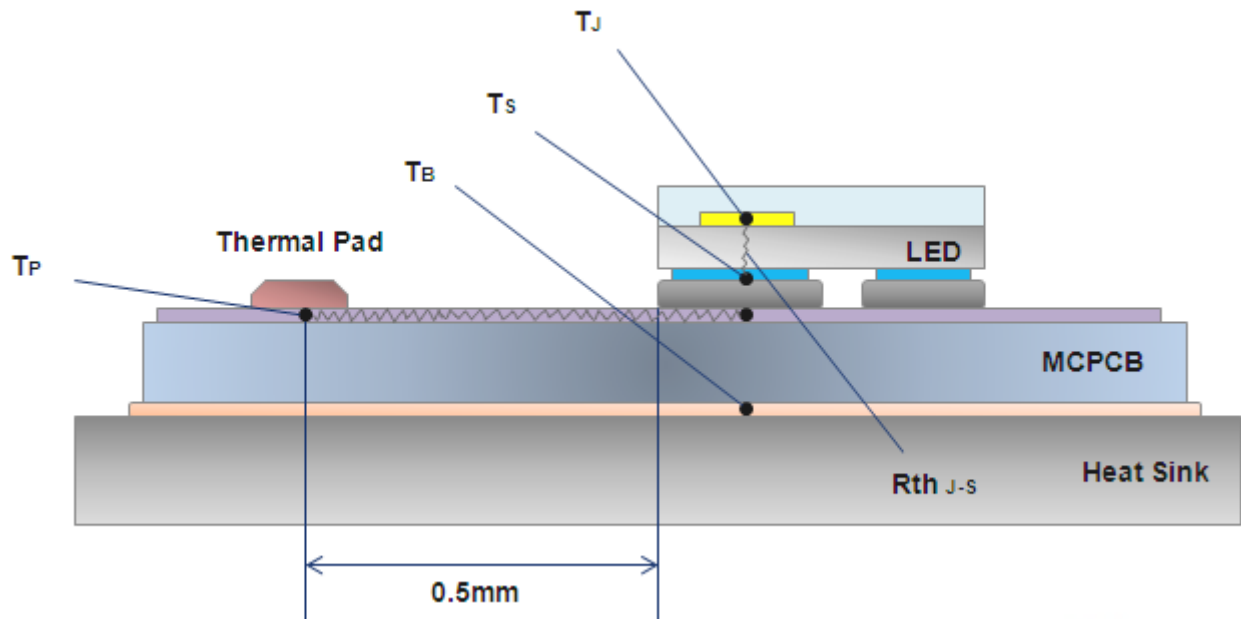

T_J = Temperature of Junction

T_S = Temperature of Solder Pad

T_B = Temperature of MCPCB

T_P = Temperature of Thermal Pad

$R_{th\ J-S}$ = Thermal Resistance from Junction to Solder Pad

Absolute Maximum Ratings

Parameter	Symbol	Ratings	Unit
Reverse Voltage	V_R	Not designed for reverse operation	V
Max. DC Forward Current (mA)	I_F	700	mA
Max. Peak Pulse Current (mA)	I_{Pulse}	1000 _[1]	mA
Junction Temperature	T_J	130	°C
Thermal Resistance (Junction to Soldering)	R_{th}	11	°C/W
Operating Temperature	T_{opr}	-40 ~ +100	°C
Storage Temperature	T_{stg}	-40 ~ +125	°C
ESD Sensitivity	ESD_{HBM}	8000	V
Max. Soldering Temperature	T_{Sol}	260	°C
Max. Allowable Reflow Cycles	N/A	3	cycles

Notes:

1. Duty cycle = 1/10@1KHZ .

EVERLIGHT

PN of the XI3030-AM series: LED

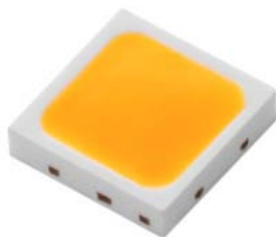

Order Code of XI3030	Minimum Luminous Flux (lm)	Typical Luminous Flux (lm)	Color Bin	Forward Voltage (V)	Current (mA)	Typical Viewing Angle (degrees) $2\theta_{1/2i}$
XI3030EU-NAYAYBF6F92734Z35-H41D-AM	60	68	YA-YB	2.7-3.4	350	115

Notes:

1. Luminous flux measurement tolerance: $\pm 8\%$.
2. The data of luminous flux measured at thermal pad= 25°C
3. Typical luminous flux or light output performance is operated within the condition guided by this datasheet.

EVERLIGHT

Product Binning Luminous Flux Bins

Group	Bin	Minimum Photometric Flux (lm)	Maximum Photometric Flux (lm)
E	1	4	5
	2	5	6
	3	6	8
	4	8	10
	5	10	13
	6	13	17
	7	17	20
	8	20	23
	9	23	27
Group	Bin	Minimum Photometric Flux (lm)	Maximum Photometric Flux (lm)
F	1	27	33
	2	33	39
	3	39	45
	4	45	52
	5	52	60
	6	60	70
	7	70	80
	8	80	90
	9	90	100

Group	Bin	Minimum Photometric Flux (lm)	Maximum Photometric Flux (lm)
J	1	100	110
	2	110	120
	3	120	130
	4	130	140
	5	140	150
	6	150	160
	7	160	180
	8	180	200
	9	200	225
Group	Bin	Minimum Photometric Flux (lm)	Maximum Photometric Flux (lm)
K	1	225	250
	2	250	275
	3	275	300
	4	300	325
	5	325	350
	6	350	375
	7	375	400
	8	400	425
	9	425	450

Notes:

- Luminous flux measurement tolerance: $\pm 8\%$.

Amber Bin Structure

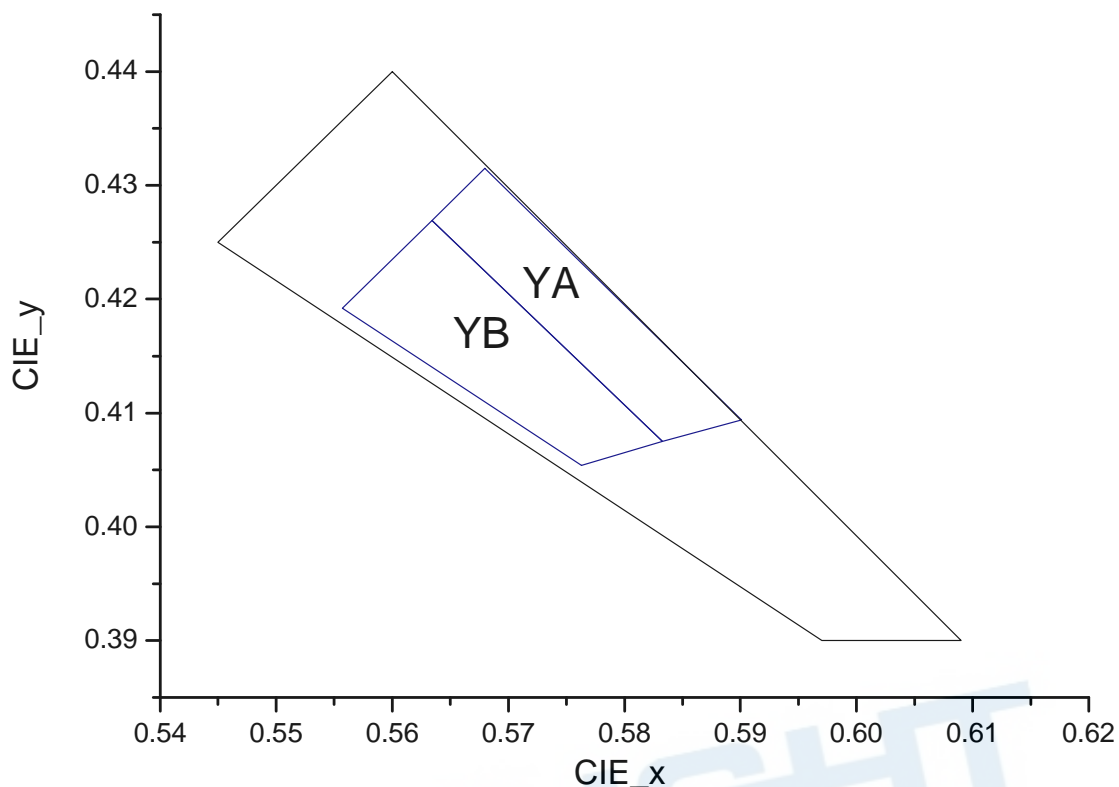

Amber Bin Coordinates

Amber

Bin	CIE X	CIE Y
YA	0.5680	0.4315
	0.5634	0.4269
	0.5833	0.4075
	0.5901	0.4094

Bin	CIE X	CIE Y
YB	0.5763	0.4054
	0.5833	0.4075
	0.5634	0.4269
	0.5557	0.4192

Notes:

Color coordinates measurement allowance: ±0.01.

Forward Voltage Bins

Group	Bin	Minimum Forward Voltage (V)	Maximum Forward Voltage (V)
2734	A	2.7	3.0
	B	3.0	3.3
	C	3.3	3.4

Notes:

1. Forward voltage measurement tolerance: $\pm 0.1V$.
2. Forward voltage bins are defined at $I_f=350mA$ operation.

EVERLIGHT

Mechanical Dimension

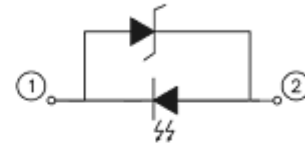
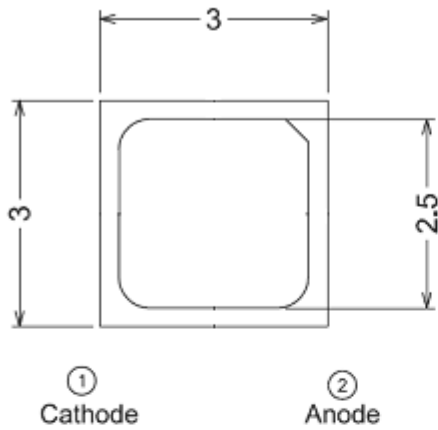

Polarity

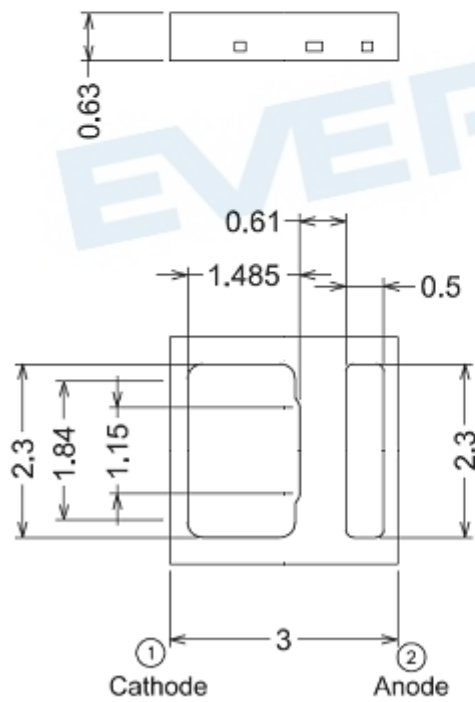

Bot. view

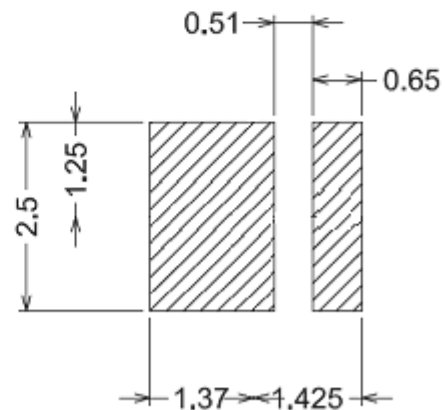

Soldering patterns

Notes:

1. Dimensions are in millimeters.
2. Tolerances unless mentioned are $\pm 0.2\text{mm}$.
3. The thermal pad is electrically unity from the Anode and contact pads.
4. Do not handle the device by the lens. Incorrect force applied to the lens may lead to the failure of devices.

Wavelength Characteristics

Relative Spectral Distribution

@ Solder Pad Temperature = 25°C

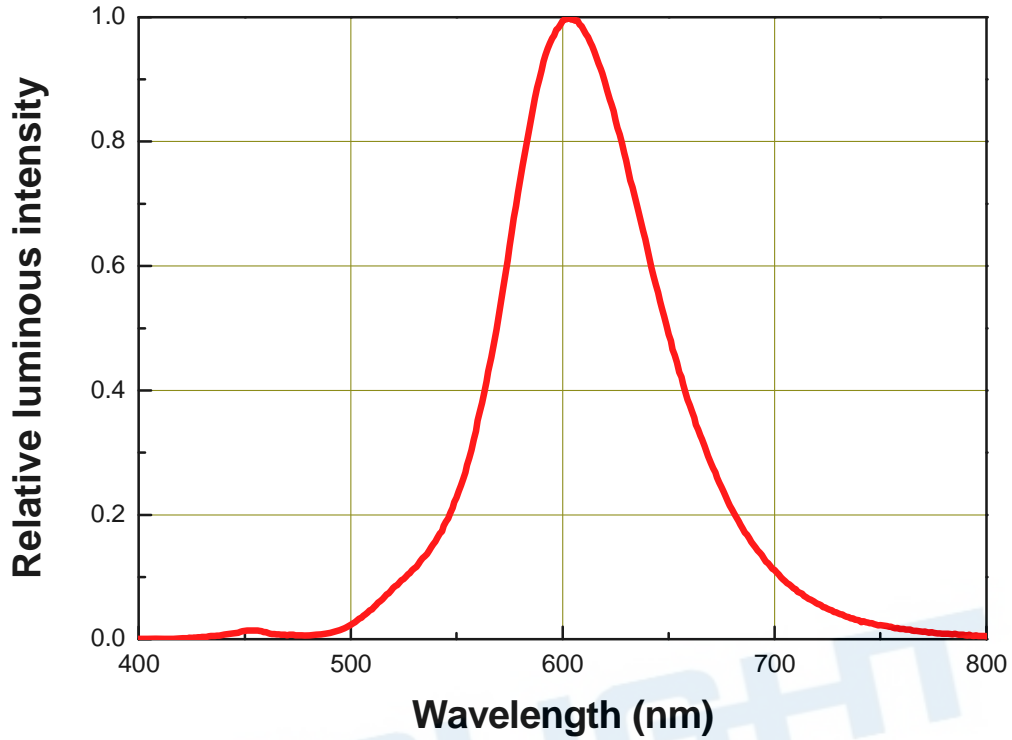

Forward Current Derating Curve

@ Junction Temperature <130°C

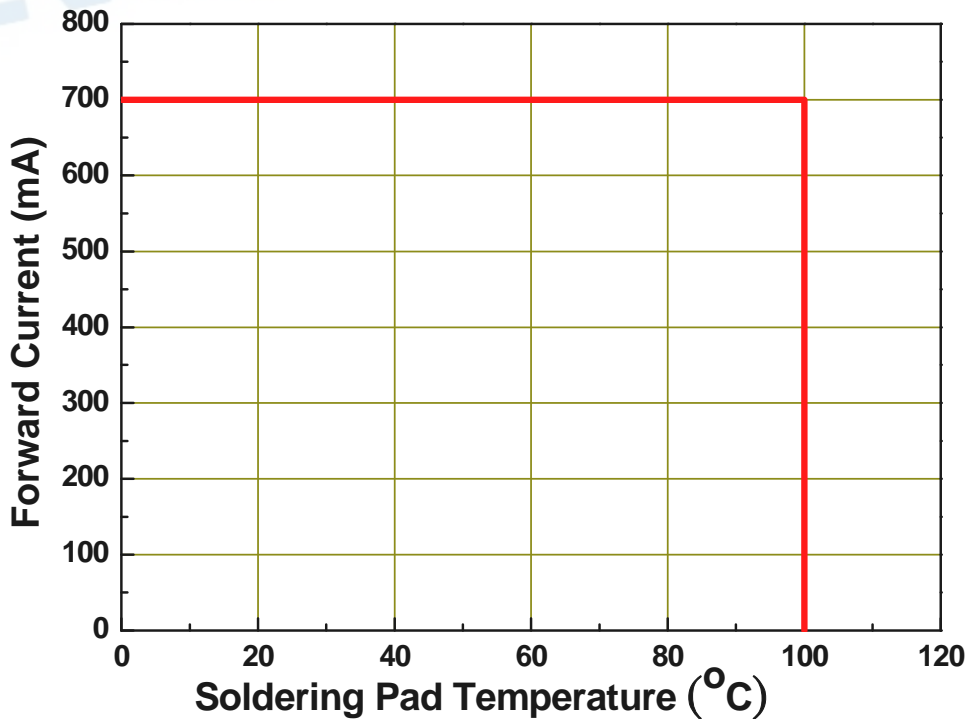

Forward Voltage vs. Forward Current
@ Solder Pad Temperature = 25°C

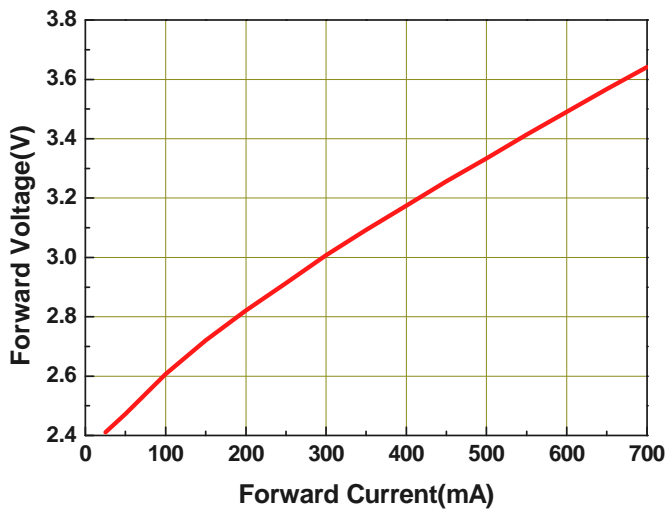

Luminous vs. Forward Current
@ Solder Pad Temperature = 25°C

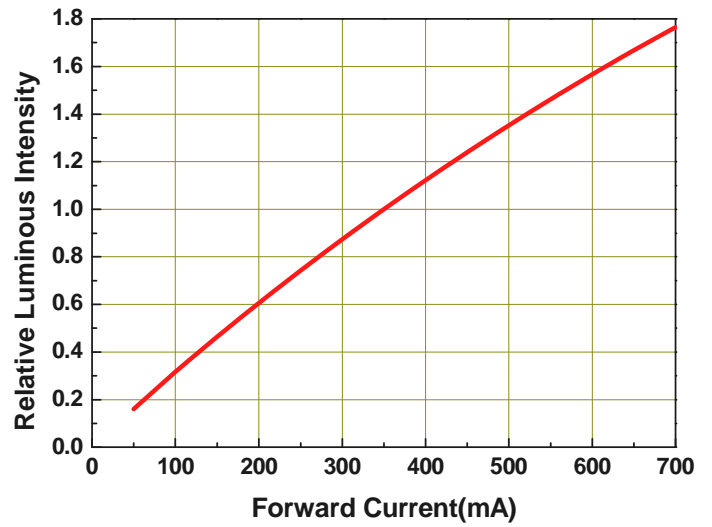

Chromaticity Coordinates Shift vs. Forward Current

@ Solder Pad Temperature = 25°C

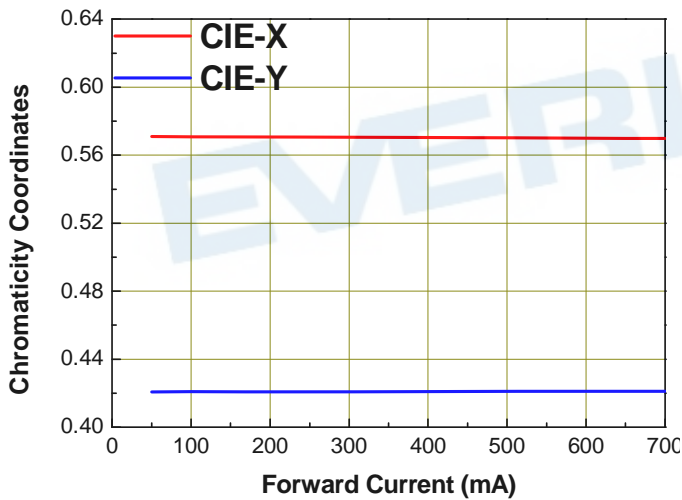

Relative Forward Voltage
 @Forward Current = 350mA/700mA

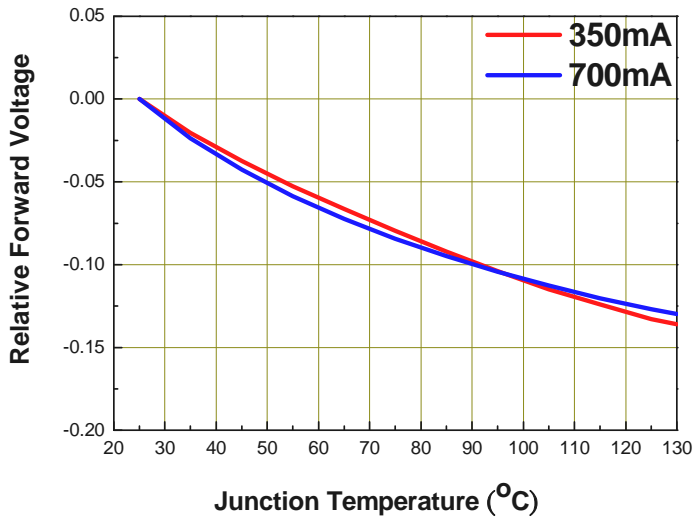

Relative Luminous Flux
 @Forward Current = 350mA/700mA

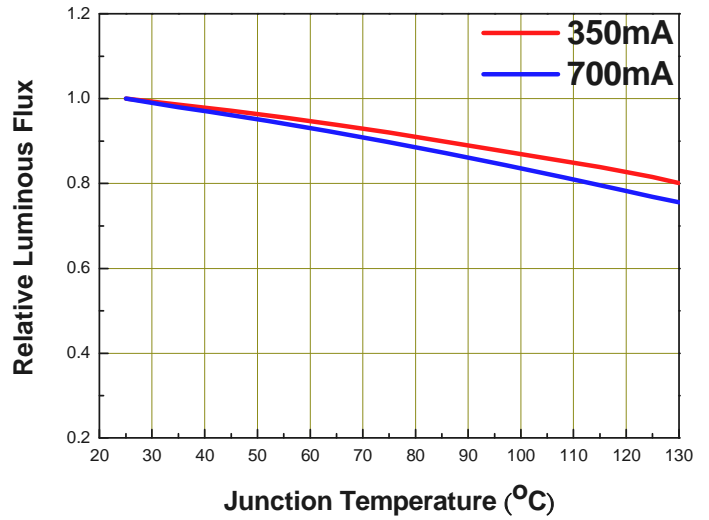

Chromaticity Coordinates Shift CIE-X
 @Forward Current = 350mA/700mA

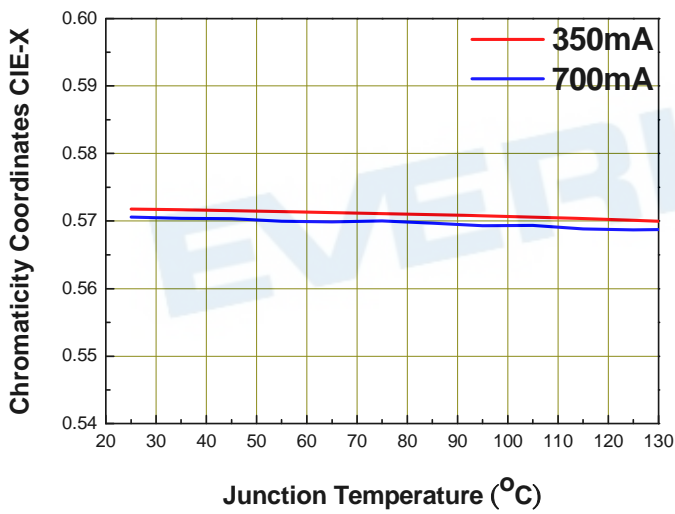

Chromaticity Coordinates Shift CIE-Y
 @Forward Current = 350mA/700mA

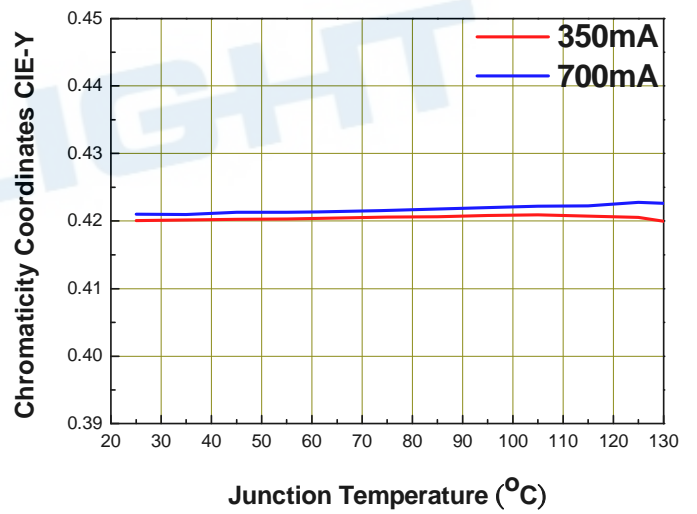

XI3030 series: Typical Diagram Characteristics of Radiation

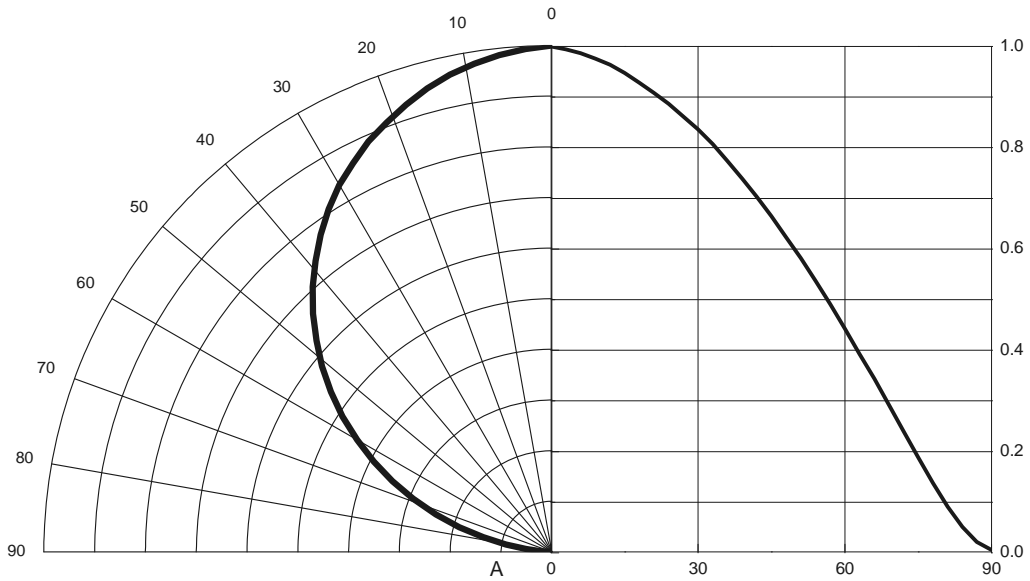

Notes:

1. $2\theta_{1/2}$ is the off axis angle from lamp centerline where the luminous intensity is 1/2 of the peak value.
2. View angle tolerance is $\pm 5^\circ$.

EVERLIGHT

Emitter Reel Packaging

Reel Dimensions

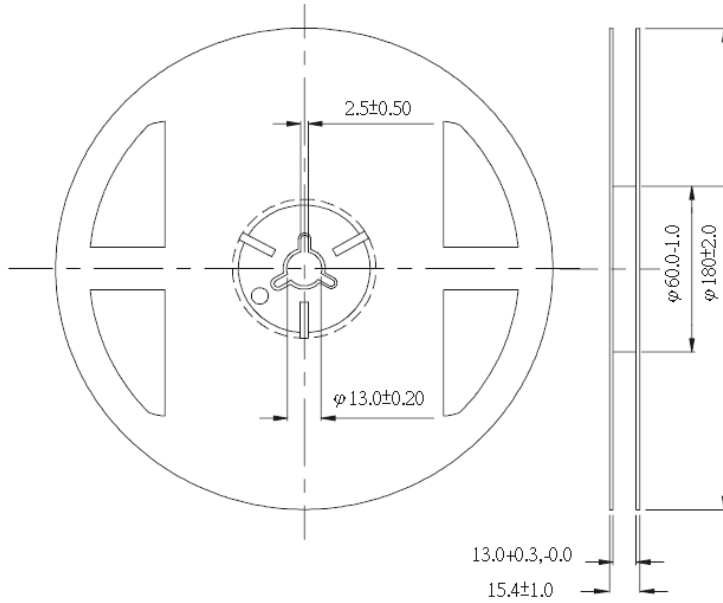

Notes:

1. Dimensions are in millimeters.
2. Tolerances unless mentioned are ± 0.1 mm.

Product Labeling

Label Explanation

CPN: Customer Specification (when required)

P/N : Everlight Production Number

QTY: Packing Quantity

CAT: Luminous Flux (Brightness) Bin

HUE: Color Bin

REF: Forward Voltage Bin

LOT No: Lot Number

MADE IN TAIWAN: Production Place

RoHS EVERLIGHT 5

CPN: XXXXXXXXXXXXXXXXXXXXXXXX
 XXXXXXXXXXX-XXXXXXXXXXXX-XXXXXXXXXXXX-XXXXXXXXXXXX-XXXXXX
 P/N: XXXXXXXXXXXXXXX
 XXXXXXXXXXX-XXXXXXXXXXXX-XXXXXXXXXXXX-XXXXXXXXXXXX-XXXXXX
 LOT NO: Y150716XXX-XXXXXXXXXXXX-XXXXXXXXXXXX
 QTY: 0123456789 HUE: XXXXXXXXXXX
 CAT: XXXXXXXXXXX REF: XXXXXXXXXXX
 REFERENCE: BTPYMMDDXXXXX
 MADE IN XXXXXX



Precautions for Use

1. Over-current-proof
Customer must apply resistors for protection; otherwise slight voltage shift will cause big current change (Burn out will happen).
2. Assemblies
Do not stack assemblies containing Everlight XI3030 LEDs to prevent damage to the optical surface of LEDs. Forces applied to the optical surface may result in the surface being damaged.
3. Soldering Condition
3.1 Pb-free solder temperature profile

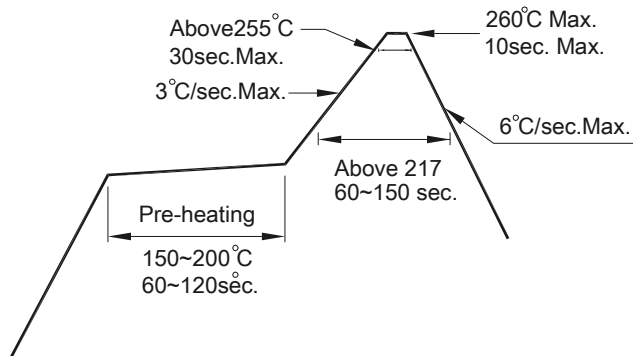

- 3.2 Reflow soldering should not be done more than two times.
- 3.3 When soldering, do not put stress on the LEDs during heating.
- 3.4 After soldering, do not warp the circuit board.
4. Soldering Iron
Each terminal is to go to the tip of soldering iron temperature less than 350°C for 3 seconds within once in less than the soldering iron capacity 25W. Leave two seconds and more intervals, and do soldering of each terminal. Be careful because the damage of the product is often started at the time of the hand solder.
5. Repairing
Repair should not be done after the LEDs have been soldered. When repairing is unavoidable, a double-head soldering iron should be used (as below figure). It should be confirmed beforehand whether the characteristics of the LEDs will or will not be damaged by repairing.

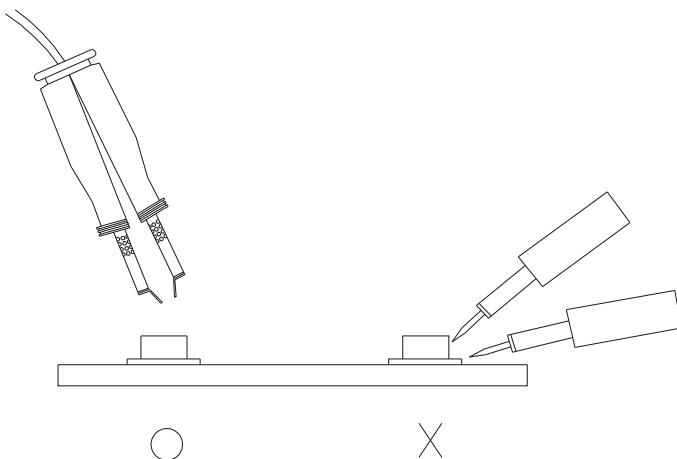

Storage Conditions

- Before the package is opened. The LEDs should be stored at 30°C or less and 90%RH or less after being shipped from Everlight and the storage life limits are 18 months. The LEDs can be stored up to 3 years If in a sealed container with a nitrogen atmosphere and moisture absorbent material.
- After opening the package: The LED's floor life is 1 year under 30°C or less and 60%RH or less. The LED should be soldered with 168hrs (7days) after opening the package. If unused LEDs remain, it should be stored in moisture proof packages.
- If the moisture absorbent material (silica gel) has faded away or the LEDs have exceeded the storage time, baking treatment should be performed using the following conditions. Baking treatment: 60±5°C for 24 hours.

EVERLIGHT

Revision History

Current version: 04.22.2016
Issue No: DHE-0003104
Version: 2
Created by: Betty Hong

Rev	Subjects (major change in previous version)	Date of change
1	Mass Production	2016/07/14
2	Package method modify	2017/11/22

EVERLIGHT

X-ON Electronics

Largest Supplier of Electrical and Electronic Components

Click to view similar products for [Standard LEDs - SMD category](#):

Click to view products by [Everlight manufacturer](#):

Other Similar products are found below :

[LTST-C190KYKT](#) [LTST-C19GD2WT](#) [LTST-N683GBEW](#) [LTW-170ZDC](#) [LTW-M140SZS40](#) [LTW-M140ZVS](#) [598-8110-100F](#) [91-21SUBCS400-A6TR7](#) [AAAF5060QBFSEEZGS](#) [APT1608QGW](#) [99-213/R6C-AR2T1B/2C](#) [SML-LX0606SISUGC/A](#) [SML-LXR851SIUPGUBC](#) [LT1ED53A](#) [AM27ZGC03](#) [APFA3010SURKCGKQBDC](#) [APHK1608VGCA](#) [APT2012QGW](#) [LTST-008BGEW](#) [LTW-010DCG](#) [LTW-020ZDCG](#) [LTW-21TS5](#) [LTW-220DS5](#) [LO T67F-V1AB-24-1](#) [598-8330-117F](#) [CMDA20AYAA7D1S](#) [95-21SURCS530-A3TR10](#) [HSMQ-C177](#) [598-8040-100F](#) [598-8070-100F](#) [598-8140-100F](#) [598-8610-200F](#) [SML-LXL1209SYC/ATR](#) [CMD91-21VRC/TR7](#) [SML-512PWT86A](#) [SMF-2432GYC-TR](#) [EASV3015RGYA0](#) [LTST-C190KFKT-5A](#) [LTST-C194TBKT-5A](#) [CLX6E-FKC-CH1M1D1BB7C3D3](#) [SML-LXL0805USBC-TR](#) [SML-LX2835SYSUGCTR](#) [LTW-M670ZVS-M5](#) [APA2106ZGC/G](#) [CLMXB-FKA-CbcfghjnpACBB79463](#) [VFA1101W-5AY3B2-TR](#) [LCB P473-P2R2-3J7L-1-Z](#) [HSMR-C197](#) [LW A67C-S2U1-FK0KM0](#) [LW A673-P1S1-FK0PM0](#)